

[54] TRUCK BED TIE-DOWN HOLDER

[76] Inventor: Michael N. Wensien, 2627 N. Spring Dr., Spring, Tex. 77373

[\*\*] Term: 14 Years

[21] Appl. No.: 147,687

[22] Filed: Jan. 25, 1988

[52] U.S. Cl. .... D8/367; D8/306

[58] Field of Search ..... D8/356, 367, 306, 401, D8/DIG. 1, DIG. 2, DIG. 6; 248/145.6, 315

[56] References Cited

U.S. PATENT DOCUMENTS

- D. 161,360 12/1950 Mitchell ..... D3/76
- D. 183,739 10/1958 Gomersall ..... D8/DIG. 1
- D. 214,778 7/1964 Solie ..... D8/306
- D. 216,076 11/1969 Marks ..... D8/306
- D. 220,747 5/1971 Readrick ..... D8/306
- D. 225,721 1/1973 Doyle ..... D8/306

- D. 236,323 8/1975 Johnsen et al. .... D8/367
- D. 236,795 9/1975 Paulich ..... D8/401
- D. 258,345 2/1981 Paul ..... D8/306
- 2,578,646 12/1951 Ruben ..... 248/145.6
- 4,691,473 8/1987 Ragen ..... 248/315

Primary Examiner—Horace B. Fay, Jr.  
Attorney, Agent, or Firm—Jerry T. Kearns

[57] CLAIM

The ornamental design for truck bed tie-down holder, as shown and described.

DESCRIPTION

FIGS. 1 and 2 are respectively front and rear elevational views of a truck bed tie-down holder showing my new design; FIGS. 3 and 4 are respectively left and right side elevational views thereof; and FIGS. 5 and 6 are respectively top and bottom plan views thereof.

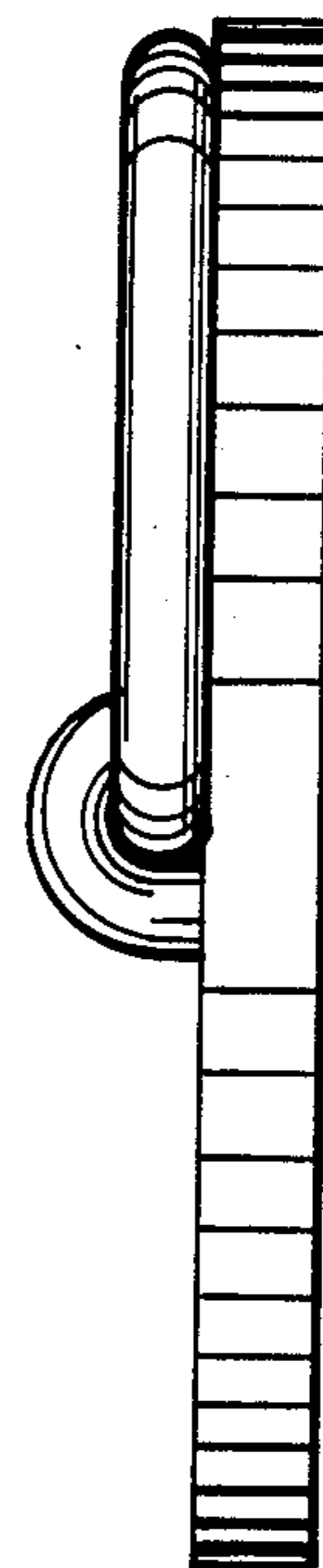
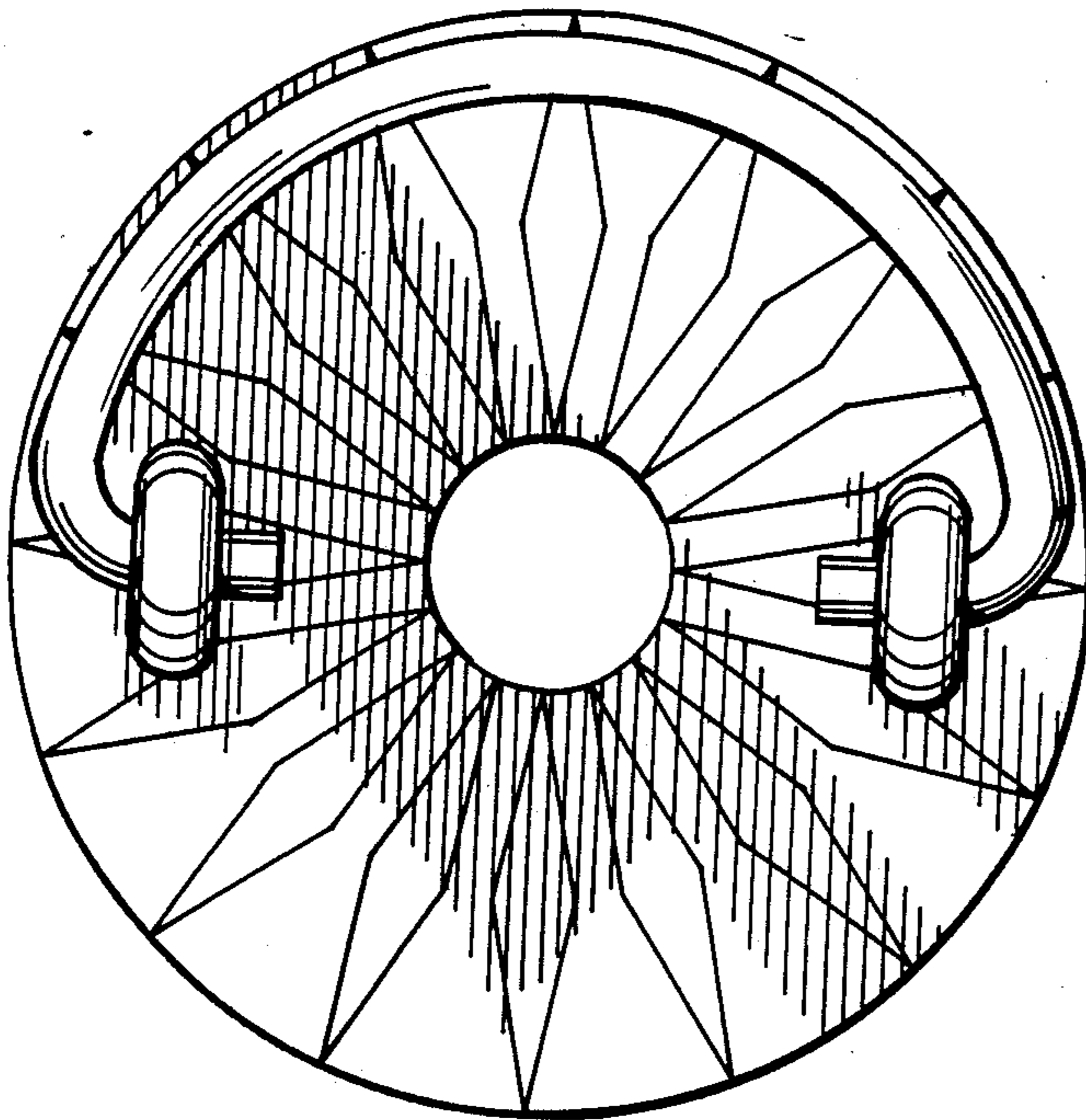

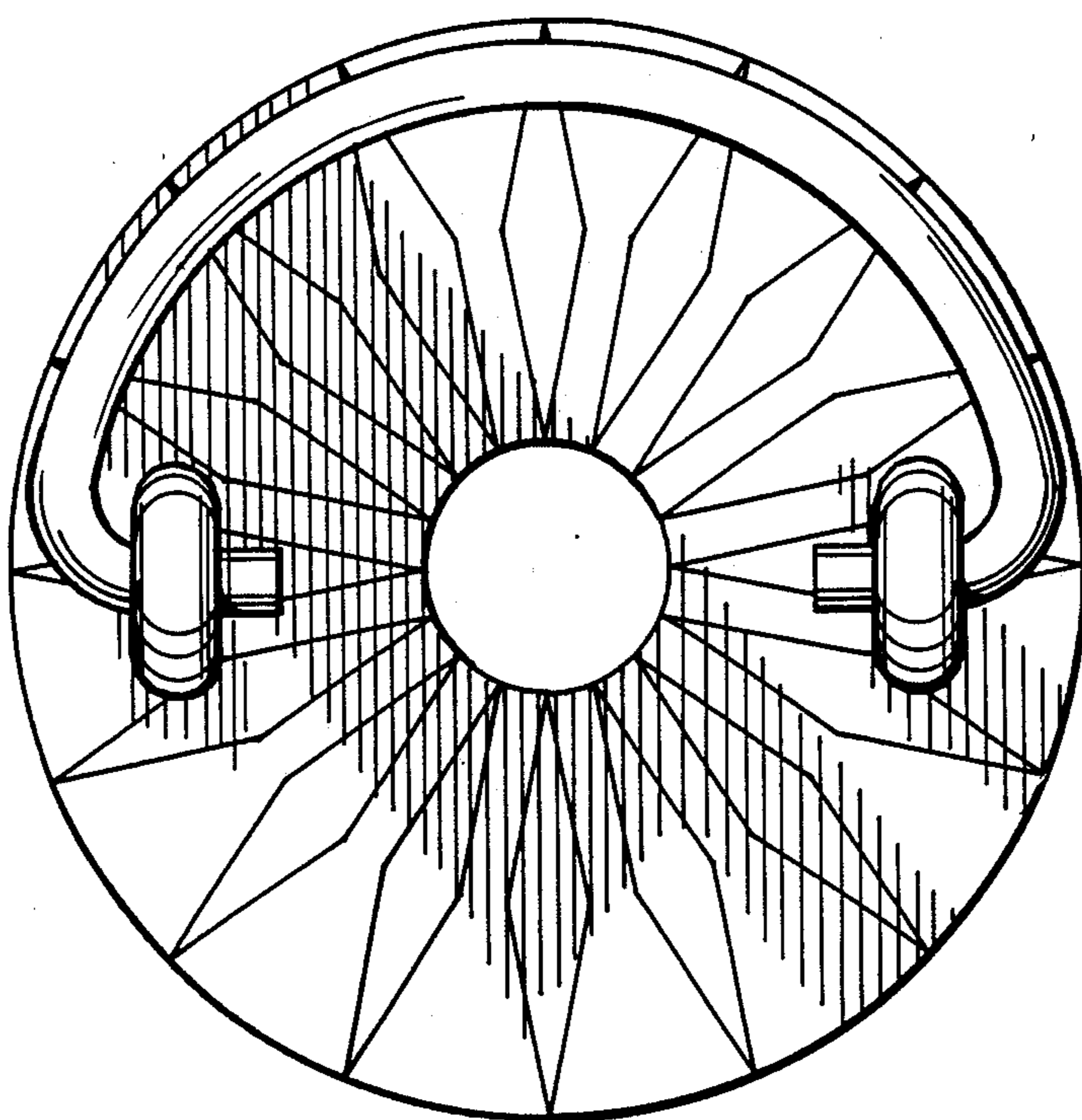

Fig. 1

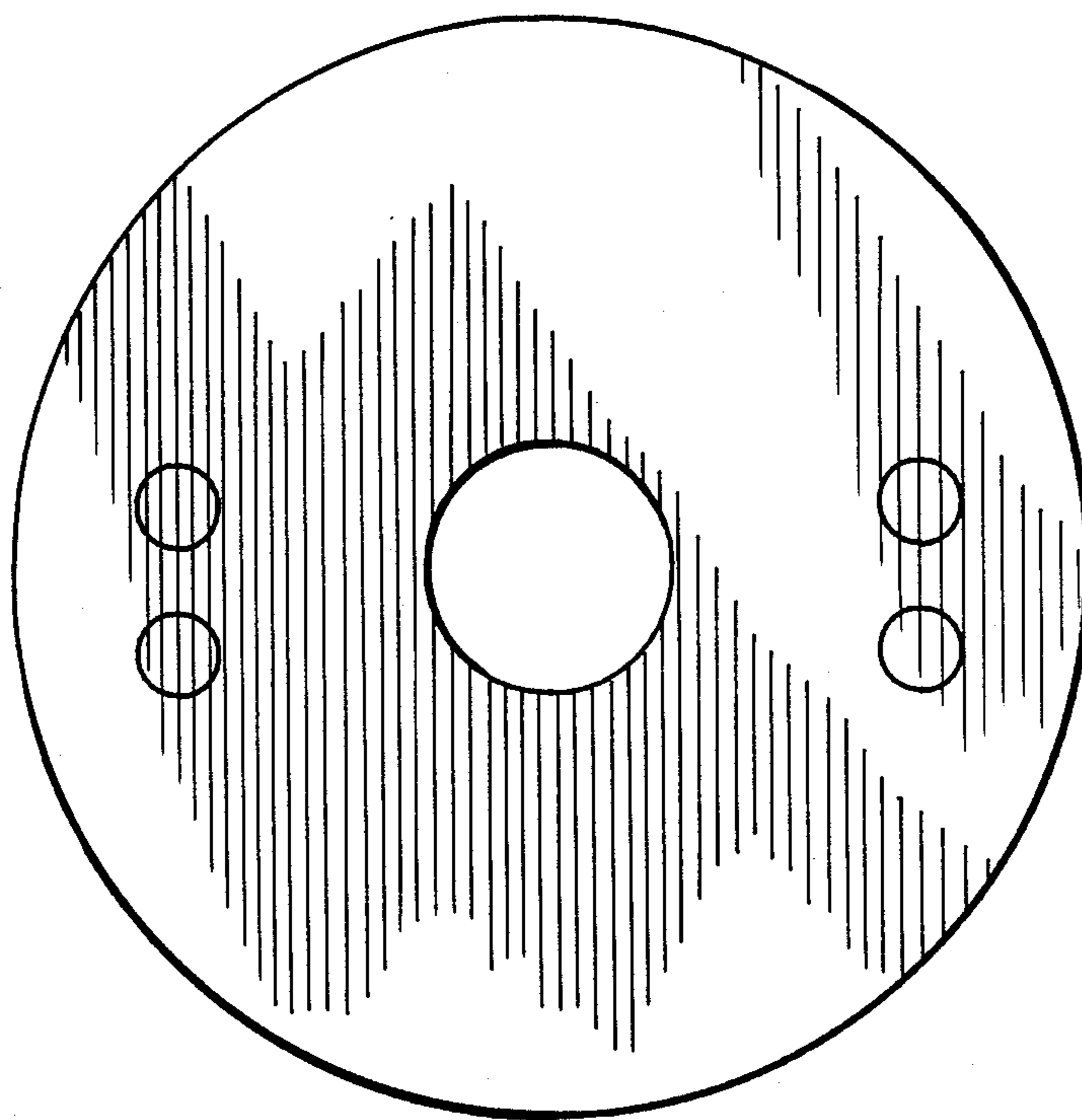

Fig. 2

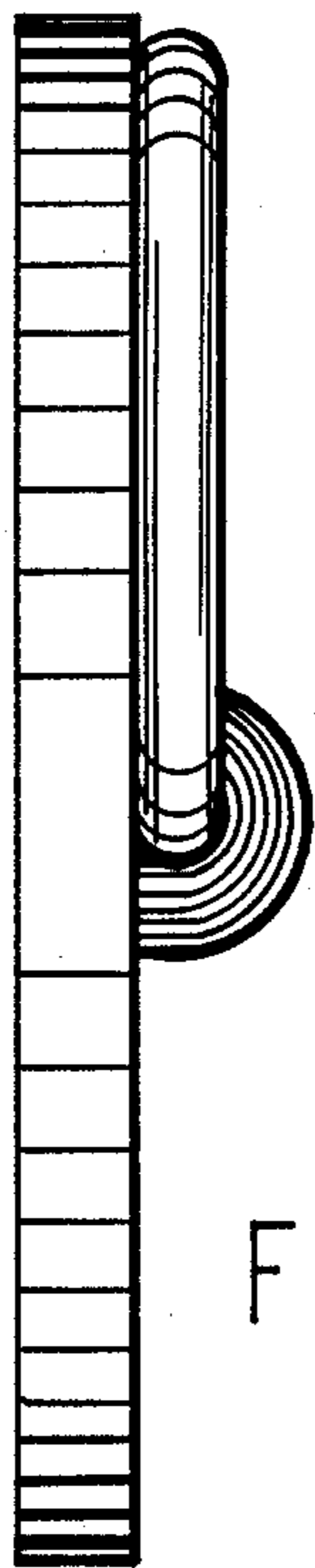

Fig. 3

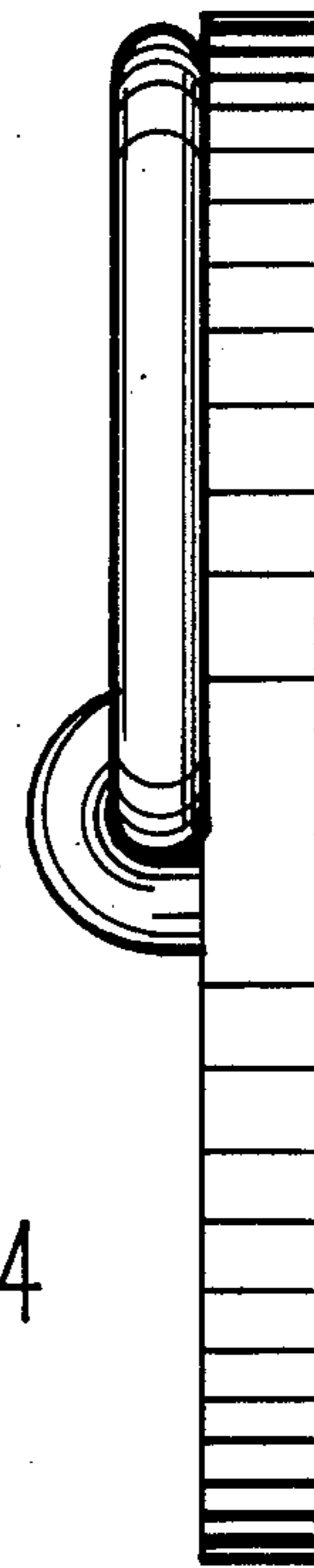

Fig. 4

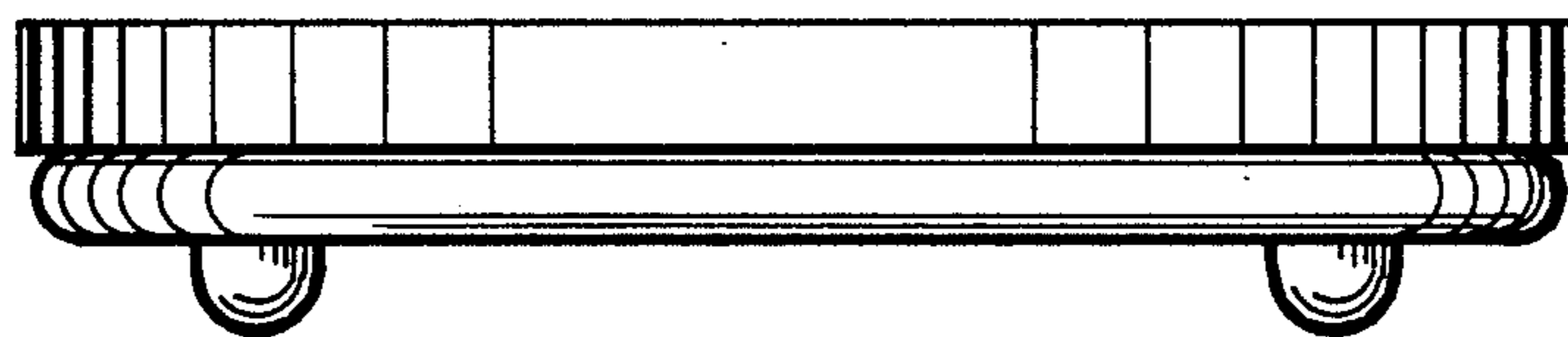

Fig. 5

Fig. 6

