

[54] AIRPLANE

[75] Inventor: John J. Andrews, San Diego, Calif.

[73] Assignee: The Testor Corporation, San Diego, Calif.

[\*\*] Term: 14 Years

[21] Appl. No.: 80,692

[22] Filed: Aug. 3, 1987

[52] U.S. Cl. .... D12/331; D12/319

[58] Field of Search ..... D12/335, 319, 342, 331, D12/332; 244/15, 45 A, 53 R, 52, 36

[56] References Cited

U.S. PATENT DOCUMENTS

D. 291,554	8/1987	Enav et al. ....	D12/332
D. 294,478	3/1988	Asdurian et al. ....	D12/319
4,343,446	8/1982	Langley .....	D12/335

OTHER PUBLICATIONS

Flight Int'l, May 23, 1981, "LLWDS" (top).  
Flight Int'l, Jun. 11, 1983, "ATF" of Rockwell.

Primary Examiner—Wallace R. Burke  
Assistant Examiner—Kay H. Chin  
Attorney, Agent, or Firm—Fay, Sharpe, Beall, Fagan,  
Minnich & McKee

[57] CLAIM

The ornamental design for an airplane, as shown and described.

DESCRIPTION

FIG. 1 is a top perspective view of an airplane showing my new design;  
FIG. 2 is a top plan view thereof;  
FIG. 3 is a left side elevational view thereof, the right side elevational view being a mirror image of that shown;  
FIG. 4 is a bottom plan view thereof;  
FIG. 5 is a rear elevational view thereof; and  
FIG. 6 is a front elevational view thereof.

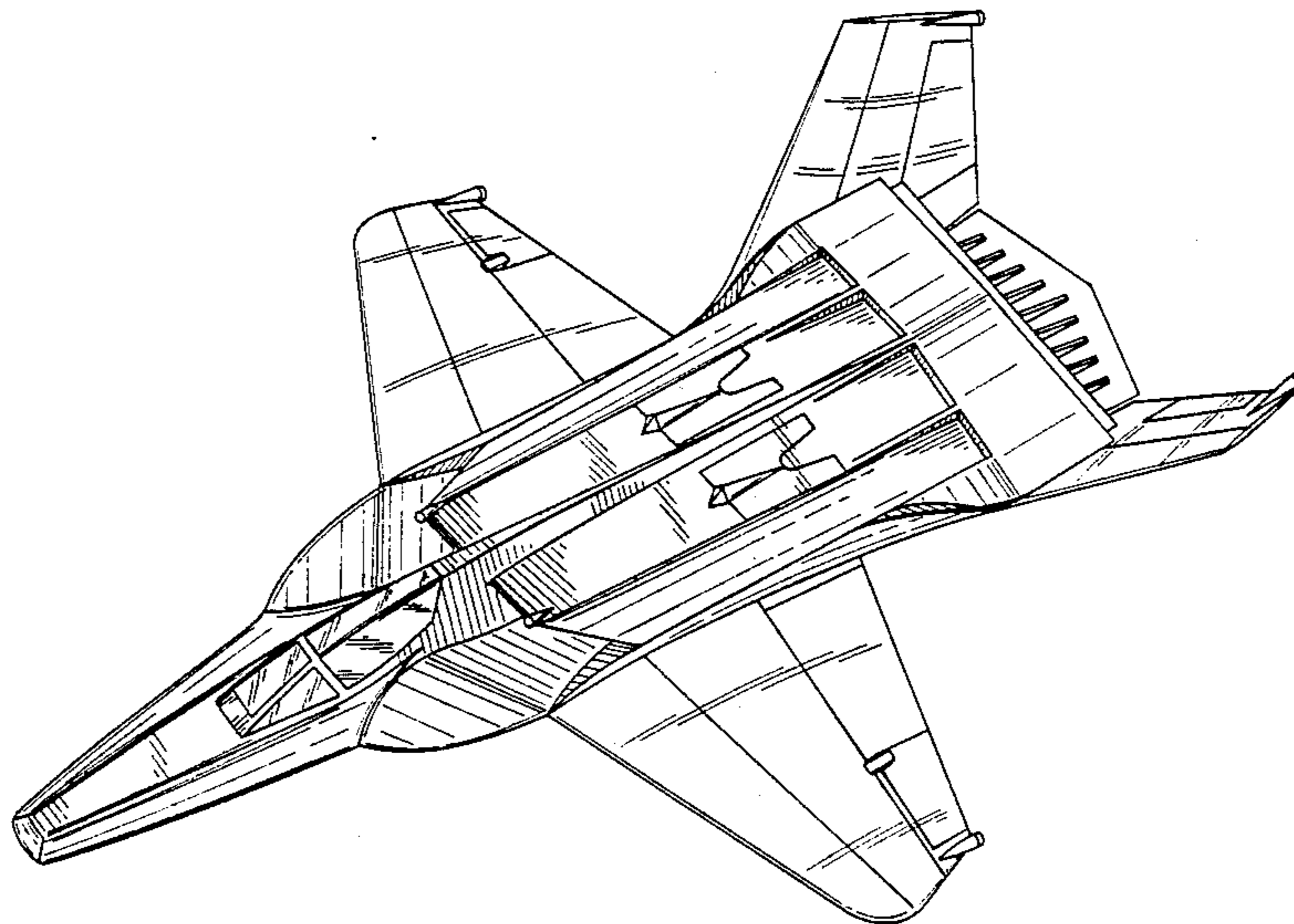

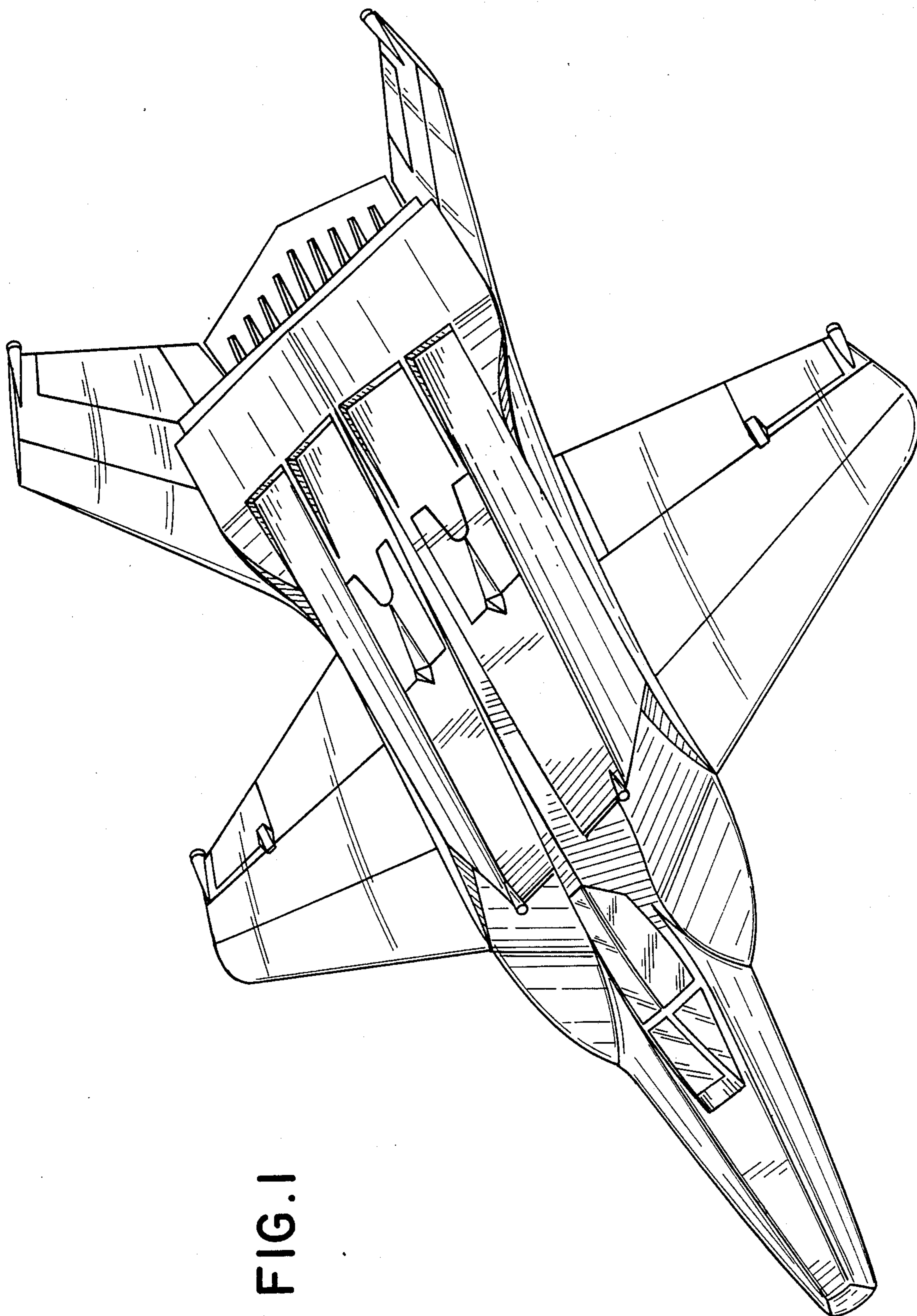

FIG. 1

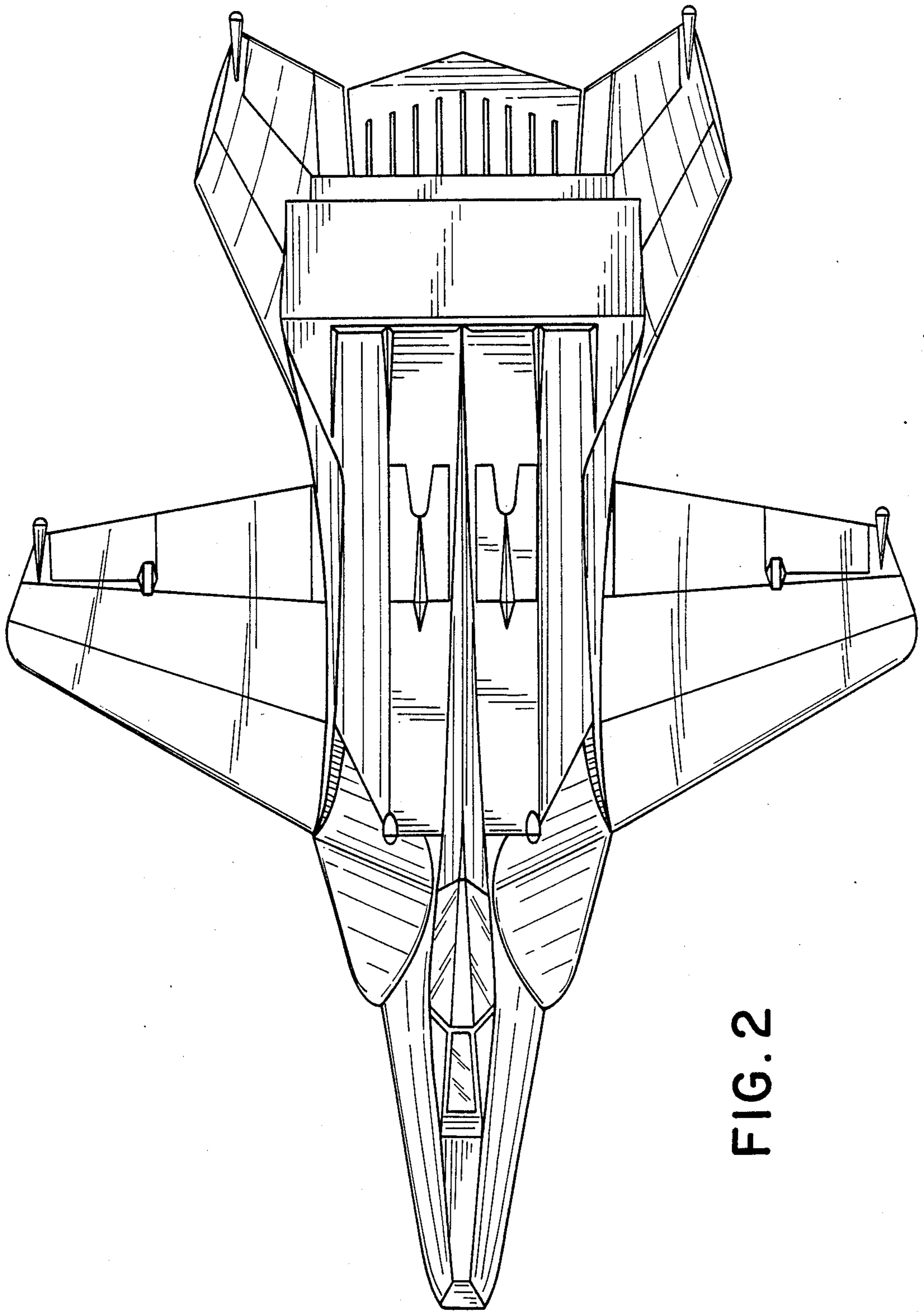

FIG. 2

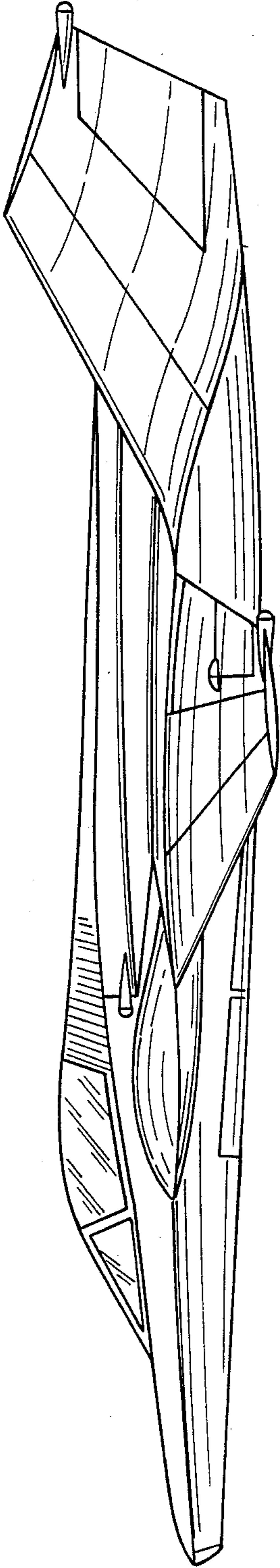

FIG. 3

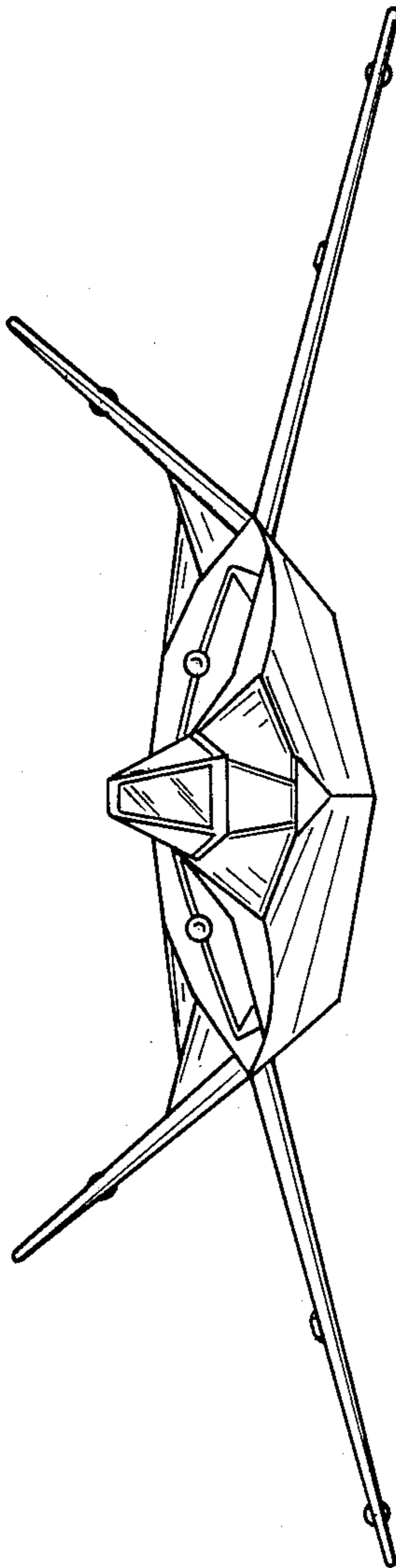

FIG. 6

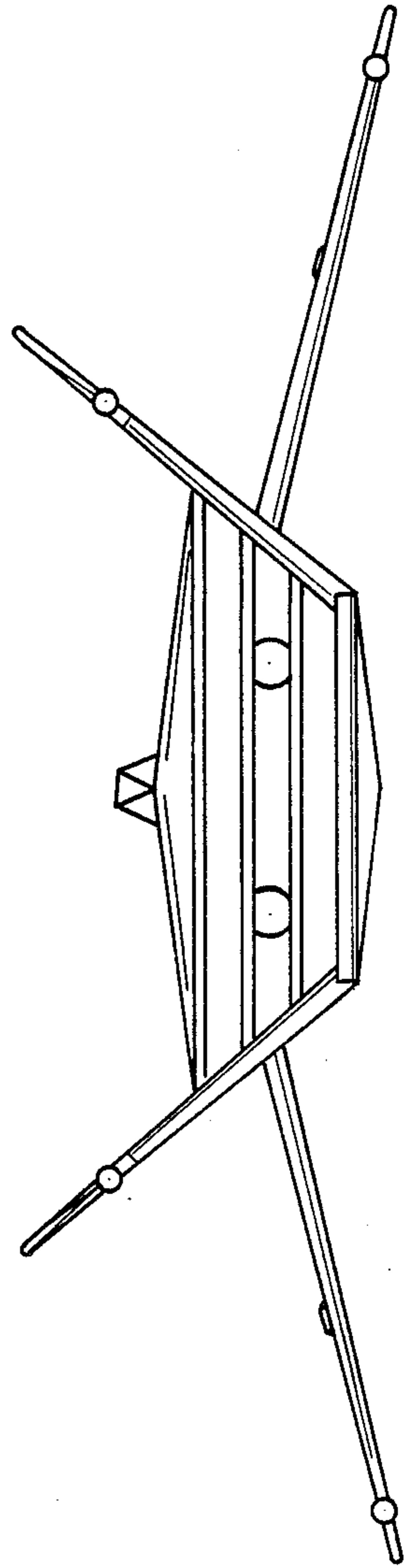

FIG. 5

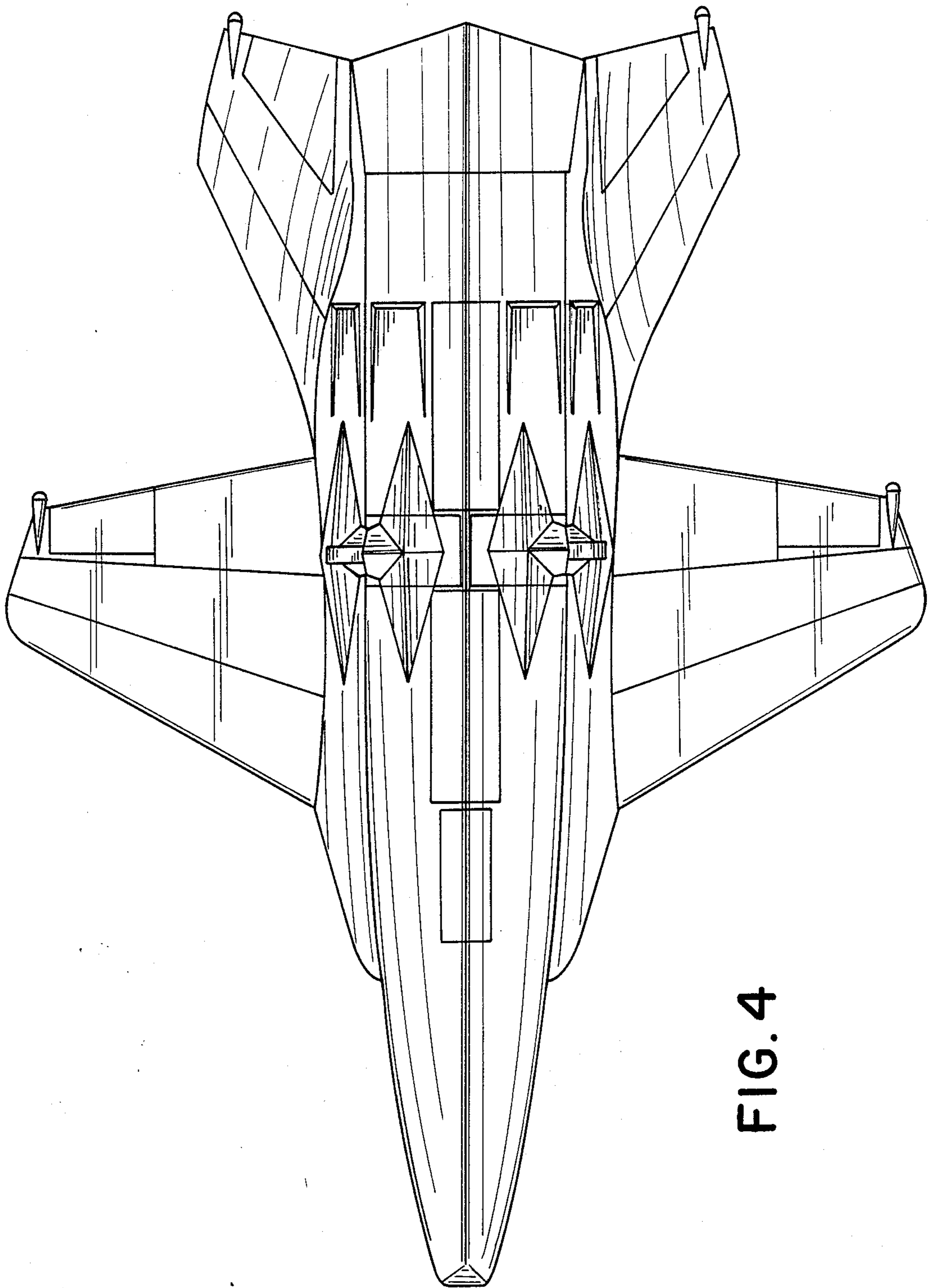

FIG. 4