

[54] VEHICLE LUGGAGE CARRIER

DESCRIPTION

[76] Inventor: John A. Bott, 931 Lakeshore Dr., Grosse Pointe Shores, Mich. 48236

[**] Term: 14 Years

[21] Appl. No.: 27,814

[22] Filed: Mar. 19, 1987

[52] U.S. Cl. D12/157

[58] Field of Search D12/157; 224/324, 326, 224/327, 328, 329, 330, 331

[56] References Cited

U.S. PATENT DOCUMENTS

D. 294,137	2/1988	Robson	D12/157
4,245,764	1/1981	Kowalski et al.	224/324
4,448,337	5/1984	Cronce	224/326
4,684,048	8/1987	Bott	224/324

Primary Examiner—James M. Gandy

Attorney, Agent, or Firm—Harness, Dickey & Pierce

[57] CLAIM

The ornamental design for a vehicle luggage carrier, as shown and described.

FIG. 1 is a perspective view of the vehicle luggage carrier showing my new design;
 FIG. 2 is a top plan view thereof;
 FIG. 3 is a side elevation view thereof looking in the direction of arrow III in FIG. 1;
 FIG. 4 is an interior side elevation view thereof looking in the direction of arrow IV in FIG. 1;
 FIG. 5 is a left end elevation view thereof looking in the direction of arrow V in FIG. 1;
 FIG. 6 is a right end elevation view thereof looking in the direction of arrow VI in FIG. 1;
 FIG. 7 is an enlarged fragmentary perspective view of the portion thereof shown within the circle VII in FIG. 1;
 FIG. 8 is a top plan view of FIG. 7 looking in the direction of arrow VIII therein;
 FIG. 9 is a side elevation view of FIG. 7 looking in the direction of arrow IX therein;
 FIG. 10 is a left end elevation view of FIG. 7 looking in the direction of arrow X therein;
 FIG. 11 is a right end elevation view of FIG. 7 looking in the direction of arrow XI therein; and
 FIG. 12 is an interior elevation view of FIG. 7 looking in the direction of arrow XII therein.

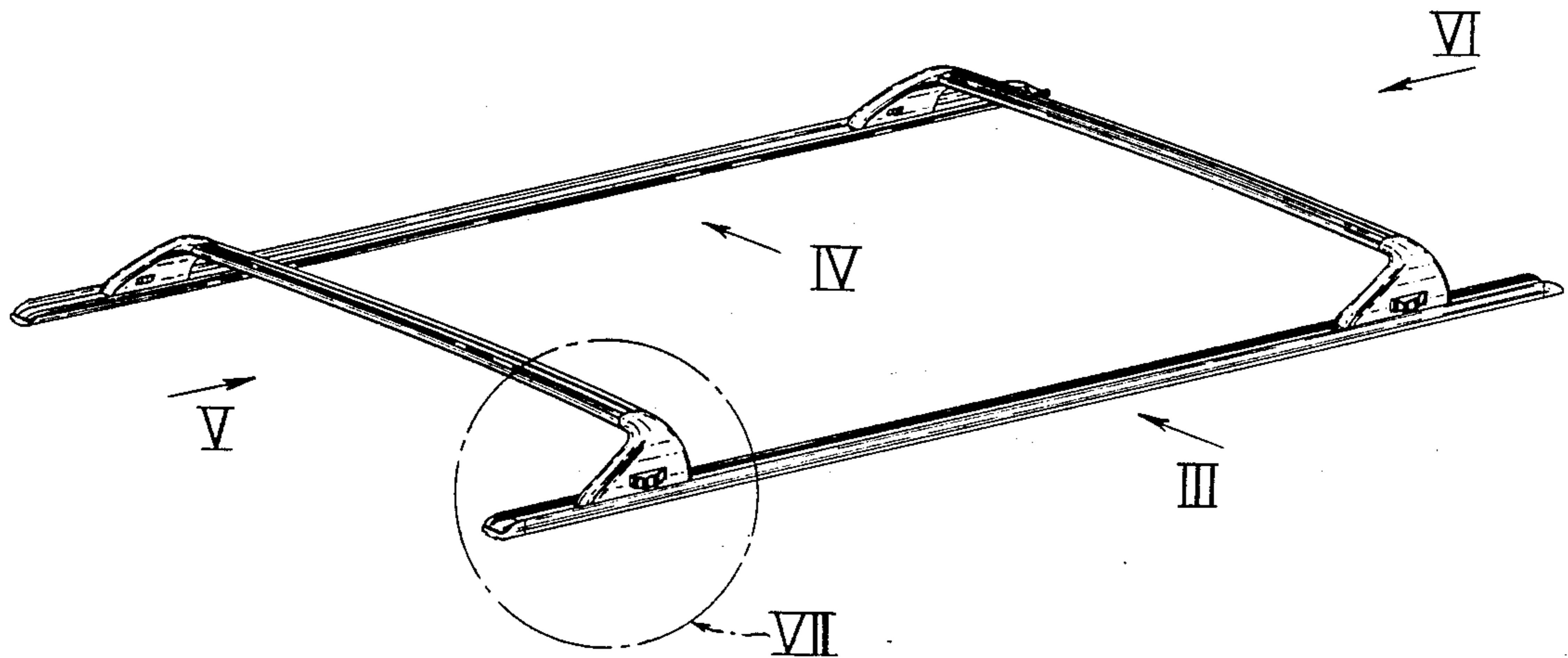

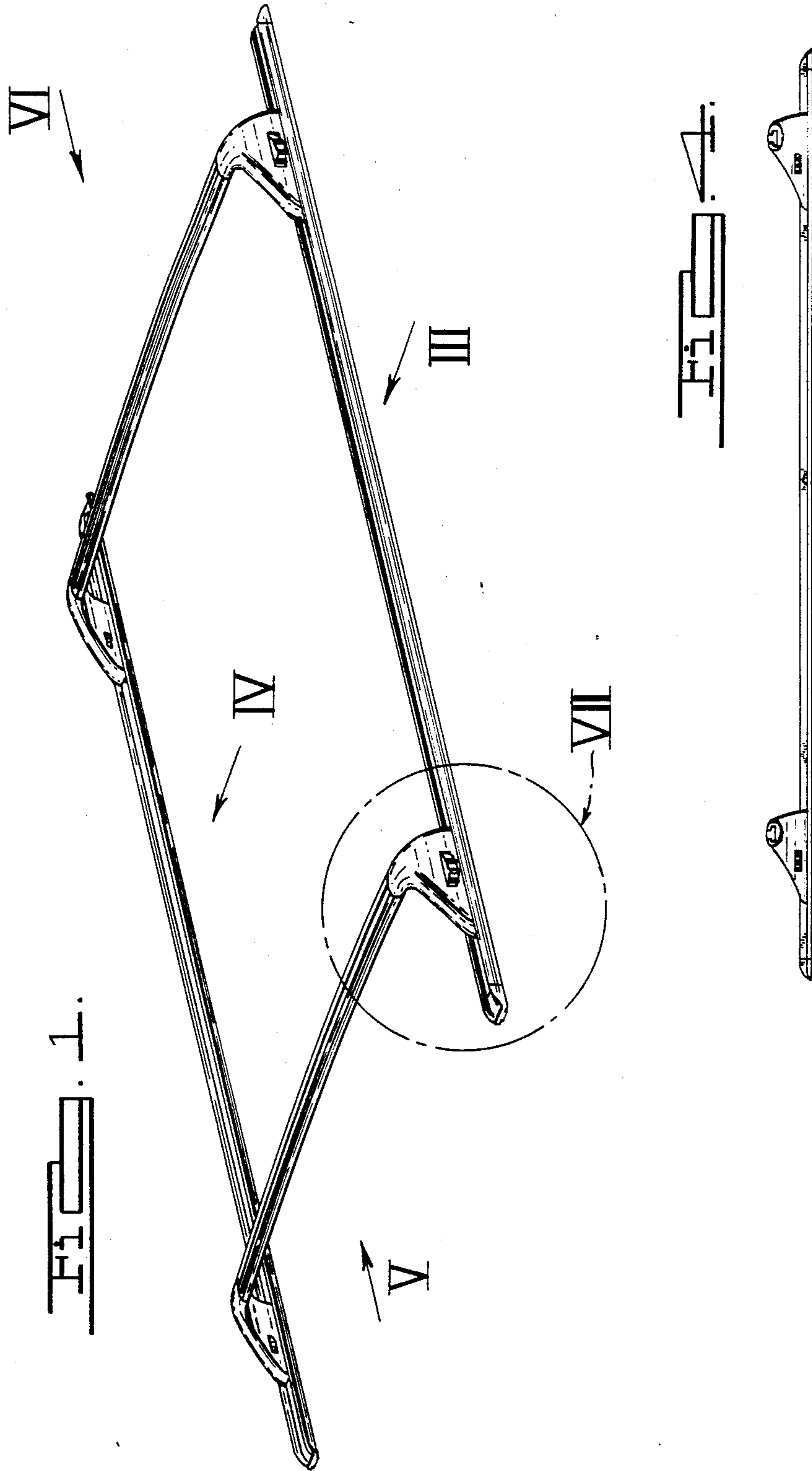

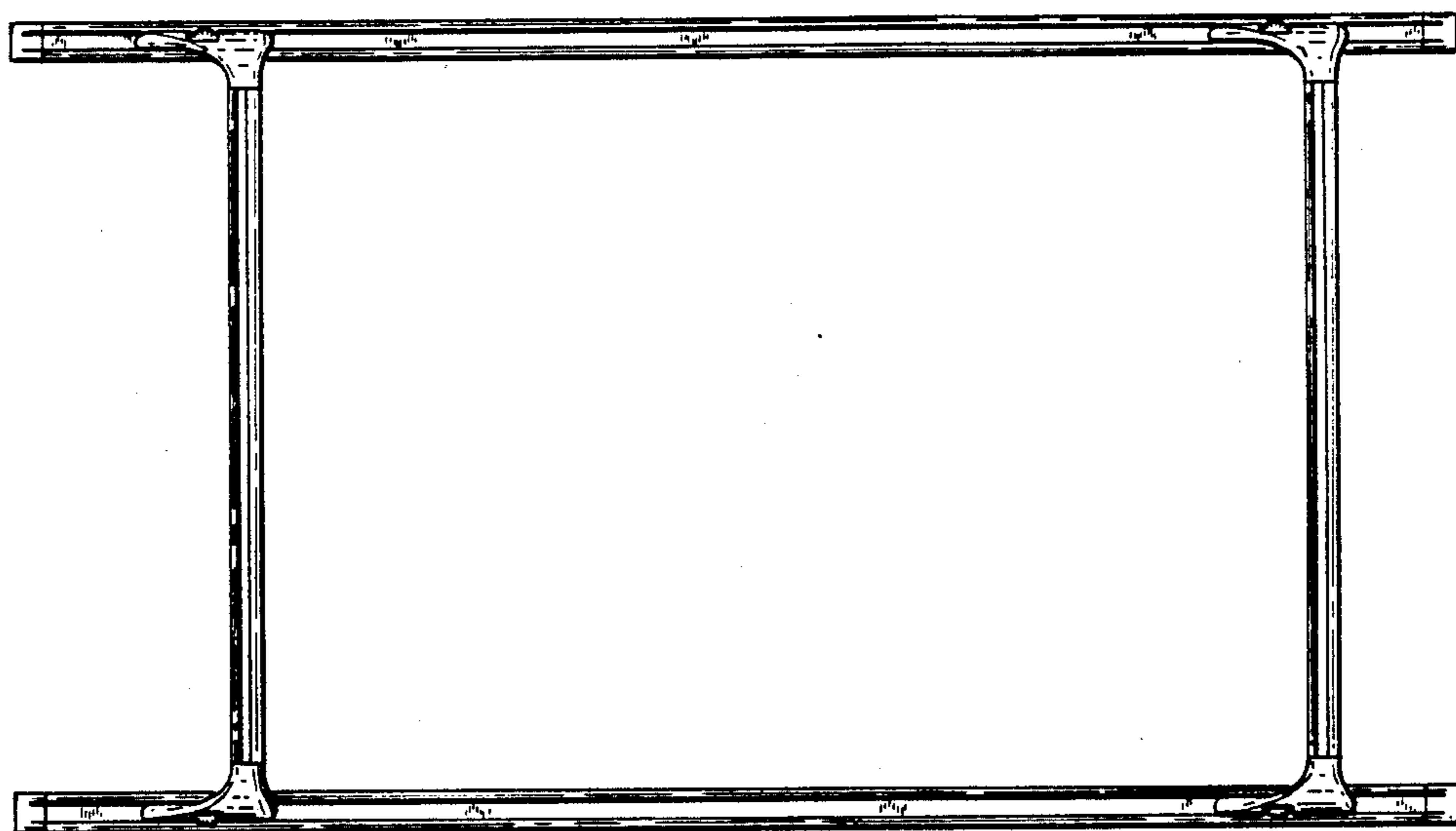

FIG. 2.



FIG. 3.

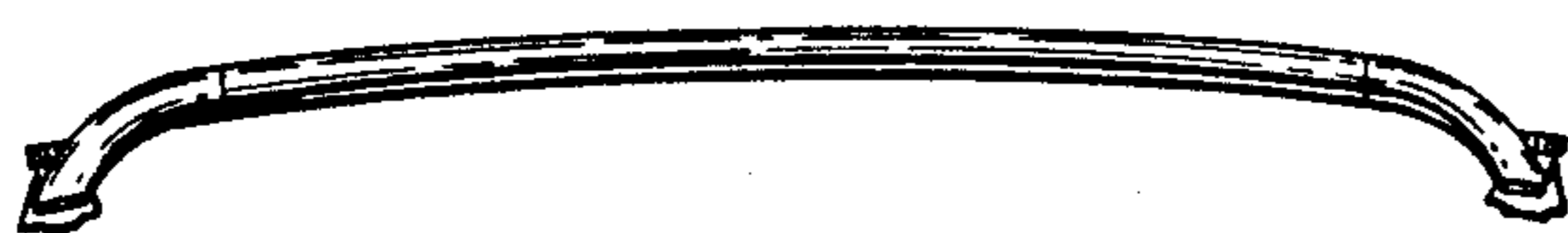

FIG. 5.



FIG. 6.

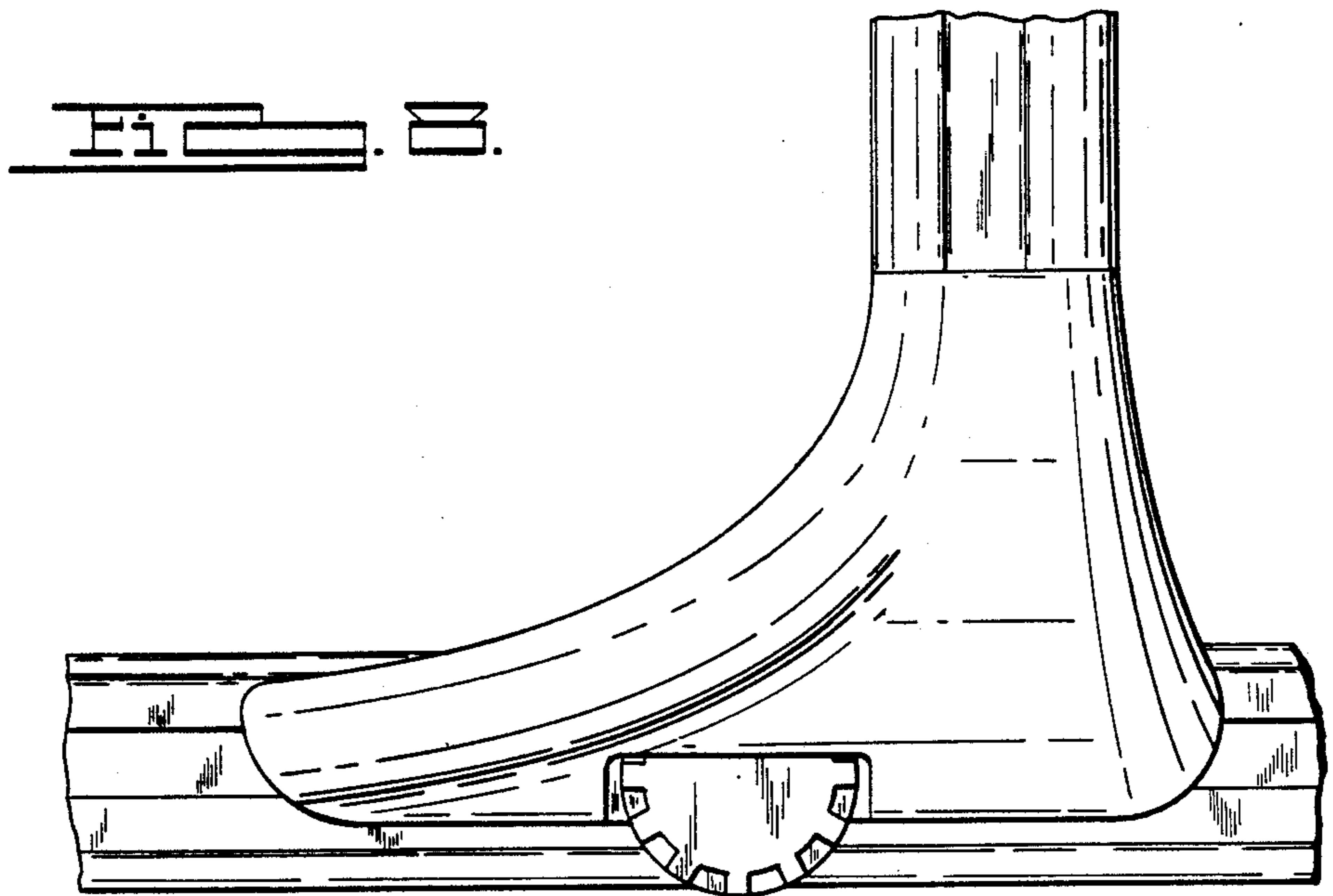
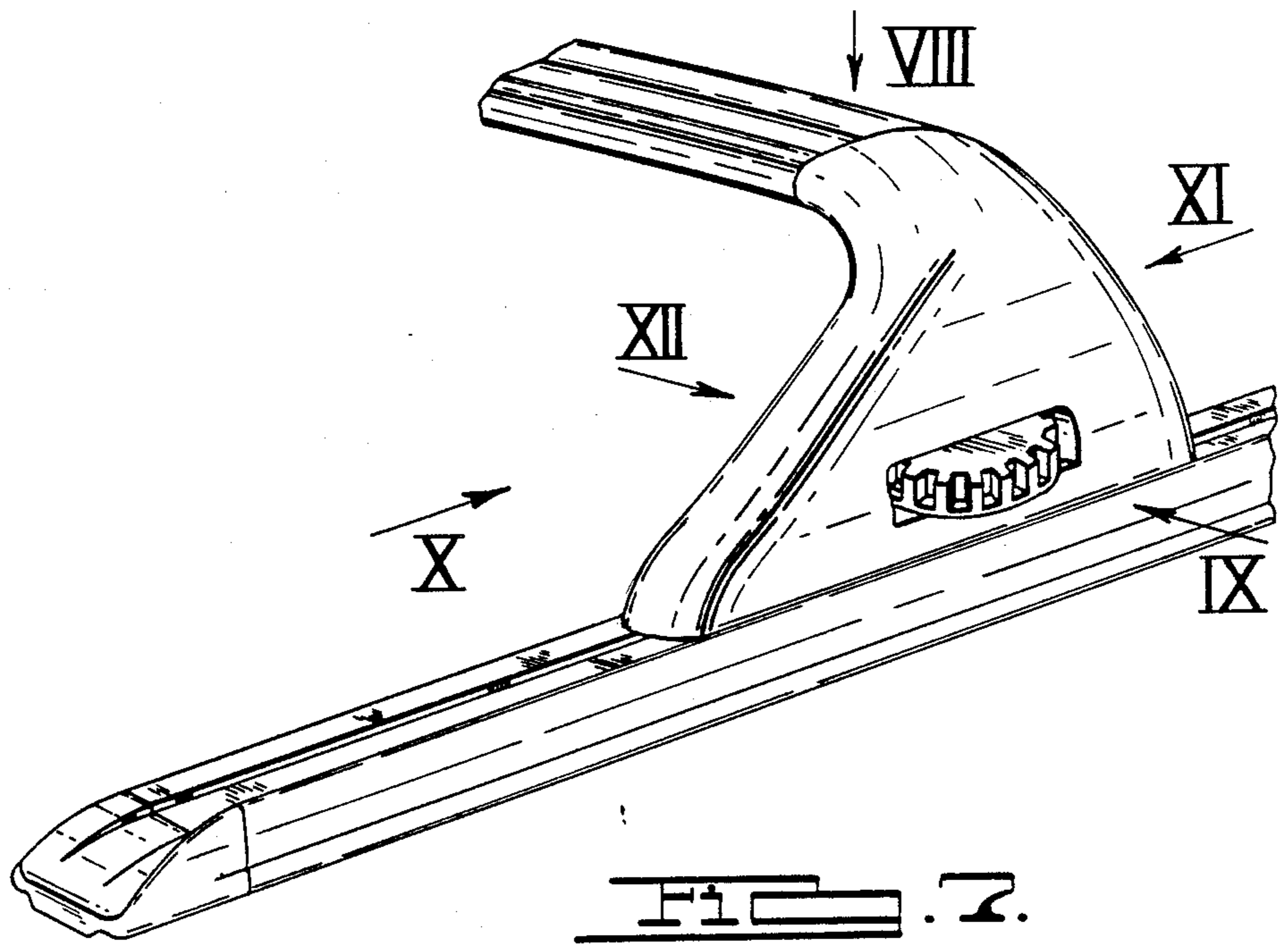

Fig. 9.

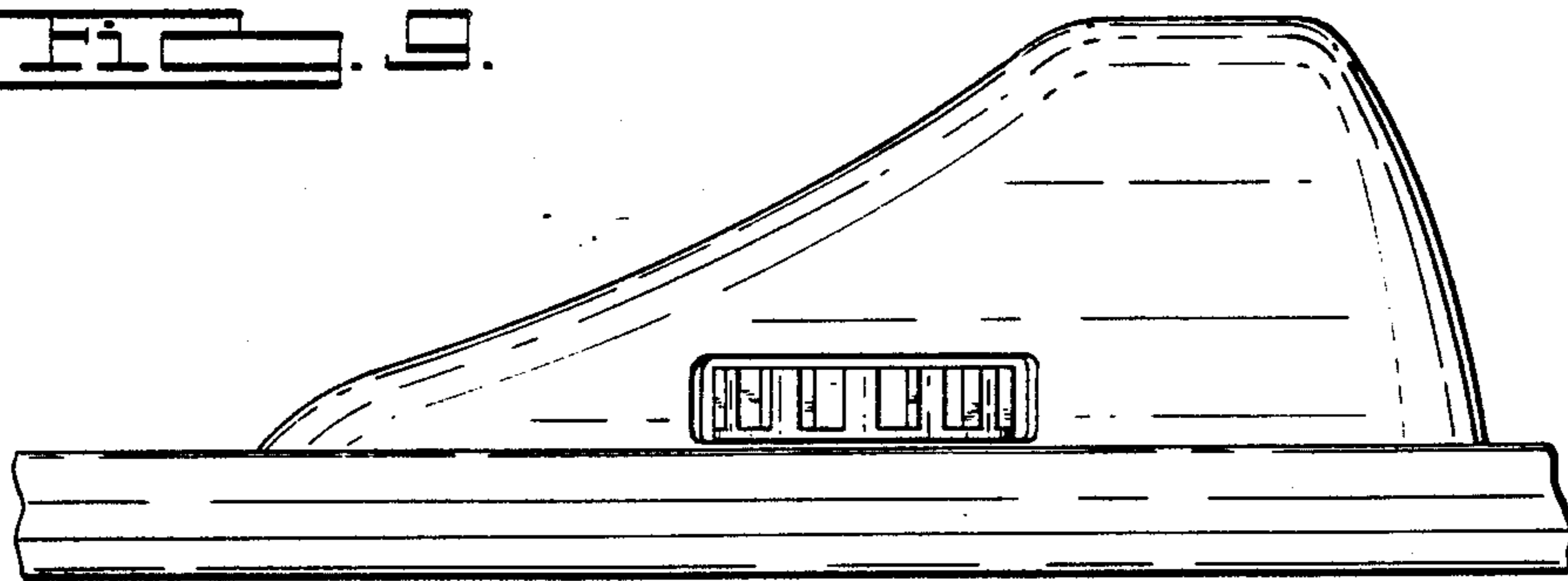

Fig. 10.

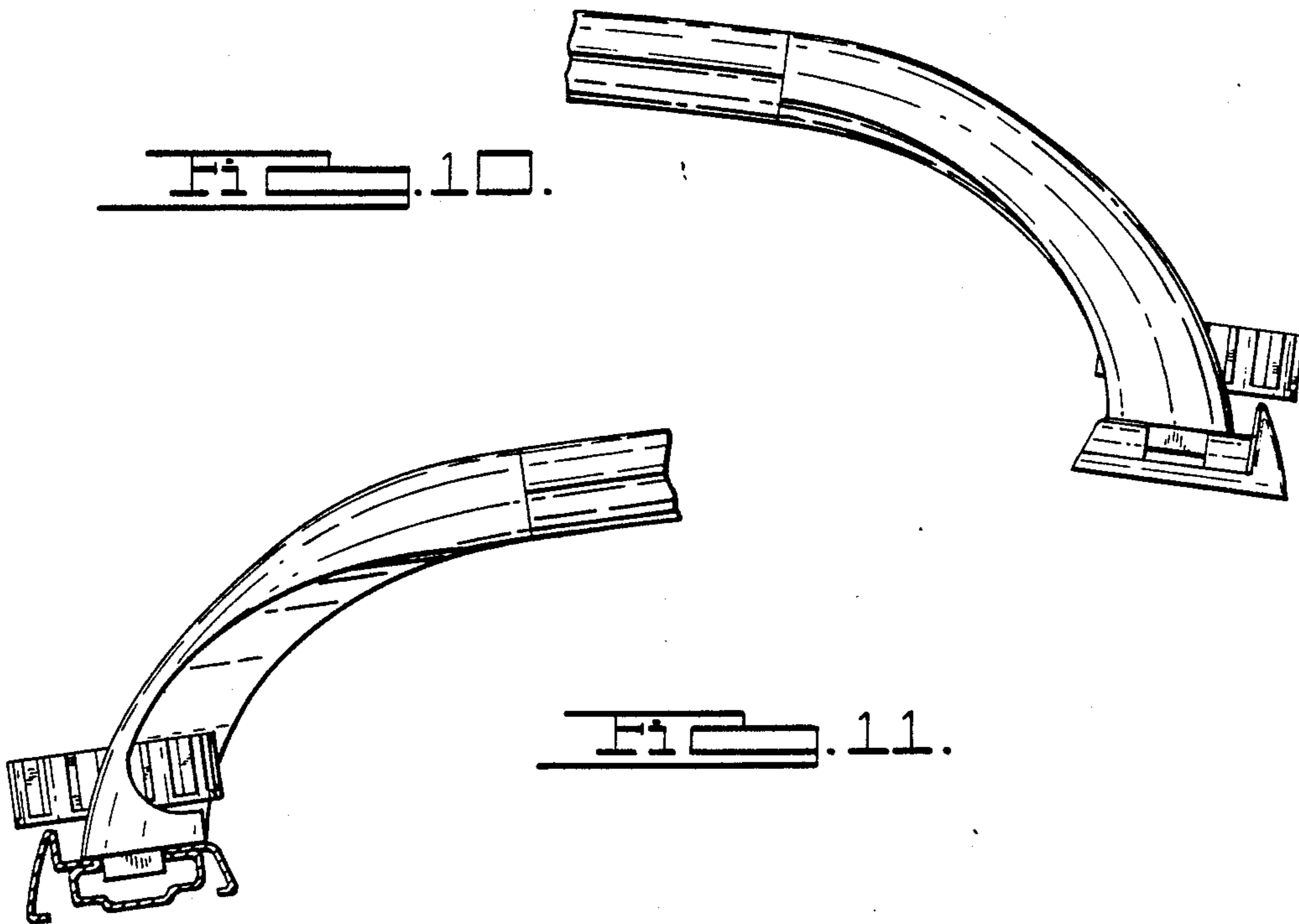

Fig. 11.

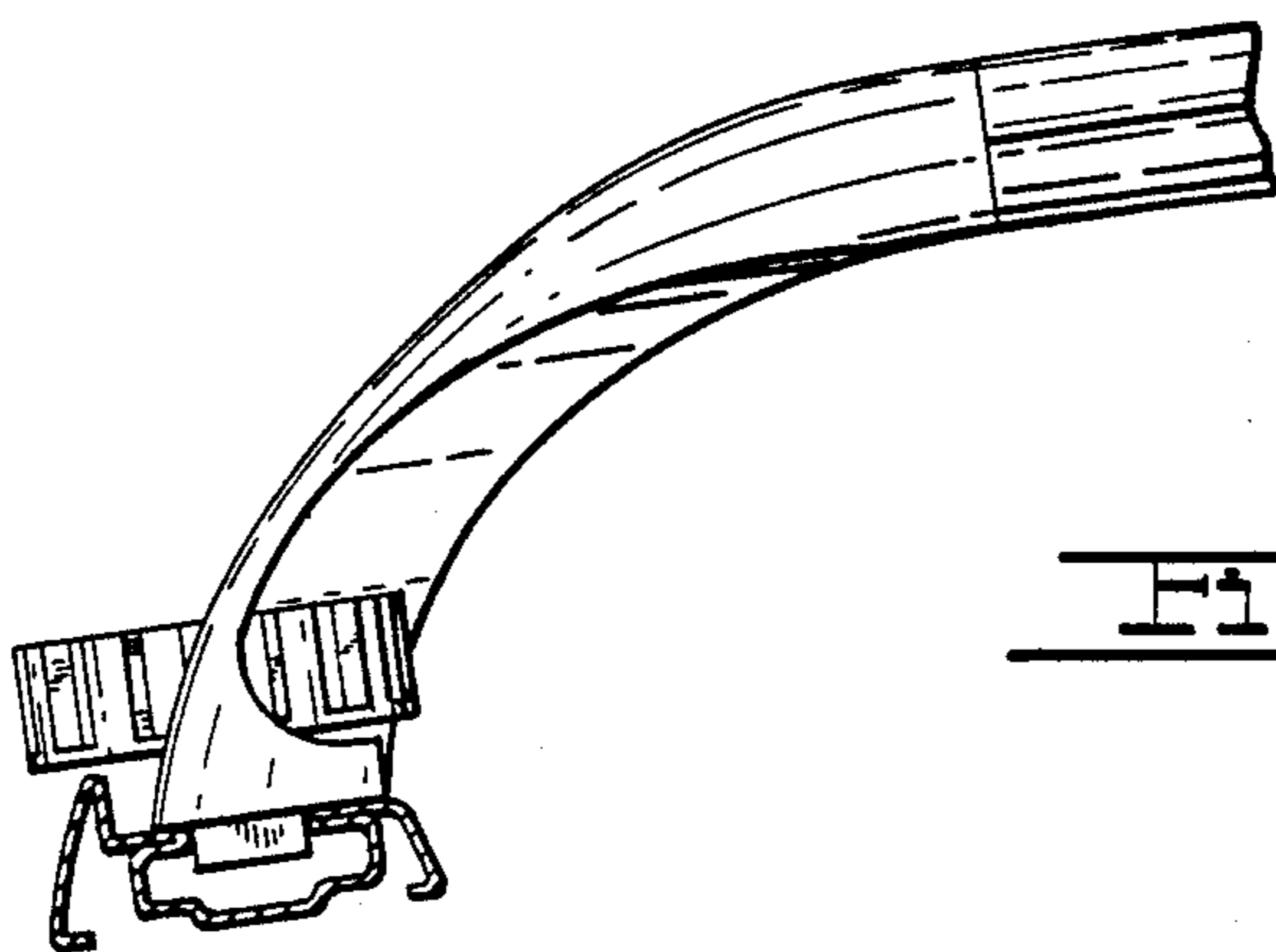

Fig. 12.

