

[54] **PEDAL AND ARM EXERCISE MACHINE**
 [75] **Inventors: Gerald Pitzen, Arden Hills; Douglas Garfield, Northfield; Joseph C. Bina, Oakdale, all of Minn.**
 [73] **Assignee: Bioform Engineering, Incorporated, Ross, Calif.**
 [**] **Term: 14 Years**
 [21] **Appl. No.: 176,412**
 [22] **Filed: Apr. 1, 1988**
 [52] **U.S. Cl. D21/194**
 [58] **Field of Search D21/191-199; 272/73, 73.1, 70.1, 70.2, 70.3, 132; 73/379; D6/374, 375**

D. 246,812 1/1978 Canter et al. D6/375
 D. 283,636 4/1986 Lepley D21/194
 D. 298,641 11/1988 Sheltra D21/194
 4,589,656 5/1986 Baldwin 272/73

*Primary Examiner—Charles A. Rademaker
 Attorney, Agent, or Firm—Kinney & Lange*

[57] **CLAIM**

The ornamental design for pedal and arm exercise machine, as shown and described.

DESCRIPTION

FIG. 1 is a perspective view of pedal and arm exercise machine showing our new design;
 FIG. 2 is a front elevational view thereof;
 FIG. 3 is a rear elevational view thereof;
 FIG. 4 is a top plan view thereof;
 FIG. 5 is a side elevational view thereof;
 FIG. 6 is a side elevational view thereof; and
 FIG. 7 is a bottom plan view.

[56] **References Cited**
U.S. PATENT DOCUMENTS
 D. 218,107 7/1970 Feather et al. D21/194

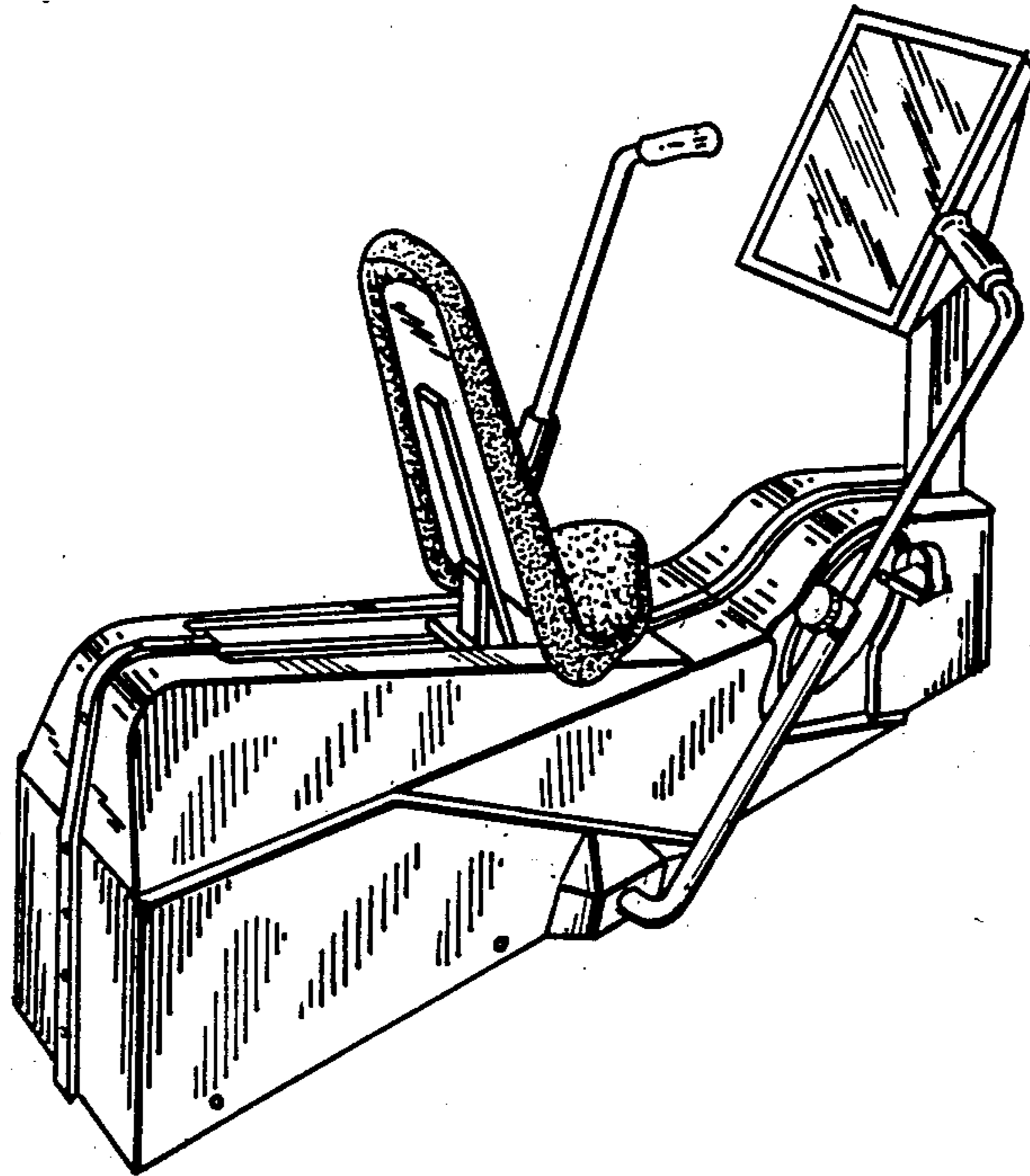

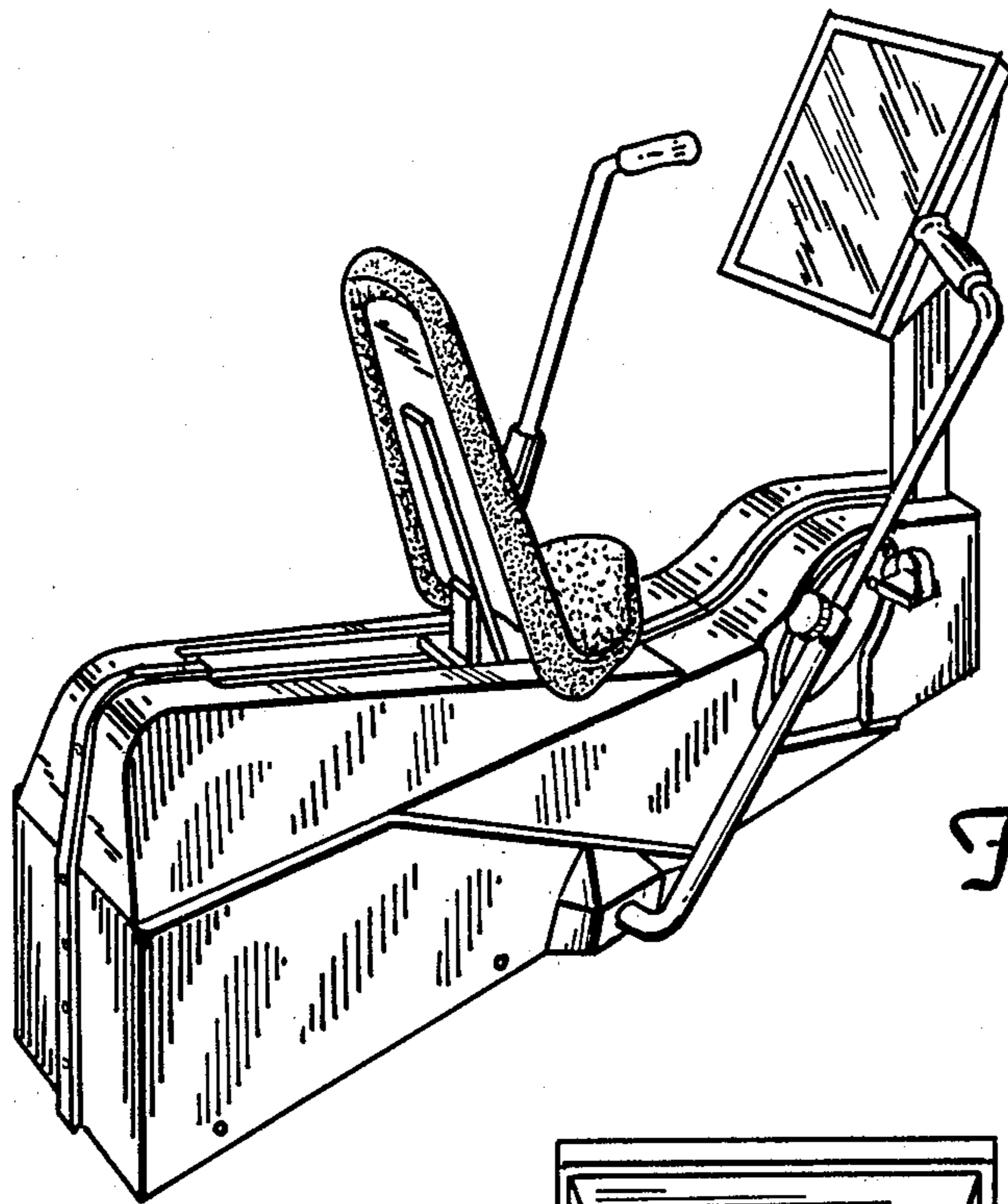

Fig. 1

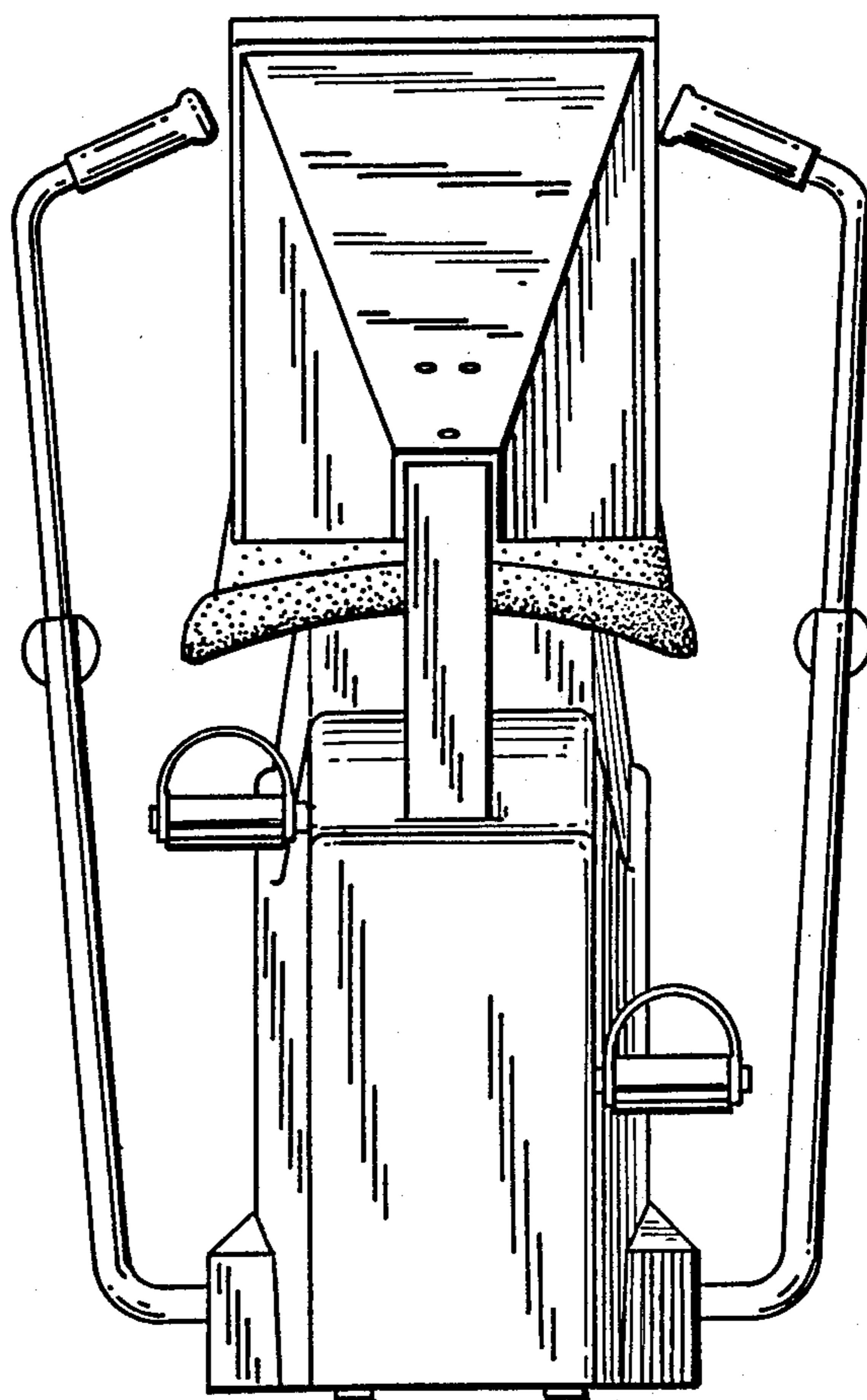

Fig. 2

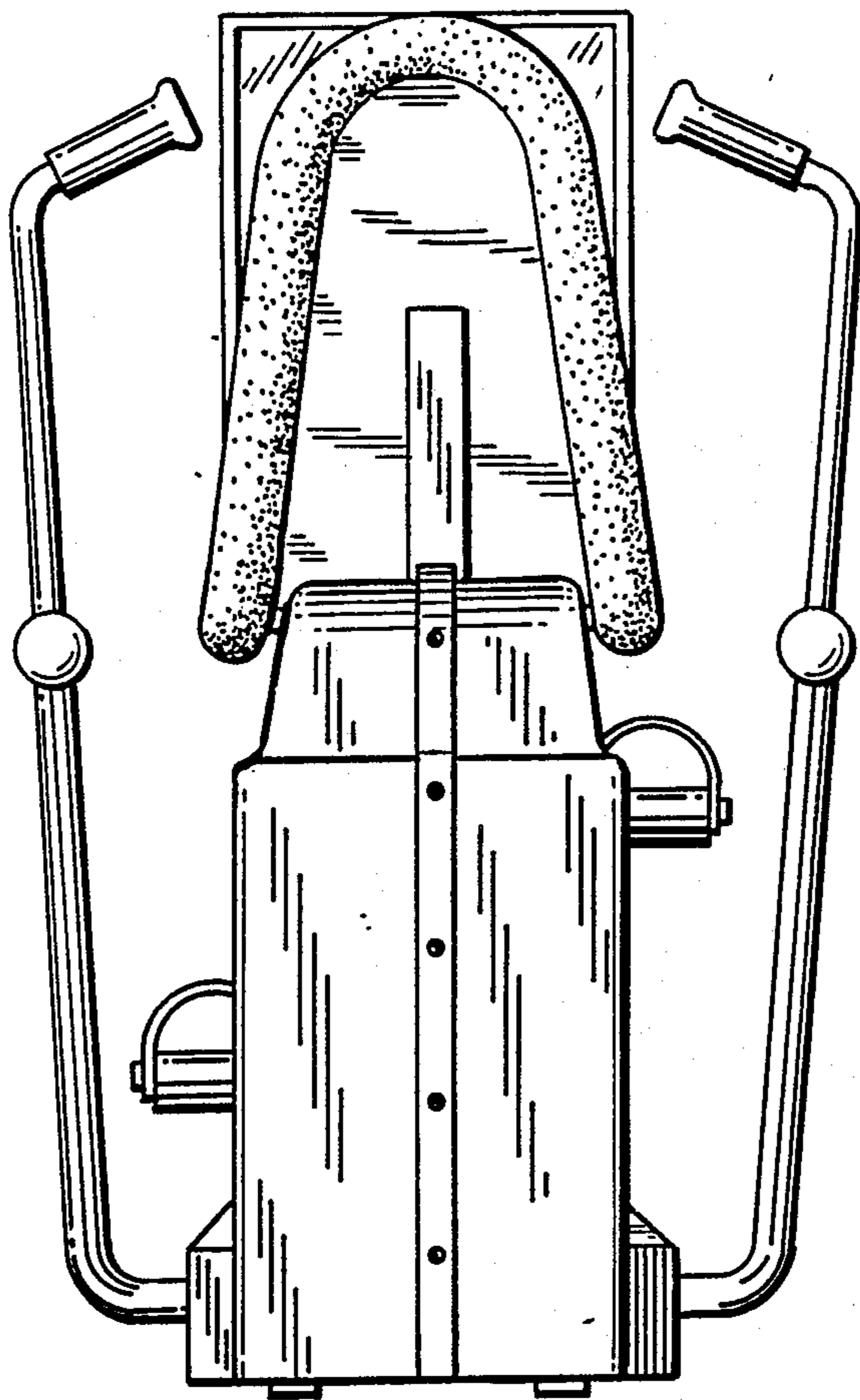

Fig. 3

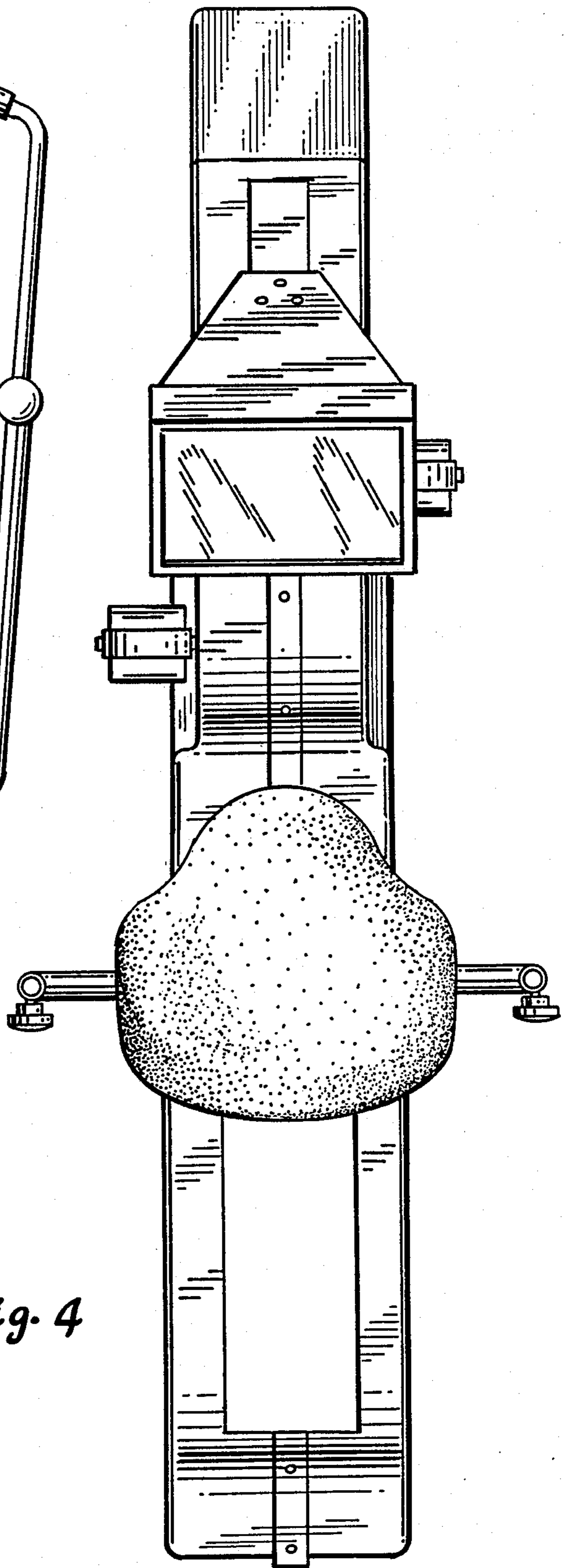
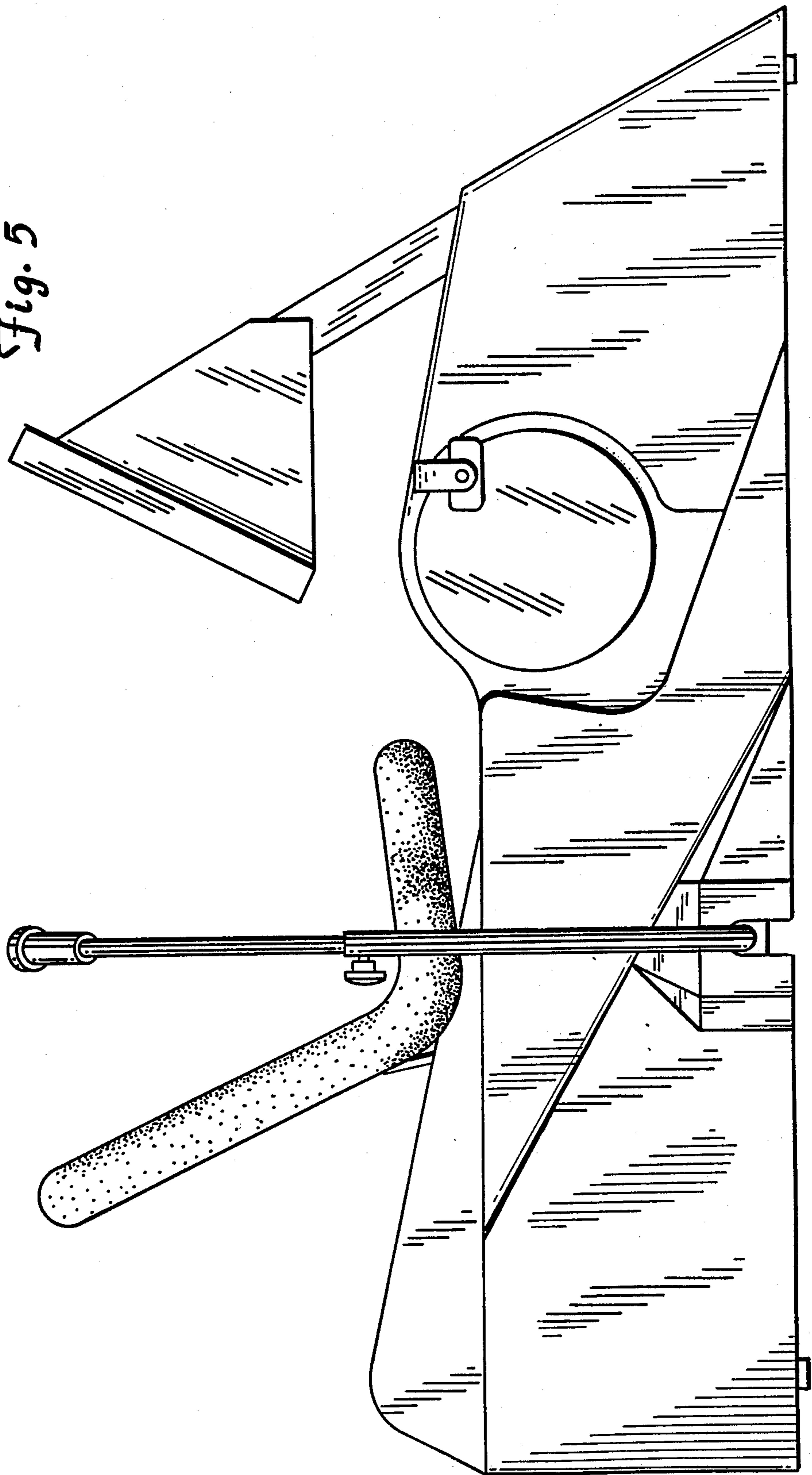
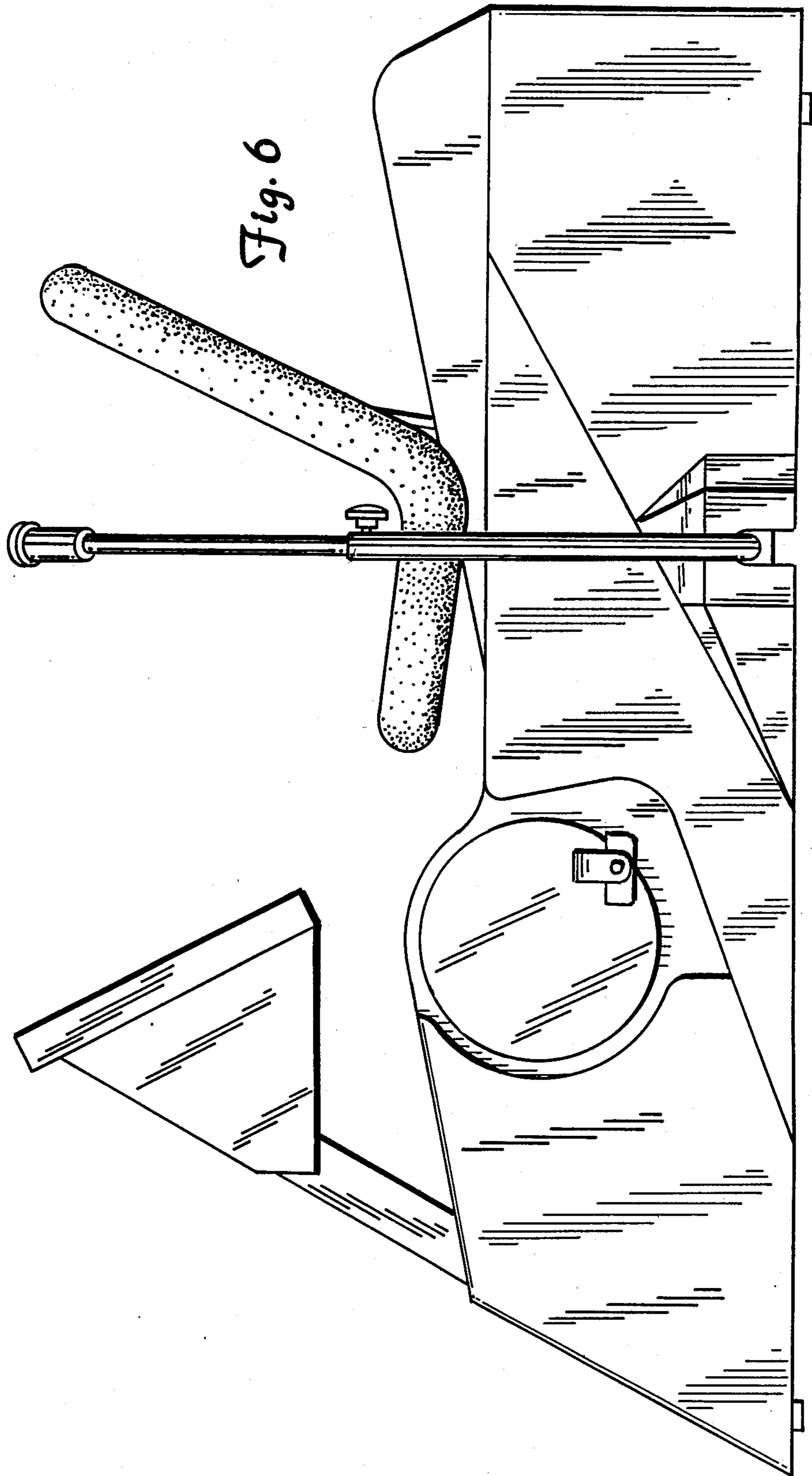

Fig. 4

Fig. 5





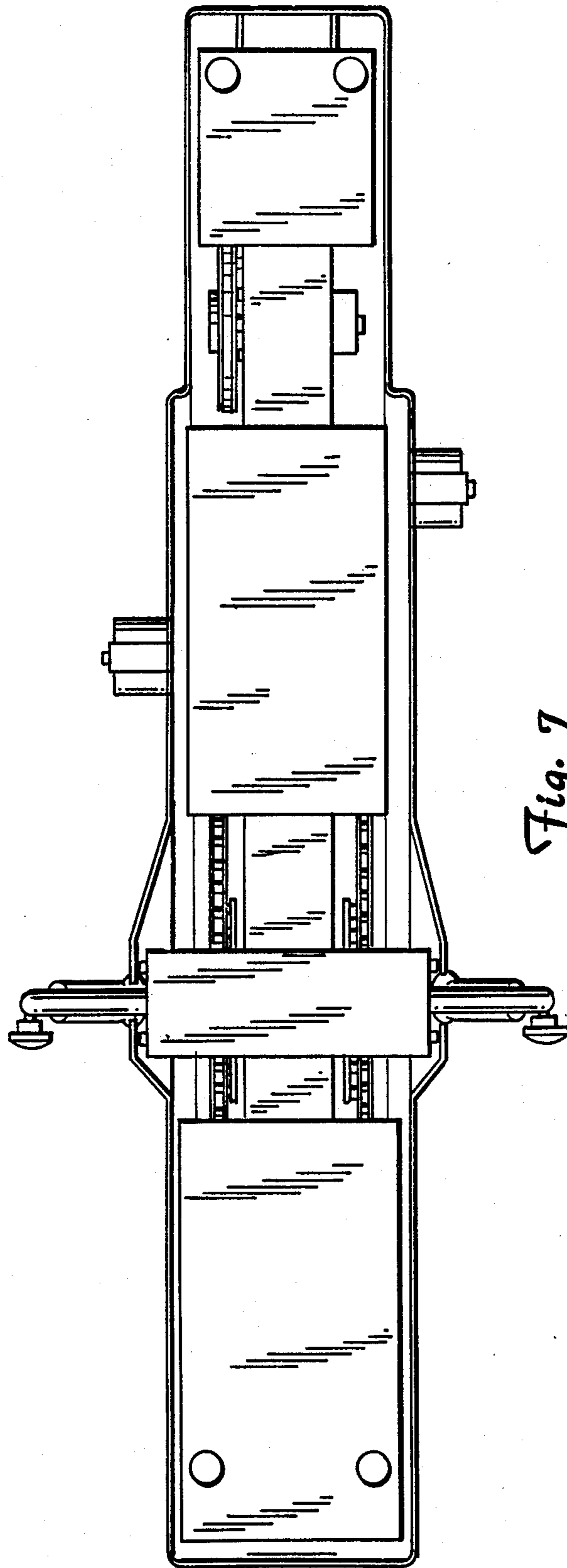

Fig. 7