

[54] **LAMP**

[75] **Inventor: Ernest J. Pavelin, Essex, England**

[73] **Assignee: Thorn EMI plc, London, England**

[\*\*] **Term: 14 Years**

[21] **Appl. No.: 3,685**

[22] **Filed: Jan. 15, 1987**

[30] **Foreign Application Priority Data**

Jul. 15, 1986 [GB] United Kingdom ..... 1035394

[52] **U.S. Cl. .... D26/2**

[58] **Field of Search ..... D26/1, 2, 3; 313/315, 313/317, 318, 110, 113, 116, 491, 493, 567, 569, 25; 315/56, 57, 58, 73; 362/216, 297, 307, 309, 310**

[56] **References Cited**

**U.S. PATENT DOCUMENTS**

D. 286,914 11/1986 Bedel ..... D26/3  
4,503,360 3/1985 Bedel ..... 313/493 X

*Primary Examiner*—Susan J. Lucas  
*Attorney, Agent, or Firm*—Fleit, Jacobson, Cohn, Price, Holman & Stern

[57] **CLAIM**

The ornamental design for a lamp, as shown.

**DESCRIPTION**

FIG. 1 is a perspective view from the front and one side of a lamp showing my new design;

FIG. 2 is a perspective view from the rear and other side thereof;

FIG. 3 is a front elevational view thereof;

FIG. 4 is a rear elevational view thereof; and

FIG. 5 is a side elevational view thereof.

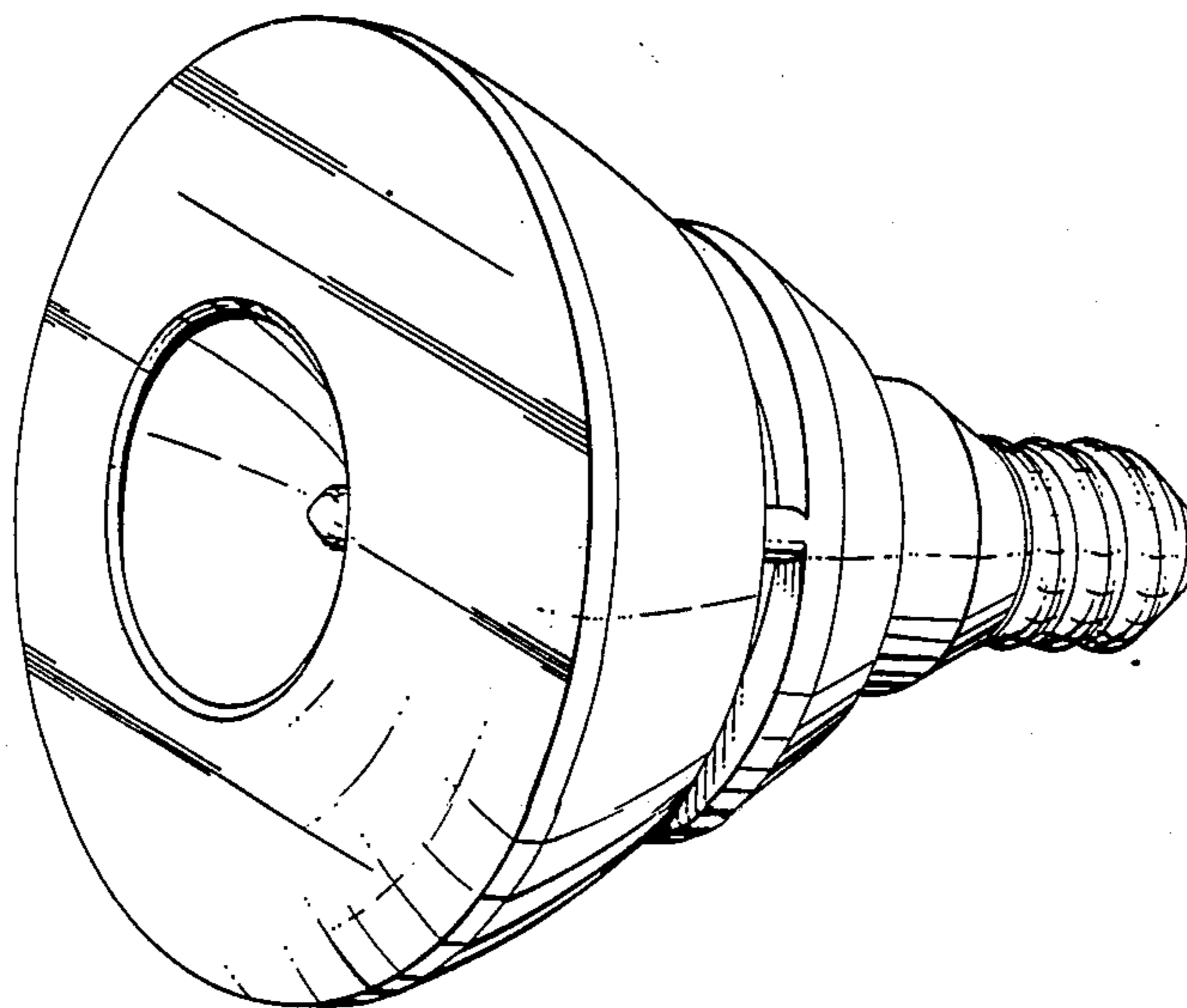

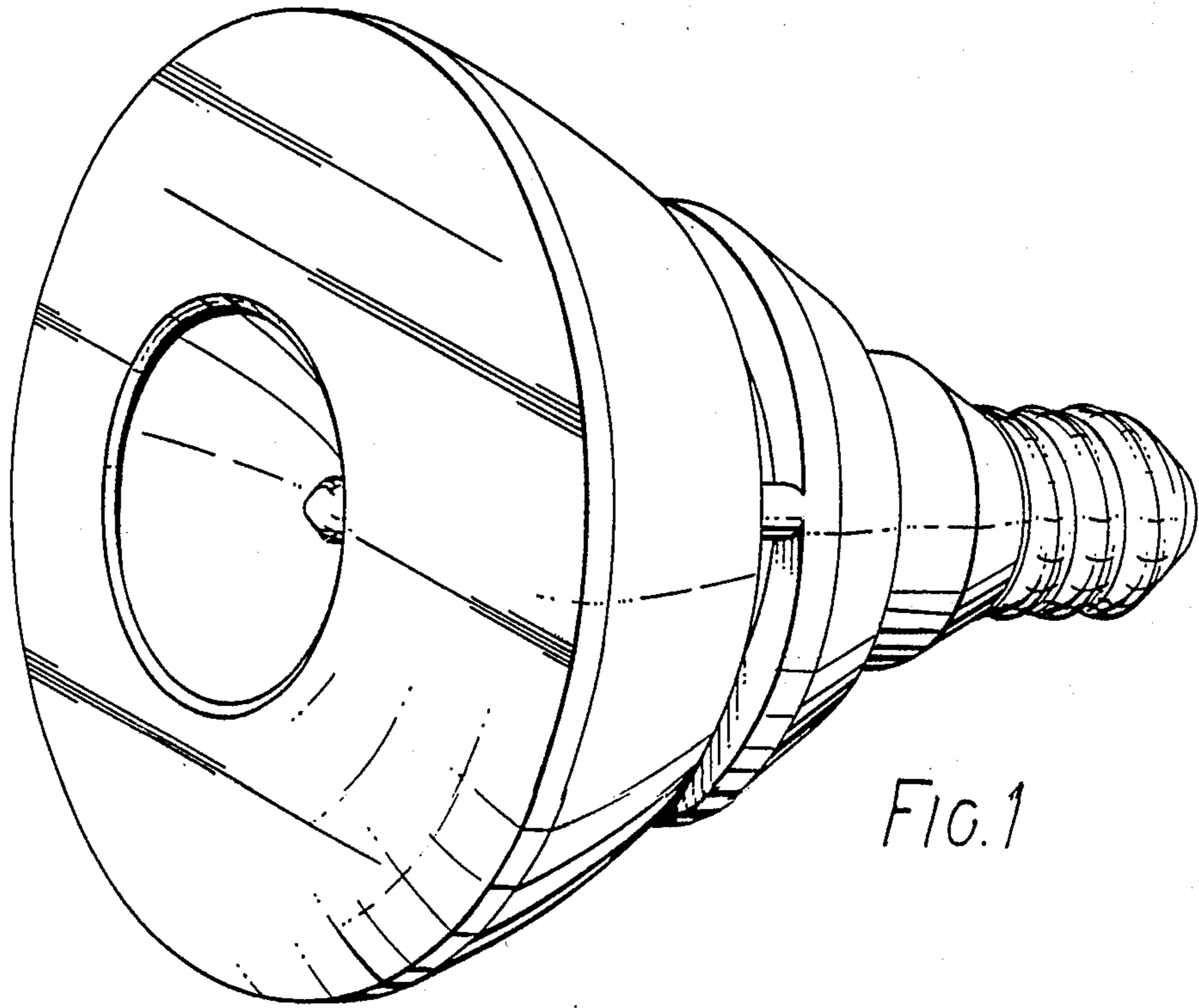

FIG. 1

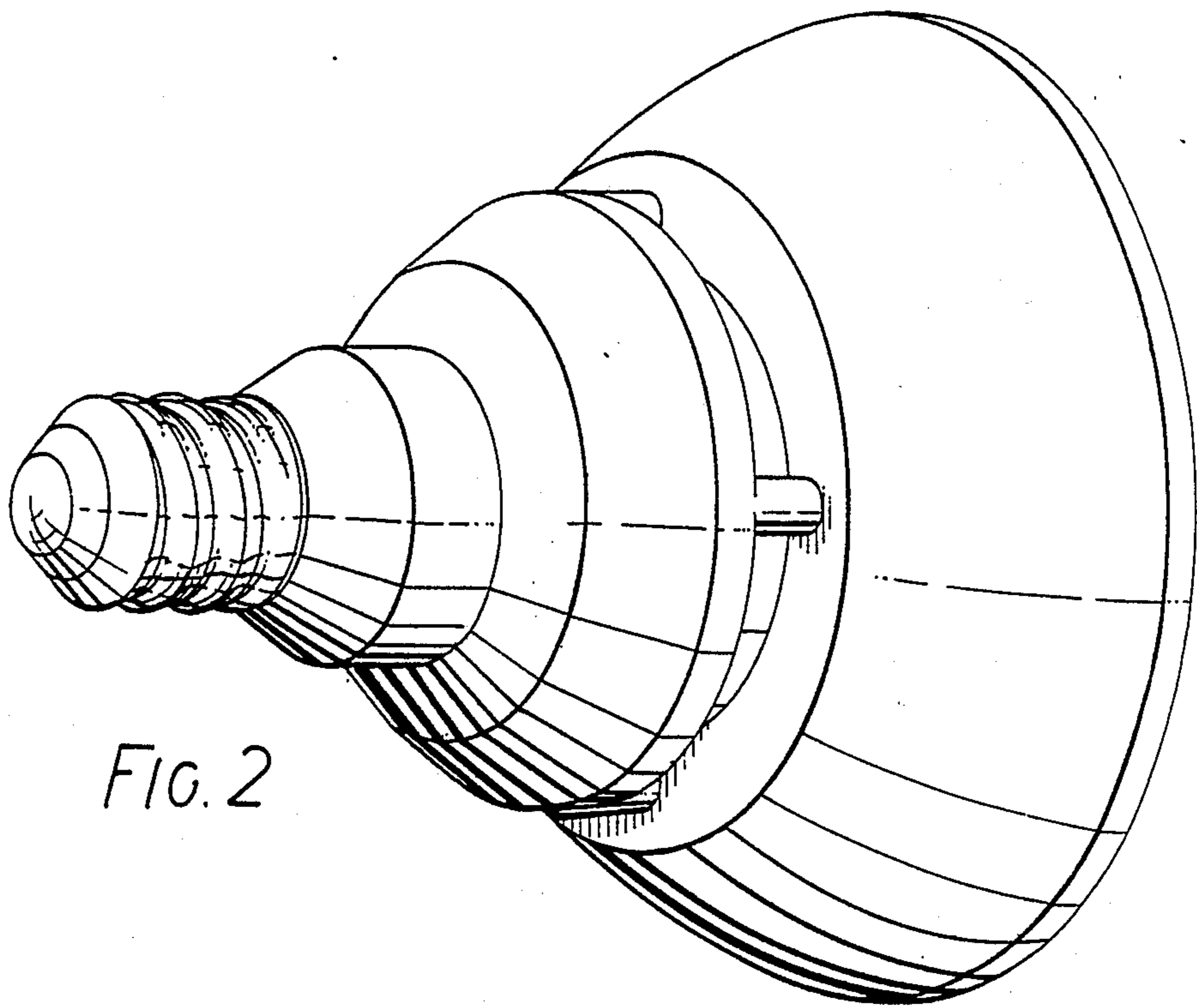

FIG. 2

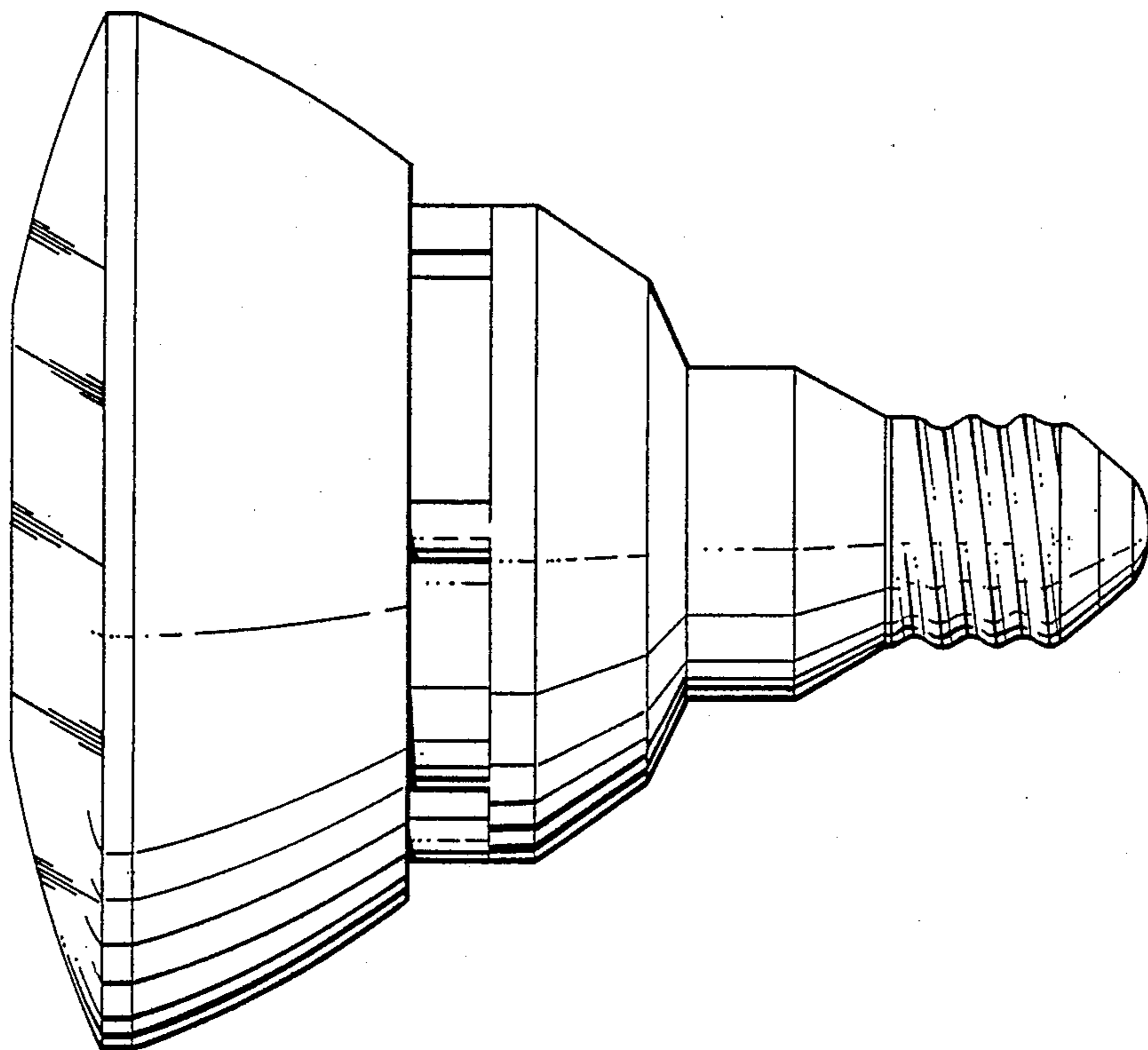

FIG. 3

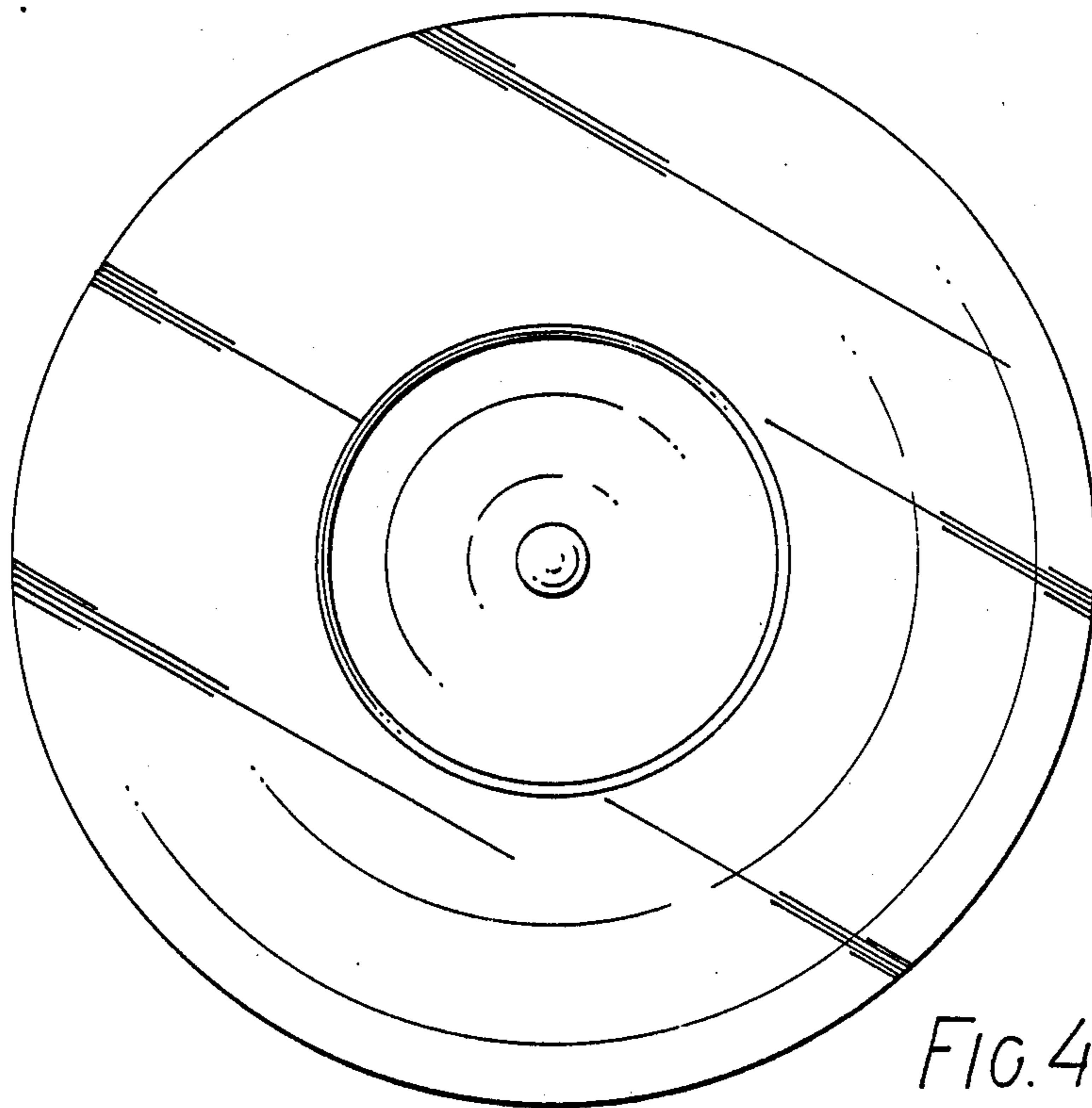

FIG. 4

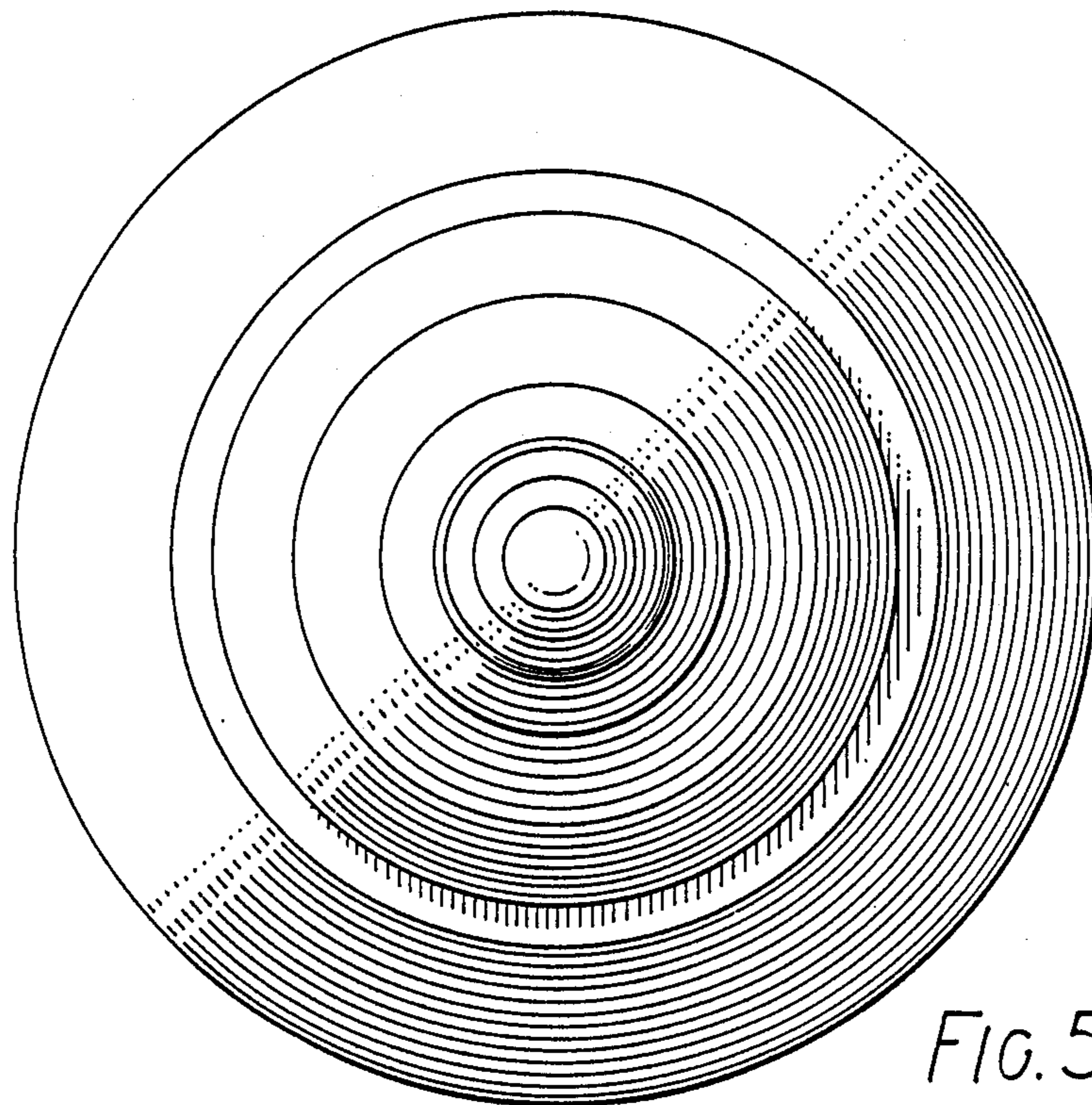

FIG. 5