

[54] SUPERCONDUCTING MAGNET FOR MAGNETIC RESONANCE IMAGING APPARATUSES

[75] Inventors: Kinya Matsutani, Yokohama; Hirotsugu Ohguma, Tokyo, both of Japan

[73] Assignee: Kabushiki Kaisha Toshiba, Kawasaki, Japan

[**] Term: 14 Years

[21] Appl. No.: 101,165

[22] Filed: Sep. 25, 1987

[30] Foreign Application Priority Data

Mar. 27, 1987 [JP] Japan 62-11243

[52] U.S. Cl. D13/99; D24/1.1

[58] Field of Search D13/99; D24/1.1, 2; 335/301, 299

[56] References Cited

U.S. PATENT DOCUMENTS

D. 258,084	1/1981	Weingarten	D24/1.1
3,461,329	2/1968	Shartrand et al.	D13/1
4,587,504	5/1986	Brown et al.	335/229
4,660,013	4/1987	Laskaris et al.	335/229
4,694,269	9/1987	Burnett et al.	335/229

OTHER PUBLICATIONS

"Active-Shield Magnet" (OXFORD) received by the assignee Company on Nov. 25, 1986.

"Journal of NMR Medicine" vol. 6, Supplement-2 published Sep. 6, 1986.

Primary Examiner—Susan J. Lucas
Assistant Examiner—Joel Sincavage
Attorney, Agent, or Firm—Oblon, Spivak, McClelland, Maier & Neustadt

[57] CLAIM

The ornamental design for a superconducting magnet for magnetic resonance imaging apparatuses, as shown and described.

DESCRIPTION

FIG. 1 is a front and right side perspective view of a superconducting magnet for magnetic resonance imaging apparatuses showing our new design; FIG. 2 is a front elevational view thereof; FIG. 3 is a rear elevational view thereof; FIG. 4 is a top plan view thereof; FIG. 5 is a right side elevational view thereof; FIG. 6 is a left side elevational view thereof; FIG. 7 is a bottom plan view thereof; FIG. 8 is a sectional view thereof taken on line 8—8' of FIG. 5 with the interior mechanism omitted; and FIG. 9 is a sectional view thereof taken on line 9—9' of FIG. 2 with the interior mechanism omitted.

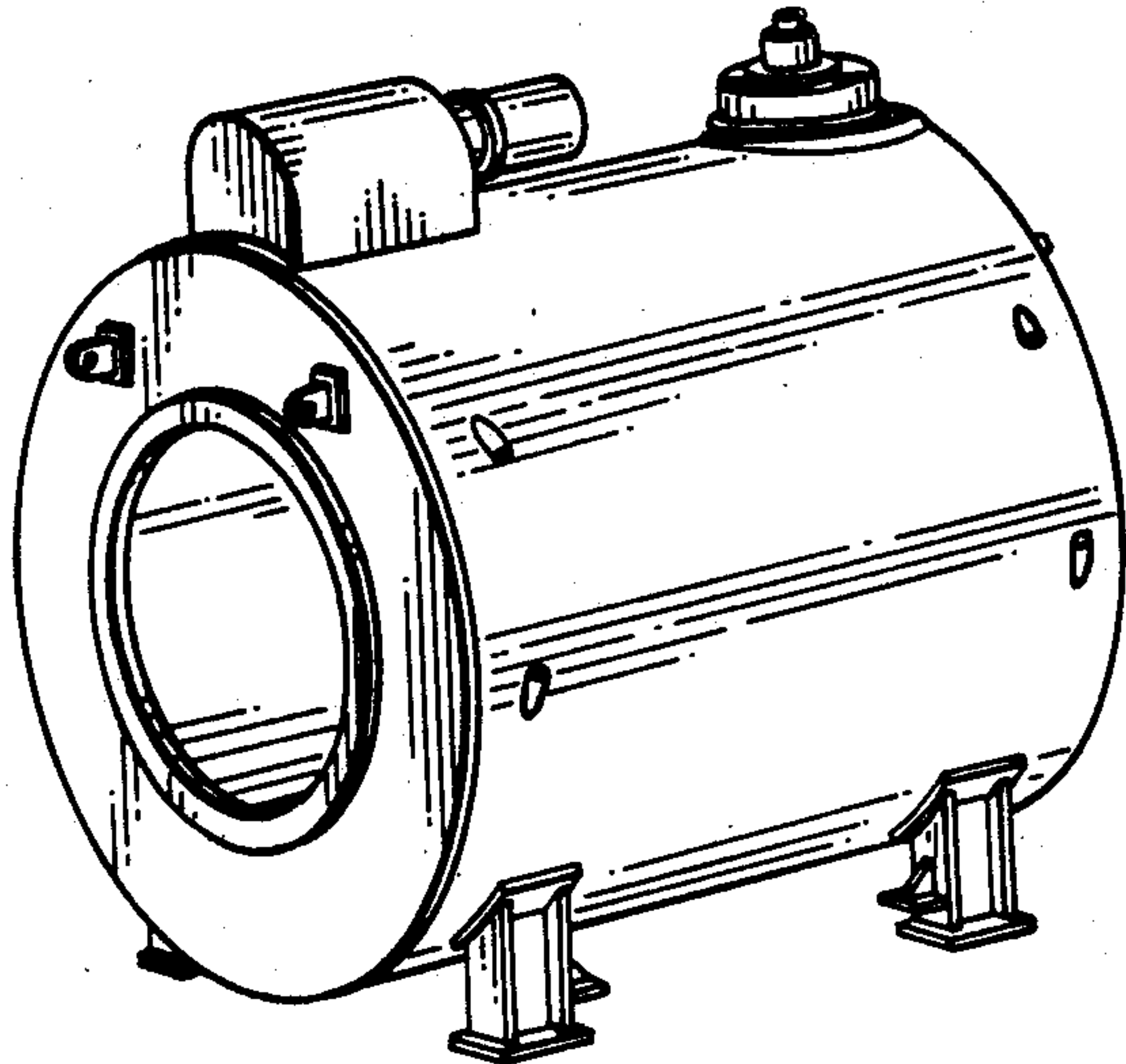

FIG. 1

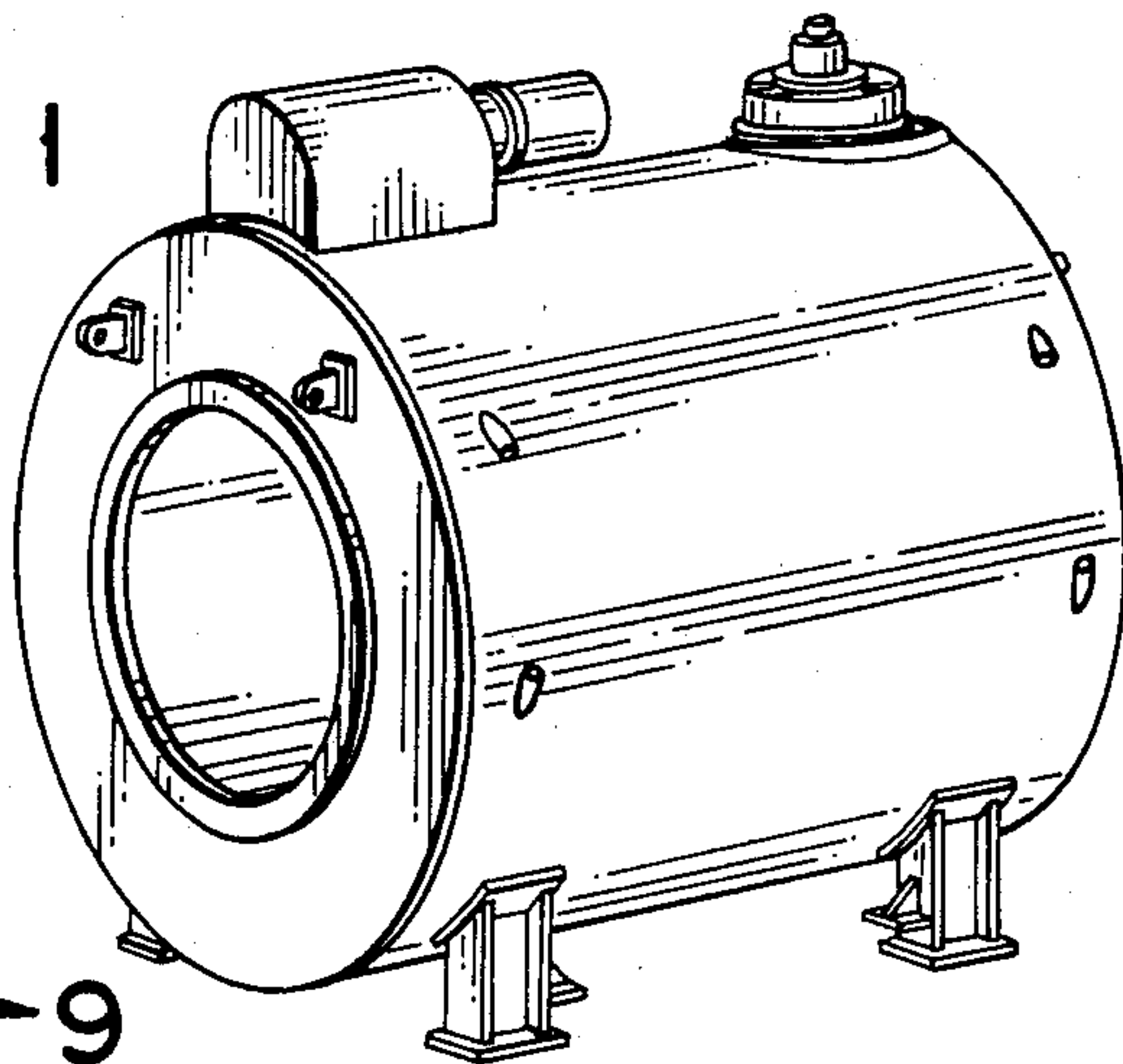

FIG. 2 ↗ 9

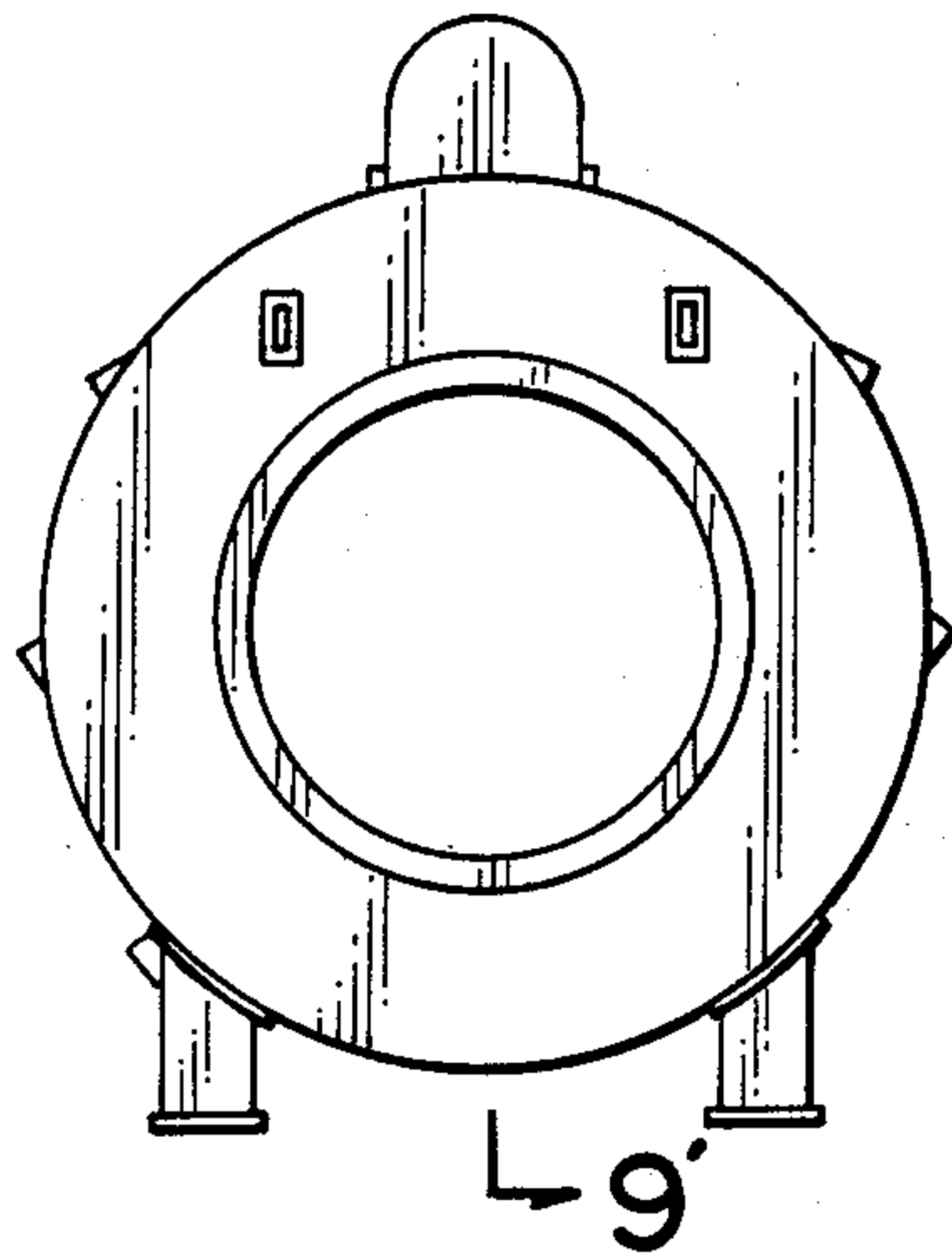

FIG. 3

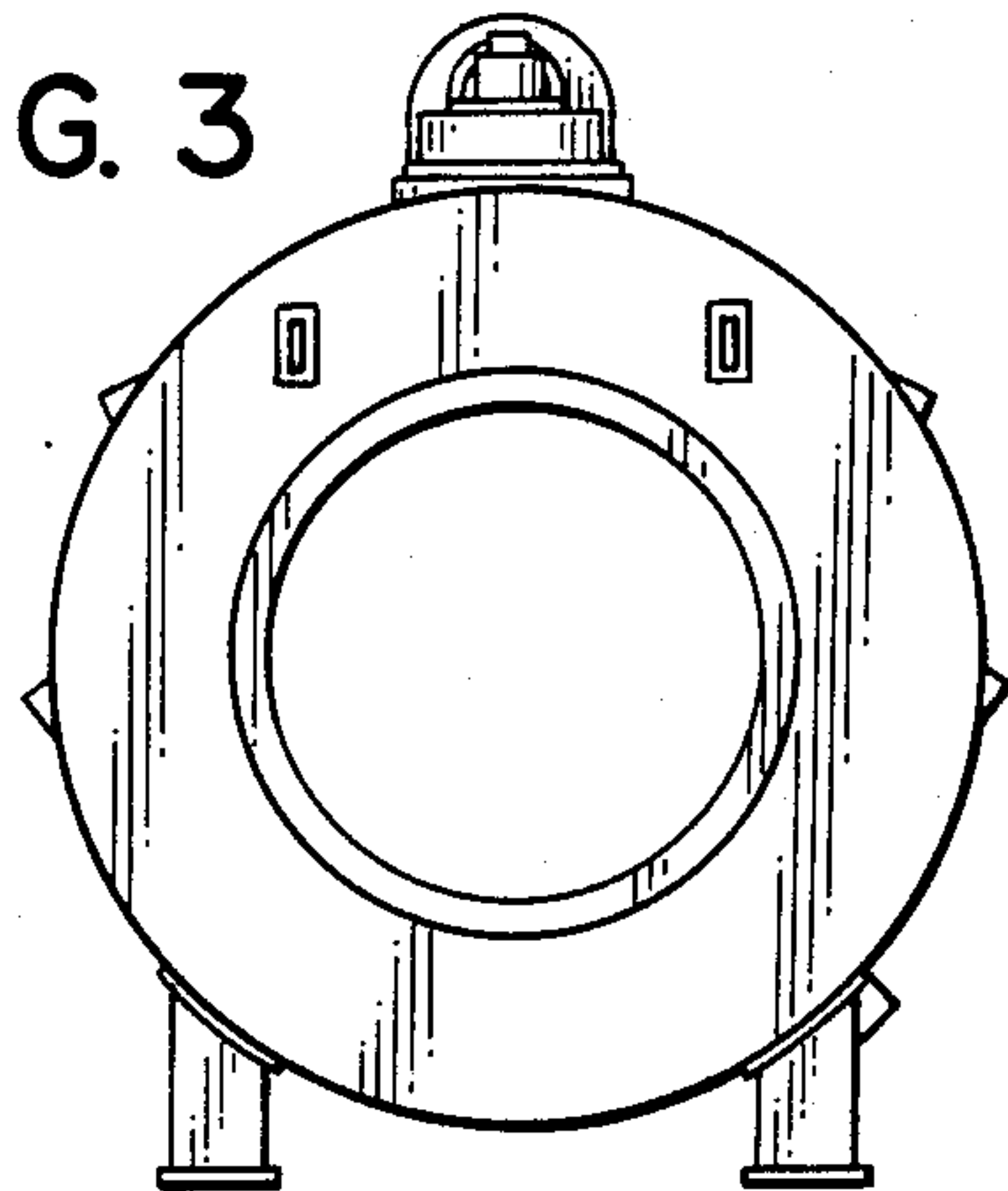

FIG. 4

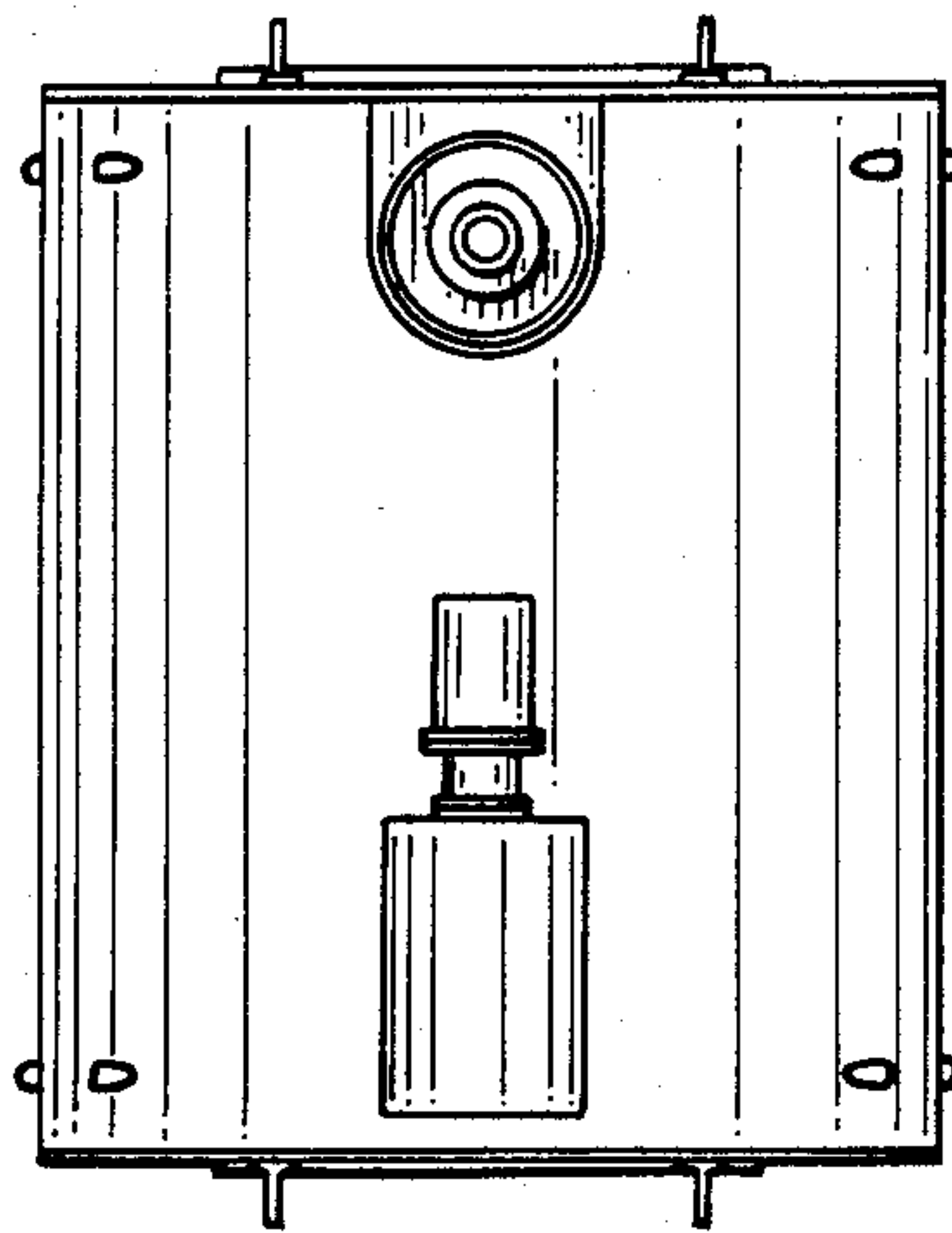

FIG. 5

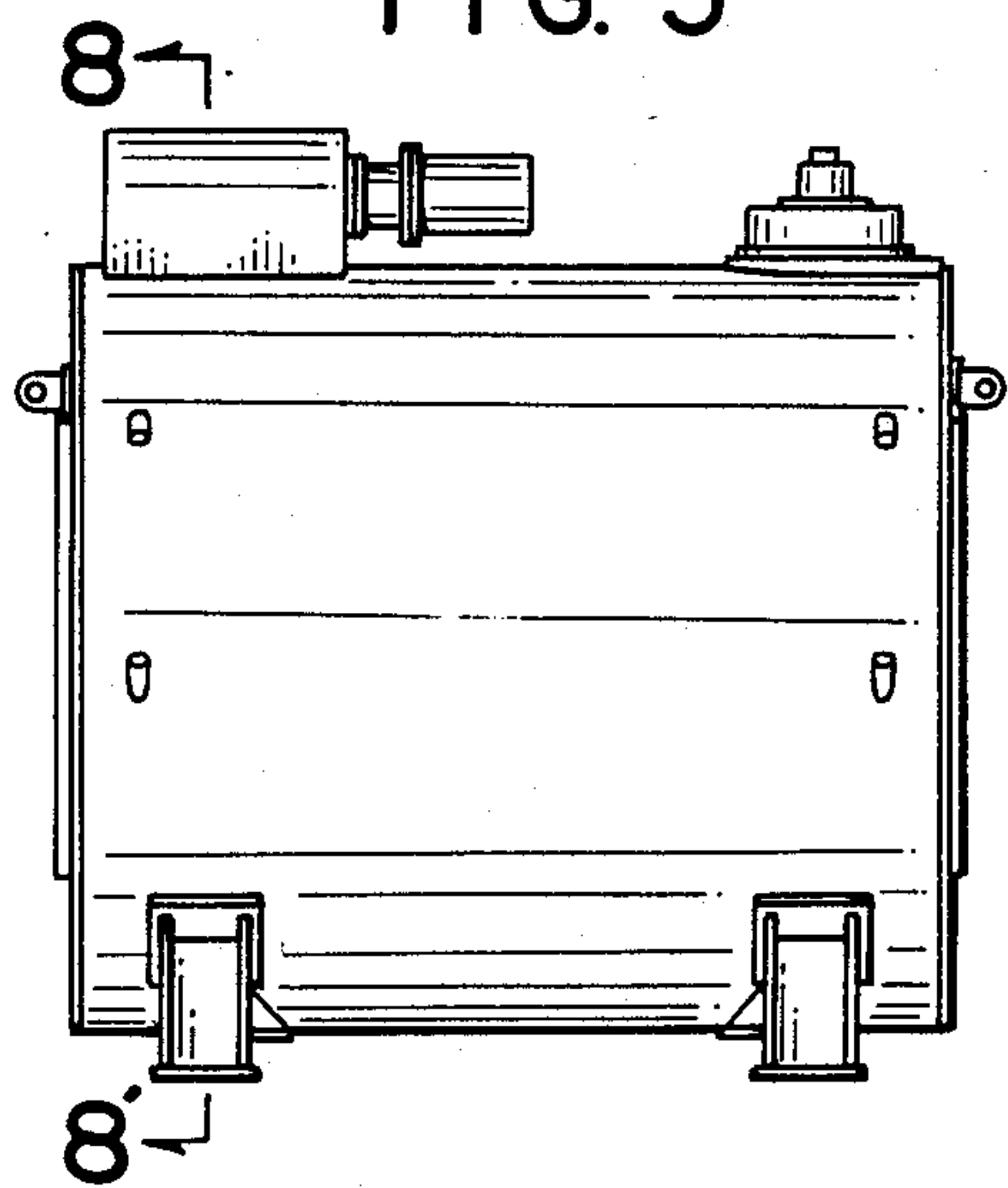

FIG. 6

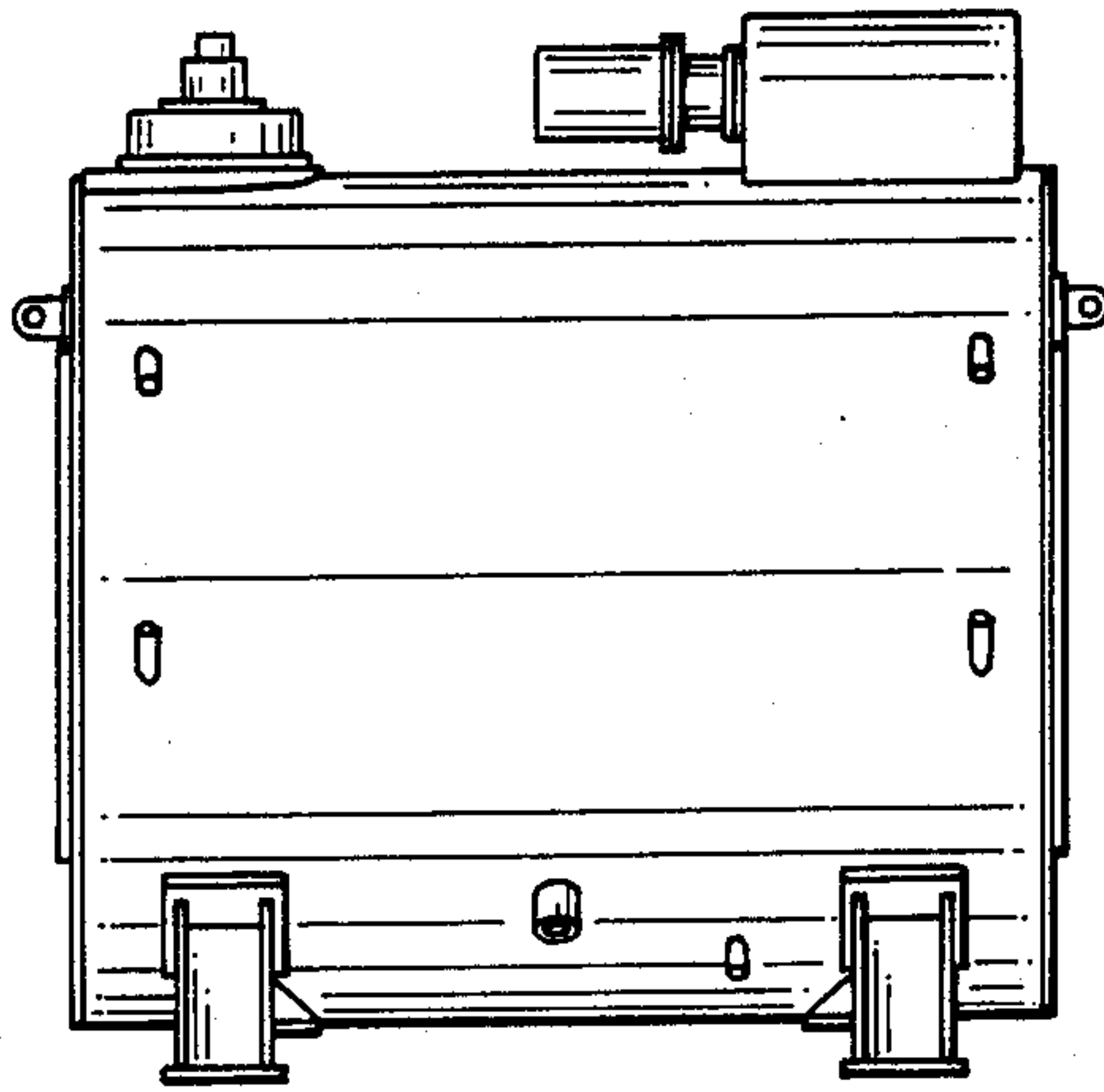

FIG. 7

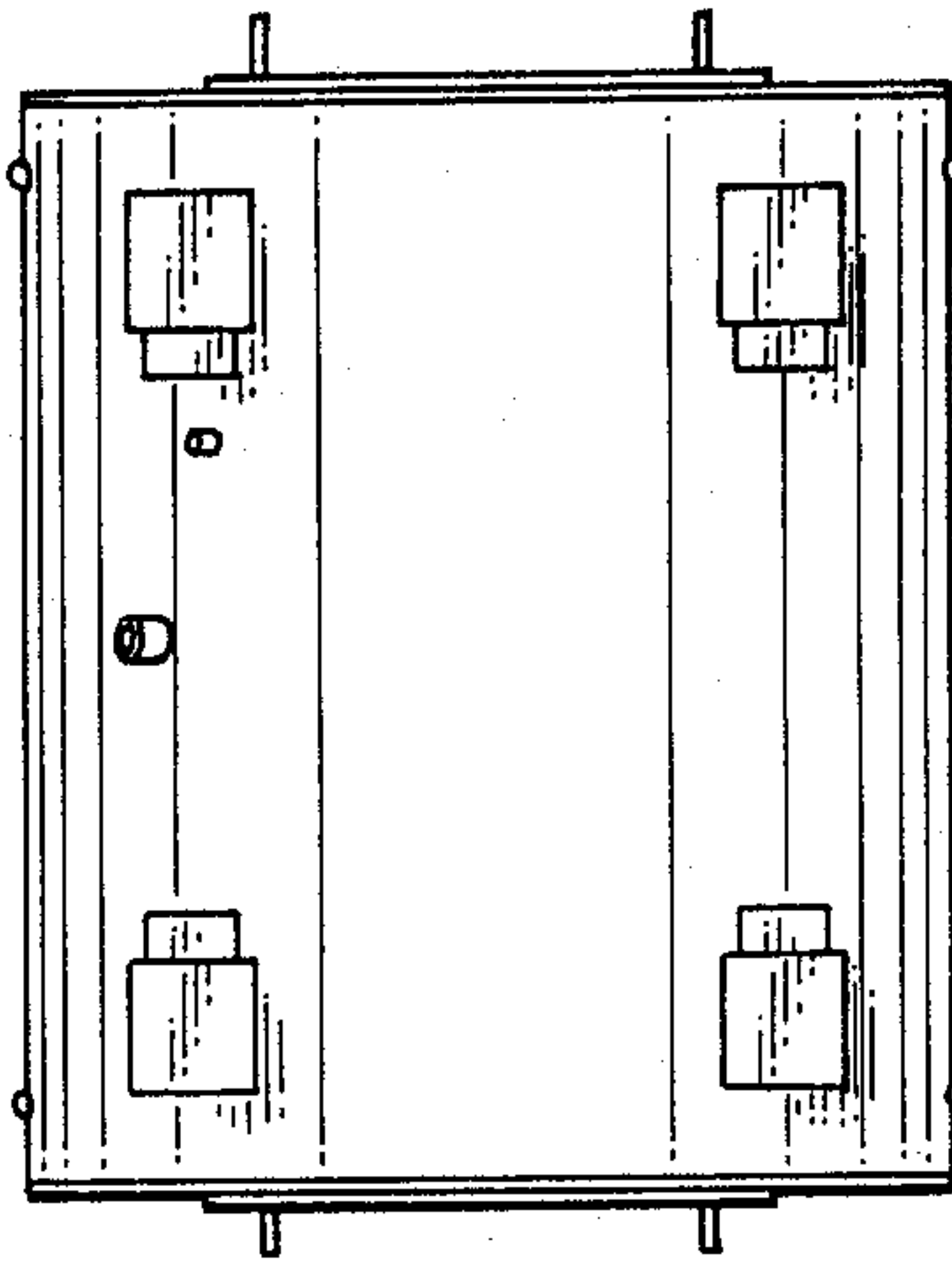

FIG. 8

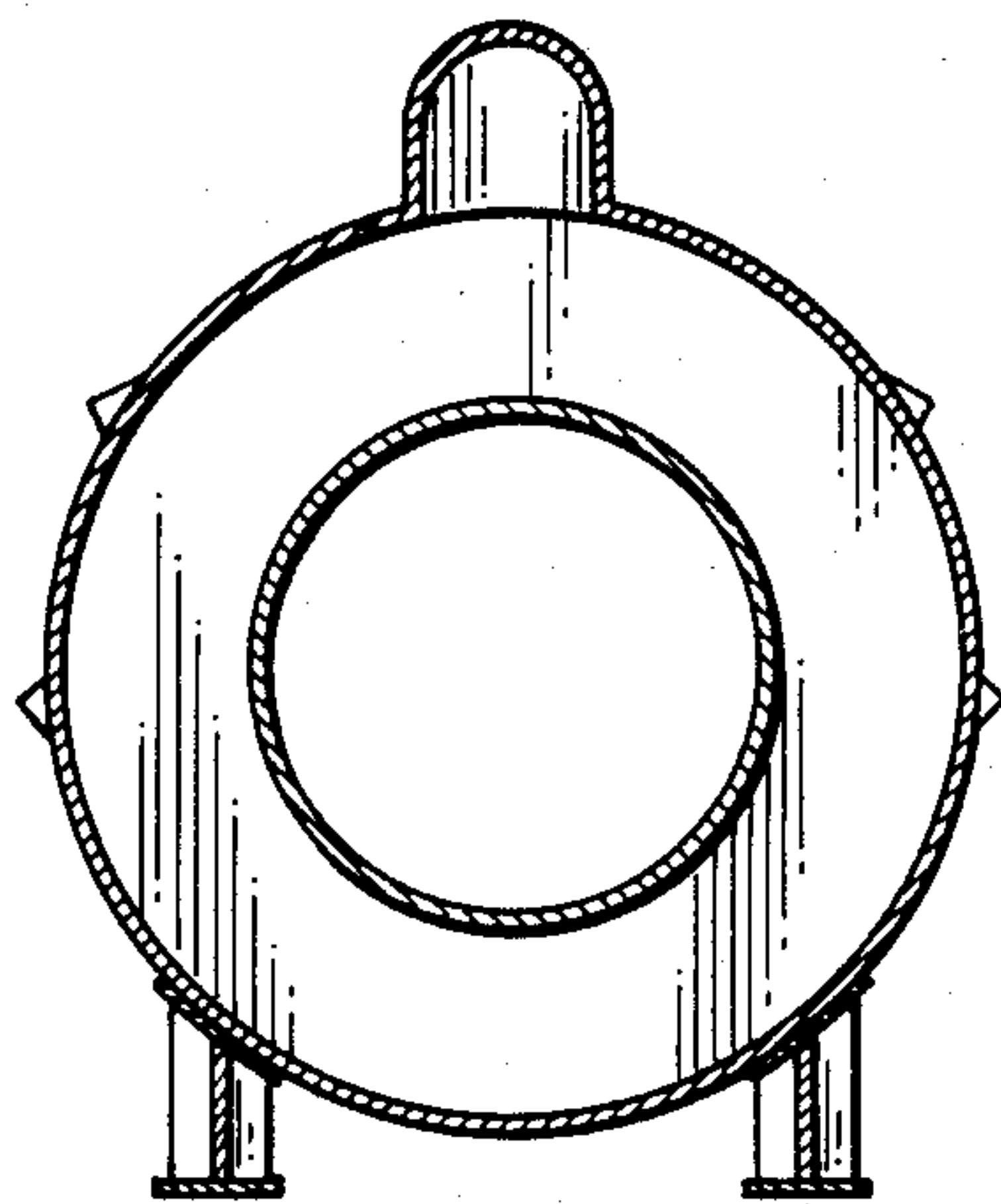

FIG. 9

