

[54] ALL TERRAIN VEHICLE SKI UNIT

[76] Inventor: Steve A. Symington, R1, Box 136D, Reche, N. Dak.

[**] Term: 14 Years

[21] Appl. No.: 128,510

[22] Filed: Dec. 3, 1987

[52] U.S. Cl. D12/7

[58] Field of Search D12/7; 280/21.1, 25; 180/182

3,809,172 5/1974 Hendrickson et al. 280/25
4,424,979 1/1984 Takagi 280/21.1

Primary Examiner—James M. Gandy
Assistant Examiner—Melody Brown
Attorney, Agent, or Firm—Jerry T. Kearns

[57] CLAIM

The ornamental design for an all terrain vehicle ski unit, as shown and described.

DESCRIPTION

FIG. 1 is a front elevational view of an all terrain vehicle ski unit showing my new design;
FIG. 2 is a rear elevational view thereof;
FIG. 3 is a left side elevational view thereof;
FIG. 4 is a right side elevational view thereof;
FIG. 5 is a top plan view thereof; and,
FIG. 6 is a bottom plan view thereof.

[56] References Cited
U.S. PATENT DOCUMENTS

D. 225,106	11/1972	Maijala	D12/7
D. 229,928	1/1974	Lapointe et al.	D12/7
3,623,564	11/1971	Higginbotham	280/25
3,777,831	12/1973	Hale	D12/7

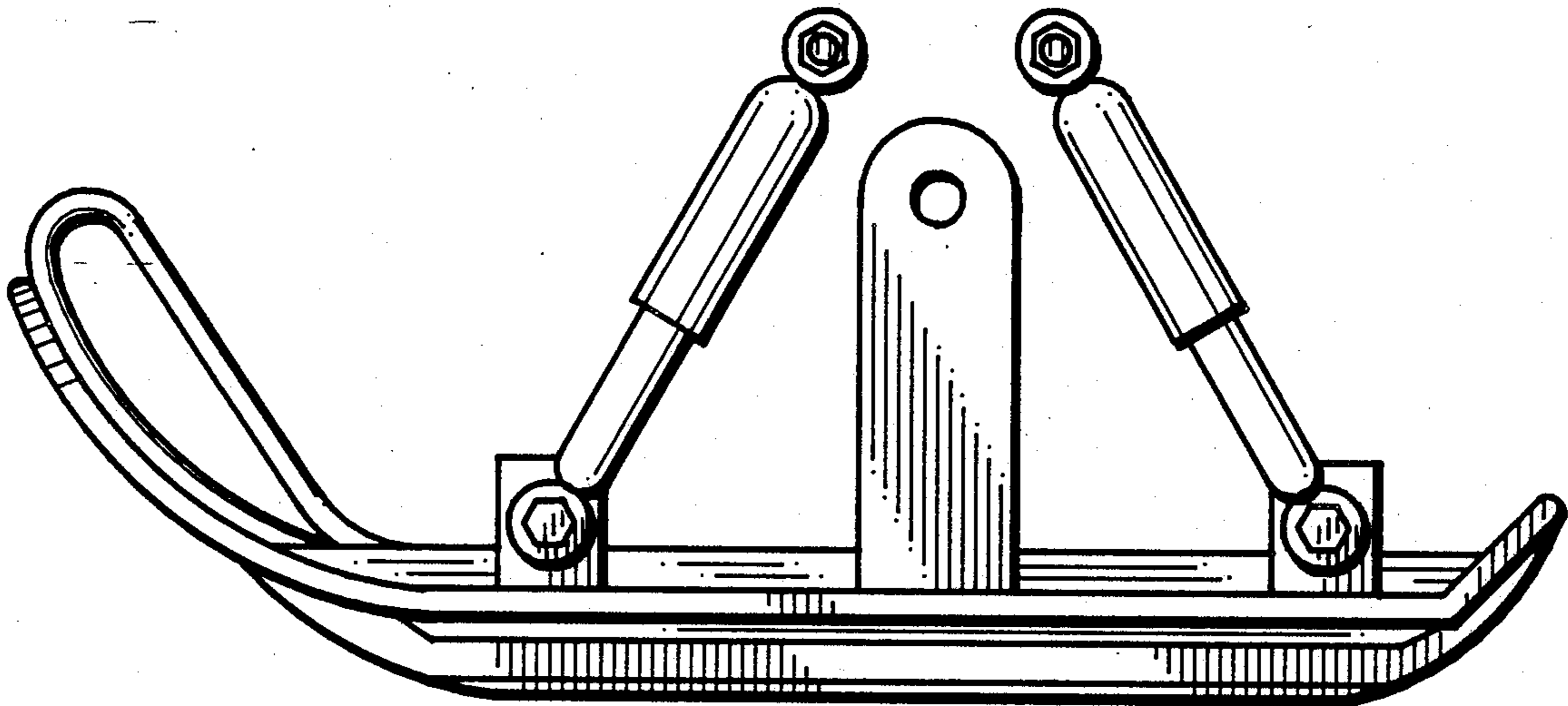

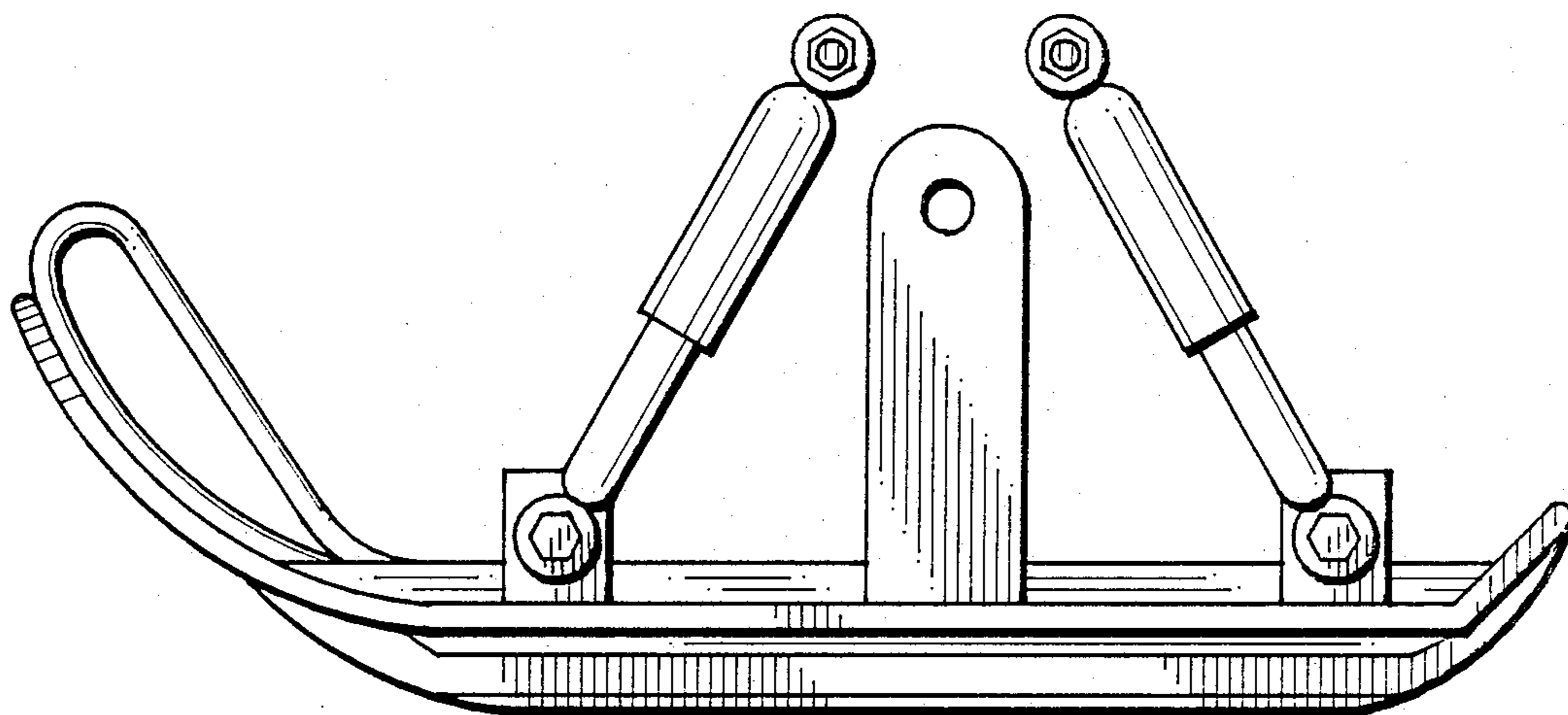

Fig. 1

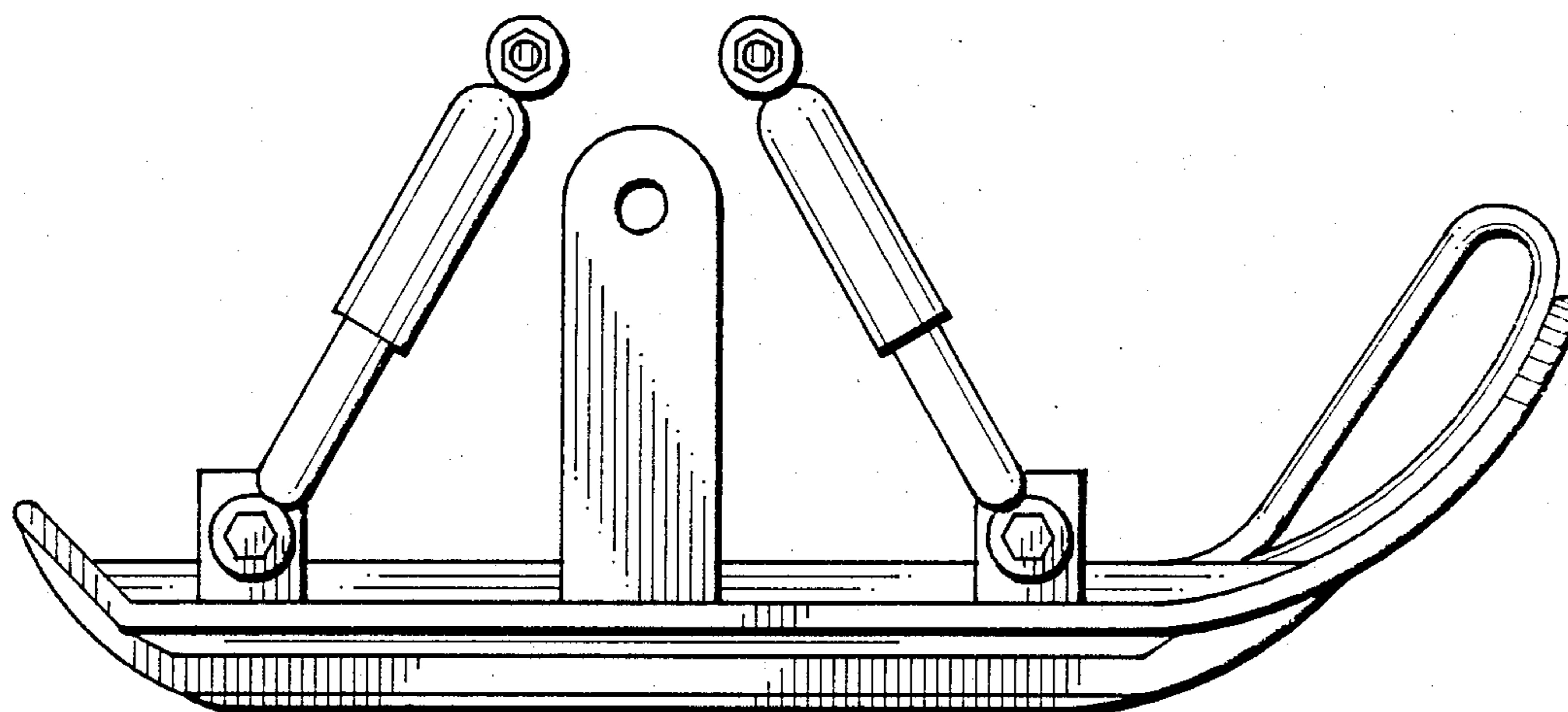

Fig. 2

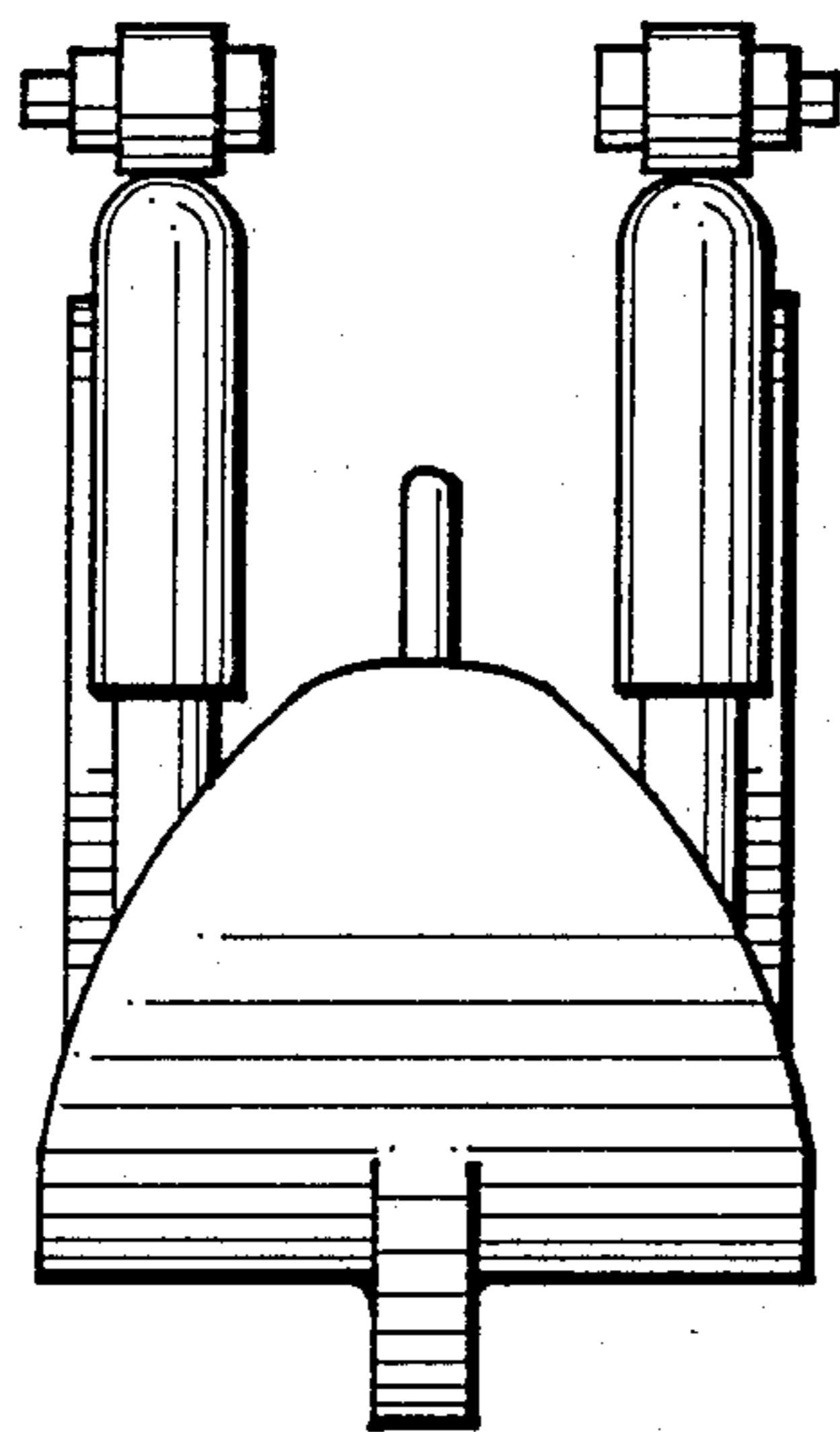

Fig. 3

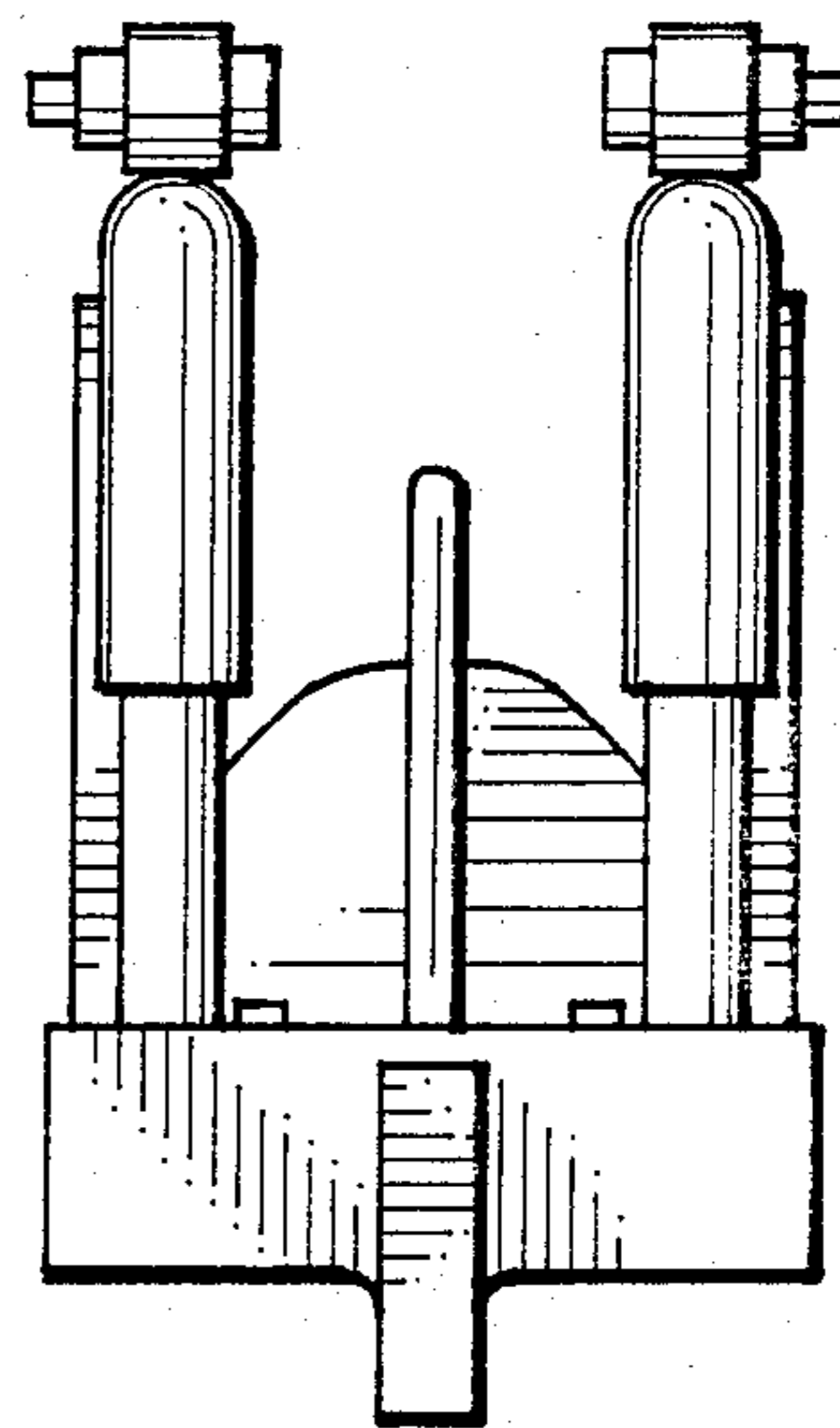

Fig. 4

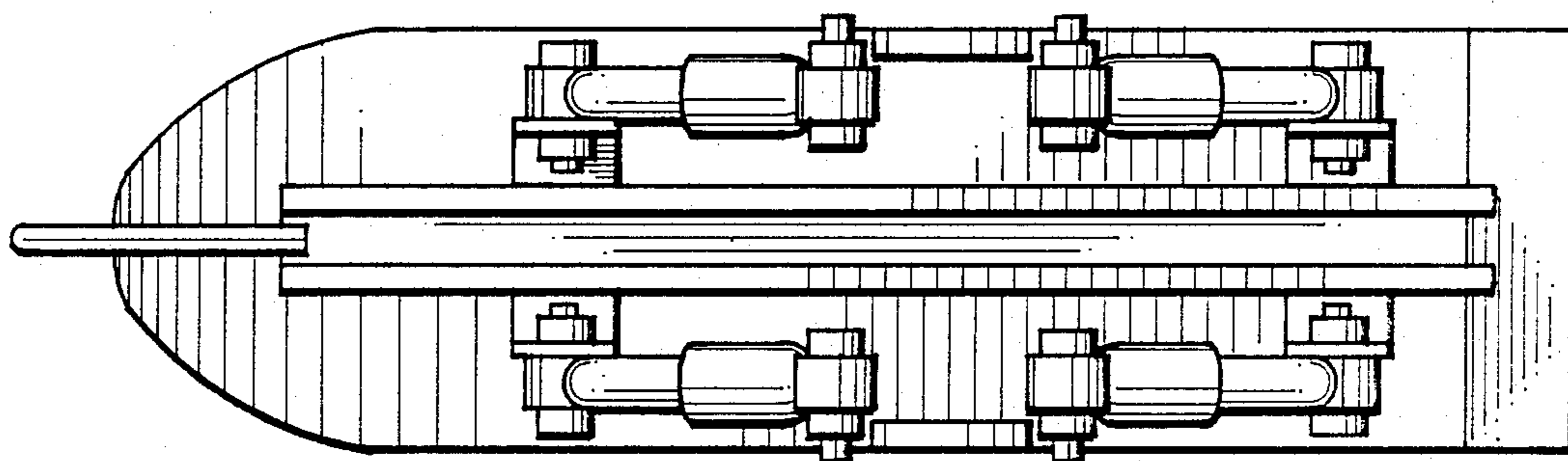

Fig. 5

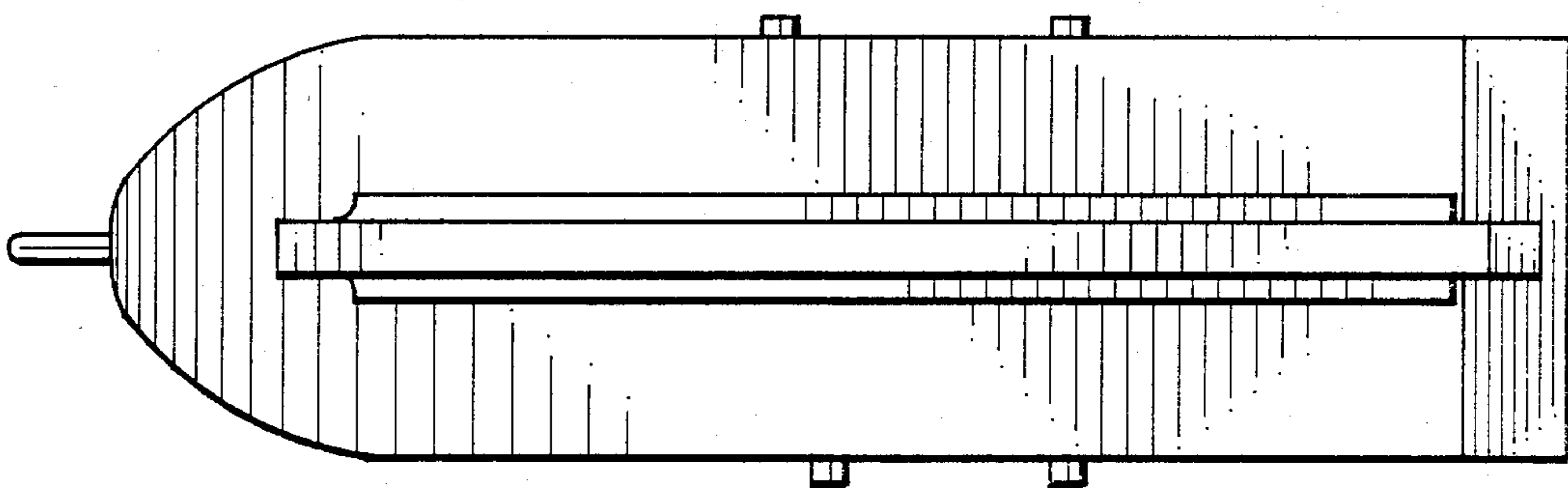

Fig. 6