

[54] **BOAT TRAILER WINCH BRACKET**

[76] **Inventor:** Byron L. Godbersen, Lake LaJure Estates, Ida Grove, Iowa 51445  
[\*\*] **Term:** 14 Years  
[21] **Appl. No.:** 113,196  
[22] **Filed:** Oct. 26, 1987  
[52] **U.S. Cl. ....** D12/106  
[58] **Field of Search ....** D12/106, 101; D8/349, D8/354, 373; 414/529-536; 280/414.1

[56] **References Cited**

**U.S. PATENT DOCUMENTS**

3,540,606 11/1970 Johnson ..... 414/531  
3,547,285 12/1970 Plummer ..... 414/534  
3,584,753 6/1971 Voeller ..... 414/534  
3,717,268 2/1973 Snodgrass ..... D12/101  
4,519,738 5/1985 Wood ..... 280/414.1  
4,687,219 8/1987 Rendzio ..... 280/414.1

**FOREIGN PATENT DOCUMENTS**

0666092 7/1963 Canada ..... 280/414.1

**OTHER PUBLICATIONS**

E.Z. Loader Magazine, Sep. 86, p. 17, Winch Bracket on a Sprint Boat Trailer.

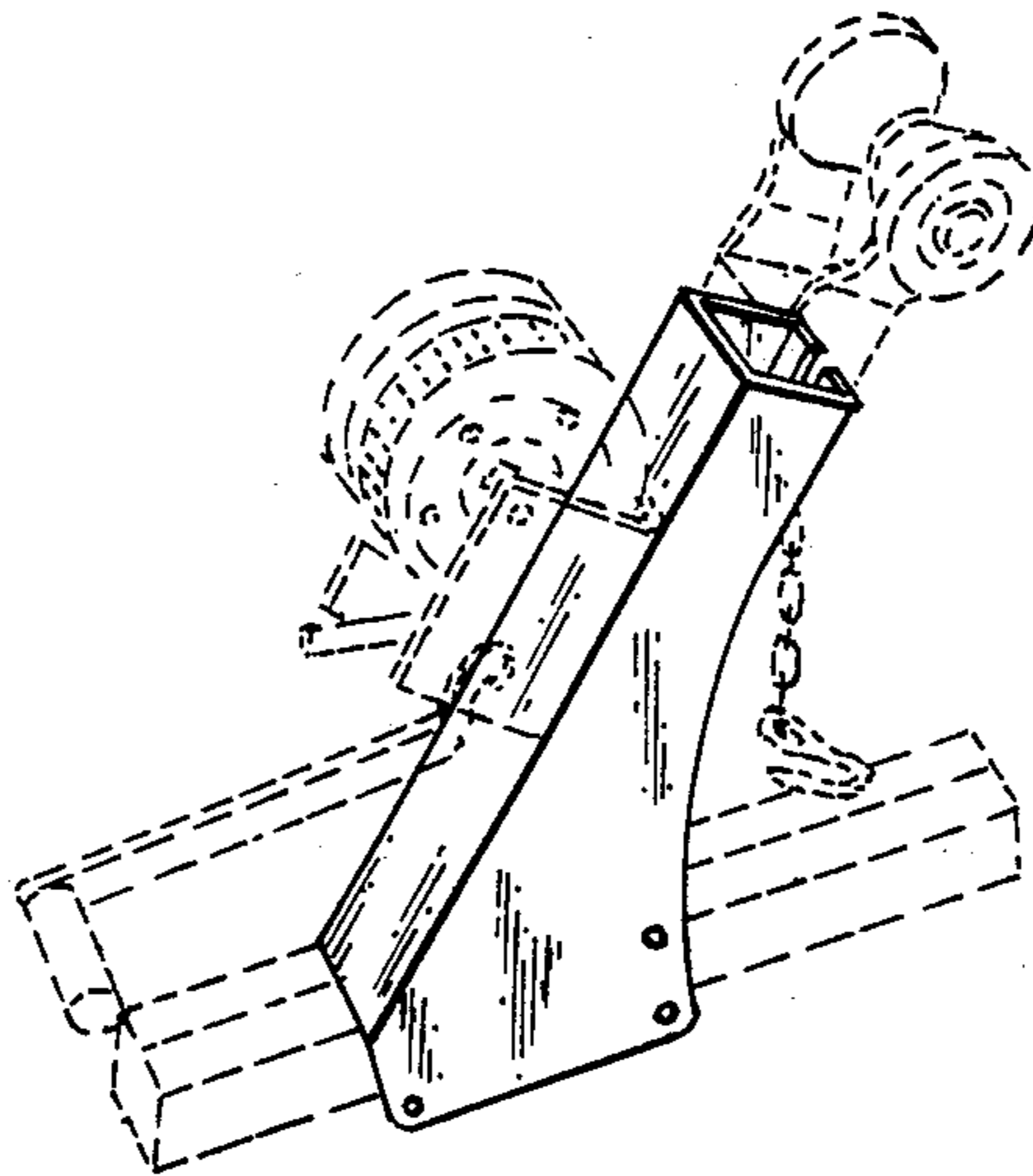
*Primary Examiner*—James M. Gandy  
*Assistant Examiner*—Melody Brown  
*Attorney, Agent, or Firm*—Henderson & Sturm

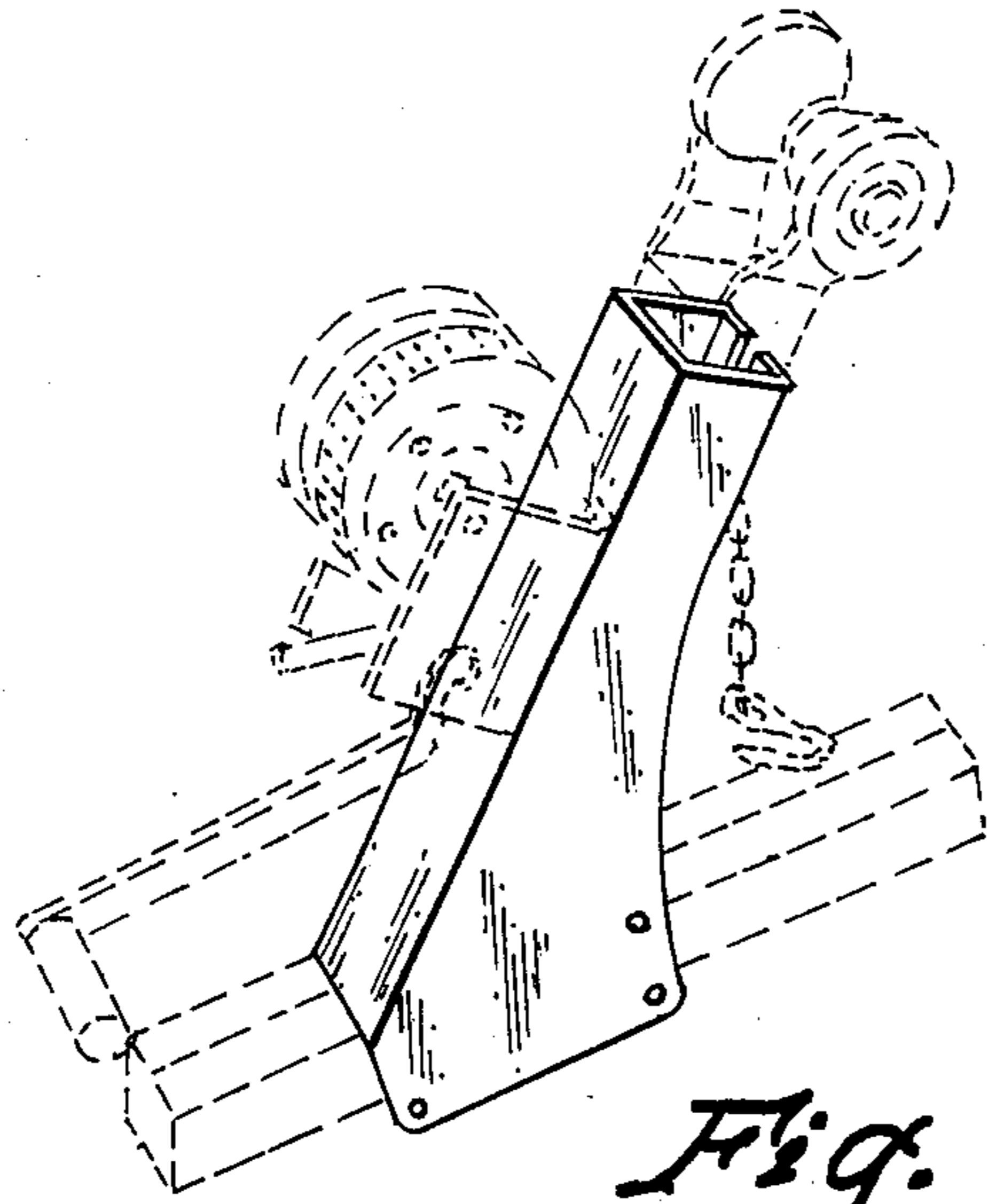
[57] **CLAIM**

The ornamental design for a boat trailer winch bracket, as shown and described.

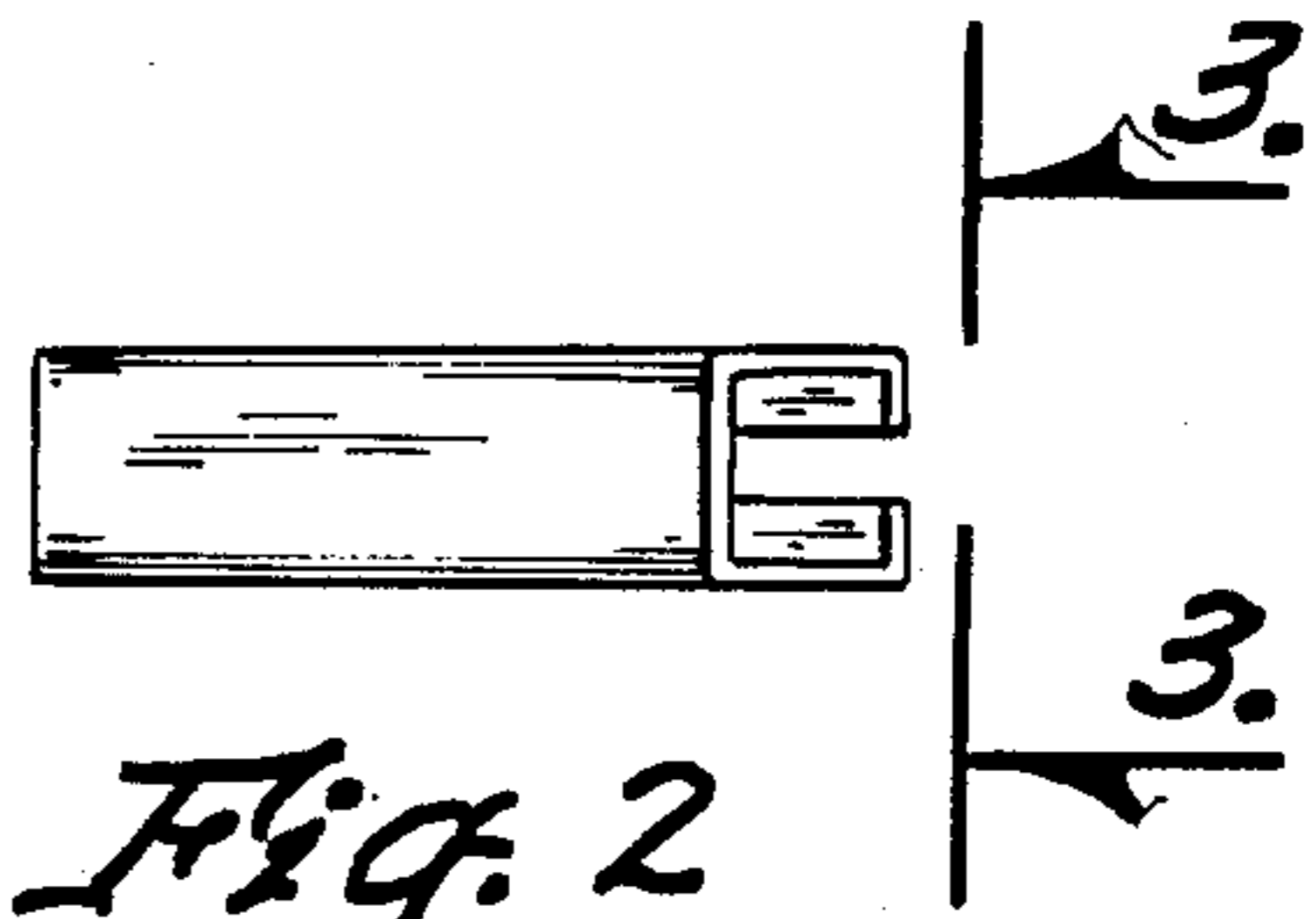
**DESCRIPTION**

FIG. 1 is a perspective view of a boat trailer winch bracket showing my new design, it being understood that the broken lines are for illustrative purposes only and form no part of the claimed design;  
FIG. 2 is a top plan view thereof;  
FIG. 3 is a front elevation view taken along line 3—3 of FIG. 2;  
FIG. 4 is a side elevation view thereof, the opposite side being a mirror image of that shown;  
FIG. 5 is a rear elevation view thereof; and  
FIG. 6 is a bottom plan view thereof.

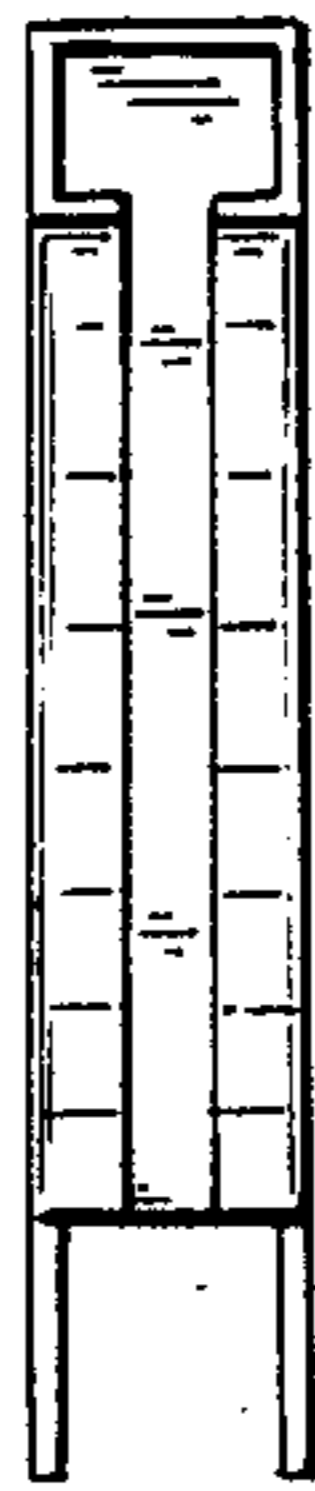




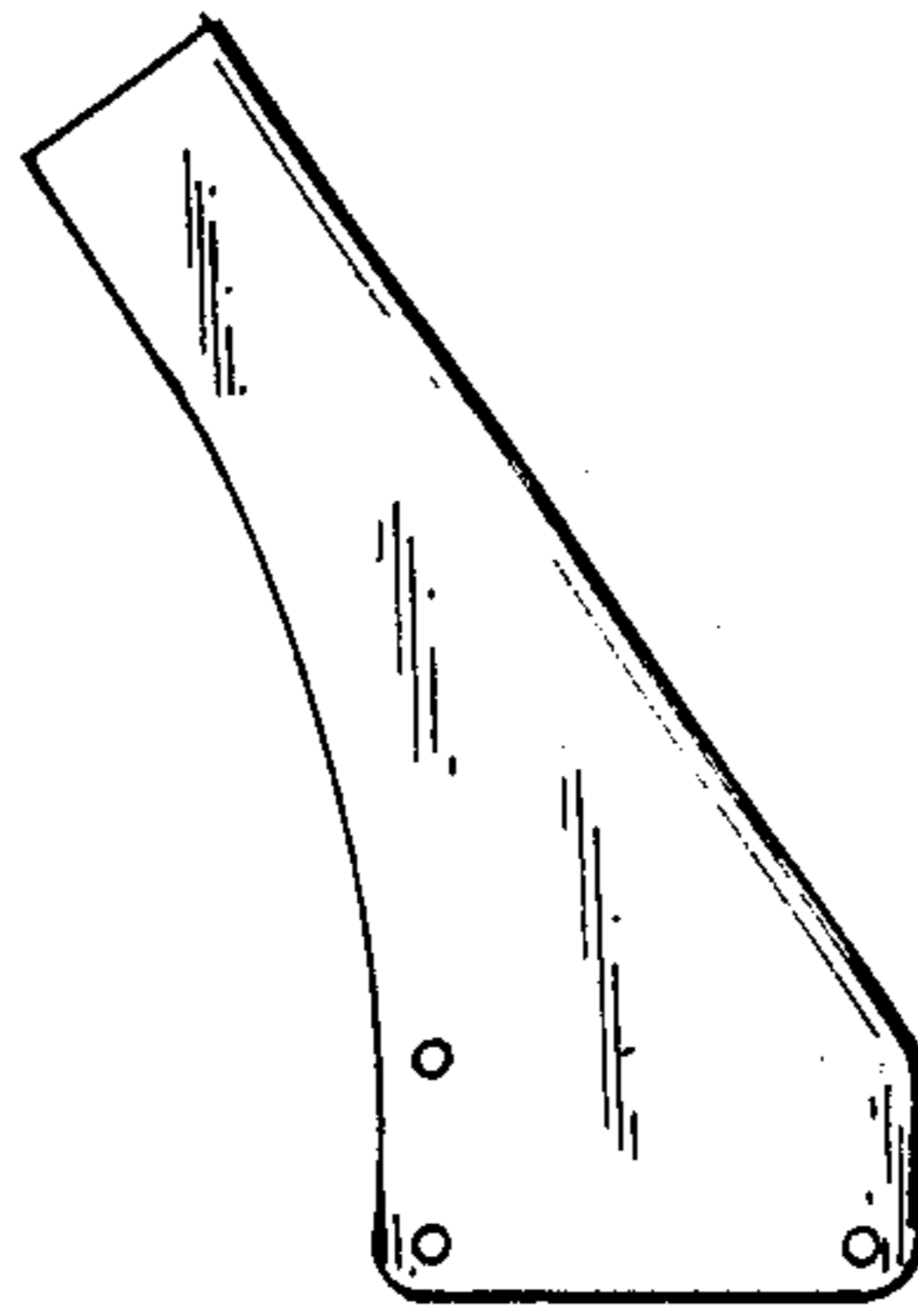
*Fig. 1*



*Fig. 2*



*Fig. 3*



*Fig. 4*



*Fig. 5*



*Fig. 6*