

United States Patent [19]

Brushaber

[11] Patent Number: **Des. 306,396**

[45] Date of Patent: **** Mar. 6, 1990**

[54] **ADJUSTABLE MOORING BRACKET**

[76] Inventor: **Donald Brushaber, 221 Hayes Ct., Normandy Beach, N.J. 08739**

[**] Term: **14 Years**

[21] Appl. No.: **22,364**

[22] Filed: **Mar. 5, 1987**

[52] U.S. Cl. **D8/355; D8/354; D12/317; 348/538; 114/230; 114/364**

[58] Field of Search **D8/354, 356, 355; D11/182, 166; 248/291, 40, 538, 343; 114/230, 364, 219; D12/317**

[56] **References Cited**

U.S. PATENT DOCUMENTS

D. 35,028	9/1901	Ricker	D8/356
D. 177,955	6/1956	Arbogast	D8/355
D. 201,694	7/1965	Spindler	D8/355
D. 229,480	12/1973	Brushaber	D8/355
D. 249,458	9/1978	Olsen	D8/354
661,643	11/1900	Mowry	D11/182 X
2,292,523	8/1942	Hynek	D11/166 X
3,063,668	11/1962	Yoke	248/538 X
3,120,831	2/1964	Fulton	114/230
3,144,232	11/1964	Smootz	D8/355 X
3,890,916	6/1975	Tümmers et al.	114/219
4,148,107	4/1979	Karl et al.	114/230 X

4,193,368	3/1980	DeGraaf	114/230
4,438,582	3/1984	Lummis	248/538 X
4,586,688	5/1986	Hartman et al.	248/538
4,676,181	6/1987	Oates, Jr.	114/364 X
4,697,538	10/1987	Day	114/343 X
4,739,575	4/1988	Behrle	248/538 X
4,807,935	2/1989	King	248/291
4,823,723	4/1989	Brooks	114/364 X

FOREIGN PATENT DOCUMENTS

152129 4/1932 Switzerland 114/364

Primary Examiner—Horace B. Fay, Jr.
Attorney, Agent, or Firm—Samuelson & Jacob

[57] **CLAIM**

The ornamental design for an adjustable mooring bracket, as shown.

DESCRIPTION

FIG. 1 is a front elevational view of an adjustable mooring bracket embodying my new design; FIG. 2 is a rear elevational view thereof; FIG. 3 is a side elevational view thereof as viewed from the left of FIG. 1; FIG. 4 is a side elevational view thereof as viewed from the right of FIG. 1; FIG. 5 is a top plan view thereof; and FIG. 6 is a bottom plan view thereof.

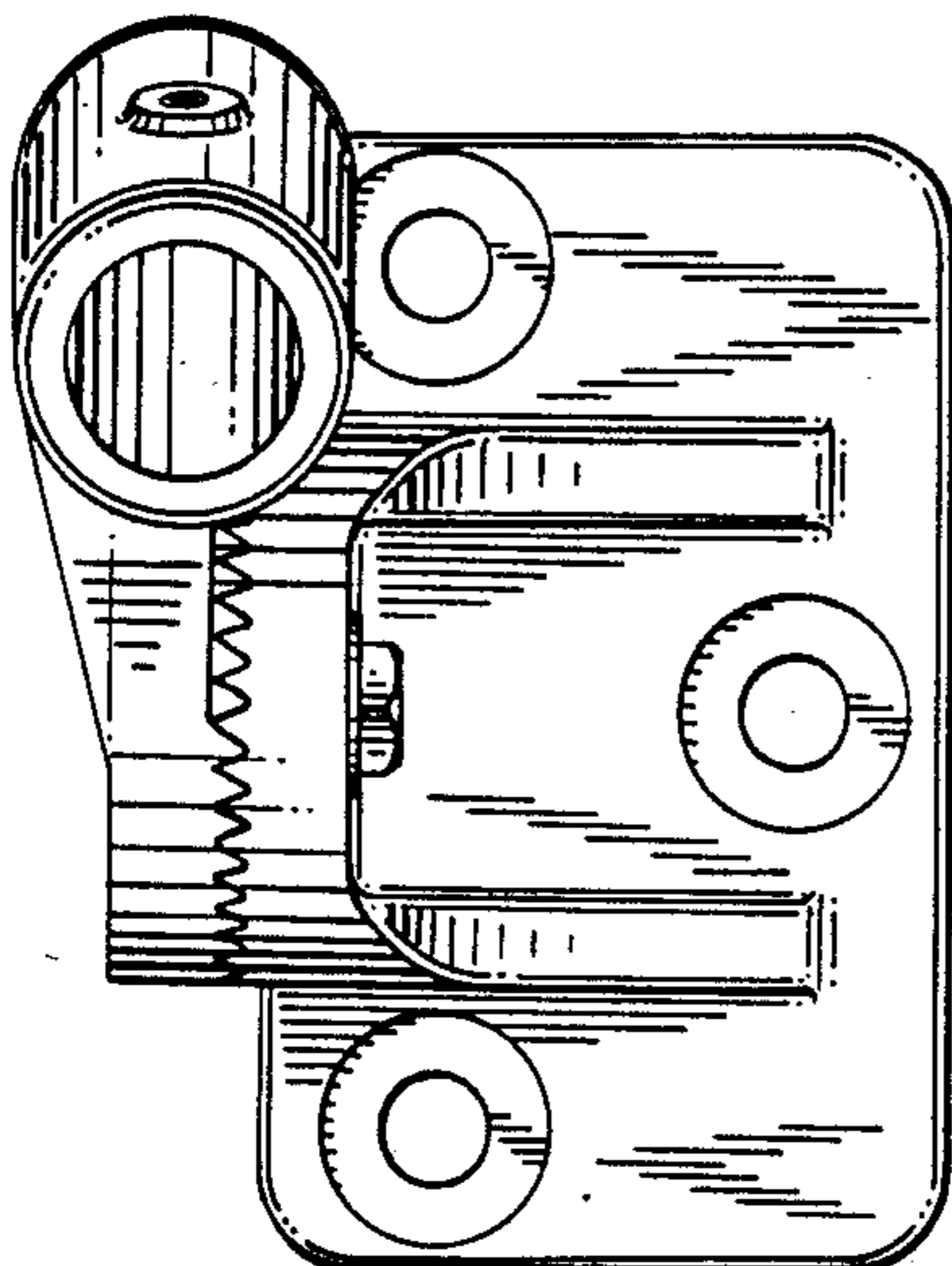
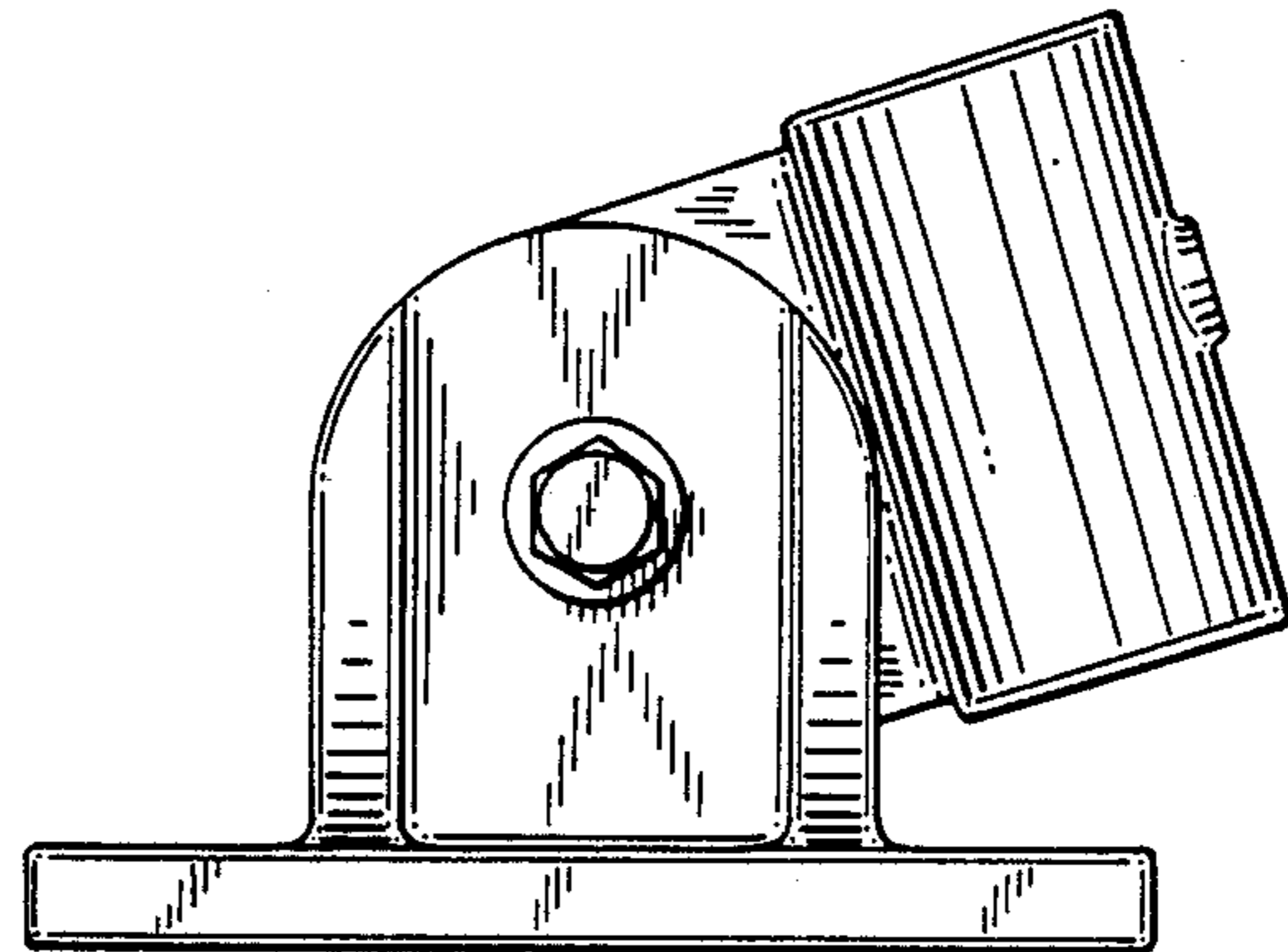

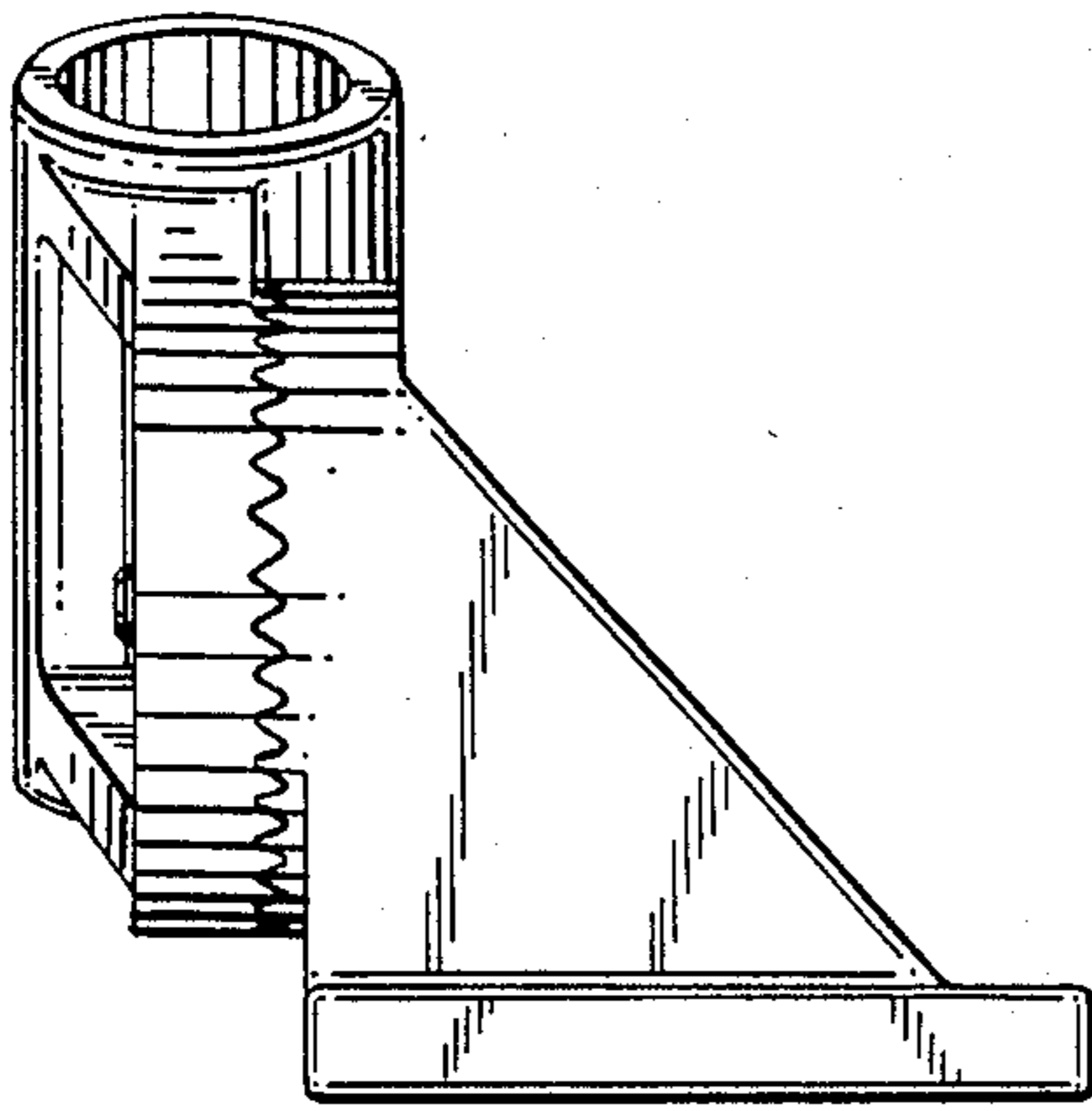

FIG. 1

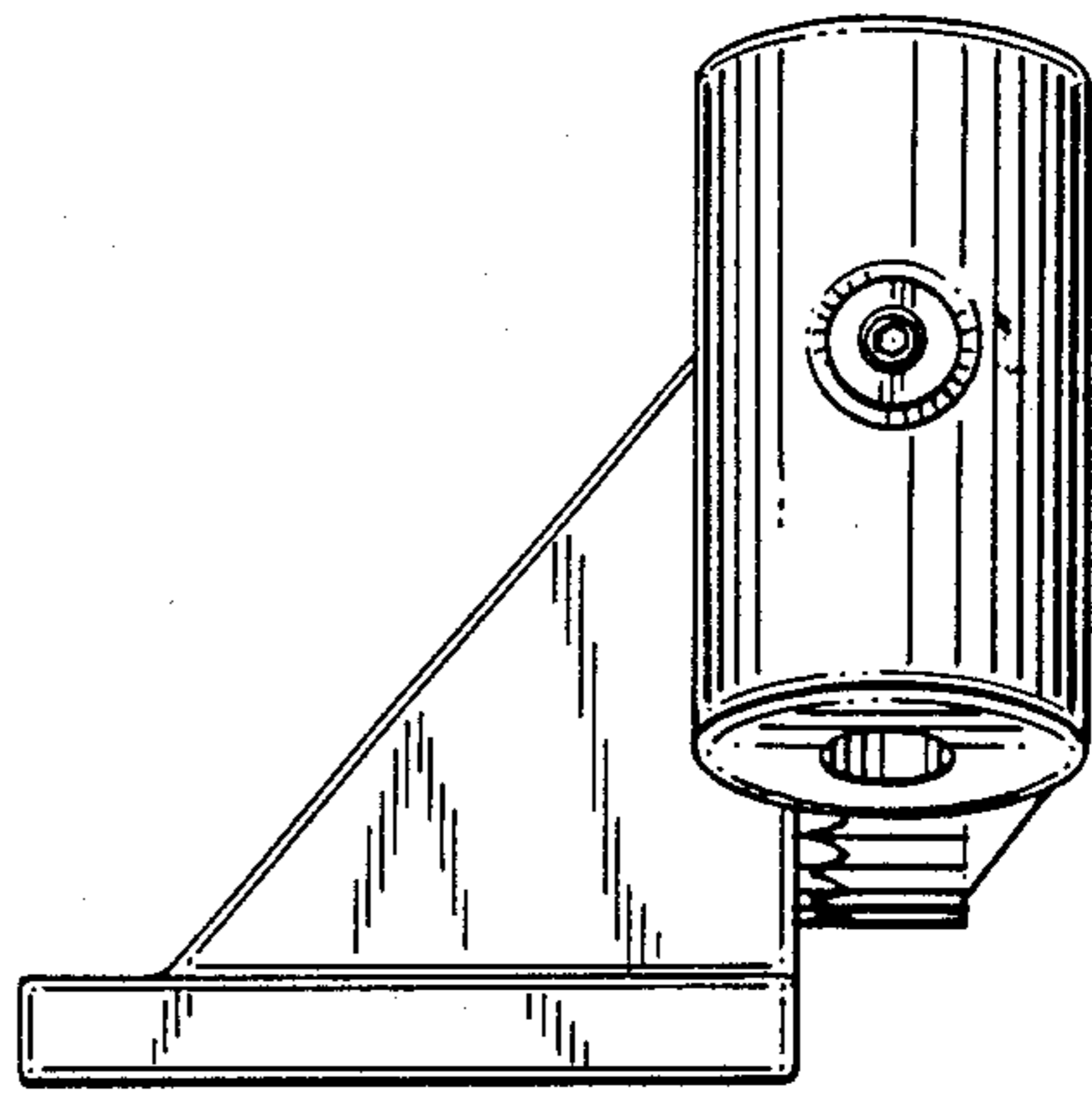

FIG. 2

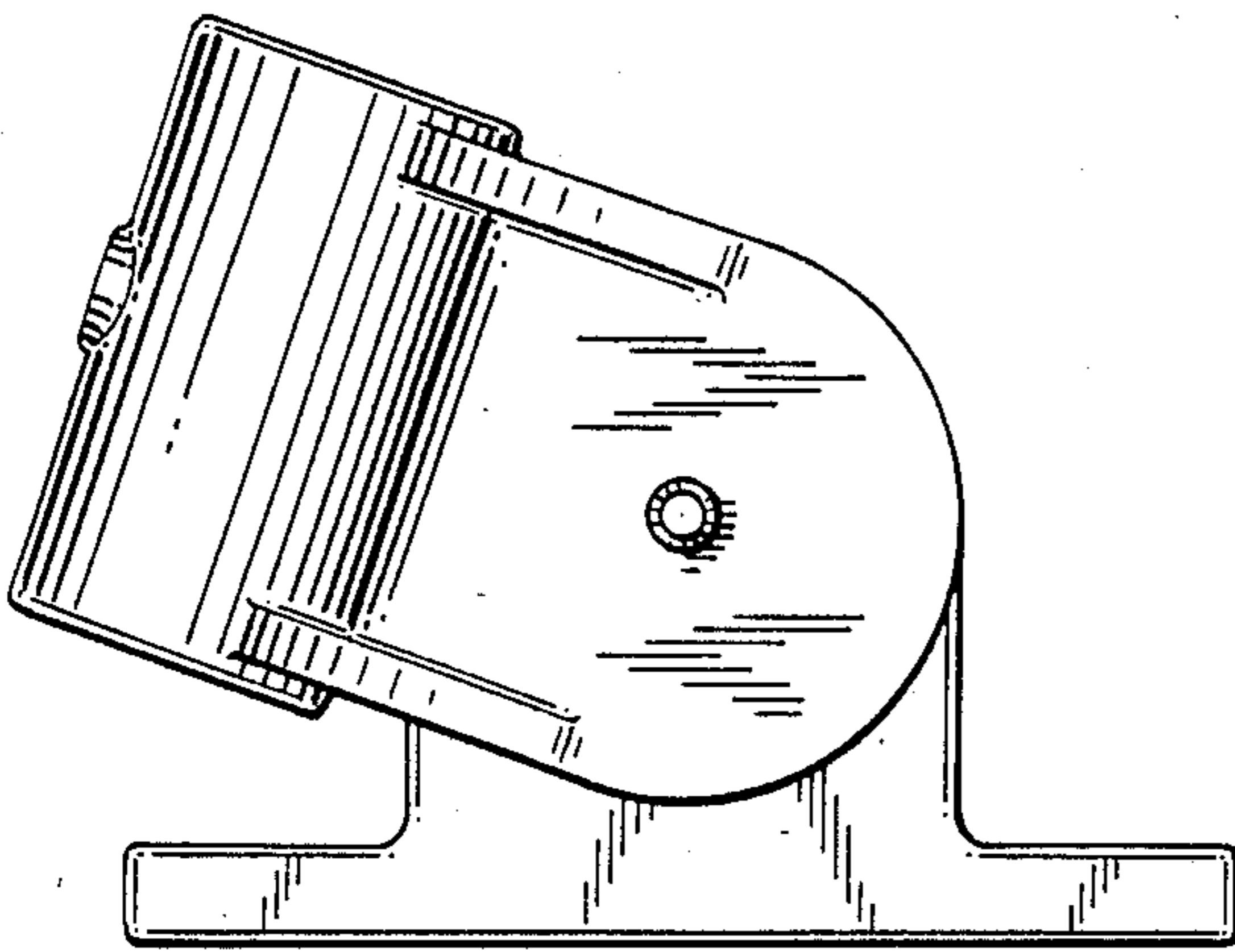

FIG. 3

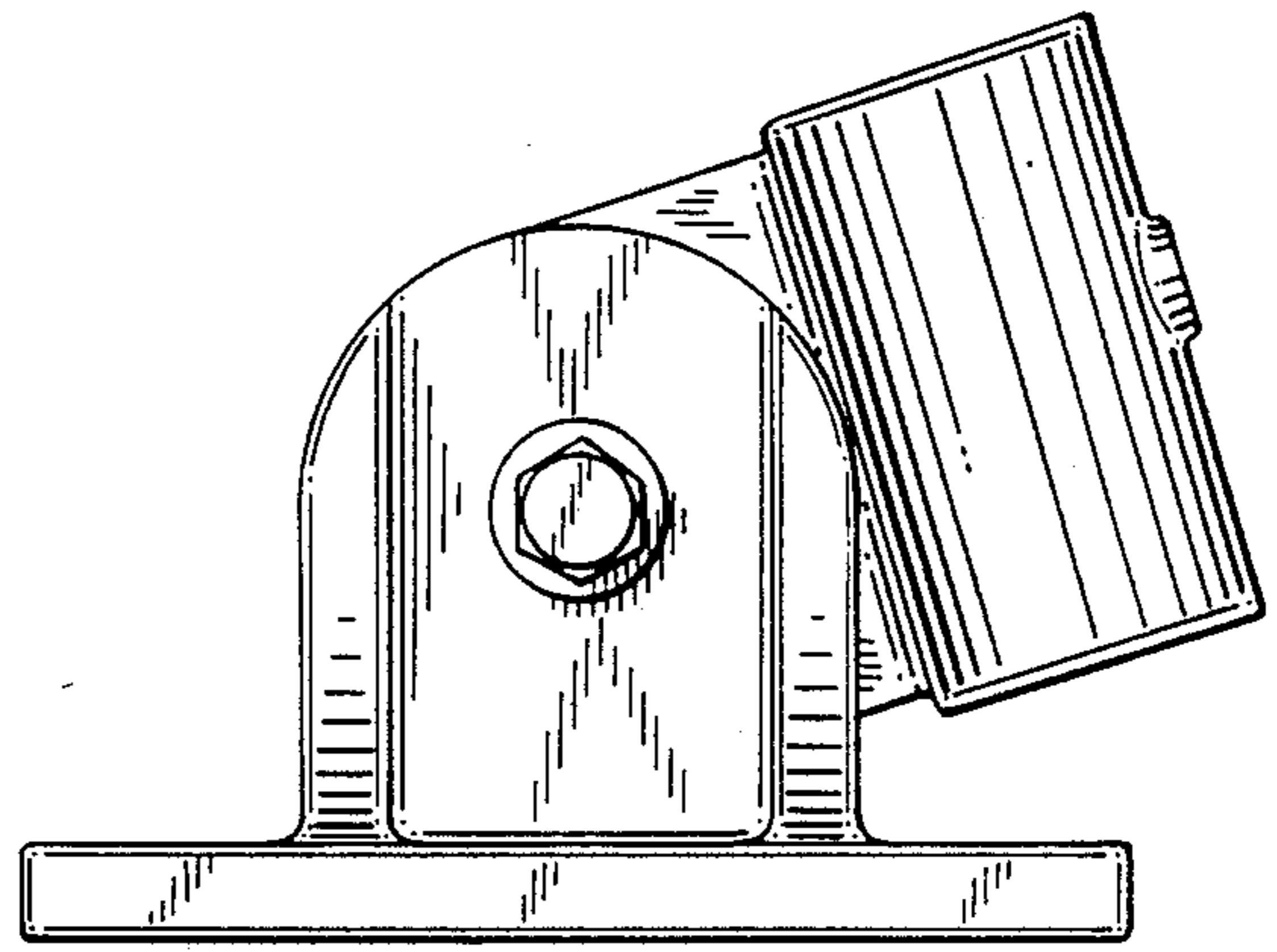

FIG. 4

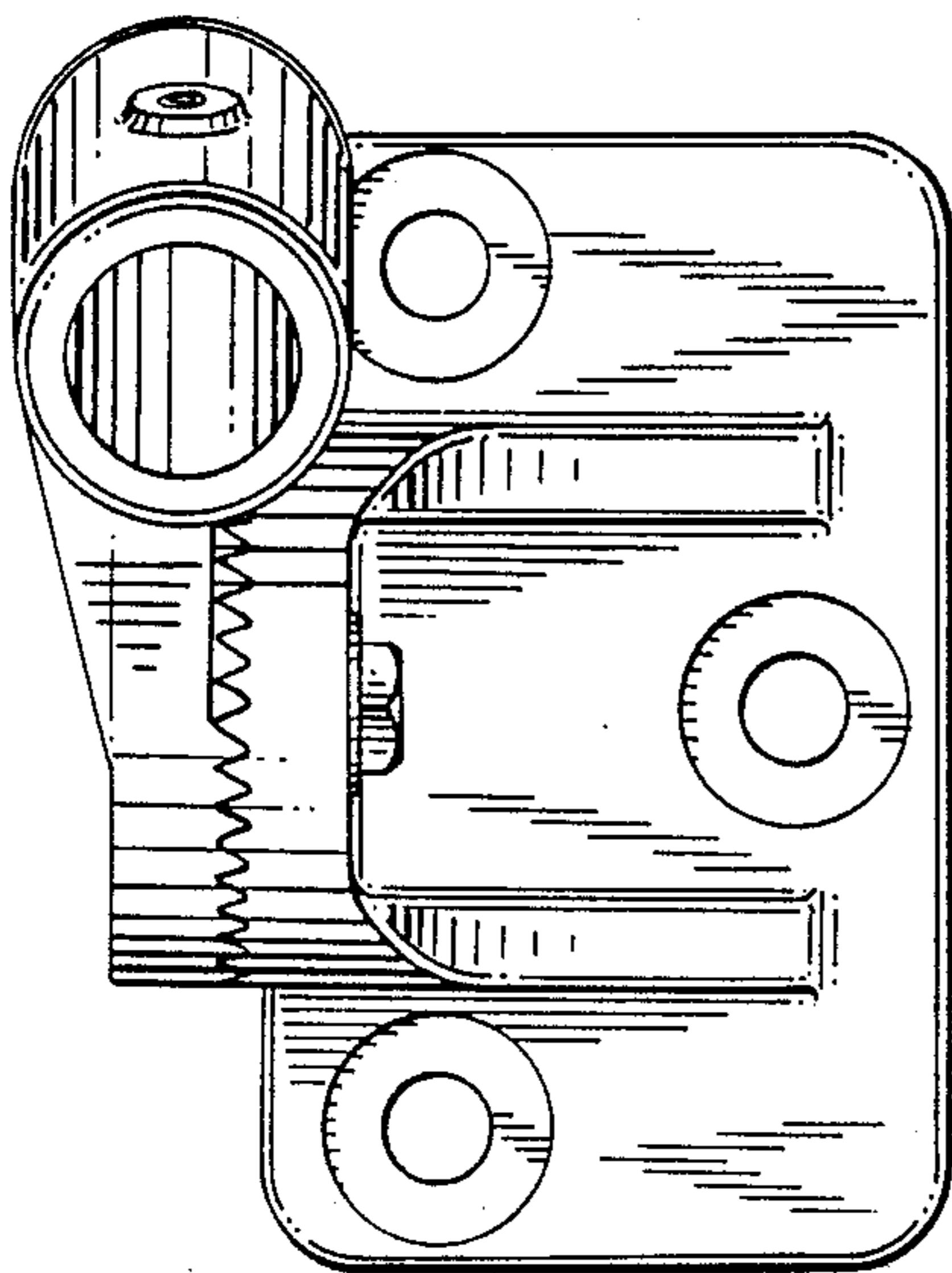

FIG. 5

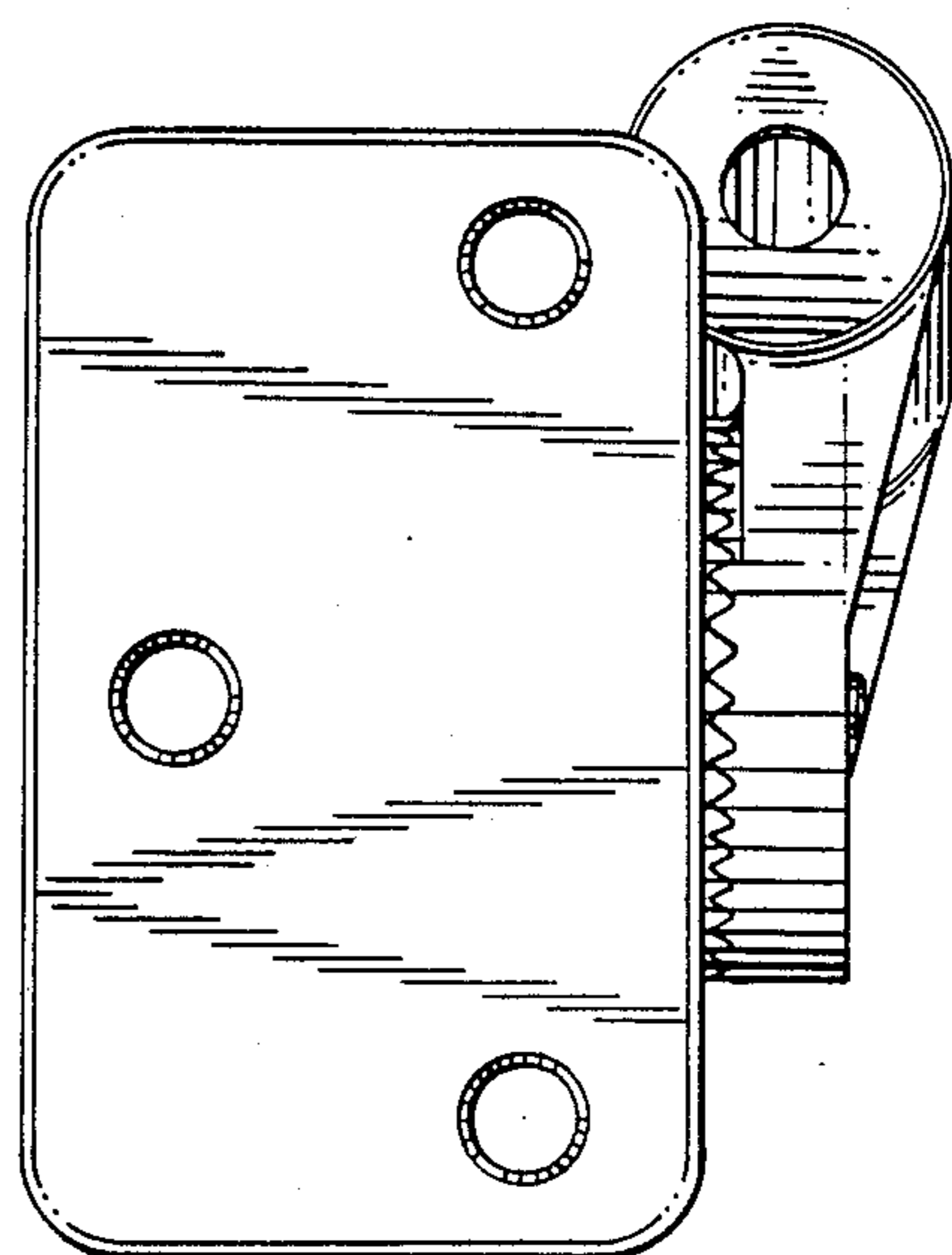

FIG. 6