

[54] **AUTOMOBILE**

[75] **Inventor:** Leonardo Fioravanti, Moncalieri, Italy

[73] **Assignee:** Ferrari Societa per Azioni Esercizio Fabbriche Automobili e Corse, Modena, Italy

[**] **Term:** 14 Years

[21] **Appl. No.:** 132,541

[22] **Filed:** Dec. 11, 1987

[30] **Foreign Application Priority Data**

Jun. 12, 1987 [IT] Italy 53403/87[U]
[52] **U.S. Cl.** D12/91
[58] **Field of Search** D12/90, 91, 92;
D21/136; 296/185

[56] **References Cited**
PUBLICATIONS

Road & Track, 8/84, pp. 46 & 47, Ferrari GTO.

Road & Track, 8/86, p. 38, Rear End of Ferrari Mondial, lower right side of page.
Motor Trend, 1/86, p. 17, DeLorean Firestar 500, top of page.
Road & Track, 4/87, p. 41, Ferrari GTO Automobile, center of page.
Motor Trend, 1/86, p. 25, Porsche Automobile, bottom right side of page.
Road & Track, 3/85, p. 43, Porsche 959, top & bottom of page.

Primary Examiner—James M. Gandy
Attorney, Agent, or Firm—Sughrue, Mion, Zinn, Macpeak & Seas

[57] **CLAIM**

The ornamental design for an automobile, as shown.

DESCRIPTION

FIG. 1 is a side elevational view of an automobile showing my new design;
FIG. 2 is an enlarged front elevational view thereof;
FIG. 3 is an enlarged rear elevational view thereof;
FIG. 4 is a front perspective view thereof;
FIG. 5 is a rear perspective view thereof; and
FIG. 6 is a top plan view thereof.

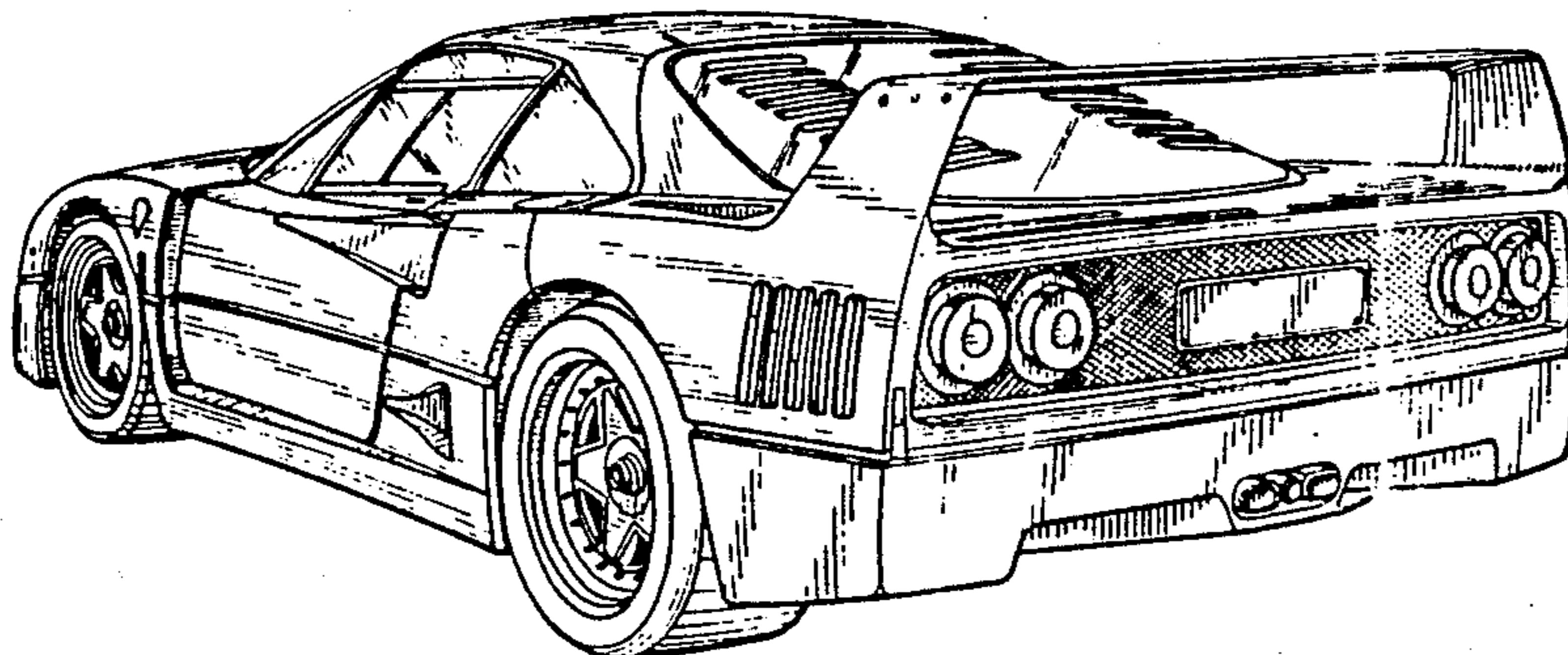
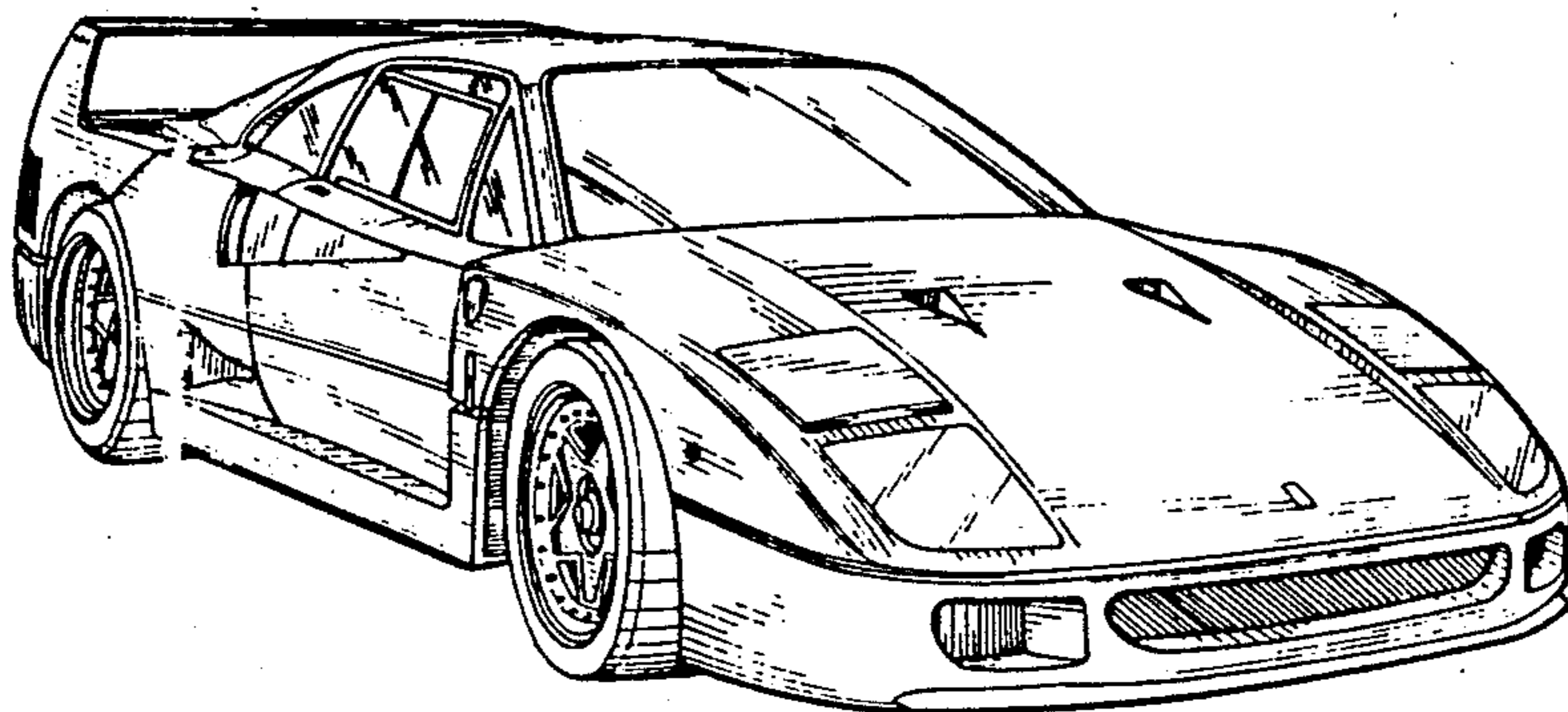

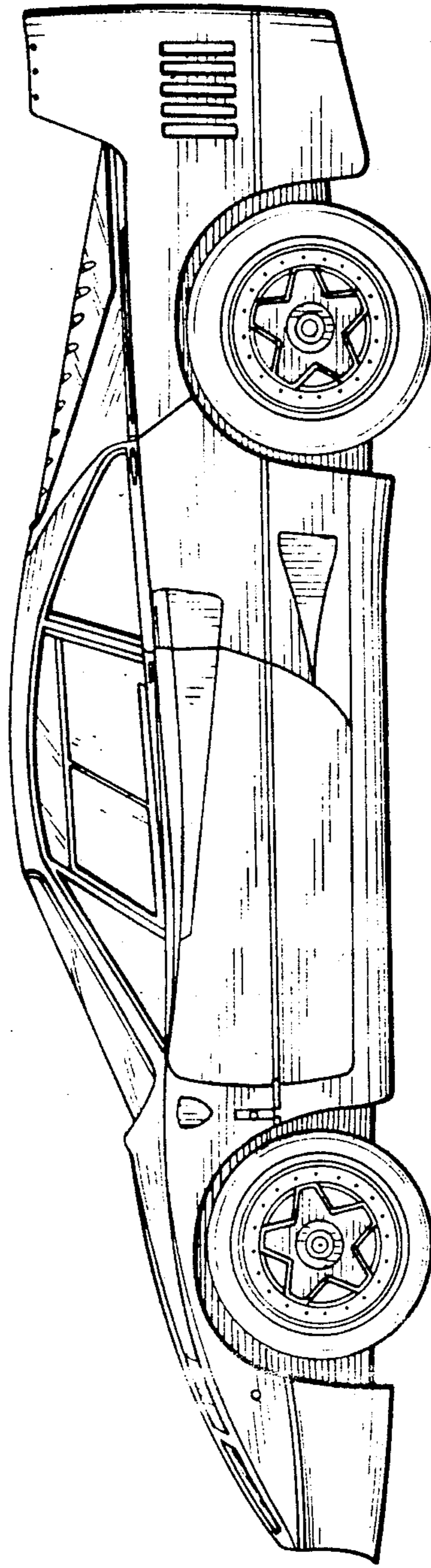

FIG. 1

FIG. 2

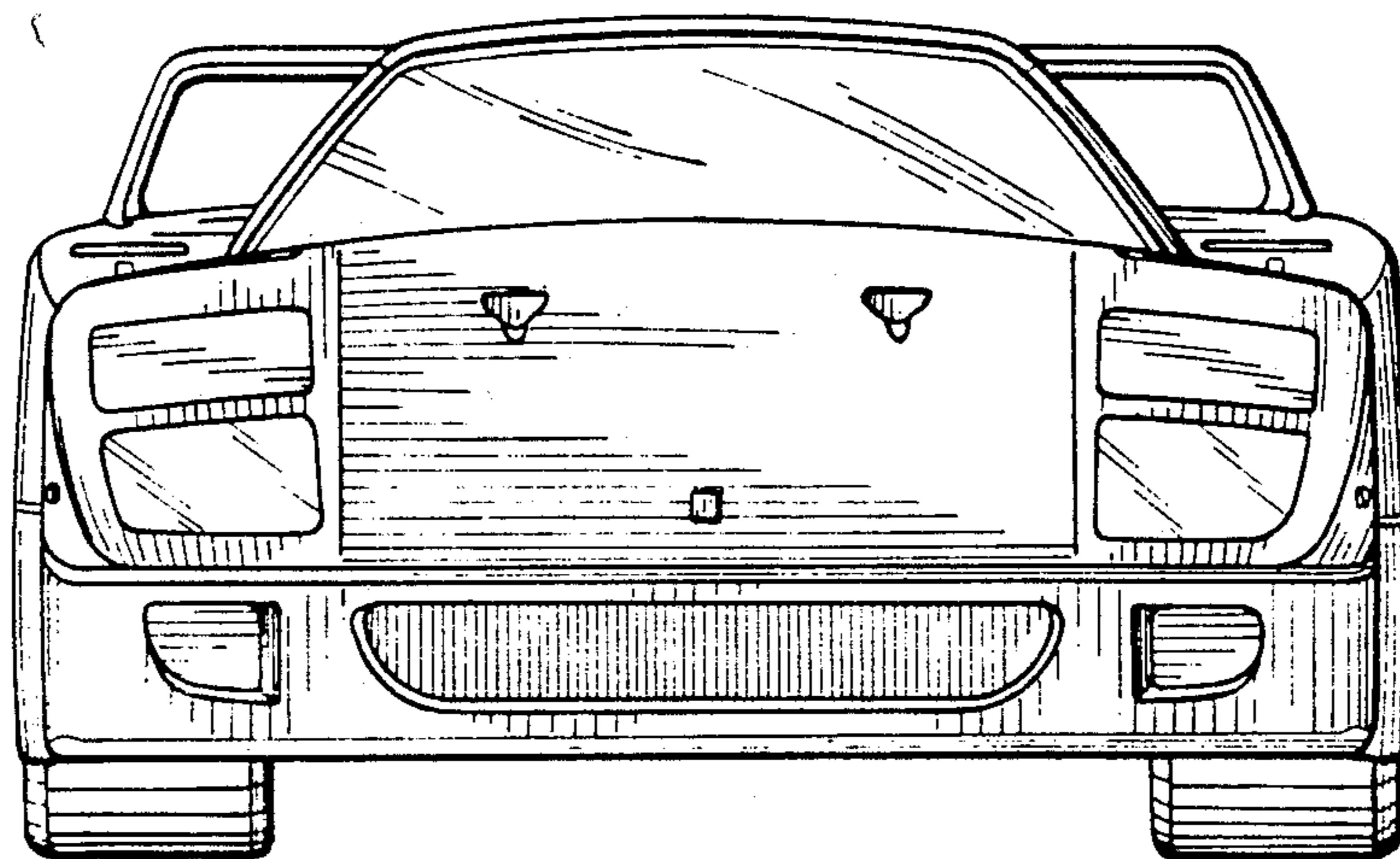

FIG. 3

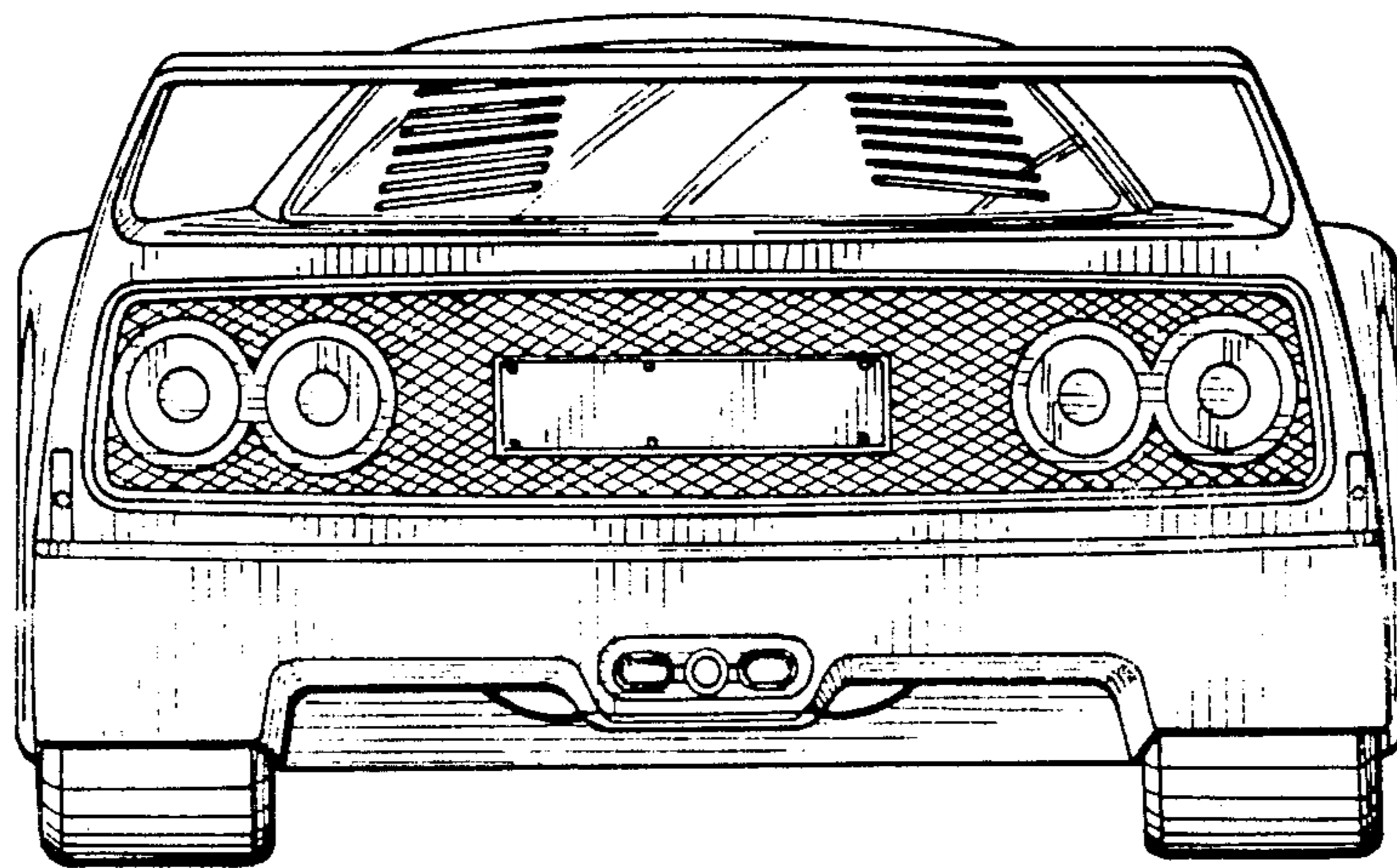

FIG. 4

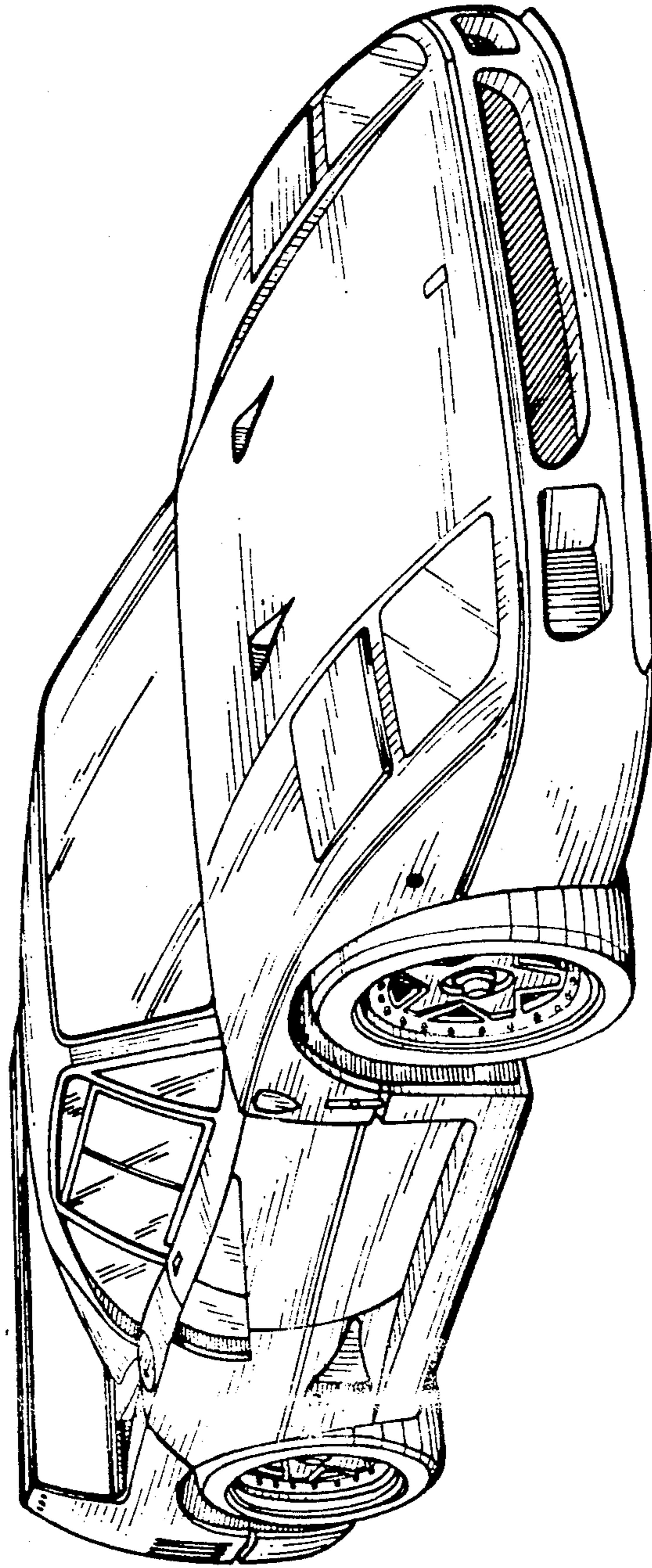

FIG. 5

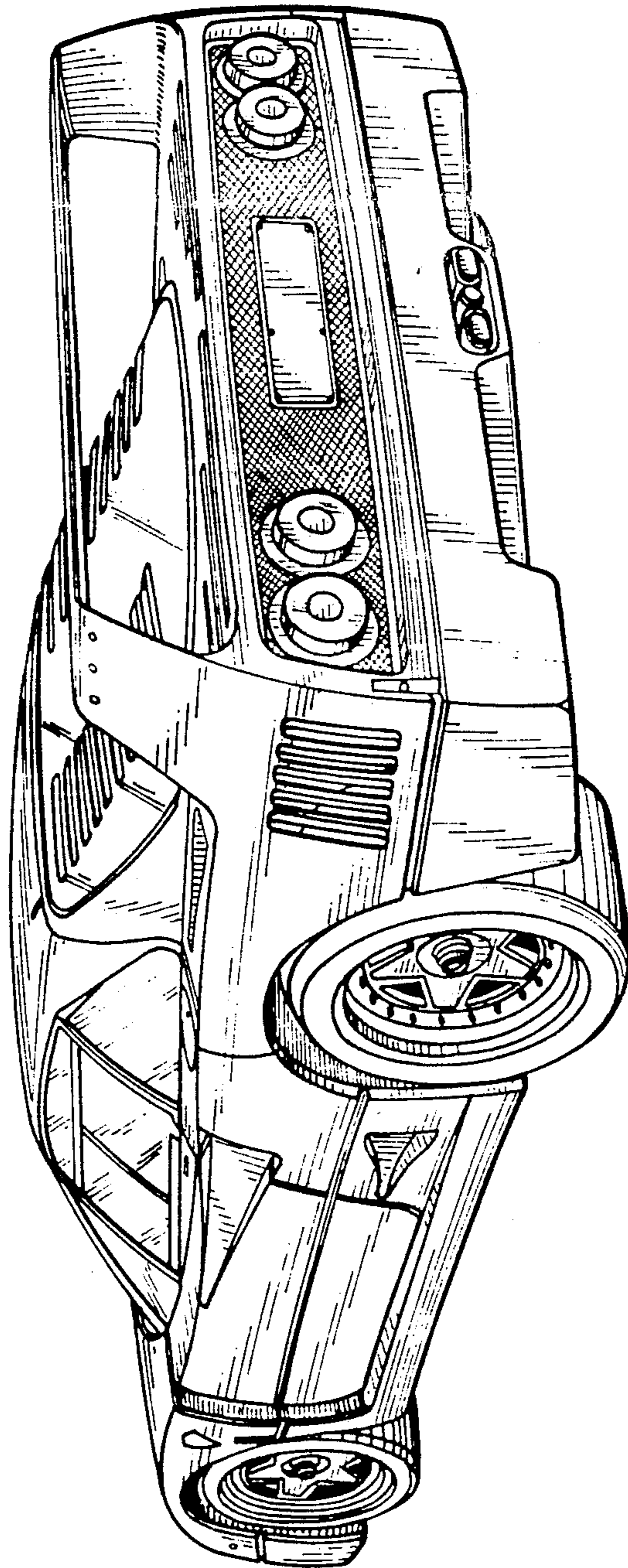

FIG. 6

