

[54] VEHICLE DECK RACK WITH POP-UP TIE DOWNS

[76] Inventor: John A. Bott, 931 Lakeshore Dr., Grosse Pointe Shores, Mich. 48236

[**] Term: 14 Years

[21] Appl. No.: 33,061

[22] Filed: Apr. 1, 1987

[52] U.S. Cl. D12/157

[58] Field of Search D12/157; 224/321, 324, 224/325, 326, 309, 316

[56] References Cited

U.S. PATENT DOCUMENTS

D. 280,983	10/1985	Schinella	D12/157
4,099,658	7/1978	Bott	224/42.1 F
4,182,471	6/1979	Bott	224/326
4,239,139	12/1980	Bott	224/324
4,293,159	10/1981	Bott	296/91
4,295,587	10/1981	Bott	224/321
4,364,500	12/1982	Bott	224/325
4,427,141	1/1984	Bott	224/325
4,431,123	2/1984	Bott	224/321
4,432,478	2/1984	Bott	224/321
4,440,333	4/1984	Bott	224/324
4,460,116	7/1984	Bott	224/321
4,838,467	6/1989	Bott	224/326

Primary Examiner—James M. Gandy
Attorney, Agent, or Firm—Harness, Dickey & Pierce

[57] CLAIM

The ornamental design for a vehicle deck rack with pop-up tie downs, as shown and described.

DESCRIPTION

FIG. 1 is a perspective view of a vehicle deck rack with pop-up tie downs showing my new design it being understood that the fragmentary broken line showing of an automotive vehicle is for illustrative purposes only and forms no part of the claimed design;

FIG. 2 is an enlarged top plan view thereof;

FIG. 3 is an enlarged right end elevation view thereof looking in the direction of arrow III in FIG. 1;

FIG. 4 is an enlarged front elevation view thereof looking in the direction of arrow IV in FIG. 1;

FIG. 5 is an enlarged rear elevation view thereof looking in the direction of arrow V in FIG. 1;

FIG. 6 is a greatly enlarged cross-sectional view thereof taken along line VI—VI in FIG. 2;

FIG. 7 is a greatly enlarged cross-sectional view thereof taken along line VII—VII in FIG. 2;

FIG. 8 is a greatly enlarged fragmentary perspective view of the pop-up tie down portion thereof within the circle VIII of FIG. 1;

FIG. 9 is a greatly enlarged fragmentary perspective view similar to FIG. 8 with the pop-up tie down element in raised condition; and

FIG. 10 is a greatly enlarged fragmentary side elevational view of the end of one of the slats thereof within the circle X of FIG. 1.

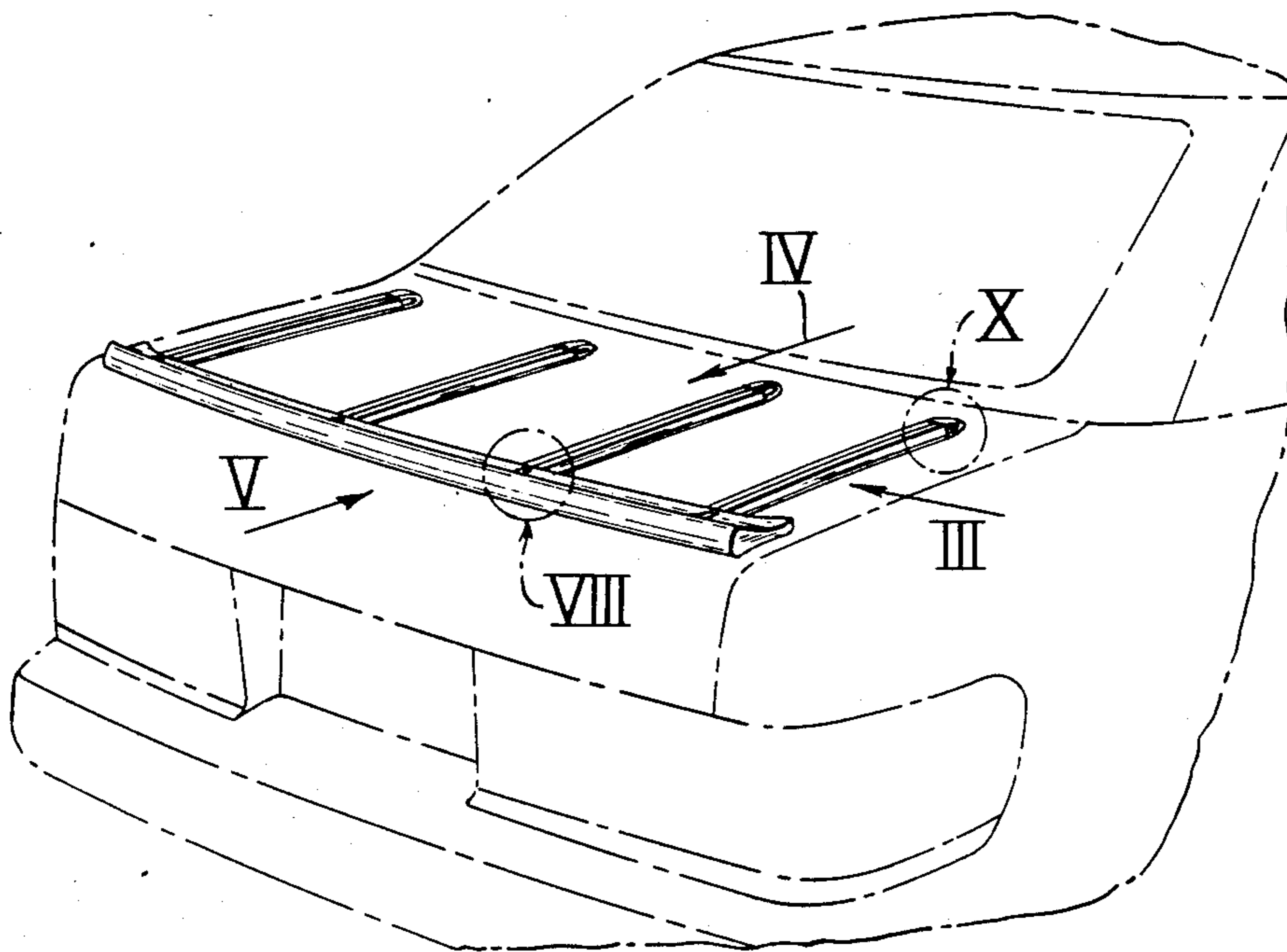

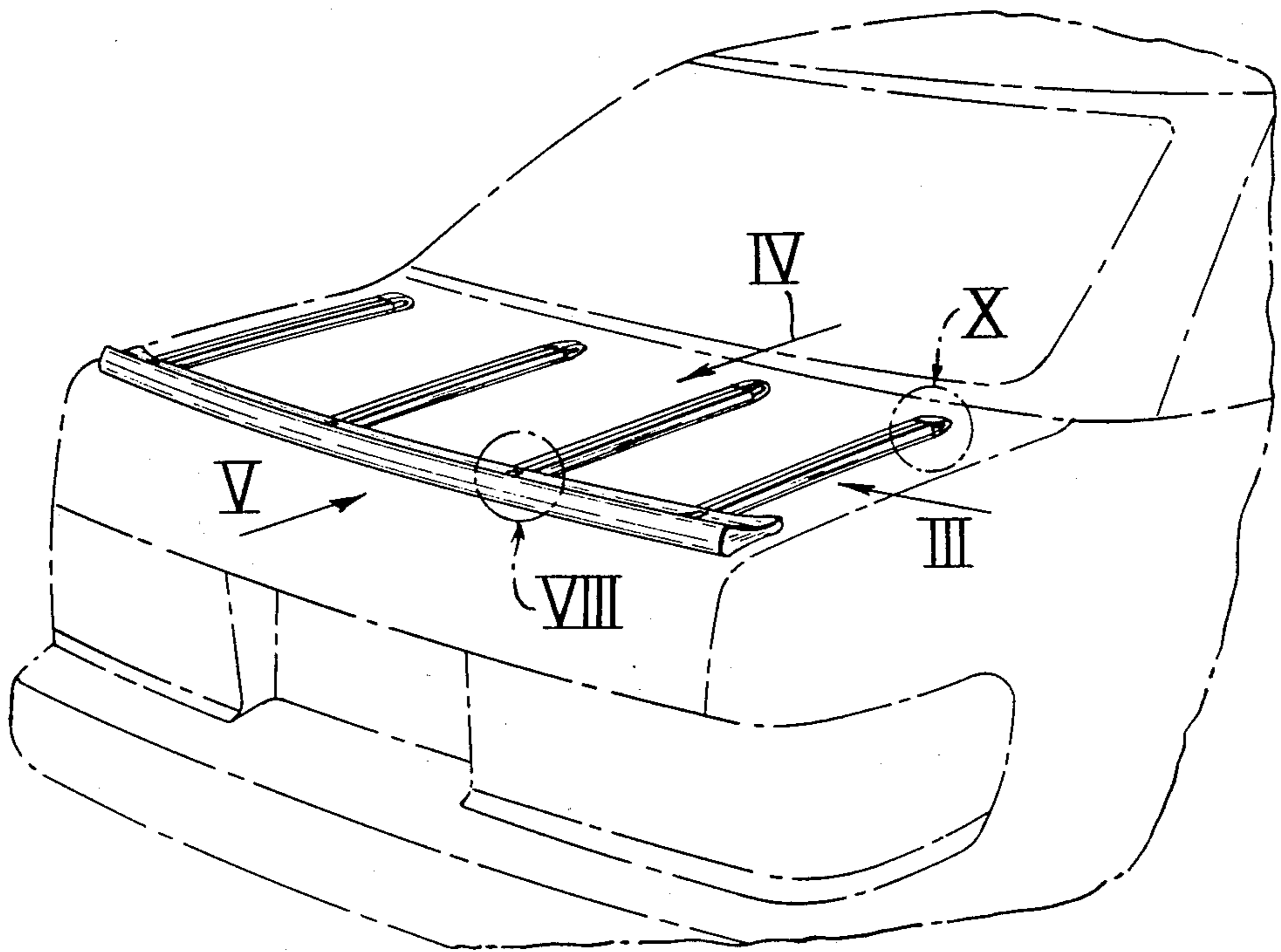

Fig. 1.

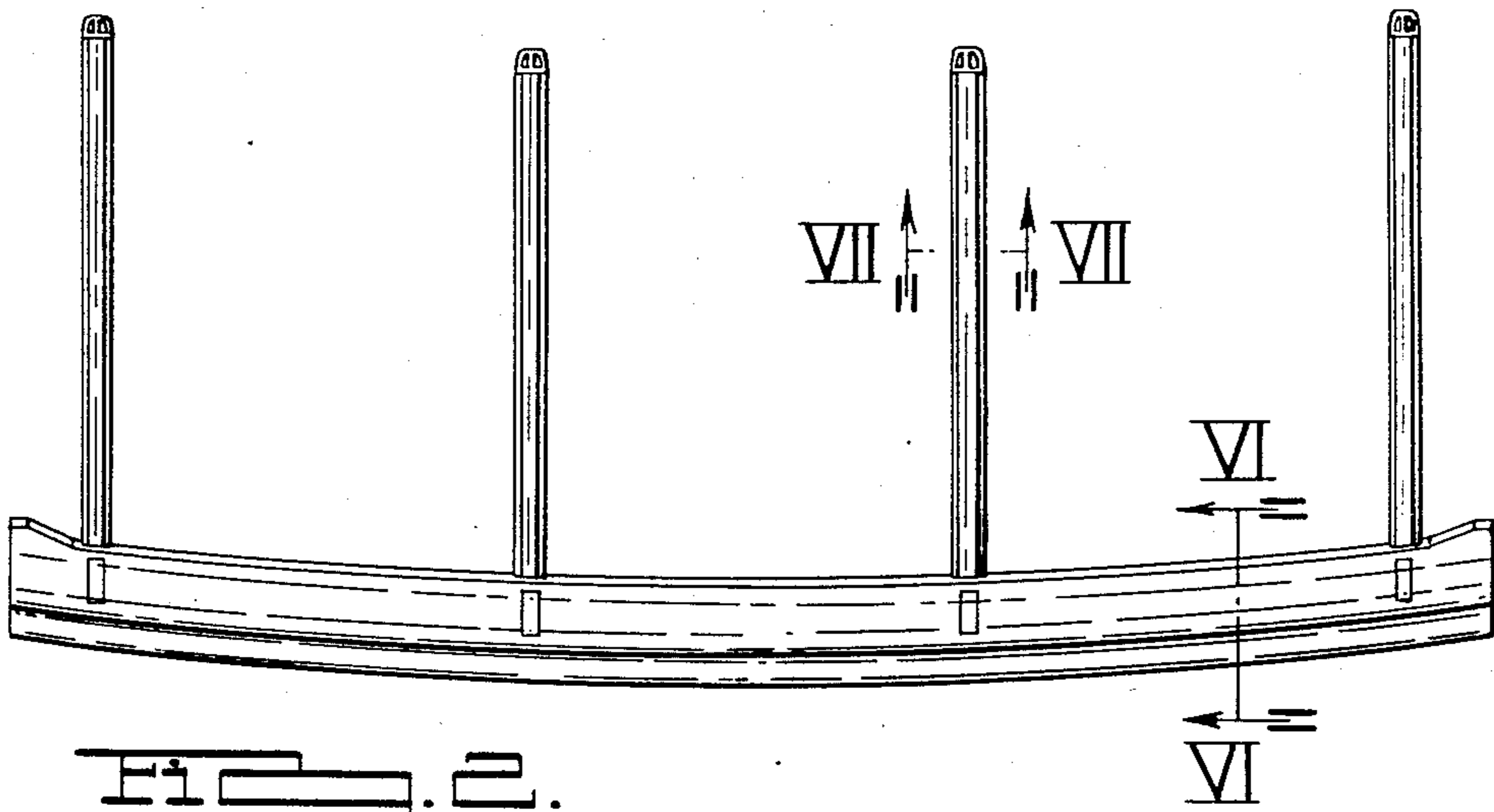

Fig. 2.



FIG. 3.



FIG. 4.



FIG. 5.

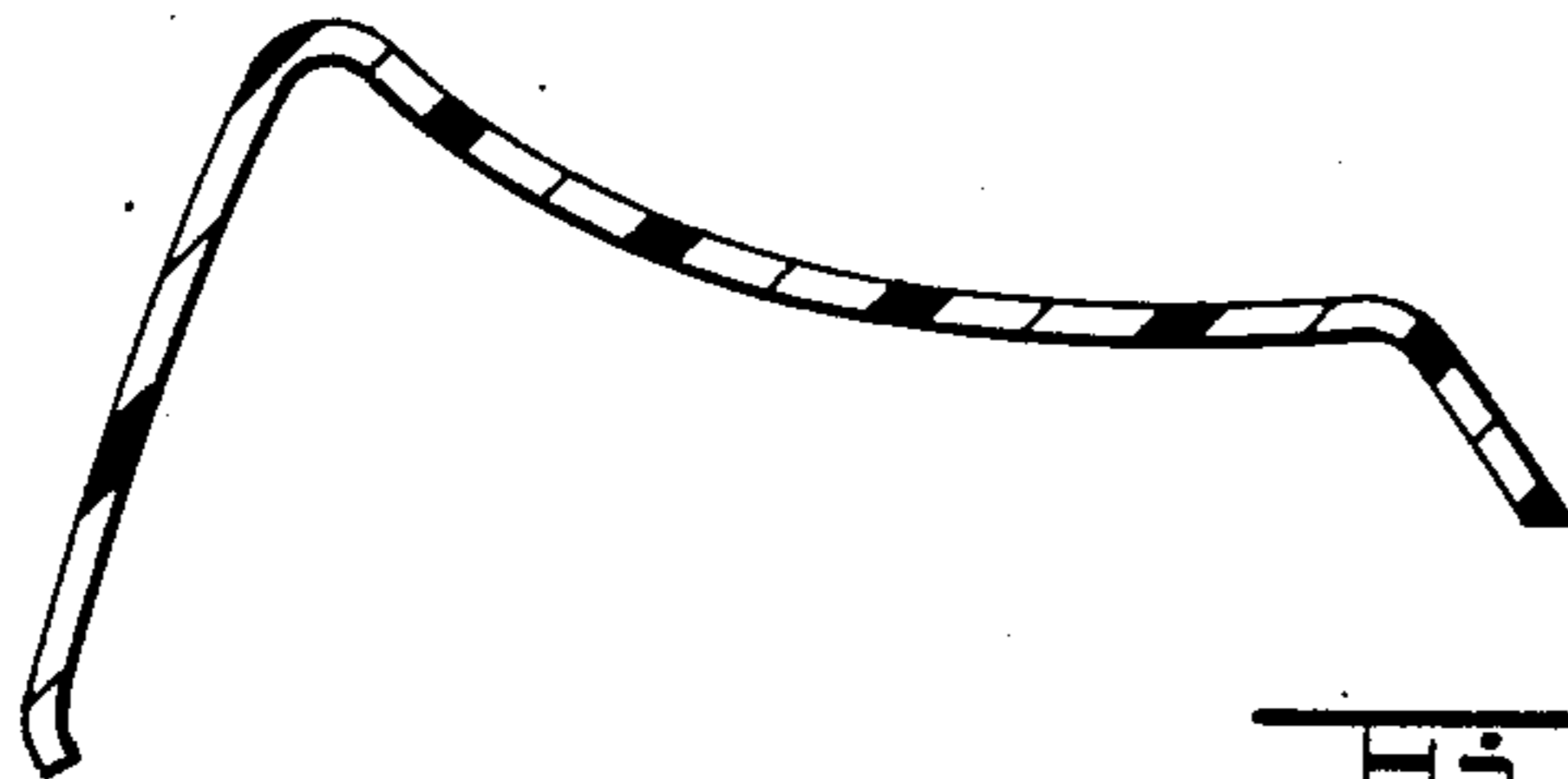

FIG. 6.

