

[54] PAIR OF WINDOWS FOR THE ROOF OF A VAN OR SIMILAR VEHICLE

[75] Inventor: Oyvind Haugestad, 67746 Klinger Lake Rd., Sturgis, Mich. 49091

[73] Assignee: Oyvind Haugestad, Sturgis, Mich.

[\*\*] Term: 14 Years

[21] Appl. No.: 24,222

[22] Filed: Mar. 10, 1987

[52] U.S. Cl. .... D12/183

[58] Field of Search ..... D12/183, 156, 99, 100, D12/103; D25/52; 296/215, 145; 52/200

[56] References Cited

U.S. PATENT DOCUMENTS

D. 147,738	10/1947	Wakefield	.....	D25/52
D. 203,038	11/1965	Wozena	.....	D12/156
D. 203,670	2/1966	Simos	.....	D12/156
D. 212,468	10/1968	Kronefeld et al.	.....	D12/156
D. 213,189	1/1969	Ritter et al.	.....	D12/156
D. 231,344	4/1974	Miller et al.	.....	D12/103
D. 244,182	5/1977	Skidmore et al.	.....	D12/156
D. 249,034	8/1978	Snyder	.....	D12/156
D. 249,495	9/1978	Wallace et al.	.....	D12/99
D. 250,331	11/1978	Snyder	.....	D12/156
D. 250,525	12/1978	Snyder	.....	D12/156
D. 251,292	3/1979	Johnson et al.	.....	D12/156
3,764,179	10/1973	Burton	.....	296/215

OTHER PUBLICATIONS

Motor Trend, 8/85, p. 41, Real Side Window of Pontiac Trans Am K-Type Wagon.

Primary Examiner—James M. Gandy  
Attorney, Agent, or Firm—Flynn, Thiel, Boutell & Tanis

[57] CLAIM

The ornamental design for a pair of windows for the roof of a van or similar vehicle, as shown and described.

DESCRIPTION

FIG. 1 is a perspective view taken from the front, left side and top of a pair of windows for the roof of a van or similar vehicle embodying my new design;

FIG. 2 is an enlarged perspective view thereof taken more from the front and top than in FIG. 1;

FIG. 3 is a left side elevational view of the left window of the pair;

FIG. 4 is a top plan view of FIG. 2;

FIG. 5 is a bottom plan view of FIG. 2;

FIG. 6 is a right side elevational view of the inner side of the left window of the pair taken along line VI—VI in FIG. 4;

FIG. 7 is a front elevational view of FIG. 2; and

FIG. 8 is a rear elevational view of FIG. 2.

A supporting vehicle, here a van, is shown in broken lines in FIG. 1 and a fragment thereof is shown in FIG. 3, as typical environmental structure, and the structure shown in broken lines is not part of the design sought to be patented.

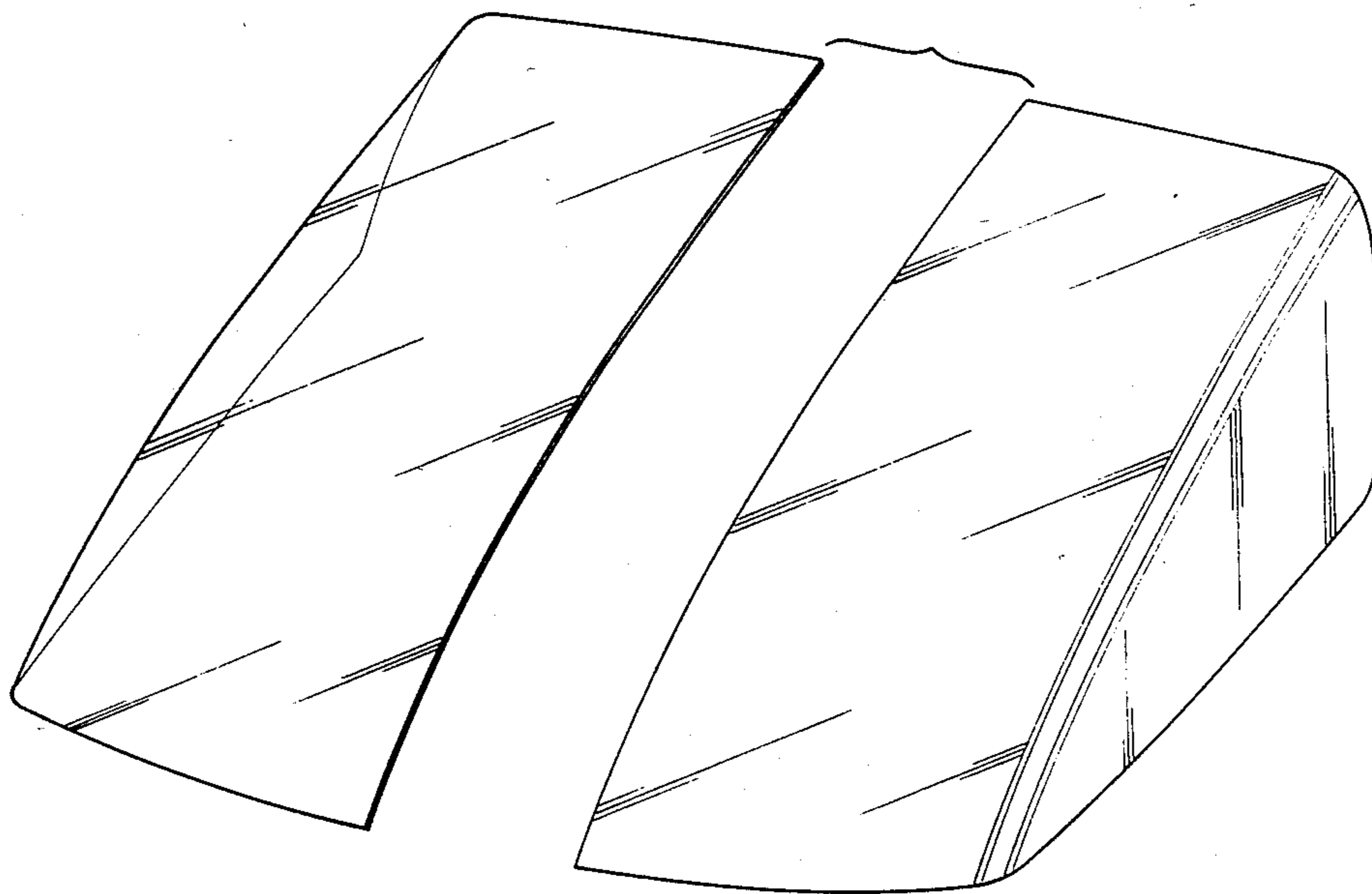

FIG. 1

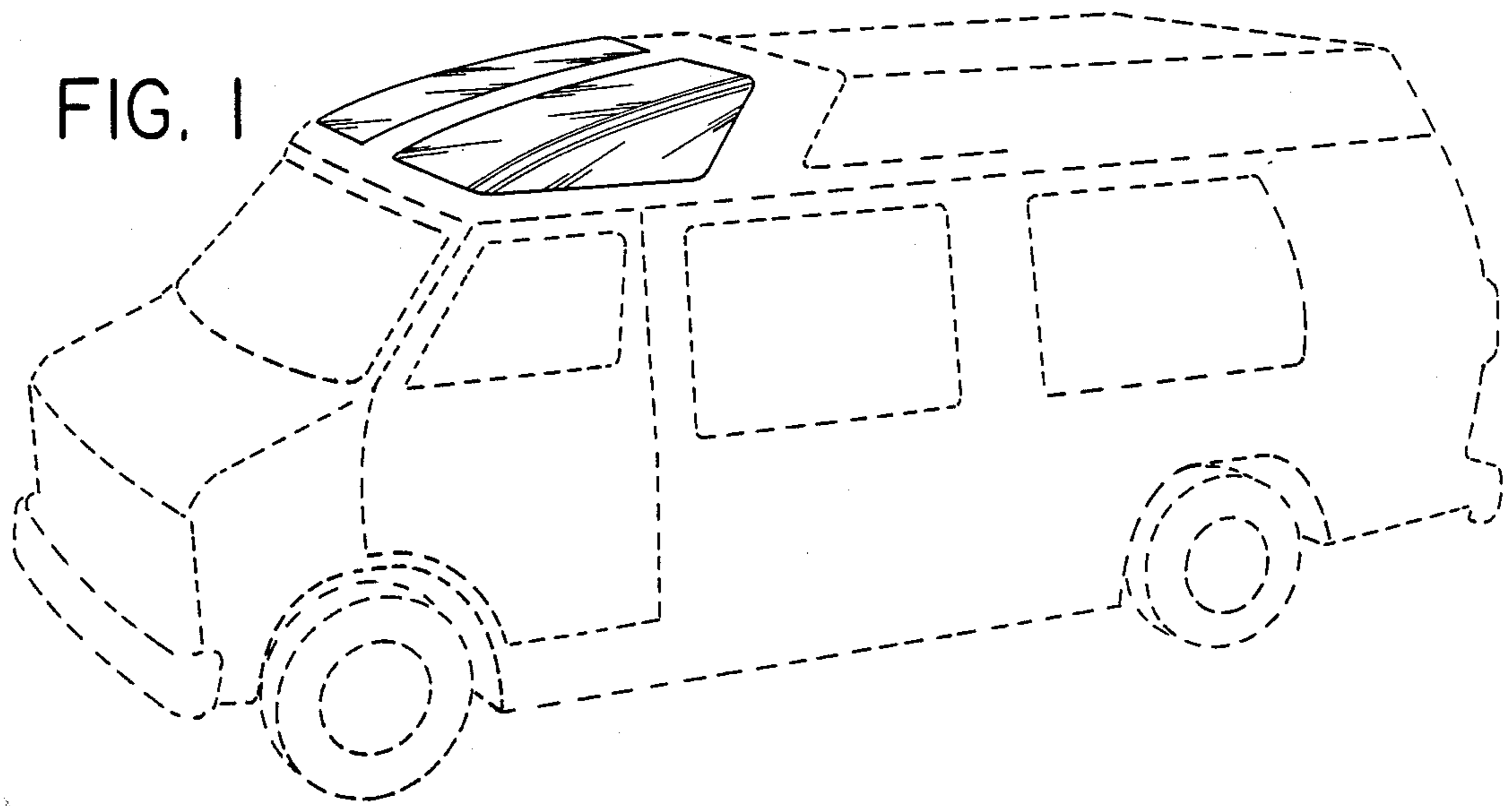

FIG. 2

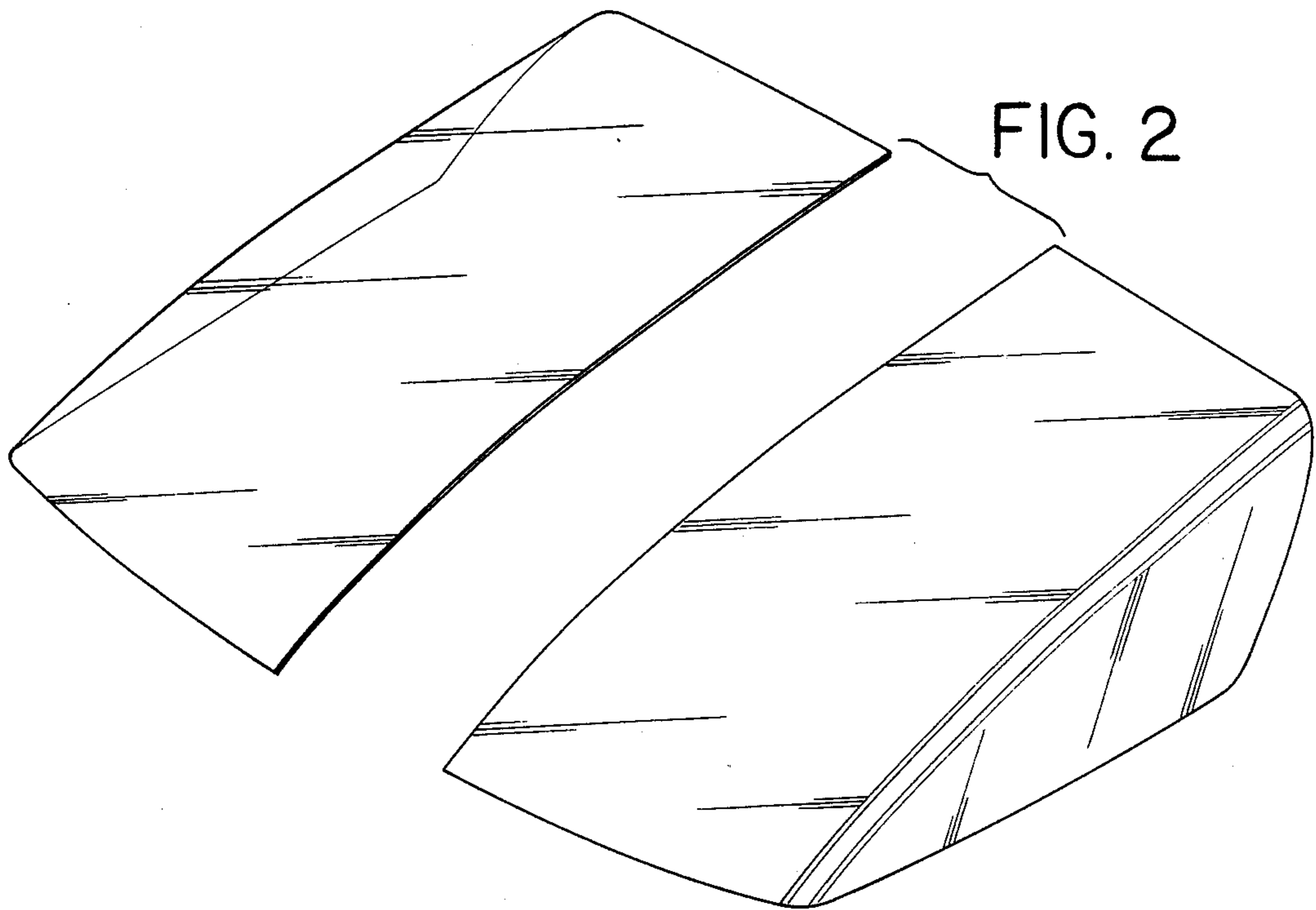
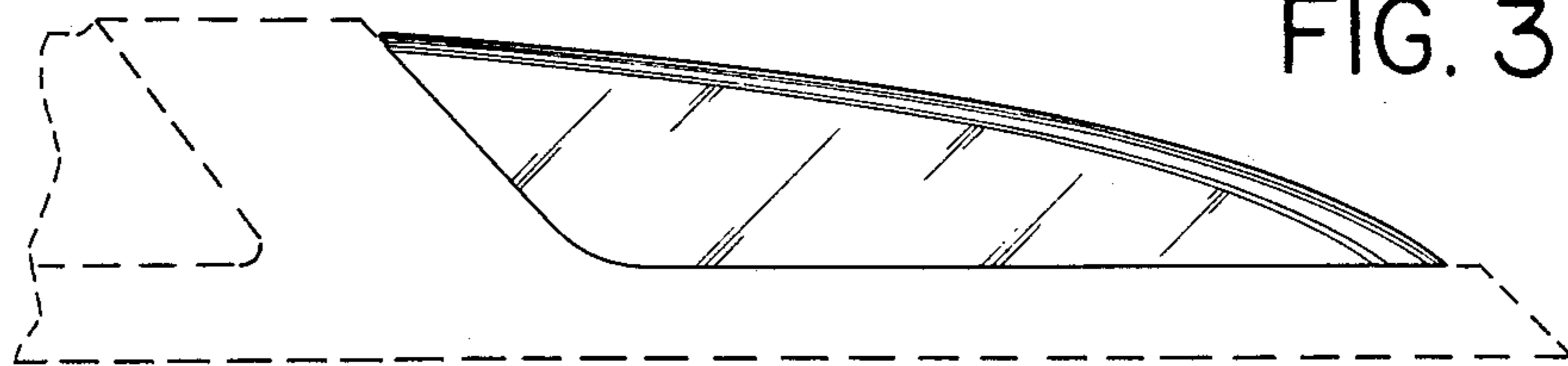

FIG. 3



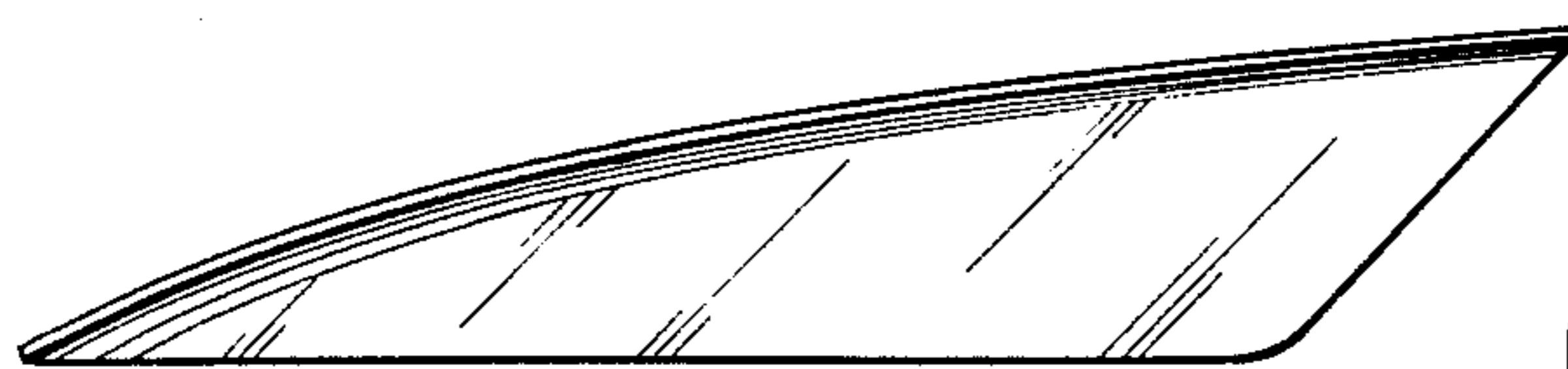
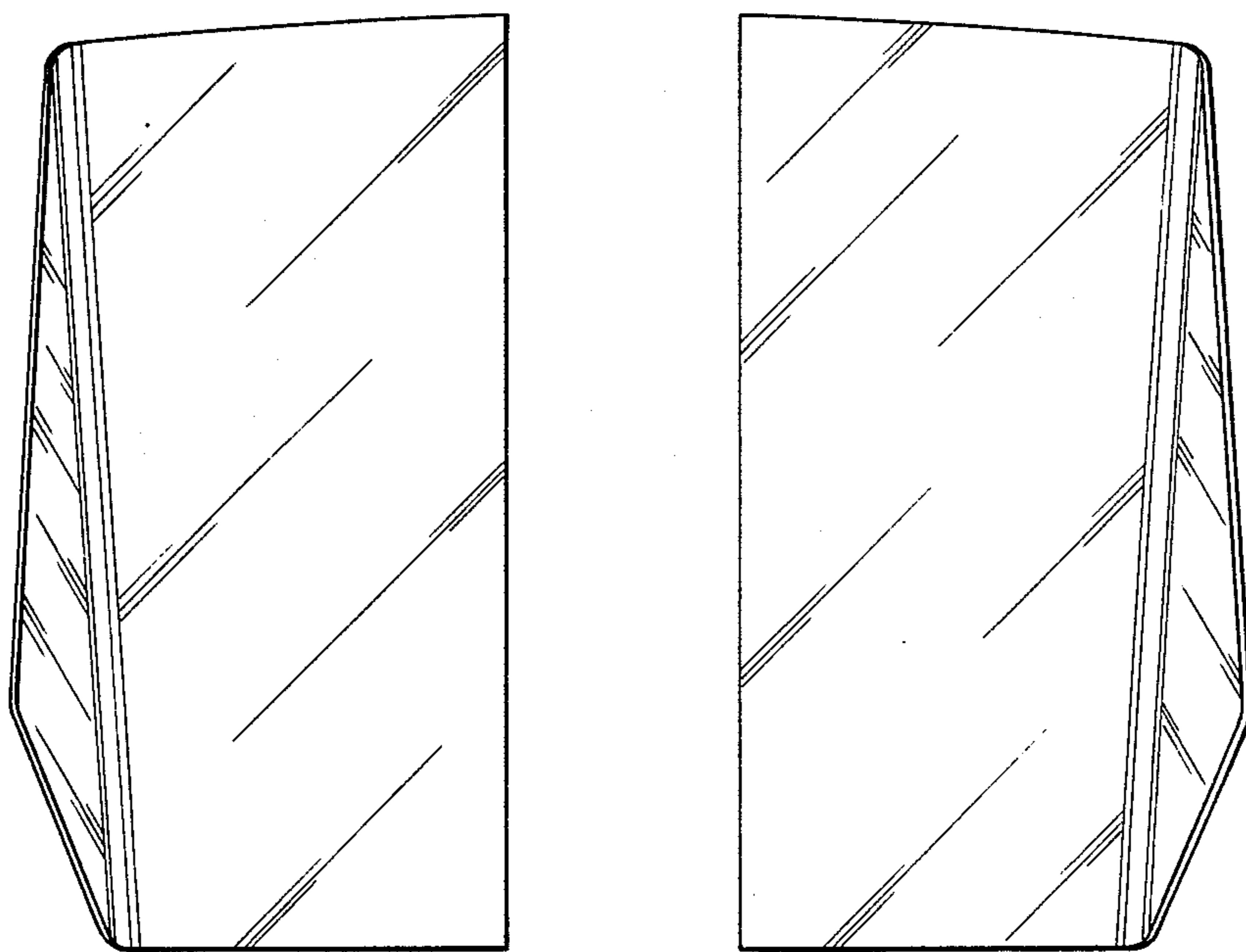
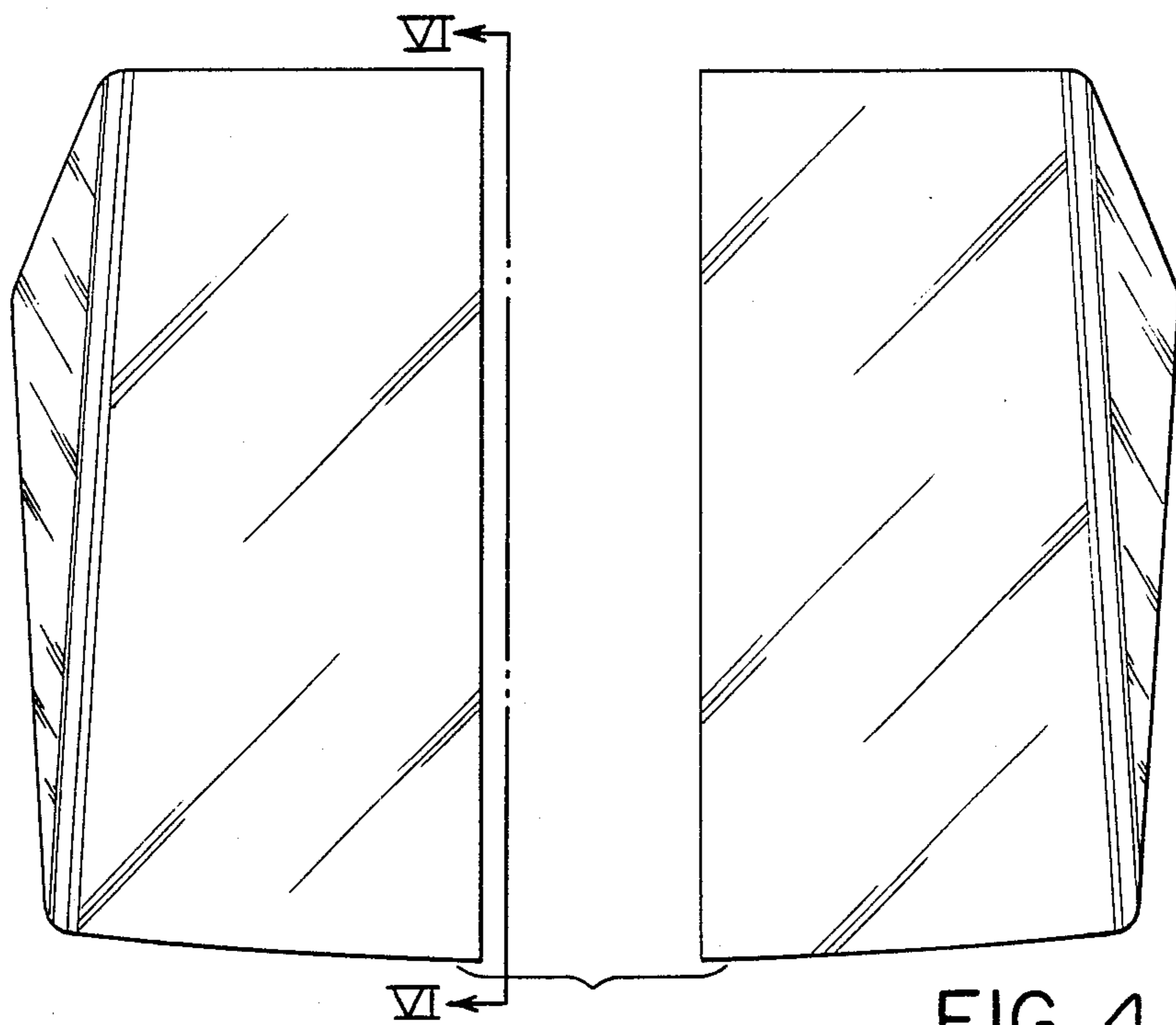



FIG. 7



FIG. 8