

[54] CARGO RESTRAINT FOR PICKUP TRUCK

[76] Inventor: William A. Berkan, Jr., P.O. Box 700, Dixon, Calif. 95620

[**] Term: 14 Years

[21] Appl. No.: 96,429

[22] Filed: Sep. 14, 1987

[52] U.S. Cl. D12/155

[58] Field of Search D12/155, 156; 410/106, 410/108, 110, 130, 129, 104, 139, 150

[56] References Cited

U.S. PATENT DOCUMENTS

D. 300,734	4/1989	Kruitbosch	D12/155
4,278,376	7/1981	Hunter	D12/155
4,770,579	9/1988	Aksamit	410/150
4,772,165	9/1988	Bartkus	410/150

OTHER PUBLICATIONS

J. C. Whitney Catalog No. 433B, ©1983, p. 42, Side Rails with Cab Hoop Load Bar, top left side of page.
J. C. Whitney Catalog No. 468K, ©1986, p. 50, Louvered Rail Rack & Side Rails for Pickups, top center of page.

Primary Examiner—James M. Gandy
Attorney, Agent, or Firm—Lothrop & West

[57] CLAIM

The ornamental design for a cargo restraint for pickup truck, as shown.

DESCRIPTION

FIG. 1 is a perspective view of a cargo restraint for pickup truck, showing our new design;
FIG. 2 is a front elevational view thereof;
FIG. 3 is a rear elevational view thereof;
FIG. 4 is an elevational view of one side thereof, the opposite side being a mirror image of the figure shown;
FIG. 5 is a top plan view thereof; and,
FIG. 6 is a bottom plan view thereof.

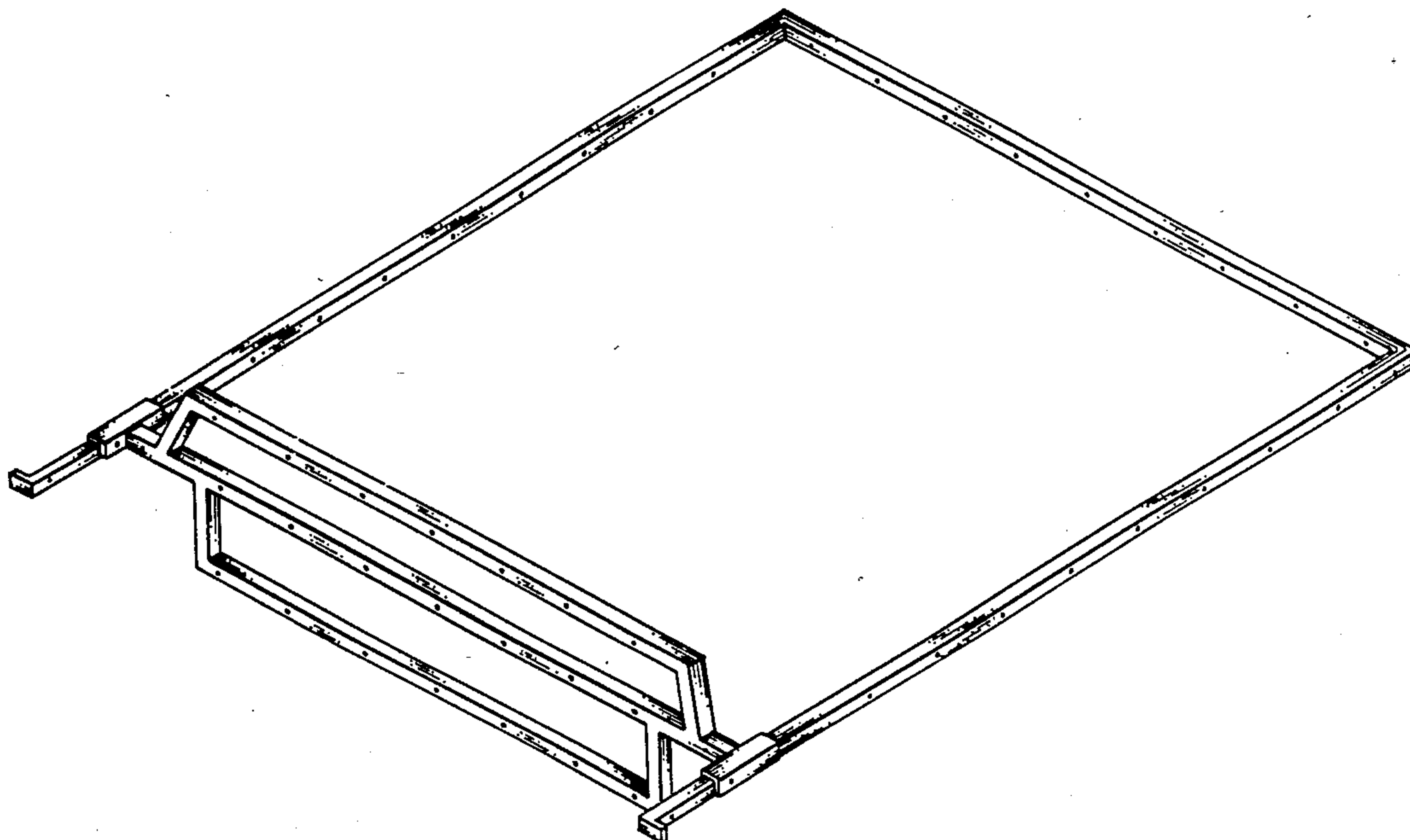

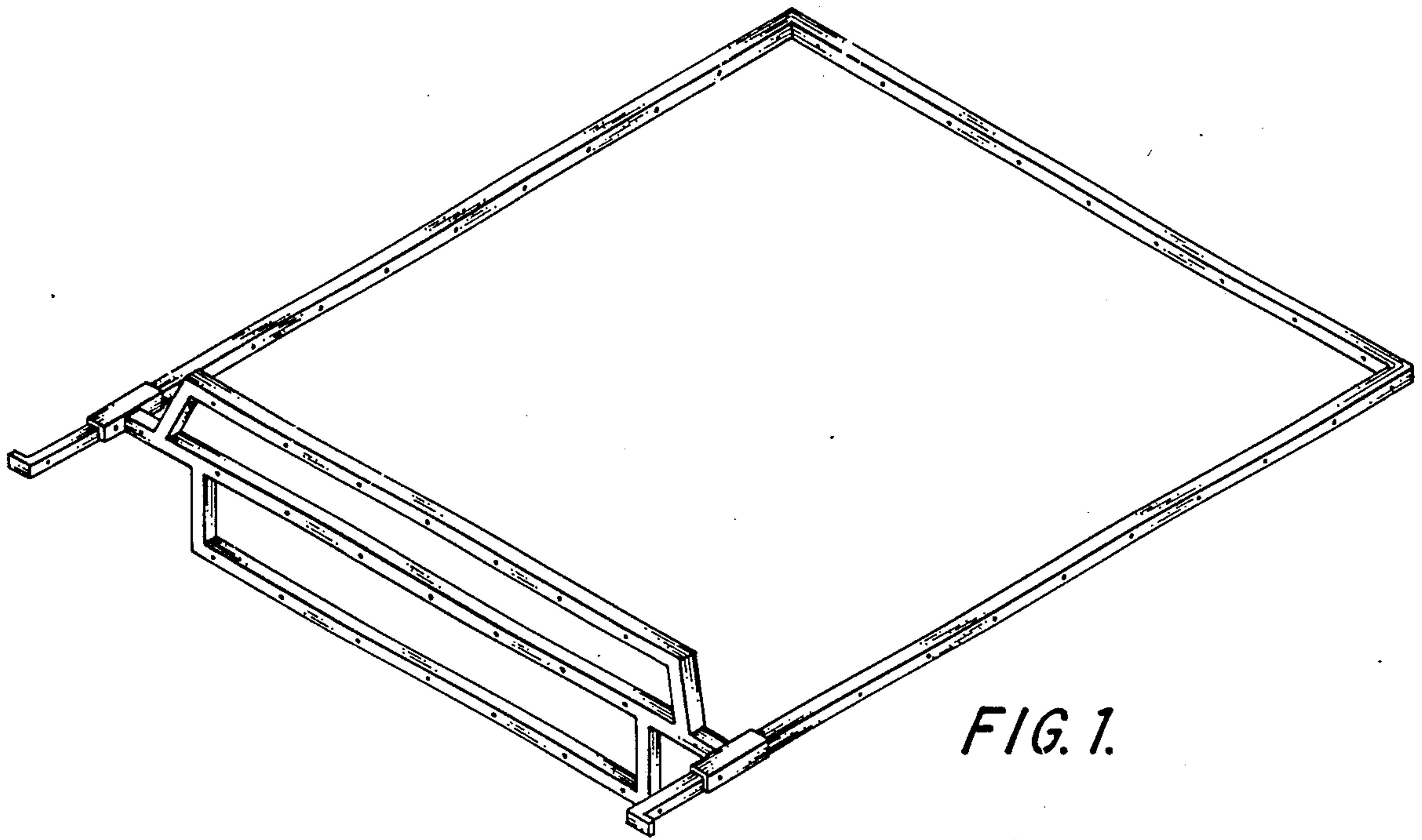

FIG. 1.

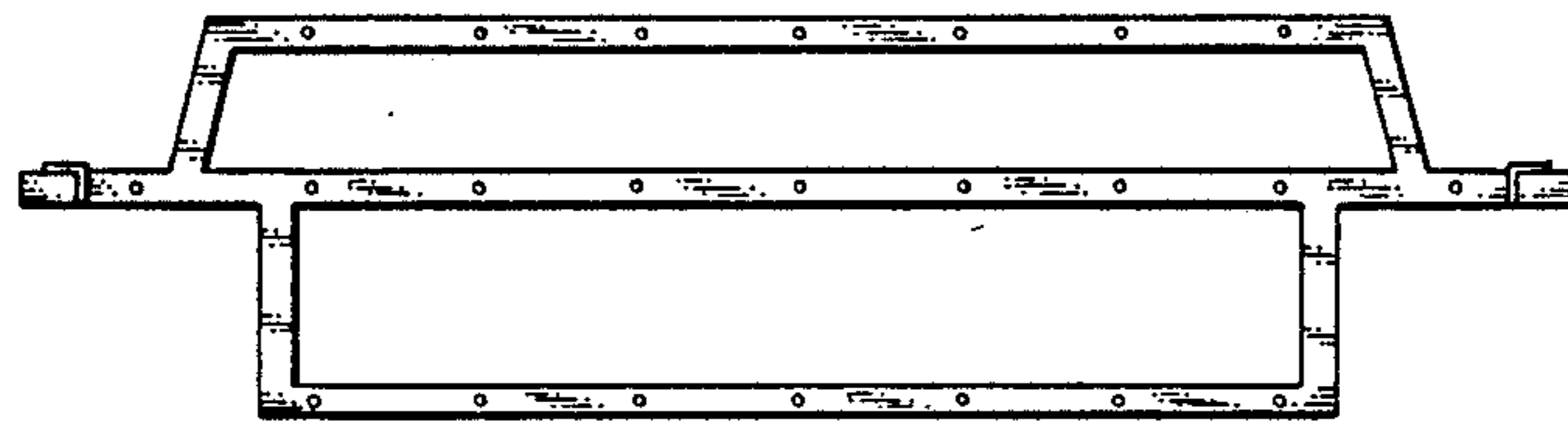

FIG. 2.

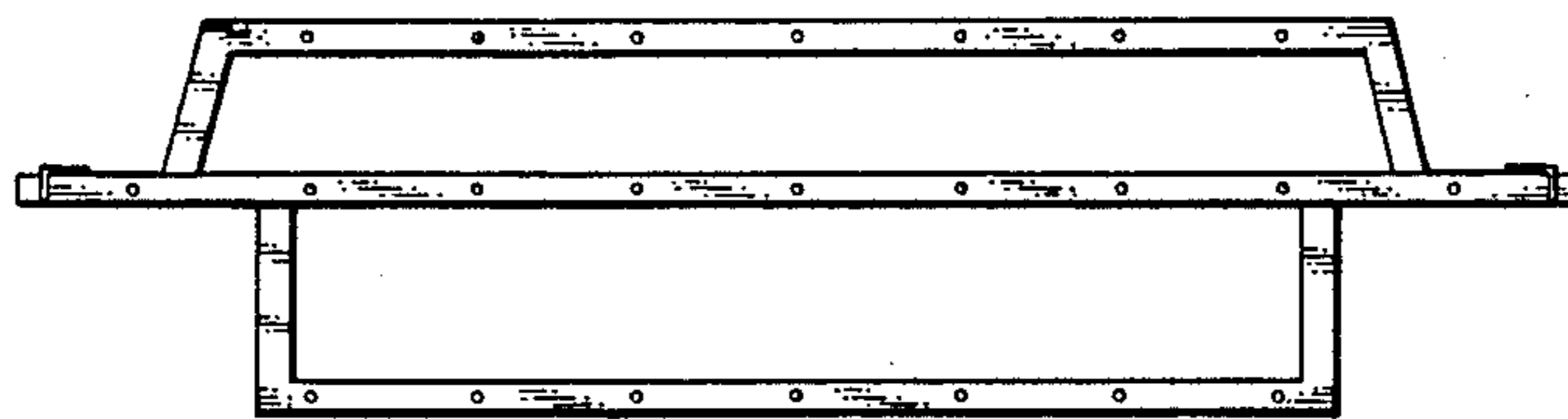

FIG. 3.

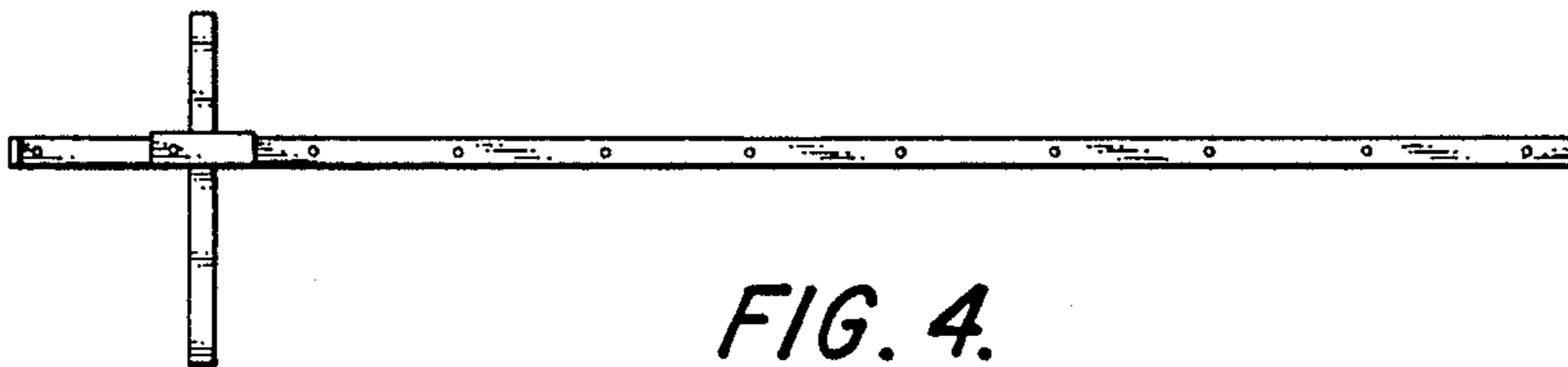

FIG. 4.

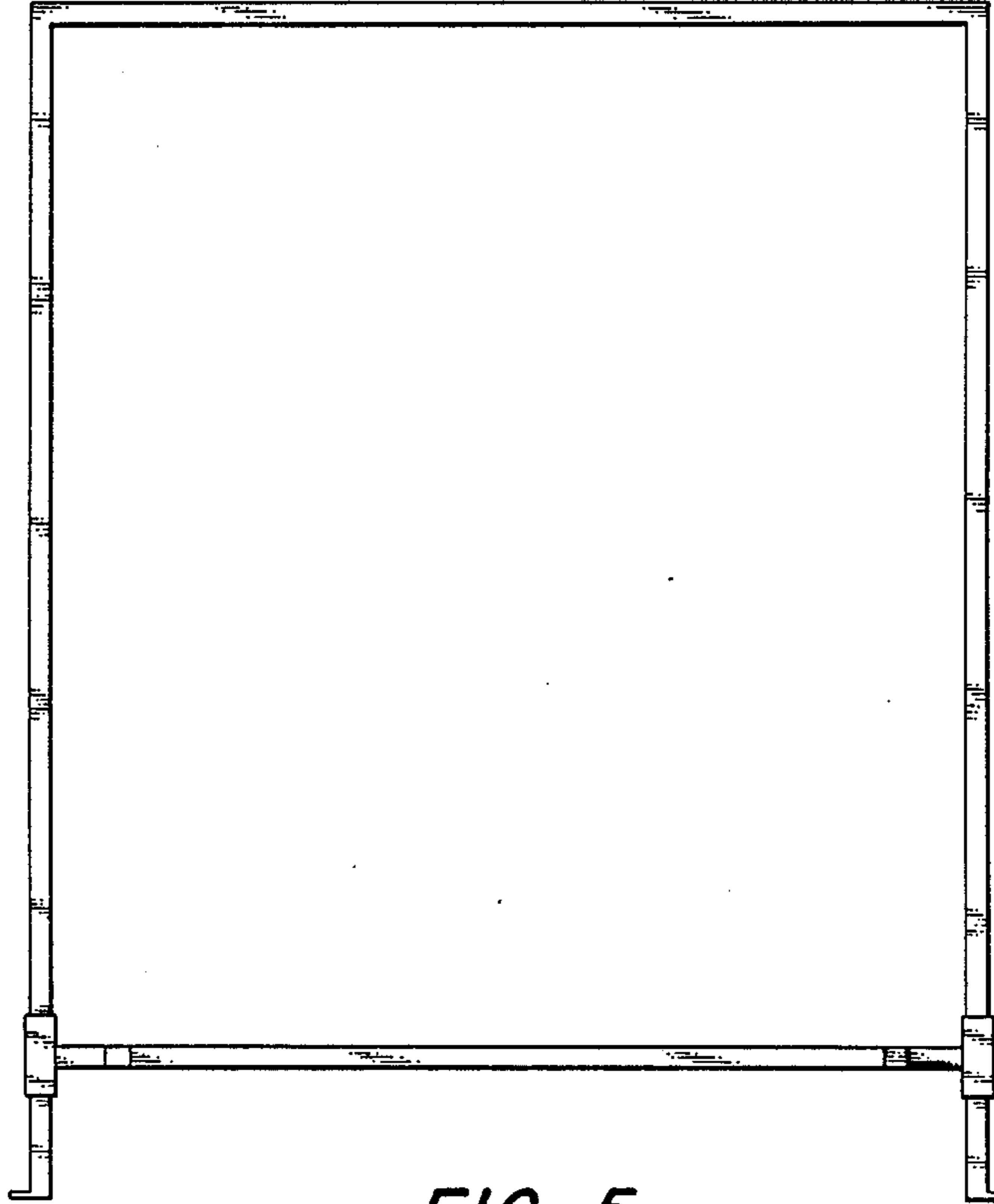

FIG. 5.

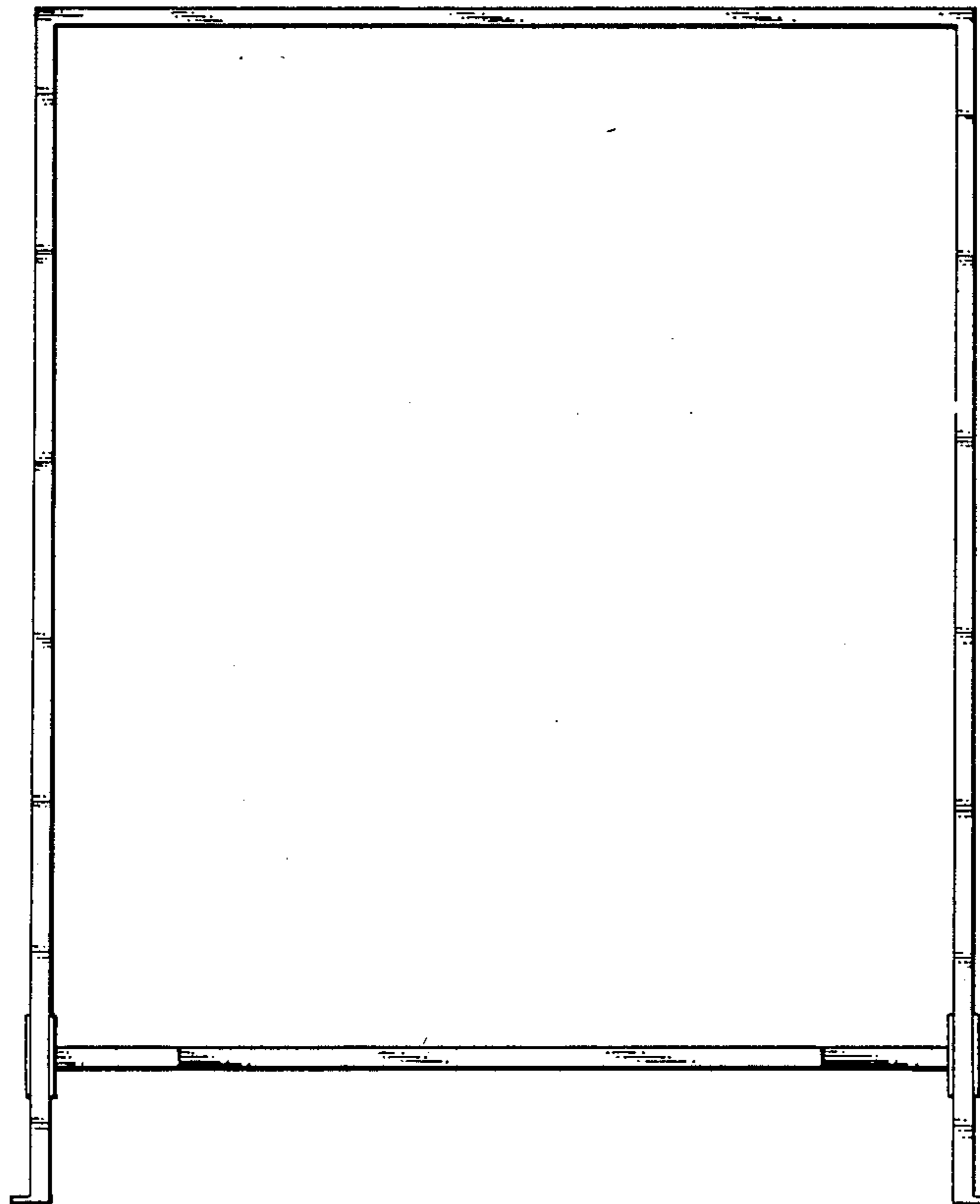

FIG. 6.