

United States Patent [19]

Iwagami

[11] Patent Number: **Des. 305,939**

[45] Date of Patent: **** Feb. 6, 1990**

[54] **CLEARANCE LAMP FOR AN AUTOMOBILE**

[75] Inventor: **Hiroshi Iwagami, Yokohama, Japan**

[73] Assignee: **Toyota Jidosha Kabushiki Kaisha, Toyota, Japan**

[**] Term: **14 Years**

[21] Appl. No.: **48,918**

[22] Filed: **May 13, 1987**

[30] **Foreign Application Priority Data**

Aug. 19, 1986 [JP] Japan 61-32176

[52] U.S. Cl. **D26/28**

[58] Field of Search D26/28, 29, 34, 35, D26/36, 120, 122; 362/61, 80-83.4, 267, 330, 336, 337, 339

[56] **References Cited**

U.S. PATENT DOCUMENTS

- D. 230,501 2/1974 Boano D26/120
- D. 285,258 8/1986 Hamasaki D26/28
- D. 287,289 12/1986 Kato D26/28

- D. 291,923 9/1987 Kawaguchi D26/28
- D. 296,937 7/1988 Inada D26/28

FOREIGN PATENT DOCUMENTS

- 622879 4/1984 Japan .
- 670660 1/1986 Japan .

Primary Examiner—Susan J. Lucas
Attorney, Agent, or Firm—Cushman, Darby & Cushman

[57] **CLAIM**

The ornamental design for a clearance lamp for an automobile, as shown and described.

DESCRIPTION

FIG. 1 is a front perspective view of a clearance lamp for an automobile showing my new design; FIG. 2 is a front elevational view thereof; FIG. 3 is a rear elevational view thereof; FIG. 4 is a top plan view thereof; FIG. 5 is a bottom plan view thereof; FIG. 6 is a left side elevational view thereof; FIG. 7 is a right side elevational view thereof; and FIG. 8 is a cross sectional view taken along line VIII-VIII of FIG. 4.

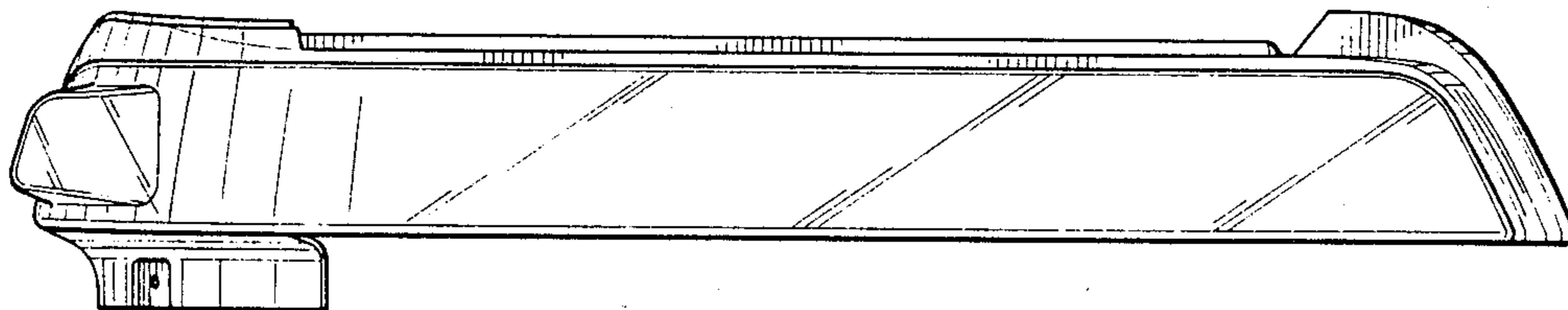

Fig. 1

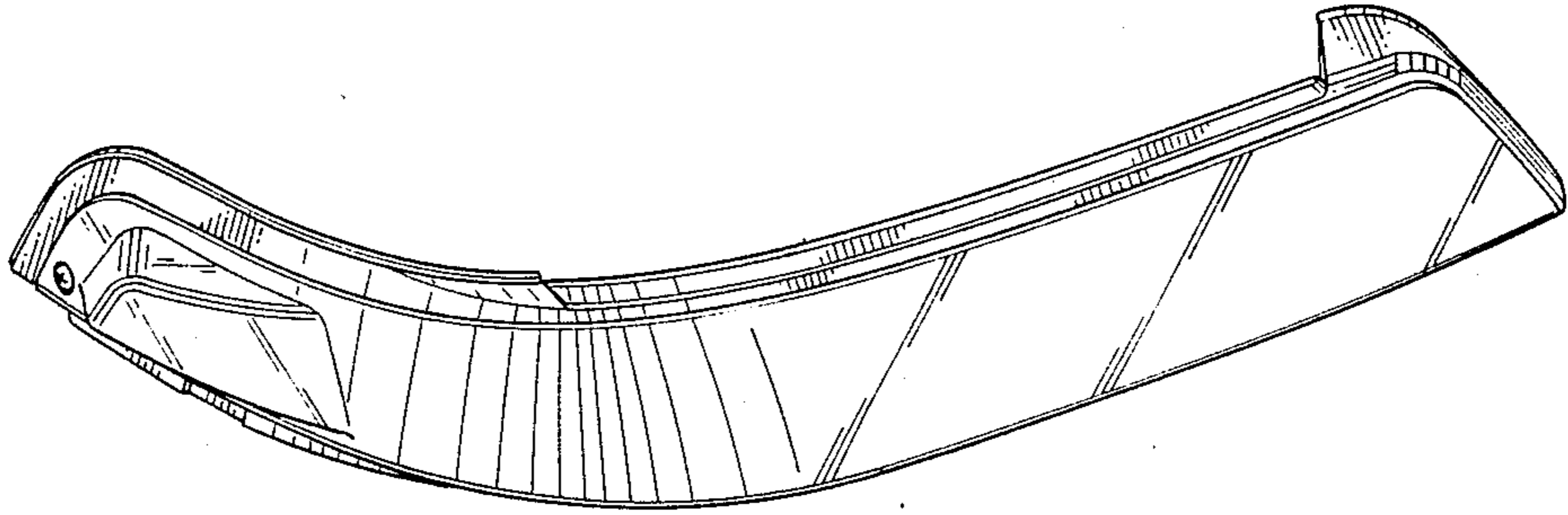

Fig. 2

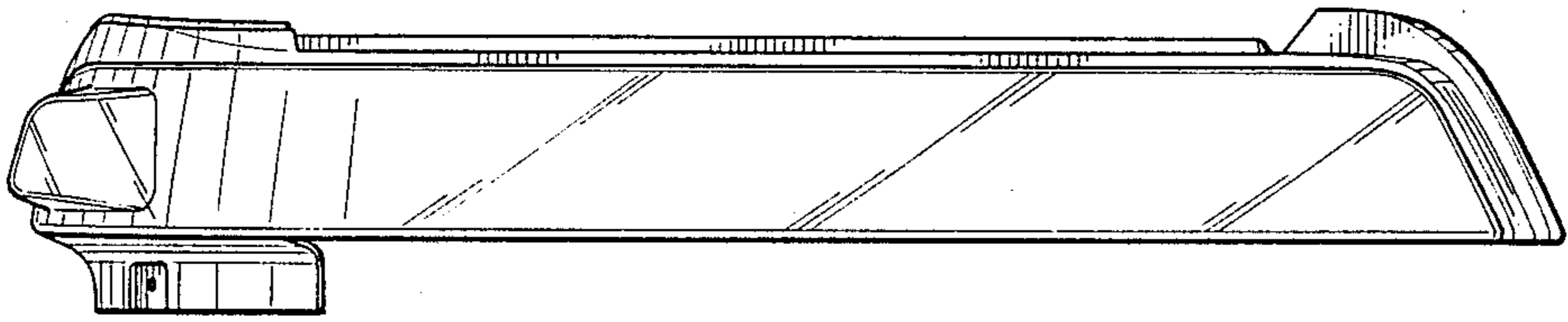

Fig. 3

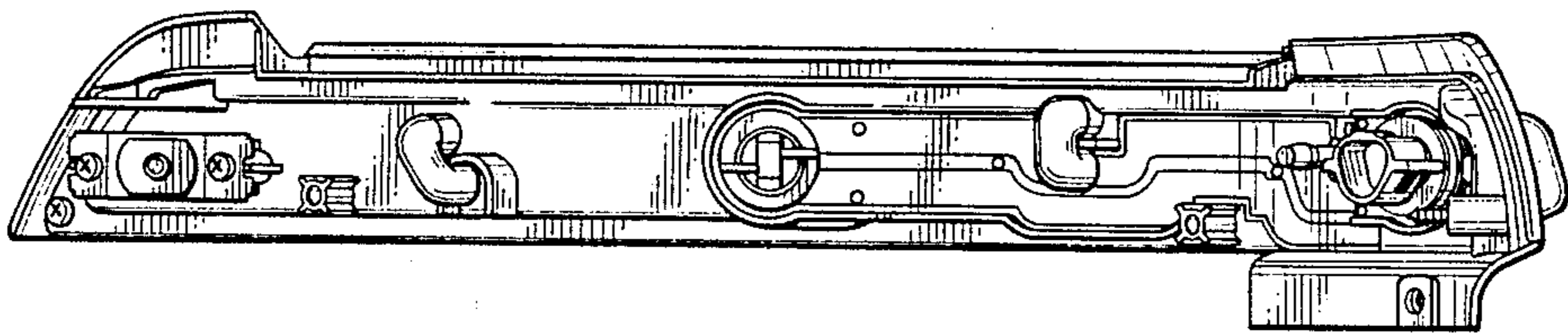

Fig. 4

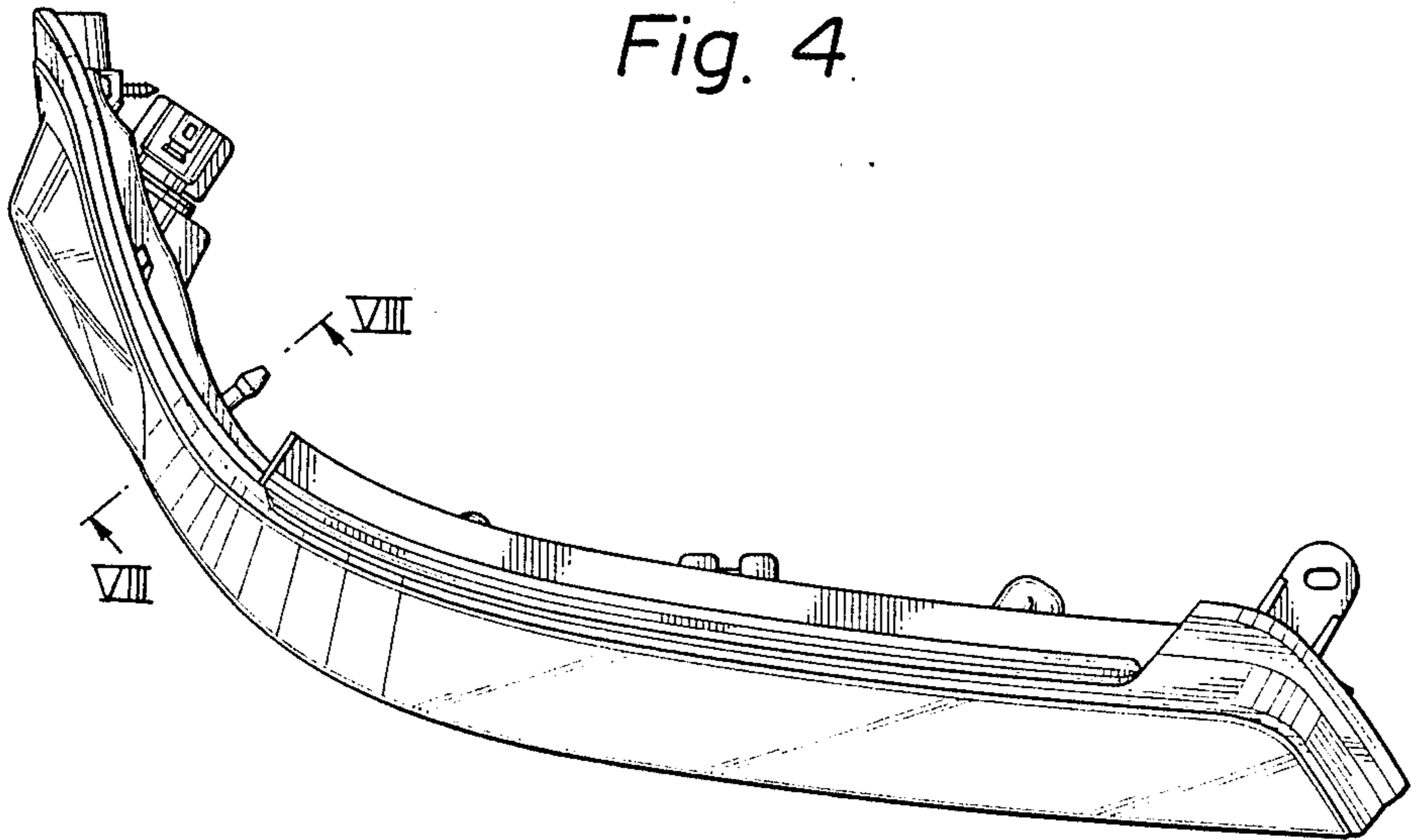

Fig. 5

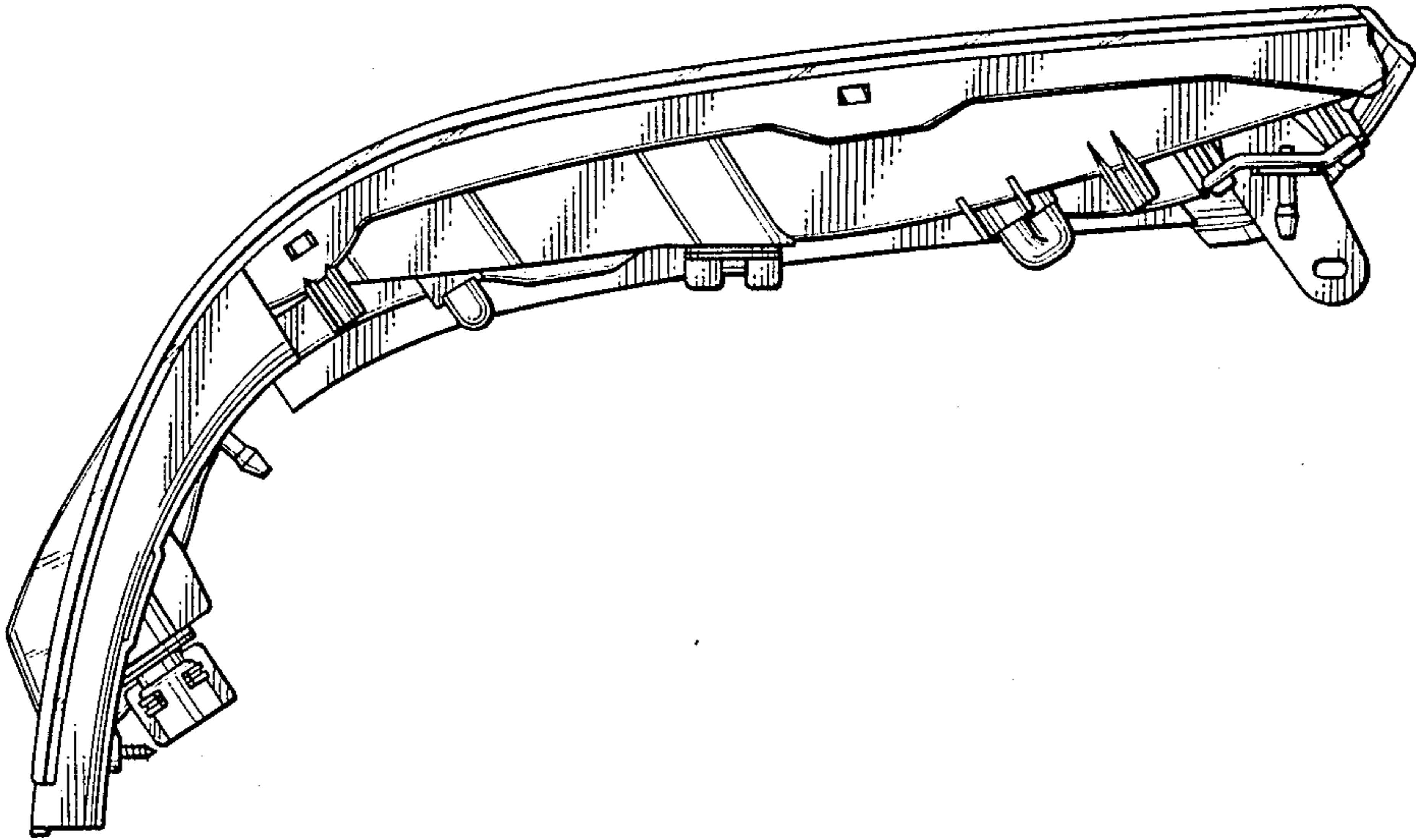

Fig. 6

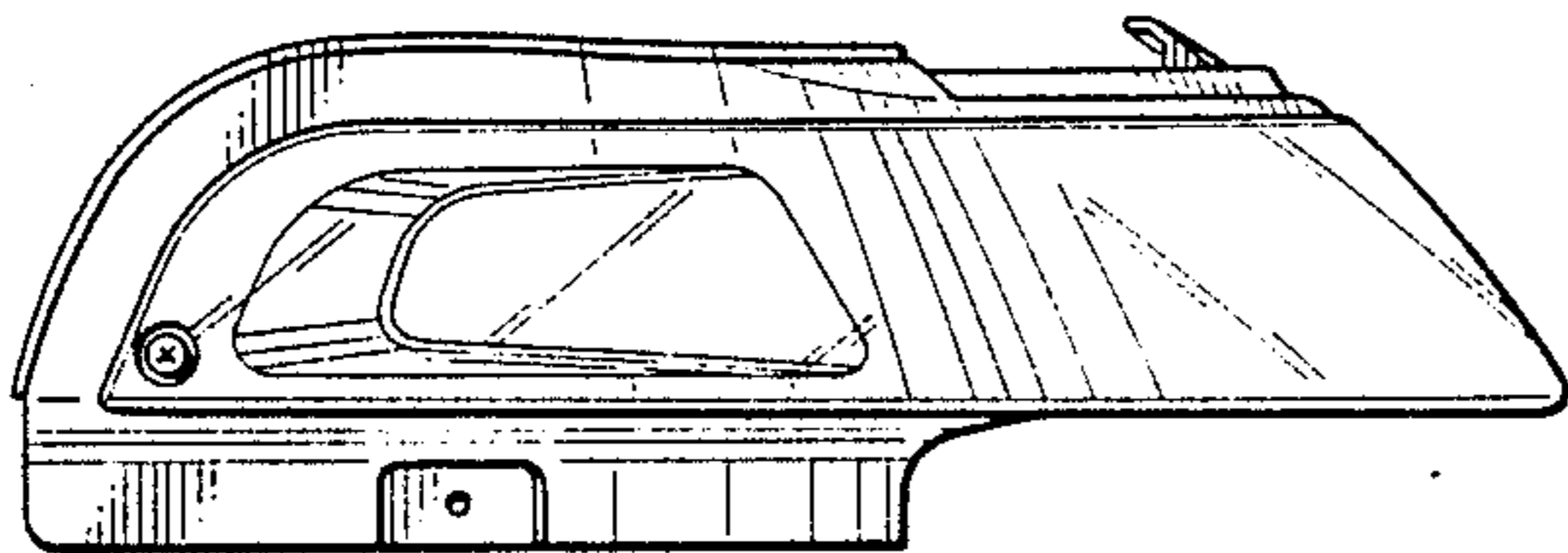

Fig. 7

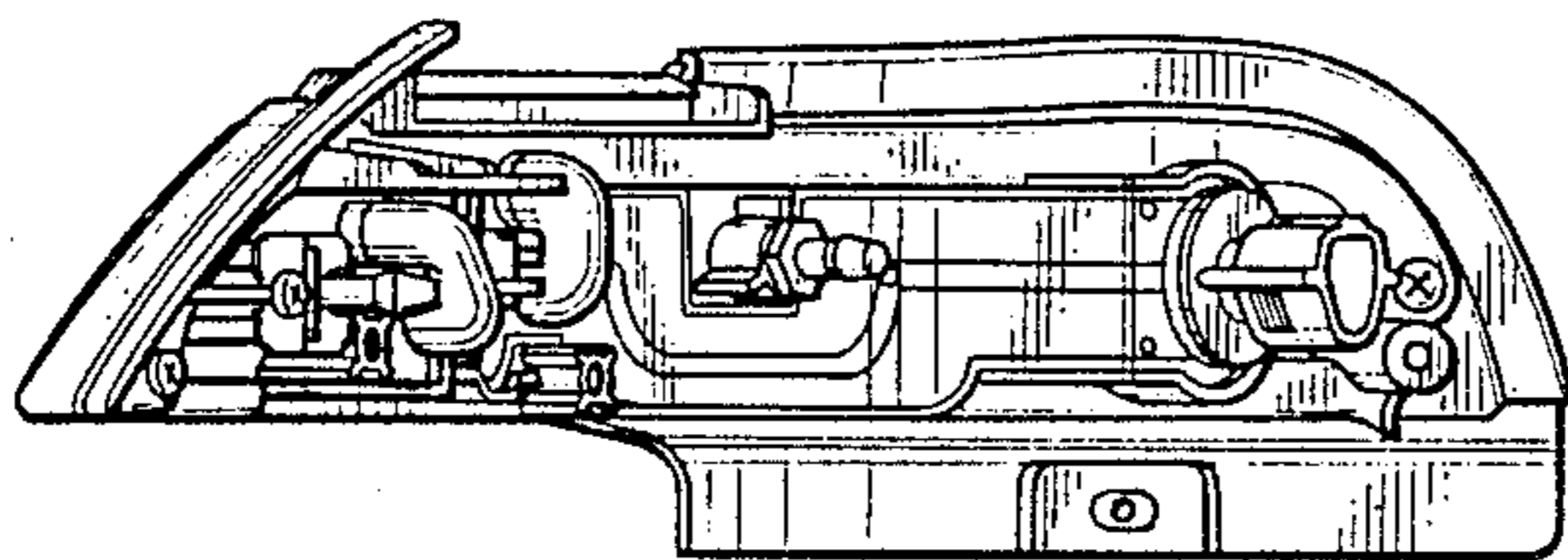

Fig. 8

