

[54] AMPHIBIOUS VEHICLE

[76] Inventor: Bill Price, II, P.O. Box 730,  
Morehead City, N.C. 28557

[\*\*] Term: 14 Years

[21] Appl. No.: 72,853

[22] Filed: Jul. 14, 1987

[52] U.S. Cl. .... D12/3

[58] Field of Search ..... D12/3; 114/270

4,008,679 2/1977 Bozzano ..... 114/270  
4,357,893 11/1982 Frye ..... 114/270  
4,387,661 6/1983 Duff ..... 114/270  
4,459,932 7/1984 Hildebrand ..... 114/270

Primary Examiner—James M. Gandy  
Assistant Examiner—Melody Brown  
Attorney, Agent, or Firm—Bell, Seltzer, Park & Gibson

[57] CLAIM

The ornamental design for an amphibious vehicle, as shown and described.

[56] References Cited

U.S. PATENT DOCUMENTS

D. 230,845	3/1974	Priestley	.....	D12/3
2,376,626	5/1945	Schuller	.....	114/270
2,960,056	11/1960	Puccinelli	.....	114/270
3,180,305	4/1965	Gower-Rempel	.....	114/270
3,199,486	8/1965	Gillois et al.	.....	114/270
3,213,821	10/1965	Godwin	.....	114/270
3,421,472	1/1969	Oberg	.....	114/270
3,575,126	4/1971	Karvonen	.....	114/270
3,595,199	7/1971	Faxas	.....	114/270
3,688,731	9/1972	Houle	.....	114/270
3,765,368	10/1973	Asbeck	.....	114/270
3,895,596	7/1975	Amour	.....	114/270

DESCRIPTION

FIG. 1 is a perspective view of an amphibious vehicle showing my new design;  
FIG. 2 is a side elevational view thereof;  
FIG. 3 is a front elevational view thereof;  
FIG. 4 is a rear elevational view thereof;  
FIG. 5 is a top plan view thereof;  
FIG. 6 is a perspective view of an amphibious vehicle showing a second embodiment of my new design;  
FIG. 7 is a side elevational view of FIG. 6;  
FIG. 8 is a front elevational view of FIG. 6;  
FIG. 9 is a rear elevational view of FIG. 6; and  
FIG. 10 is a top plan view of FIG. 6.

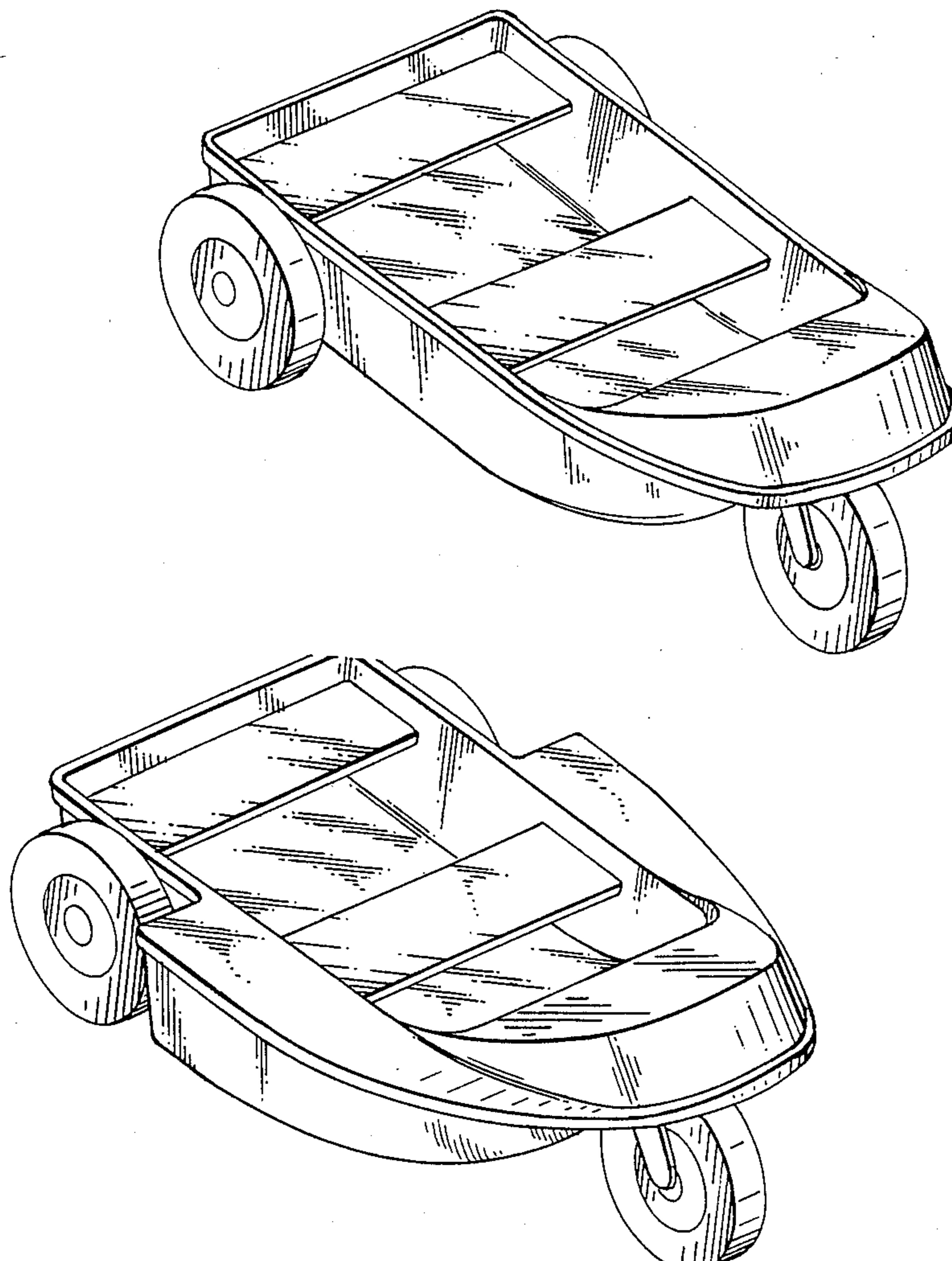

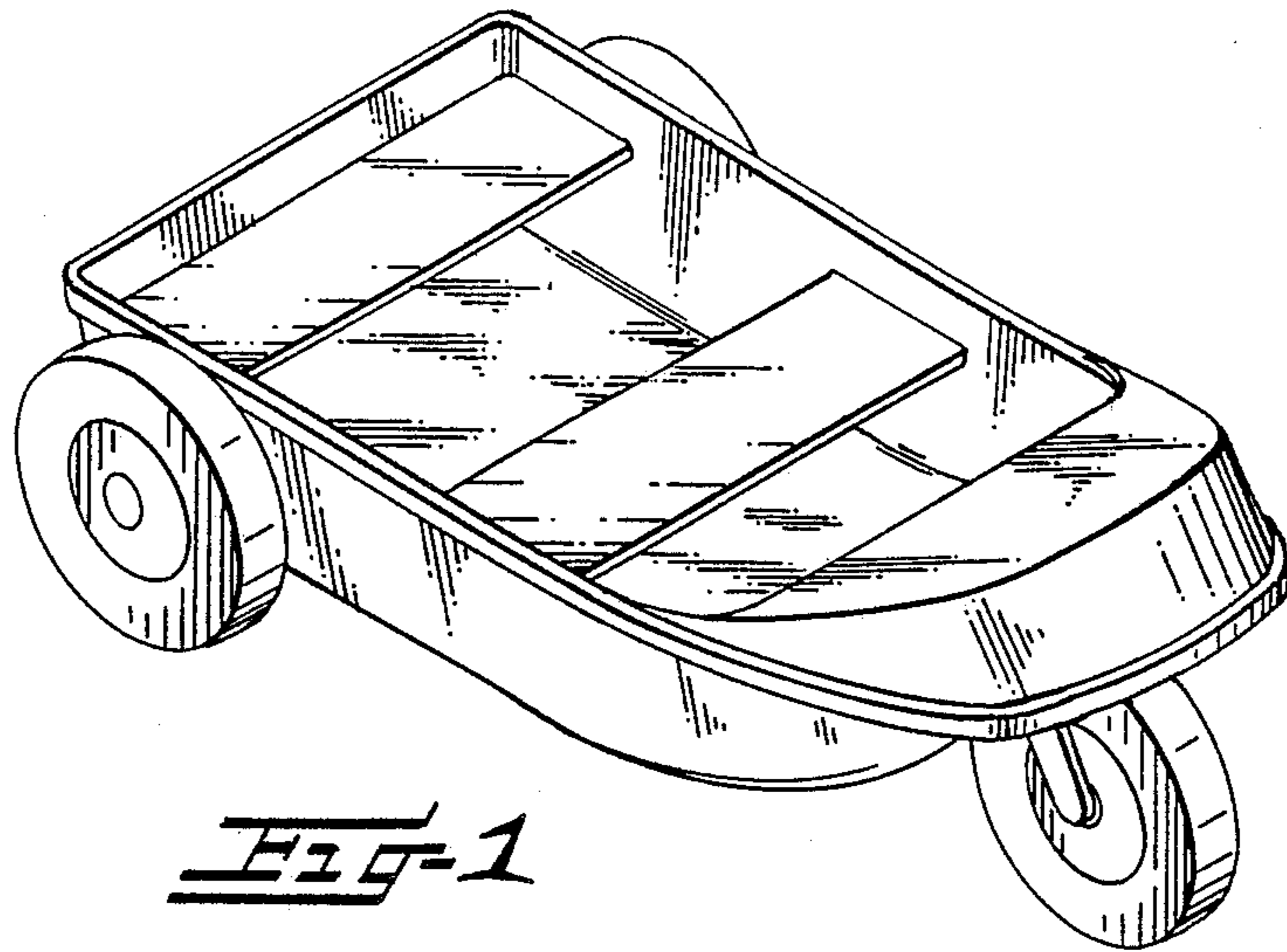

Fig-1

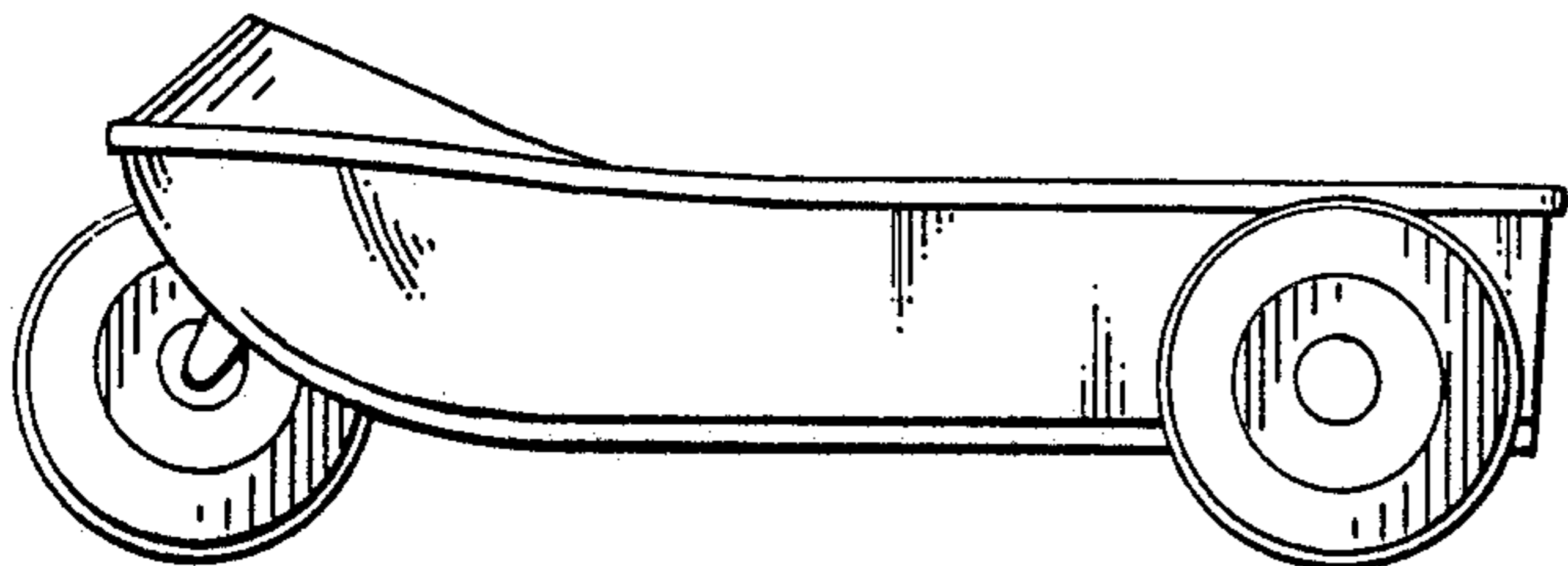

Fig-2

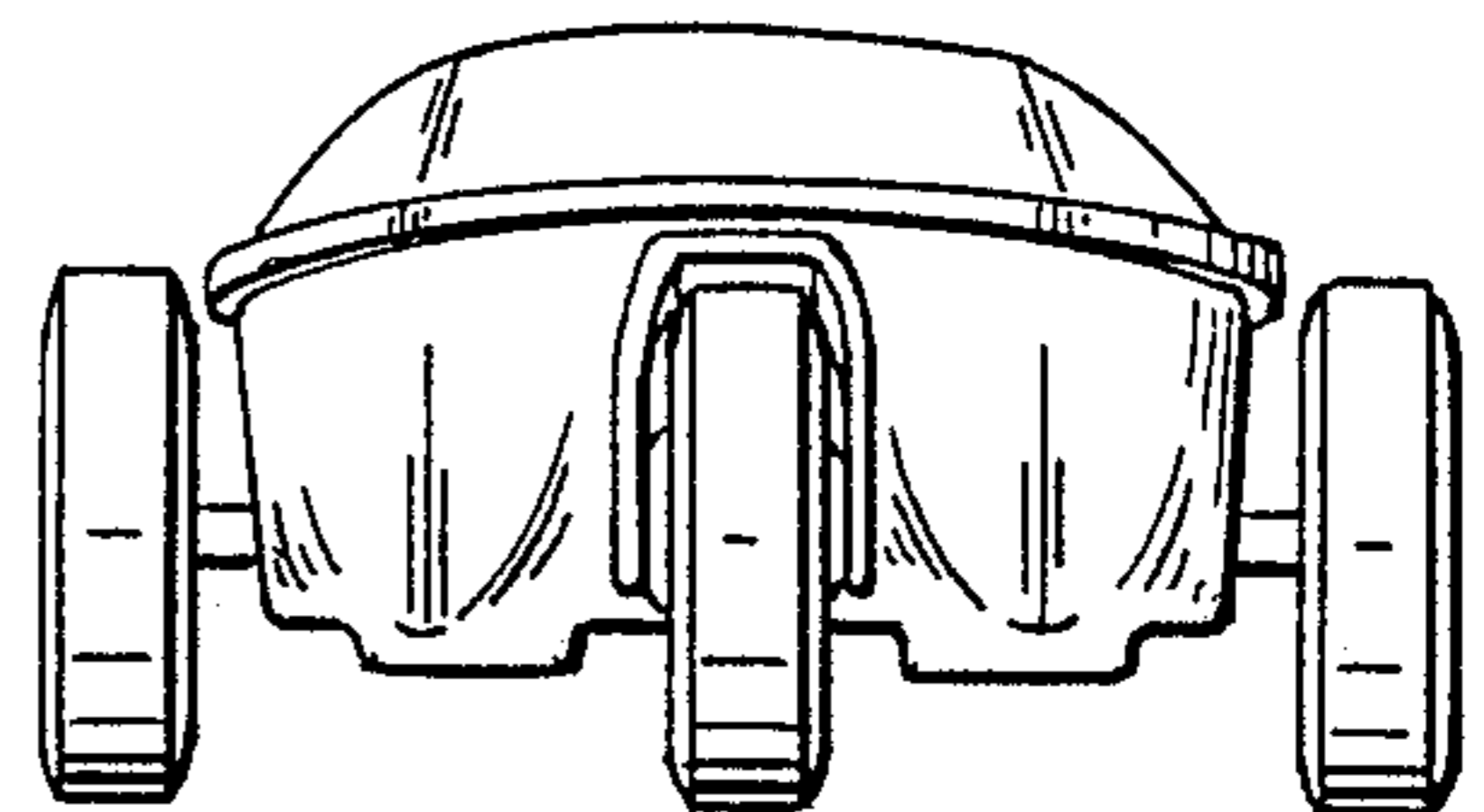

Fig-3

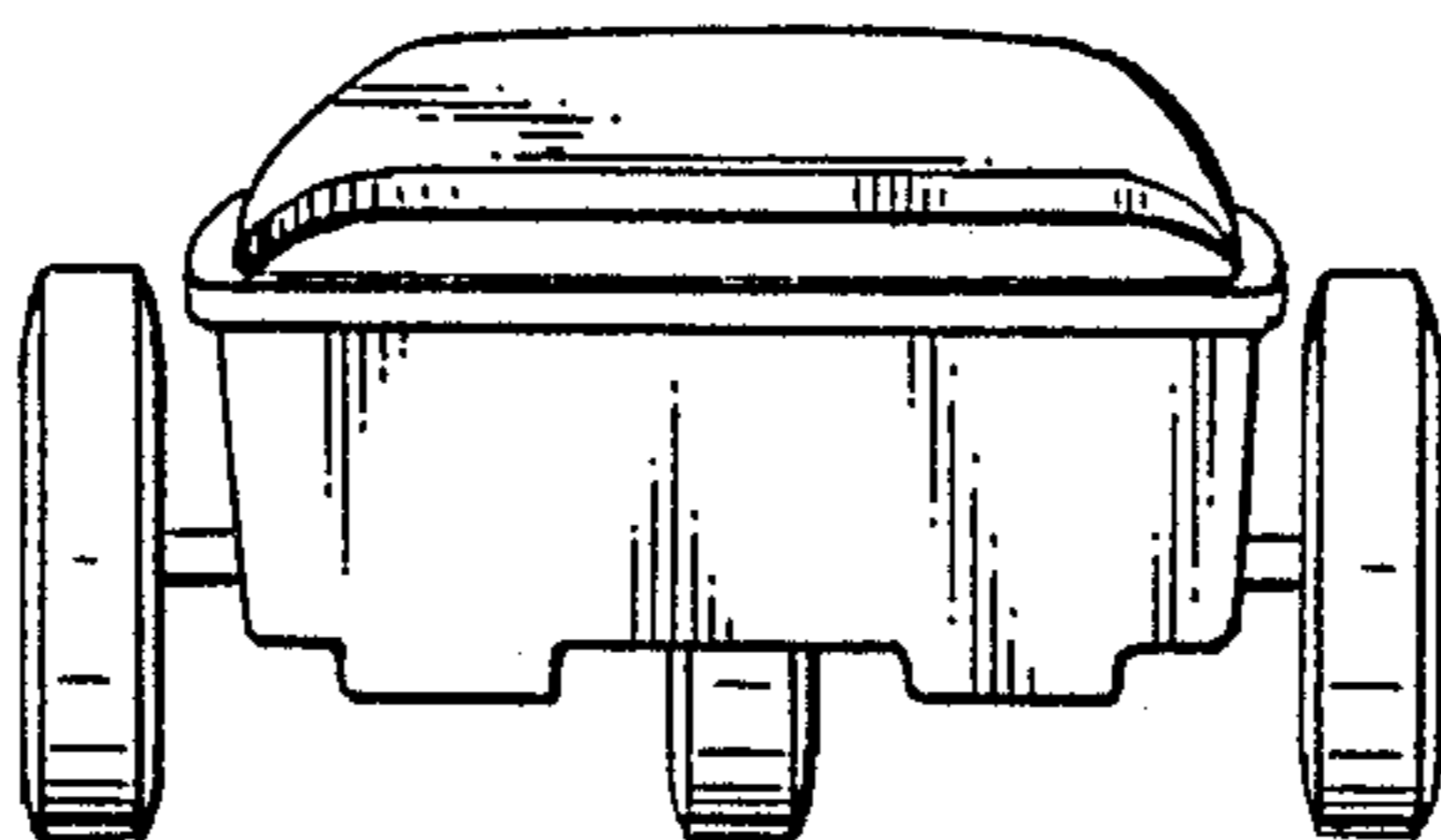

Fig-4

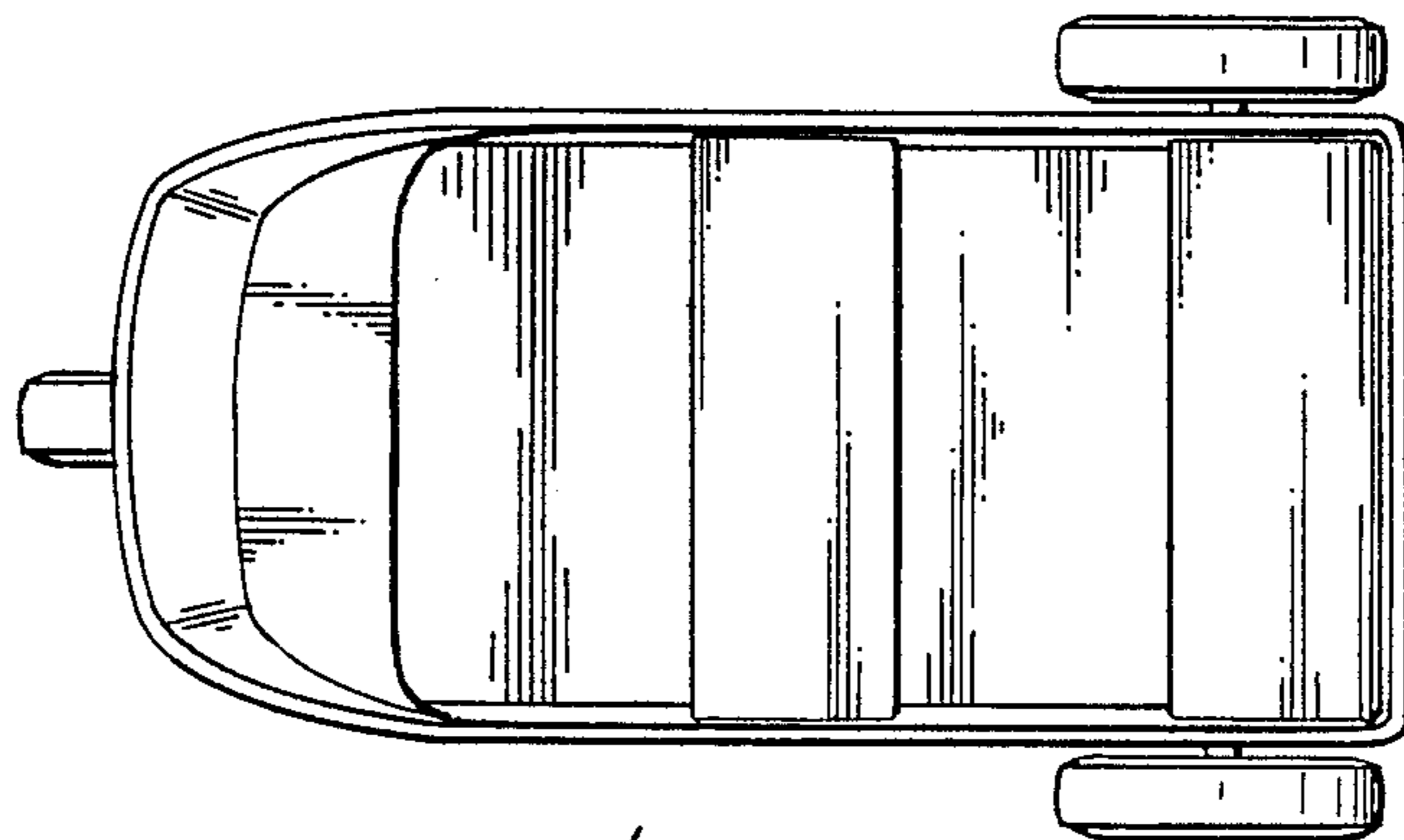

Fig-5

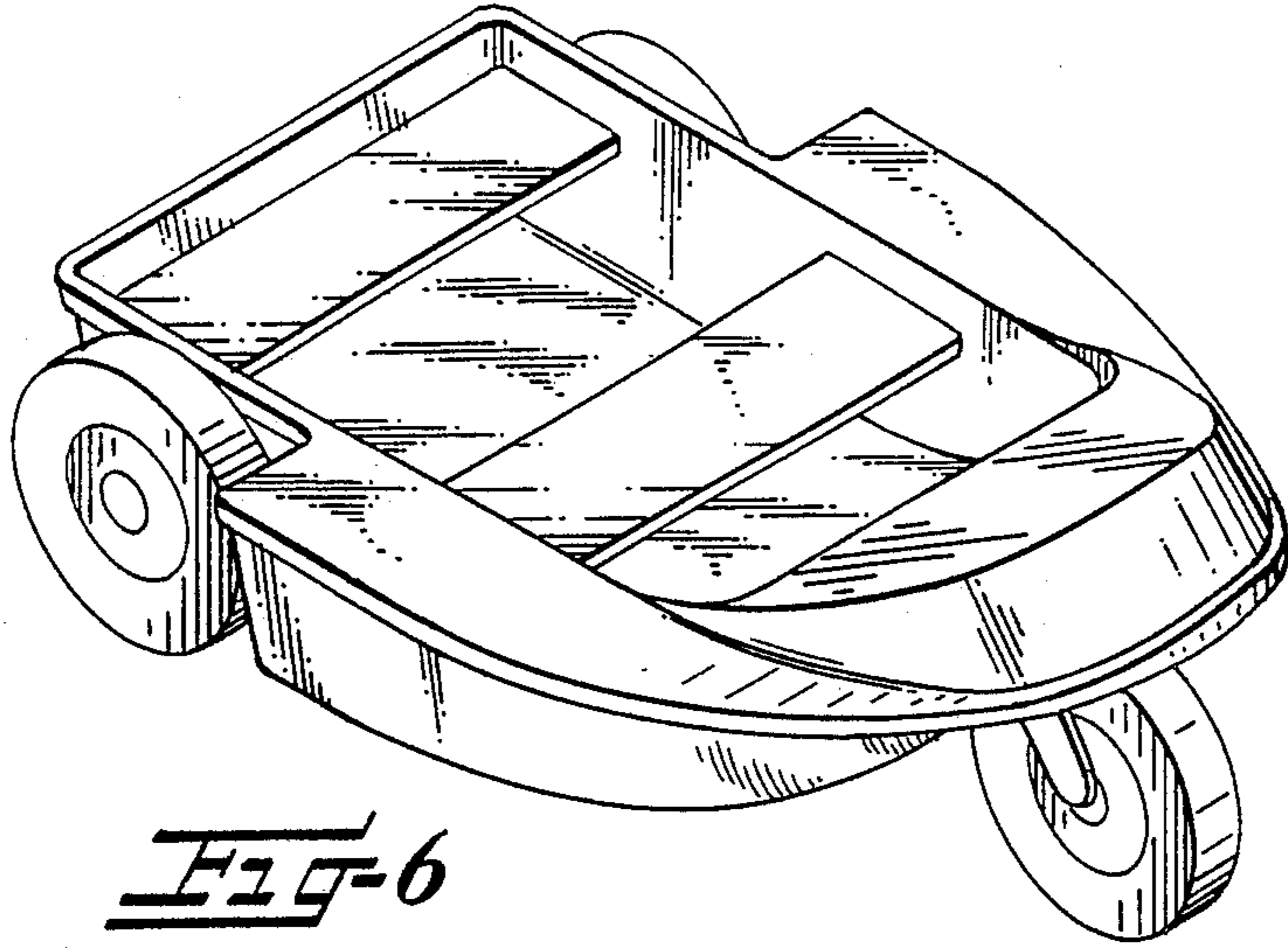

Fig-6

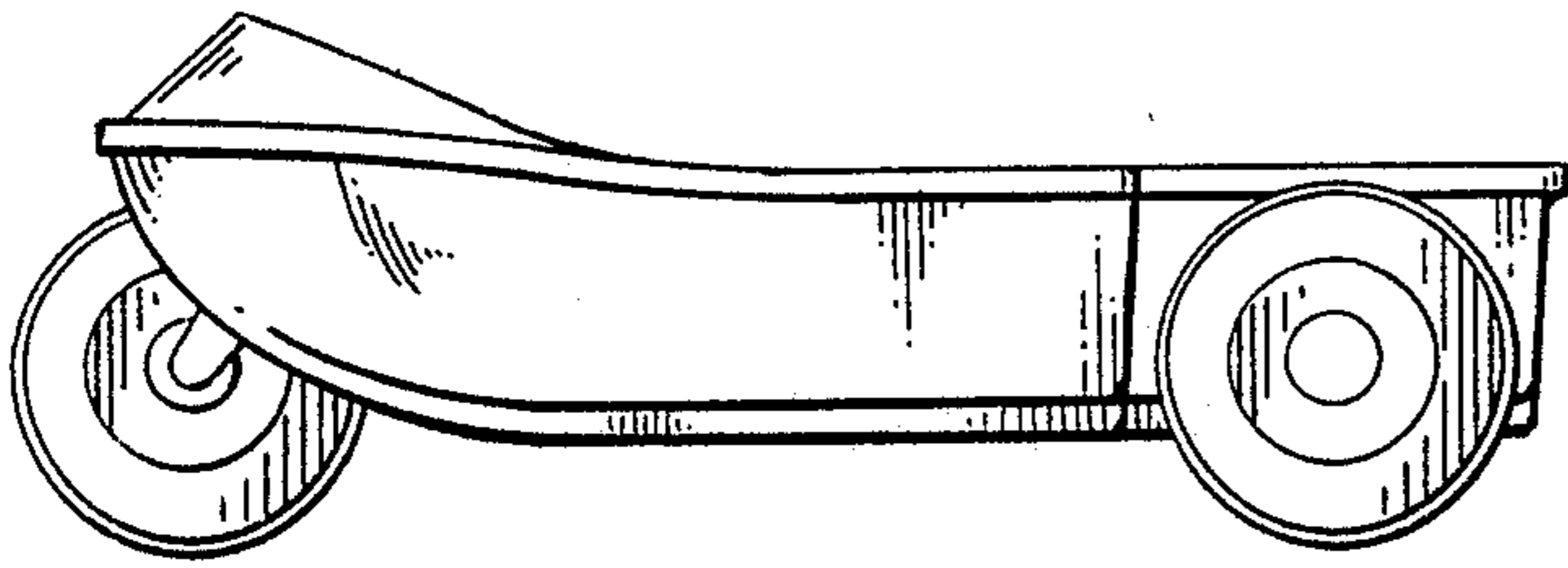

Fig-7

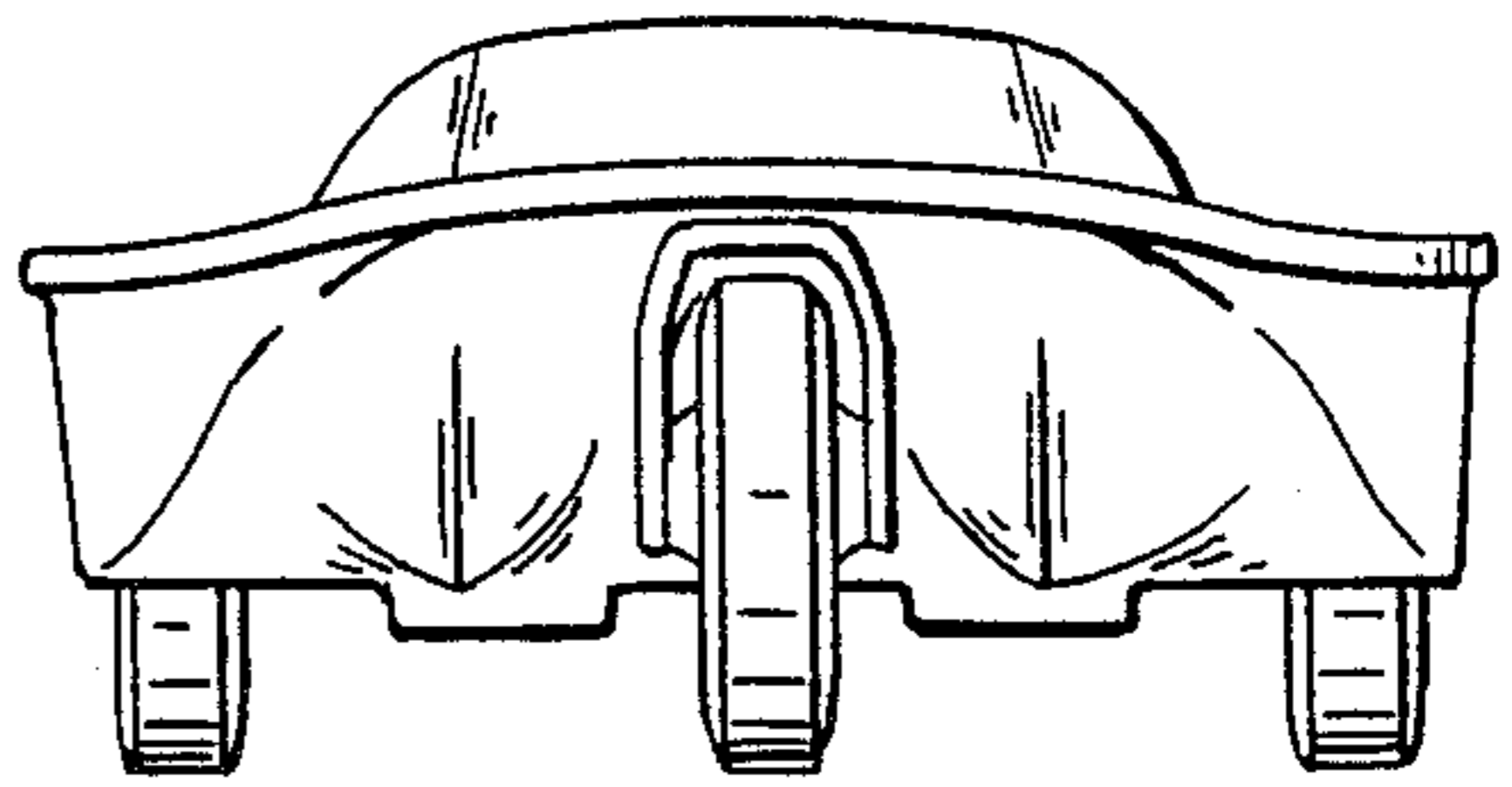

Fig-8

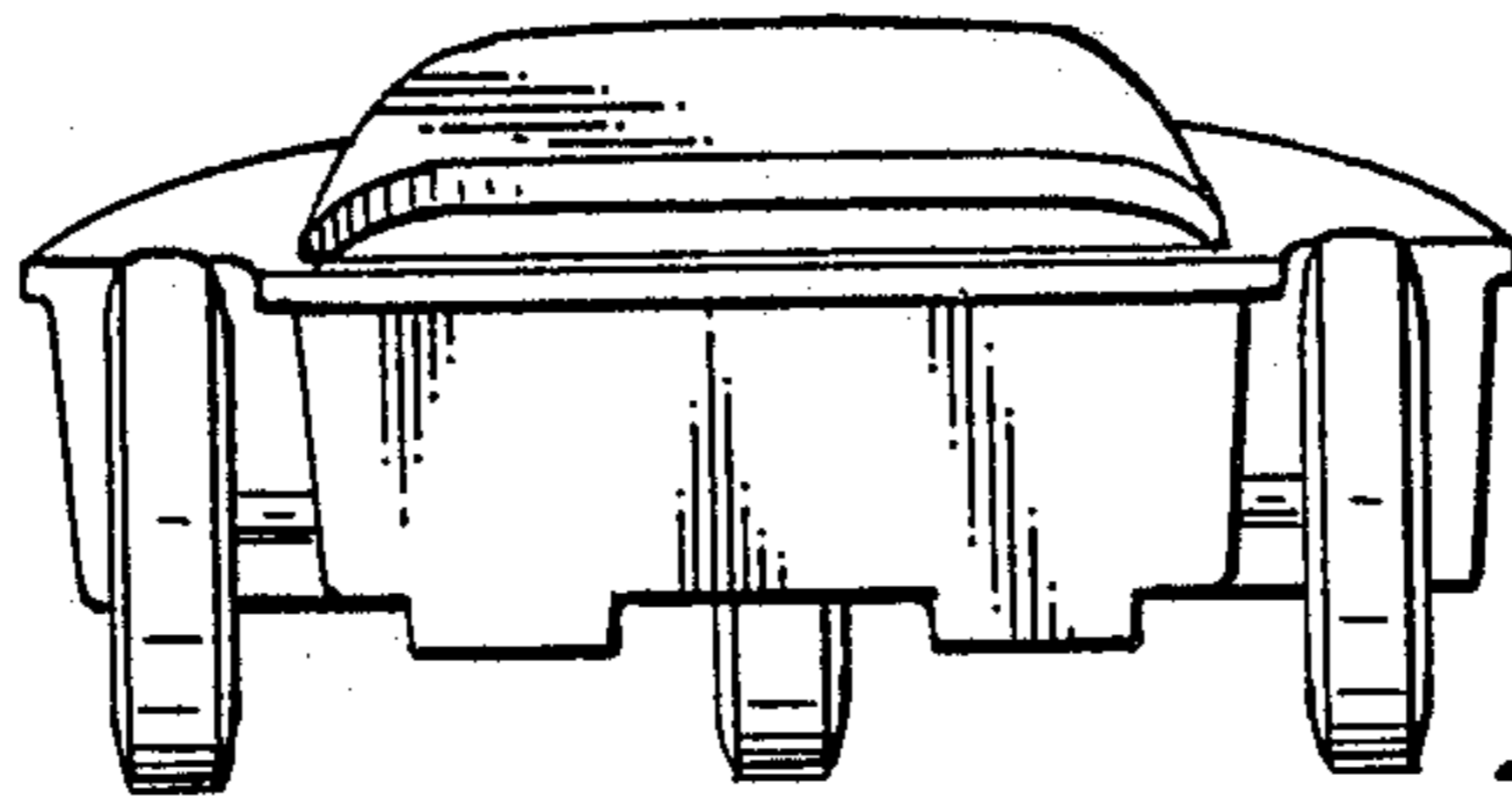

Fig-9

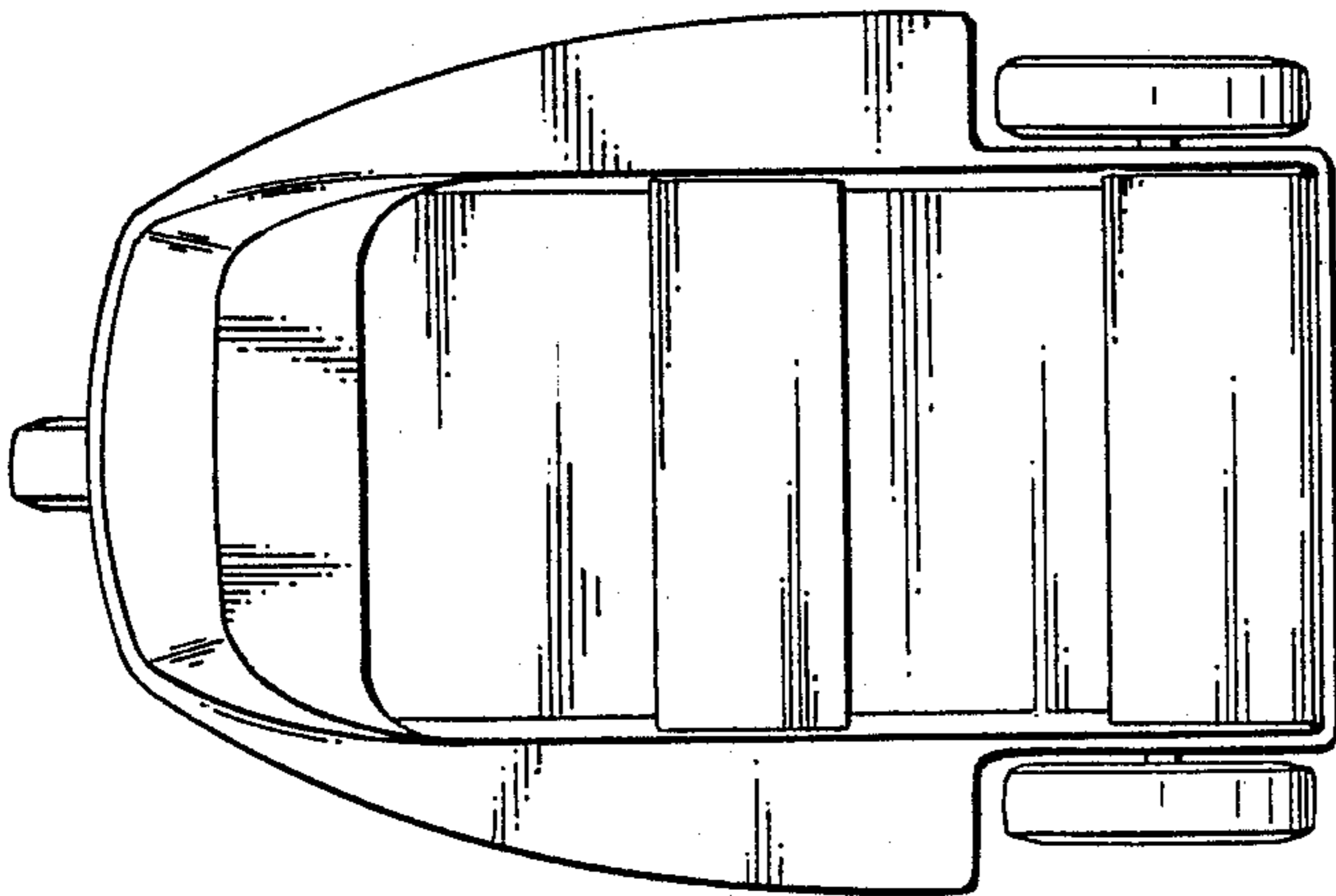

Fig-10