

[54] MERCHANDISING DISPLAY FRAME

[75] Inventors: Fred Howard, New York; Sydney Edson, East Meadow, both of N.Y.

[73] Assignee: Sara Lee Corporation, Winston-Salem, N.C.

[**] Term: 14 Years

[21] Appl. No.: 39,378

[22] Filed: Apr. 17, 1987

[52] U.S. Cl. D6/462

[58] Field of Search D6/396, 397, 449, 462; 211/189

[56] References Cited

U.S. PATENT DOCUMENTS

2,971,805	2/1961	Weiss	211/134 X
4,611,866	9/1986	Everett	211/189 X
4,705,175	11/1987	Howard et al.	211/59.1 X
4,762,235	8/1988	Howard et al.	211/126 X

Primary Examiner—Carmen H. Vales-Lado
Assistant Examiner—Schon C. Oppert
Attorney, Agent, or Firm—Darby & Darby

[57] CLAIM

The ornamental design for a merchandising display frame, as shown and described.

DESCRIPTION

FIG. 1 is a top perspective view of a merchandising display frame showing our new design; FIG. 2 is a front elevational view thereof; FIG. 3 is a left side elevational view, the right side view being a mirror image thereof; FIG. 4 is a rear elevational view thereof; FIG. 5 is a top plan view thereof; FIG. 6 is a bottom plan view thereof; FIG. 7 is a perspective view of another embodiment of the merchandising display frame shown in FIG. 1, the opposite side being a mirror image thereof; FIG. 8 is a front elevational view thereof; and FIG. 9 is a left side elevational view, the right side view being a mirror image thereof.

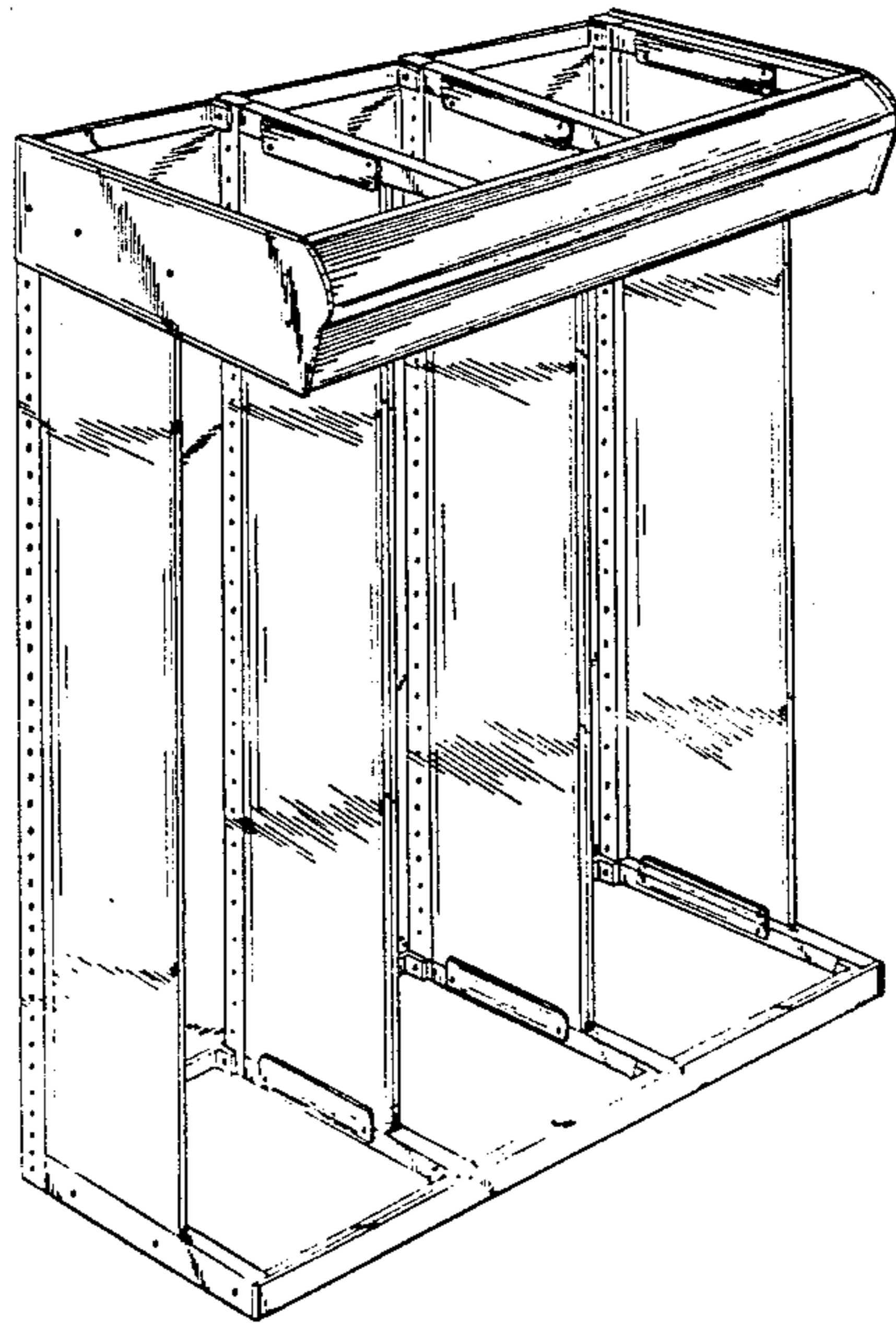
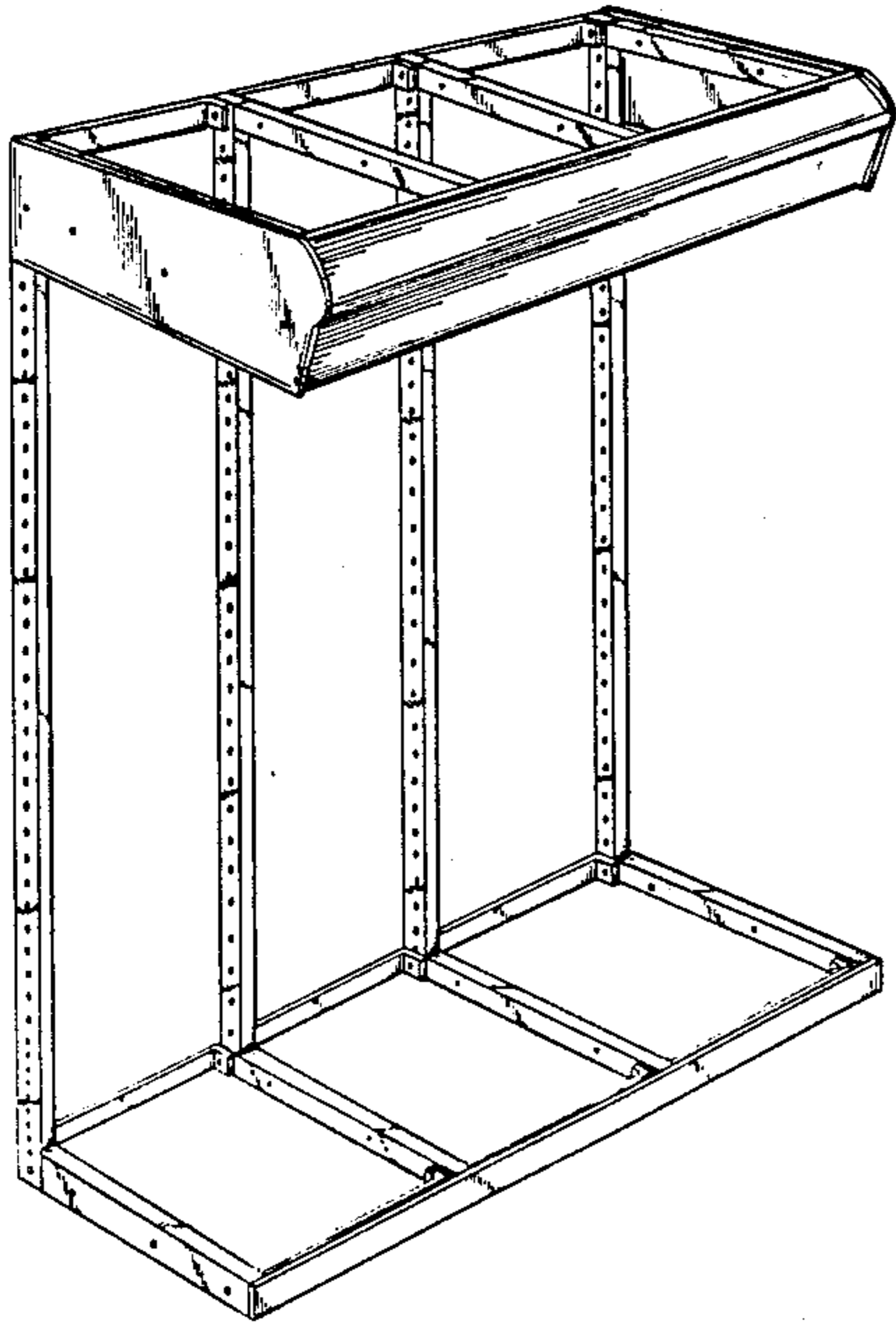

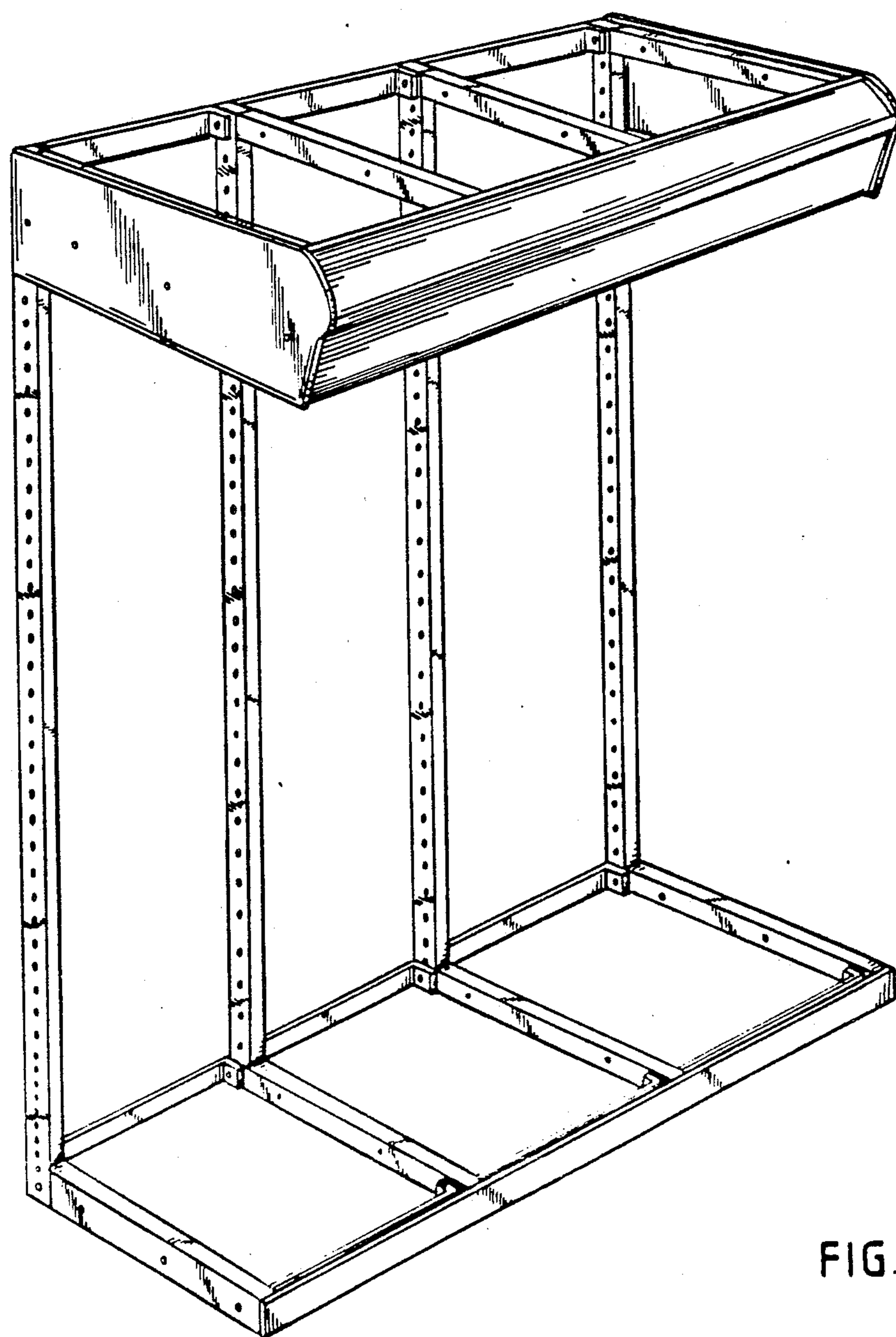

FIG. 1

FIG. 5

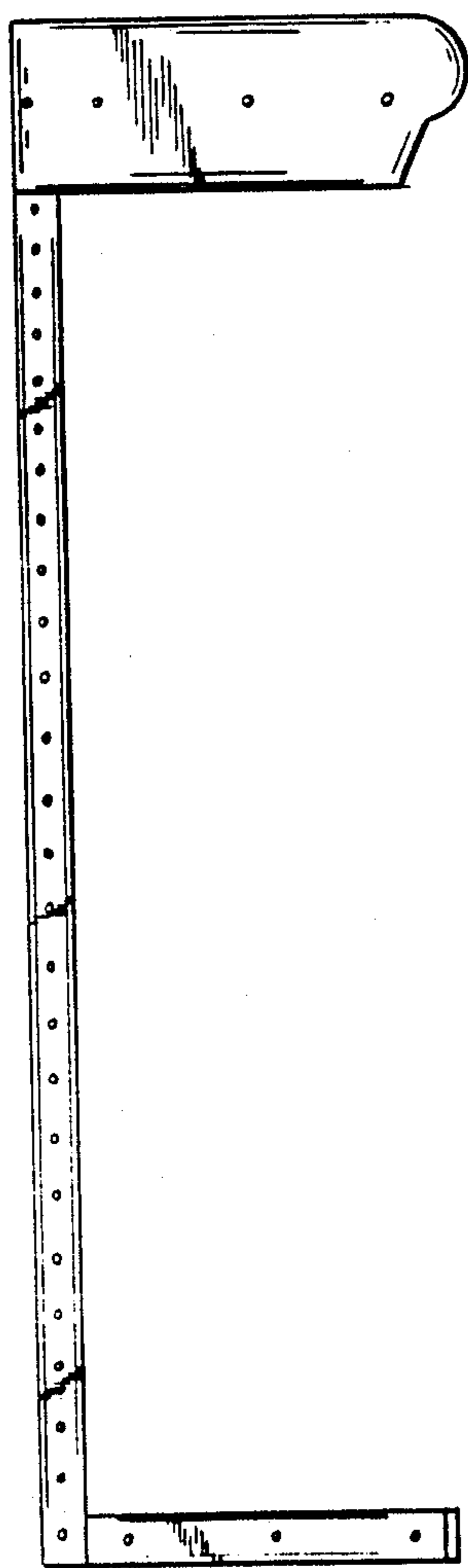
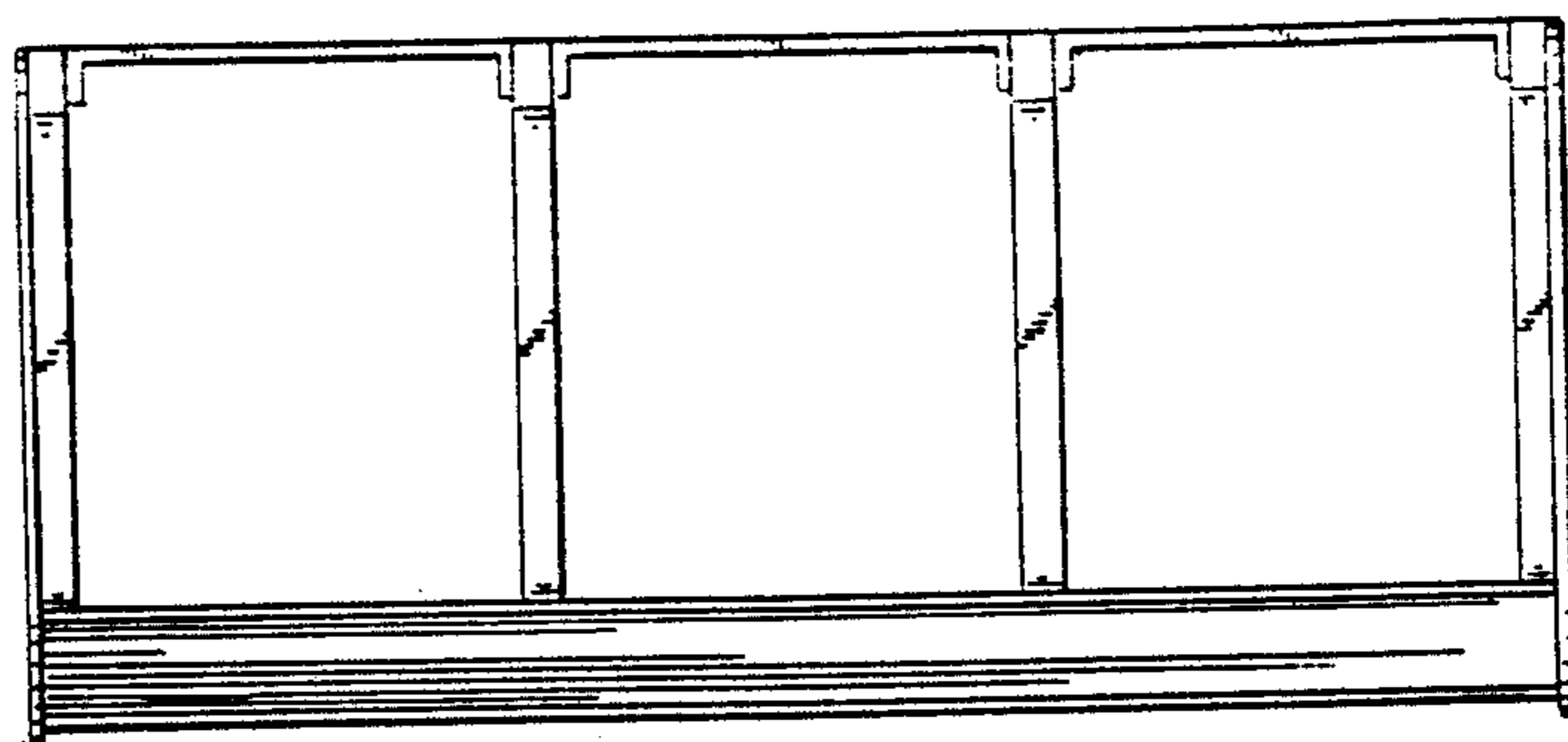

FIG. 3

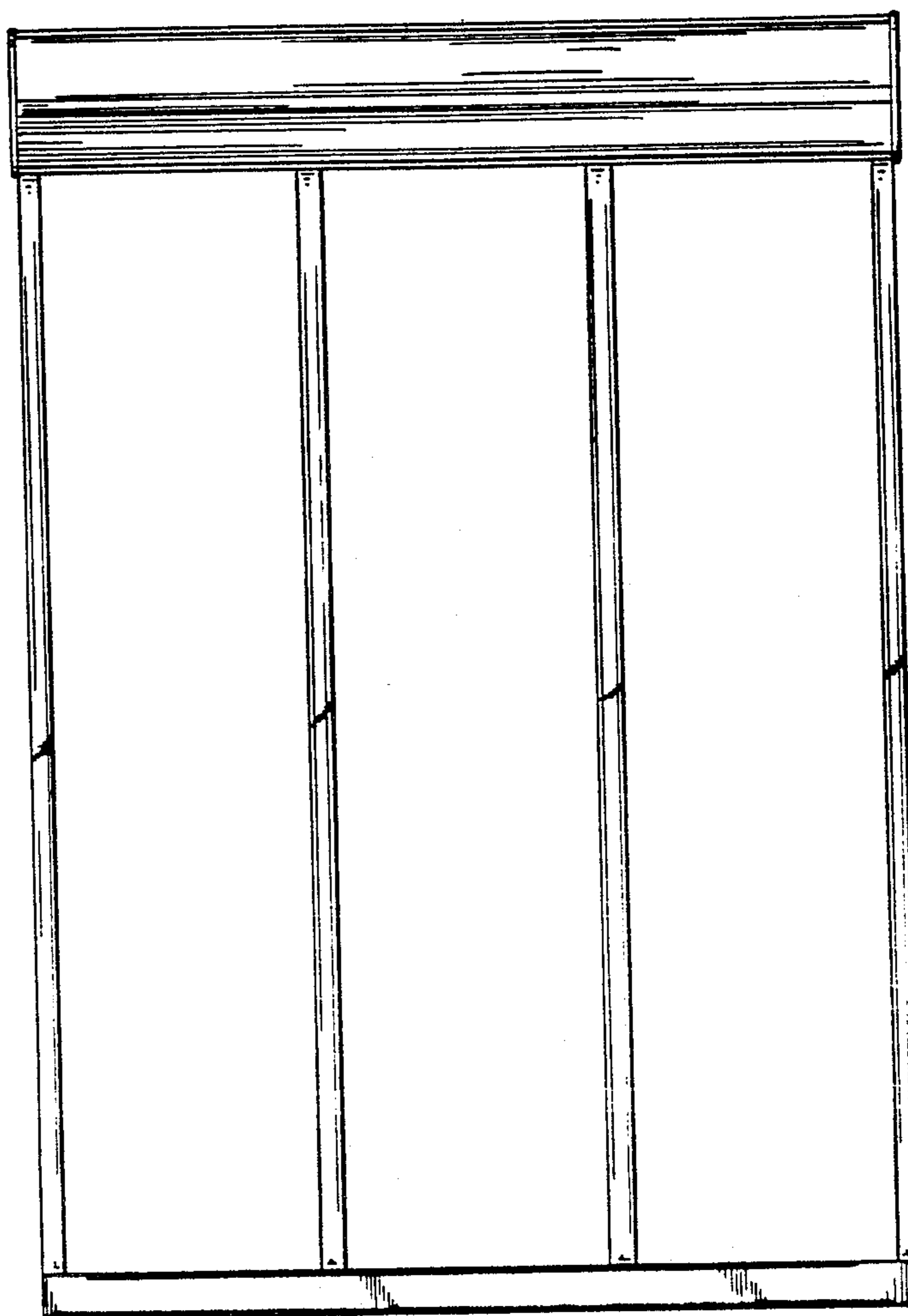

FIG. 2

FIG. 6

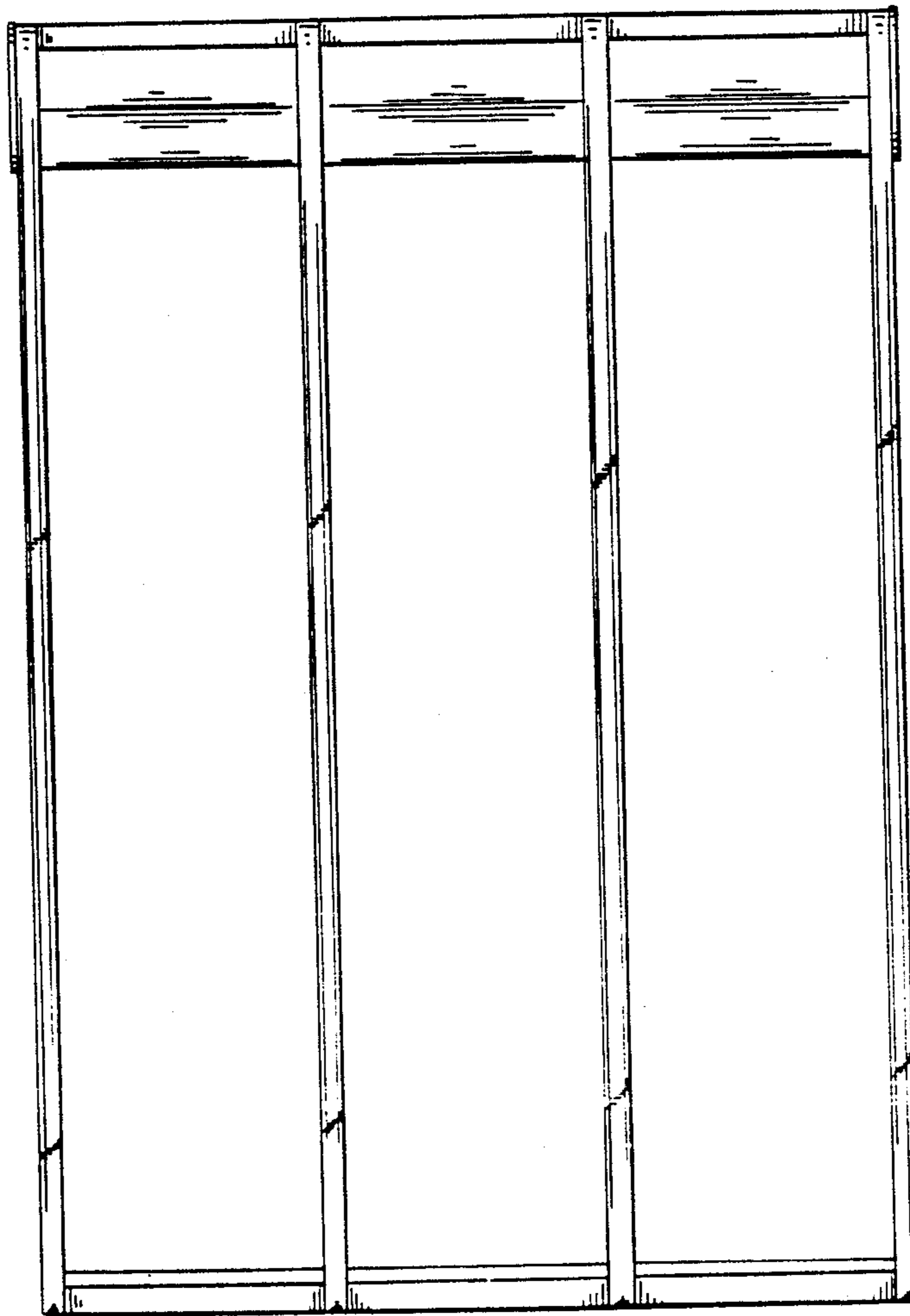
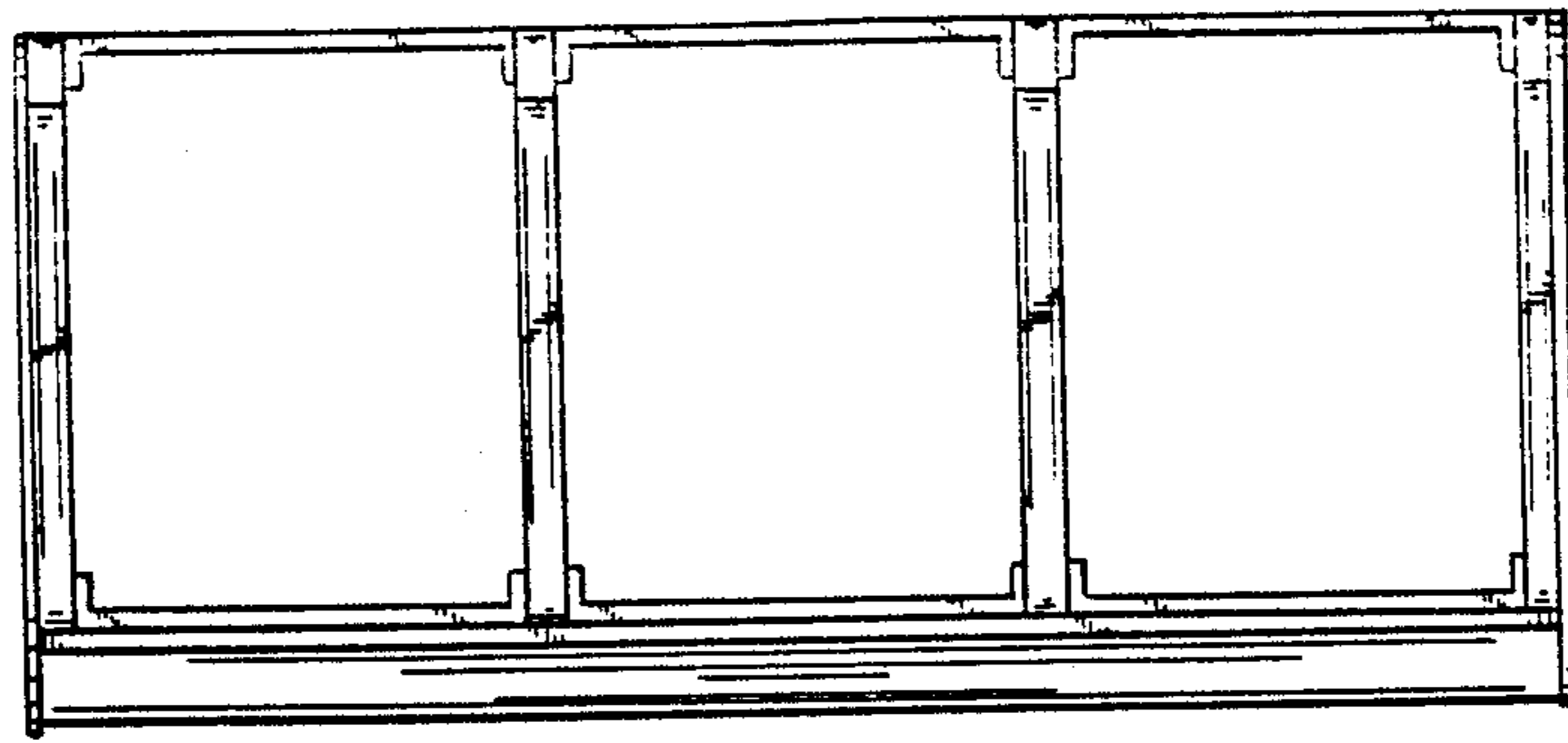

FIG. 4

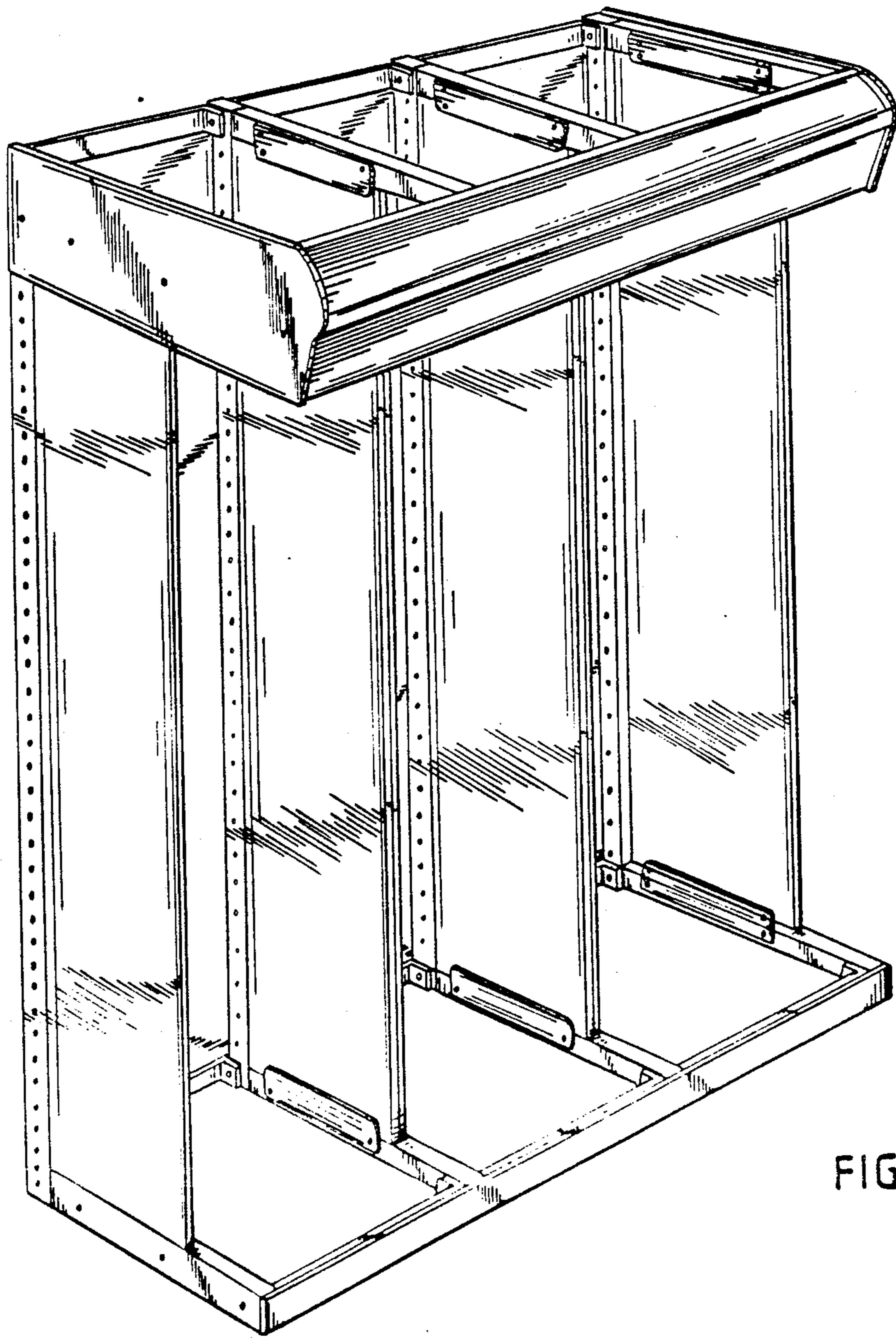

FIG. 7

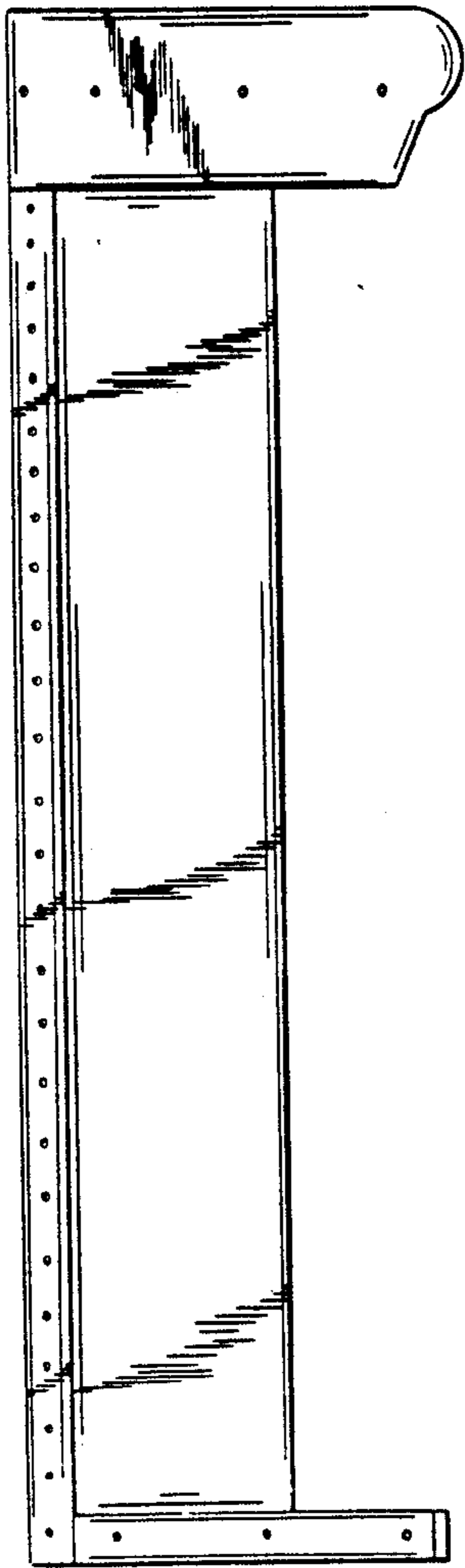

FIG. 9

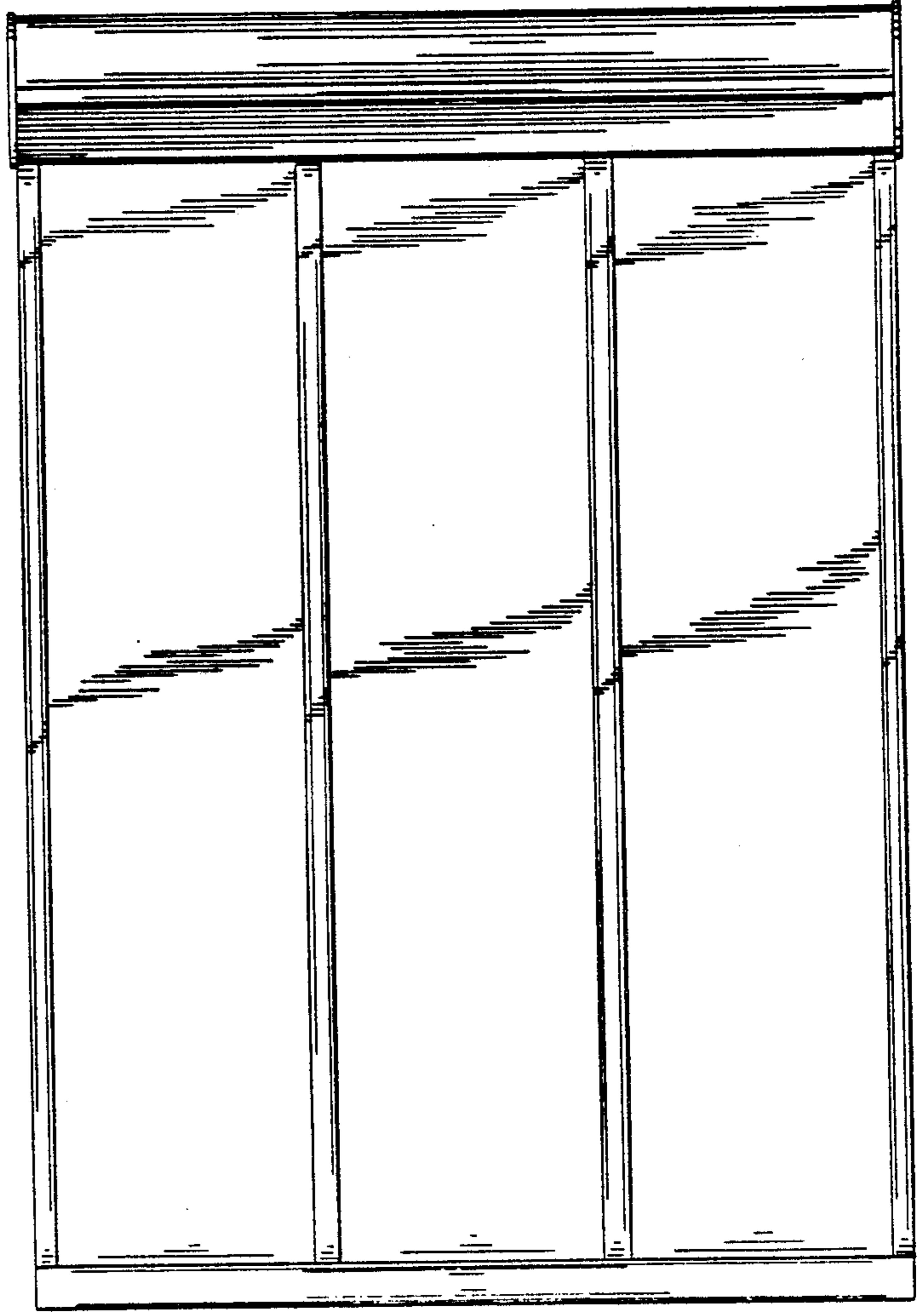

FIG. 8