

[54] SAIL BOAT

4,823,717 4/1989 Roberson ..... 114/61

[75] Inventor: Robert F. Roberson, San Clemente, Calif.

Primary Examiner—Wallace R. Burke  
Assistant Examiner—Kay H. Chin  
Attorney, Agent, or Firm—Morland C. Fischer

[73] Assignee: Hot Sports, Inc., Newport Beach, Calif.

[57] CLAIM

[\*\*] Term: 14 Years

The ornamental design for a sail boat, as shown and described.

[21] Appl. No.: 93,871

DESCRIPTION

[22] Filed: Sep. 8, 1987

[52] U.S. Cl. .... D12/304; D12/303

[58] Field of Search ..... D12/300, 304, 303;  
114/61, 39.1, 39.2

FIG. 1 is a side elevational view of a sail boat showing my new design, the opposite side elevational view being a mirror image of that shown;

FIG. 2 is a top plan view thereof taken along lines 2—2 of FIG. 1;

FIG. 3 is a bottom plan view thereof;

FIG. 4 is a front elevational view thereof taken along lines 4—4 of FIG. 1; and

FIG. 5 is a rear elevational view thereof taken along lines 5—5 of FIG. 1.

[56] References Cited

U.S. PATENT DOCUMENTS

D. 224,606	8/1972	Alter	.....	D12/304
D. 274,237	6/1984	Edmonds et al.	.....	D12/304
3,812,805	5/1974	Forssell et al.	.....	114/61

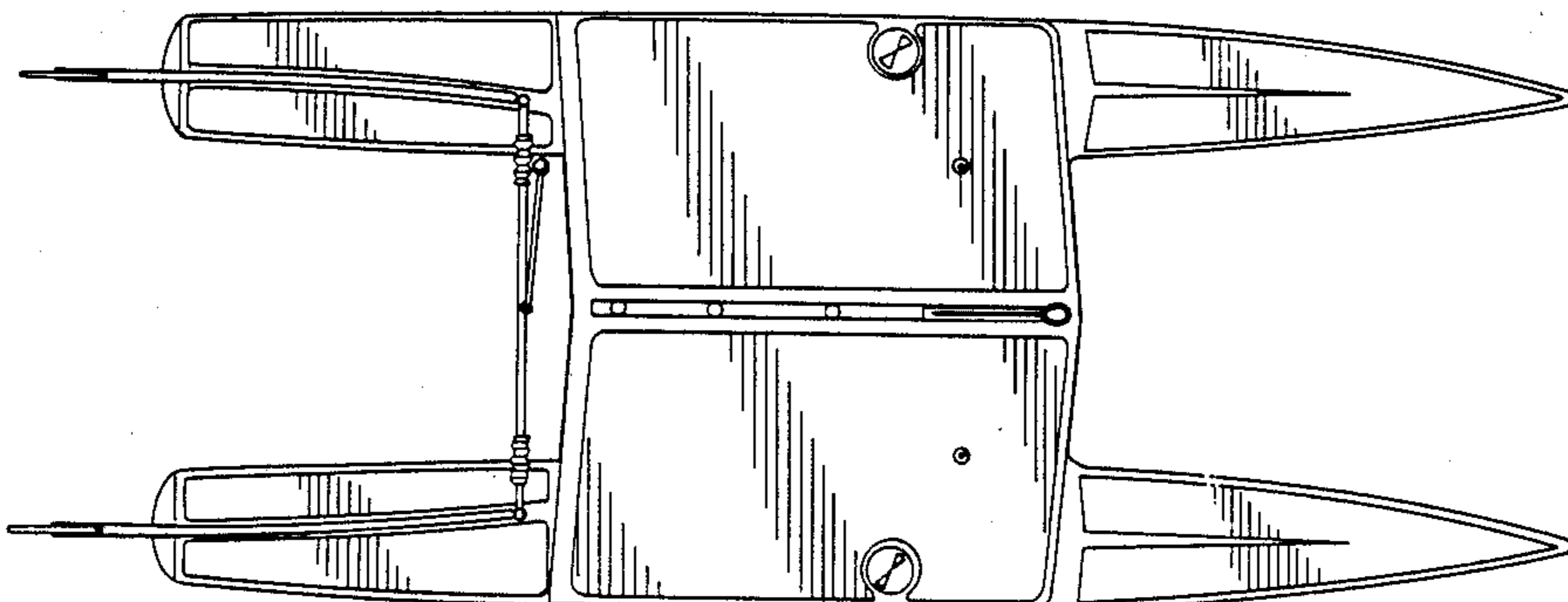
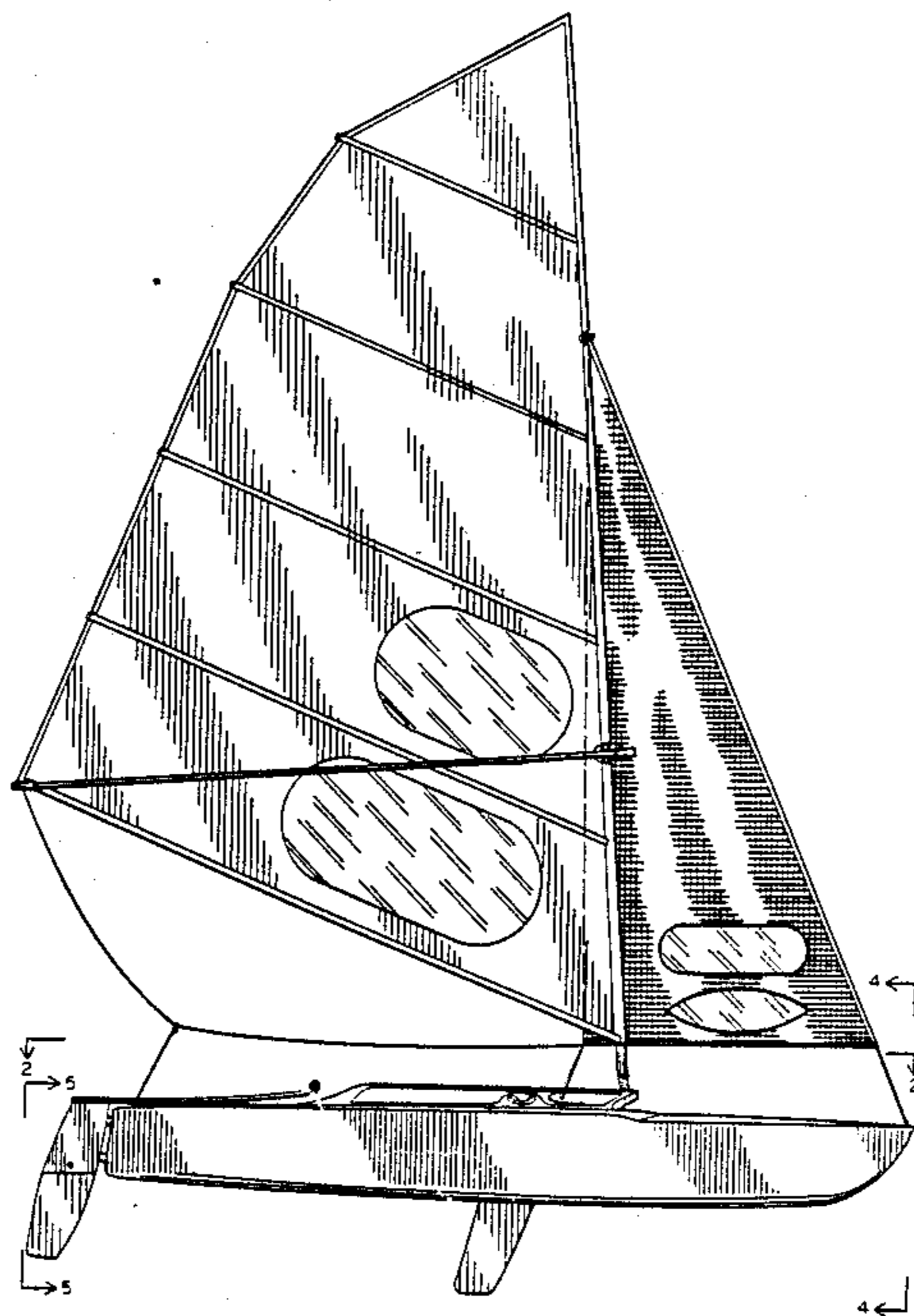

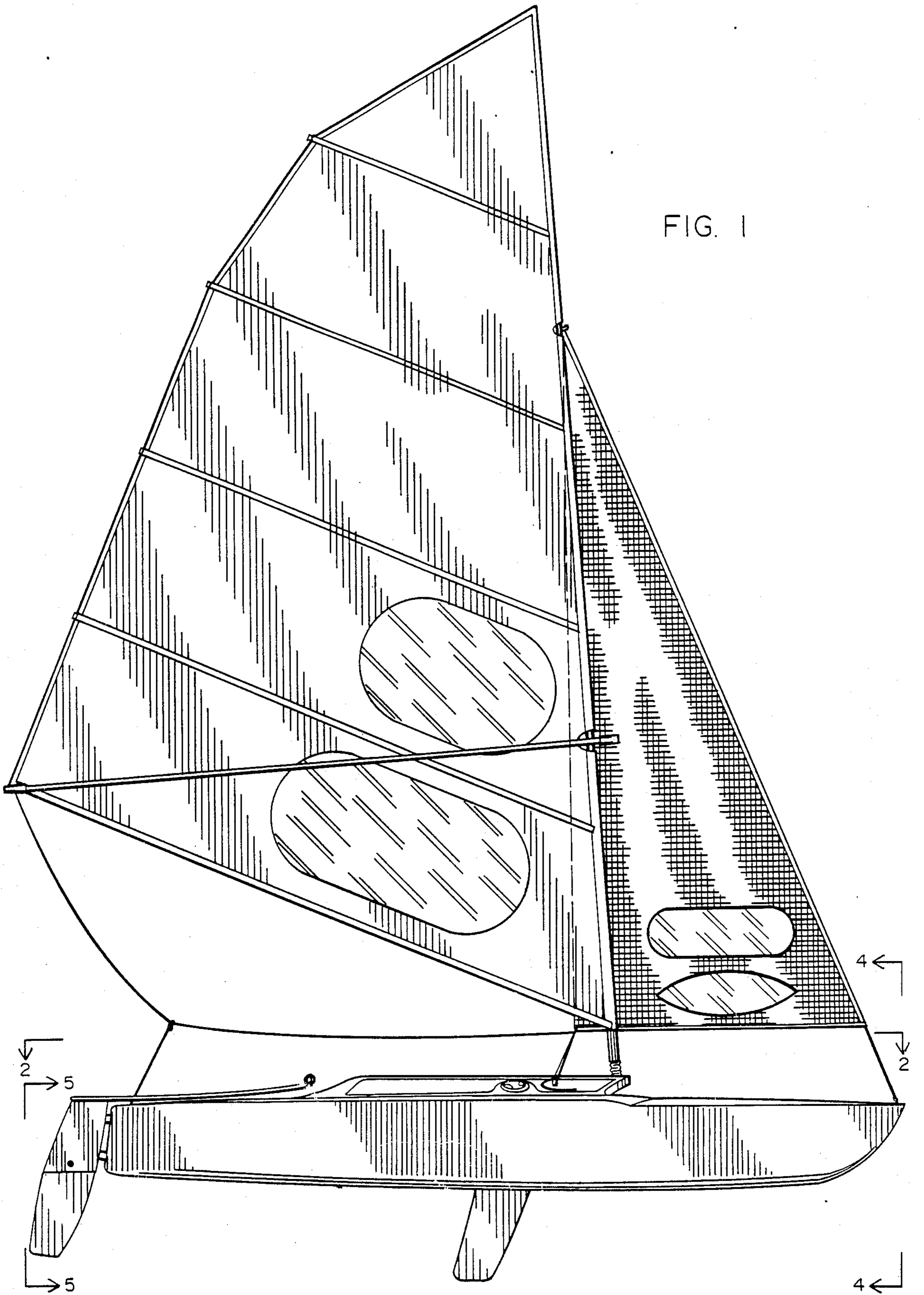

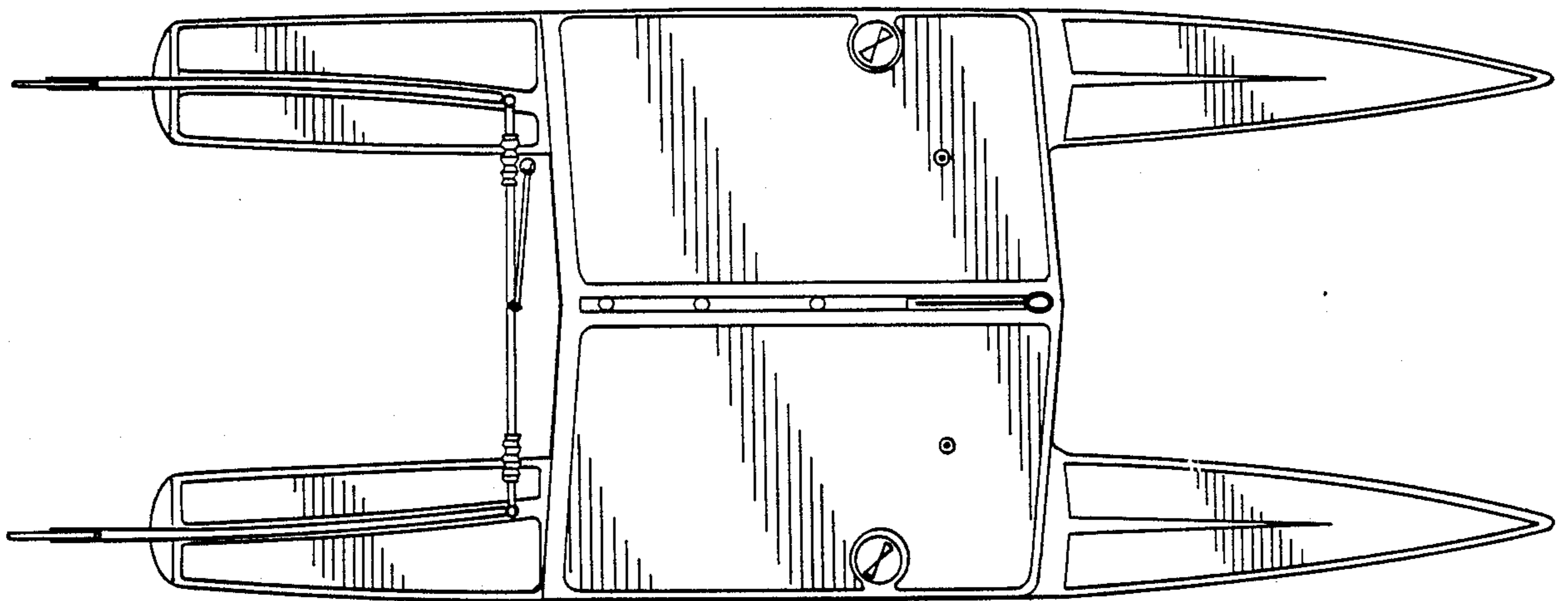

FIG. 2

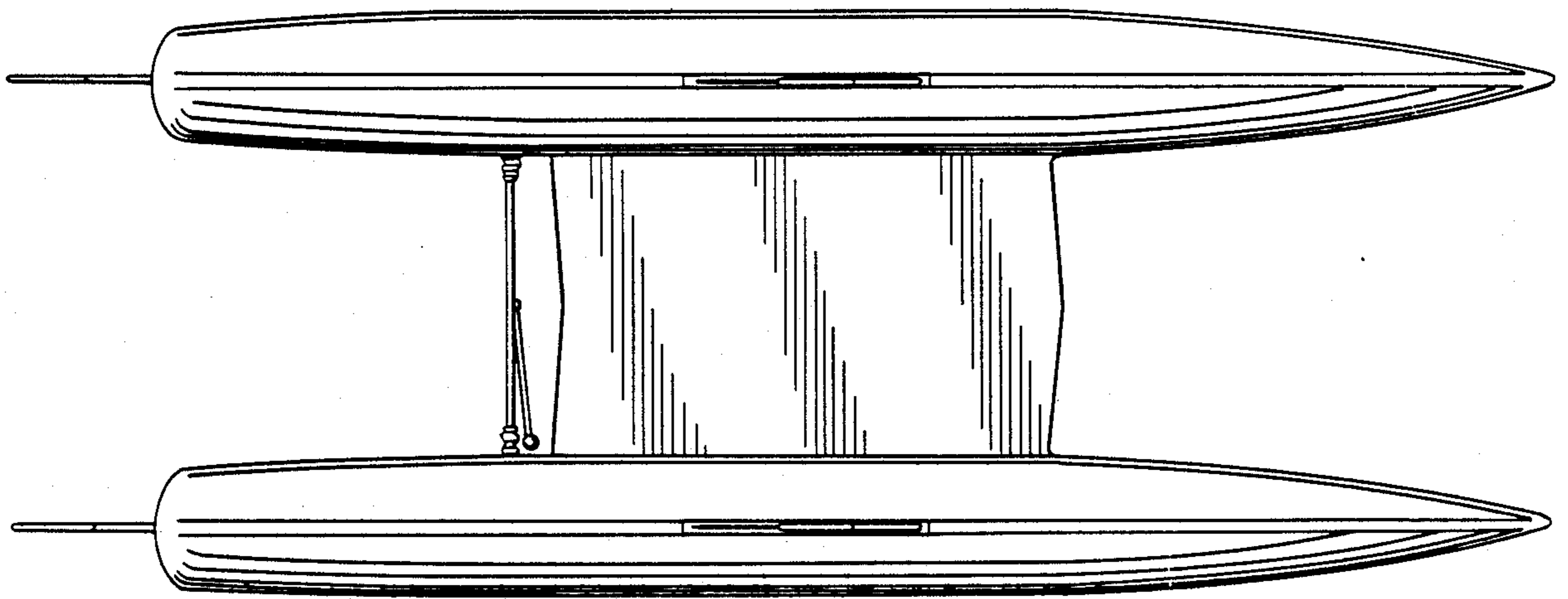

FIG. 3

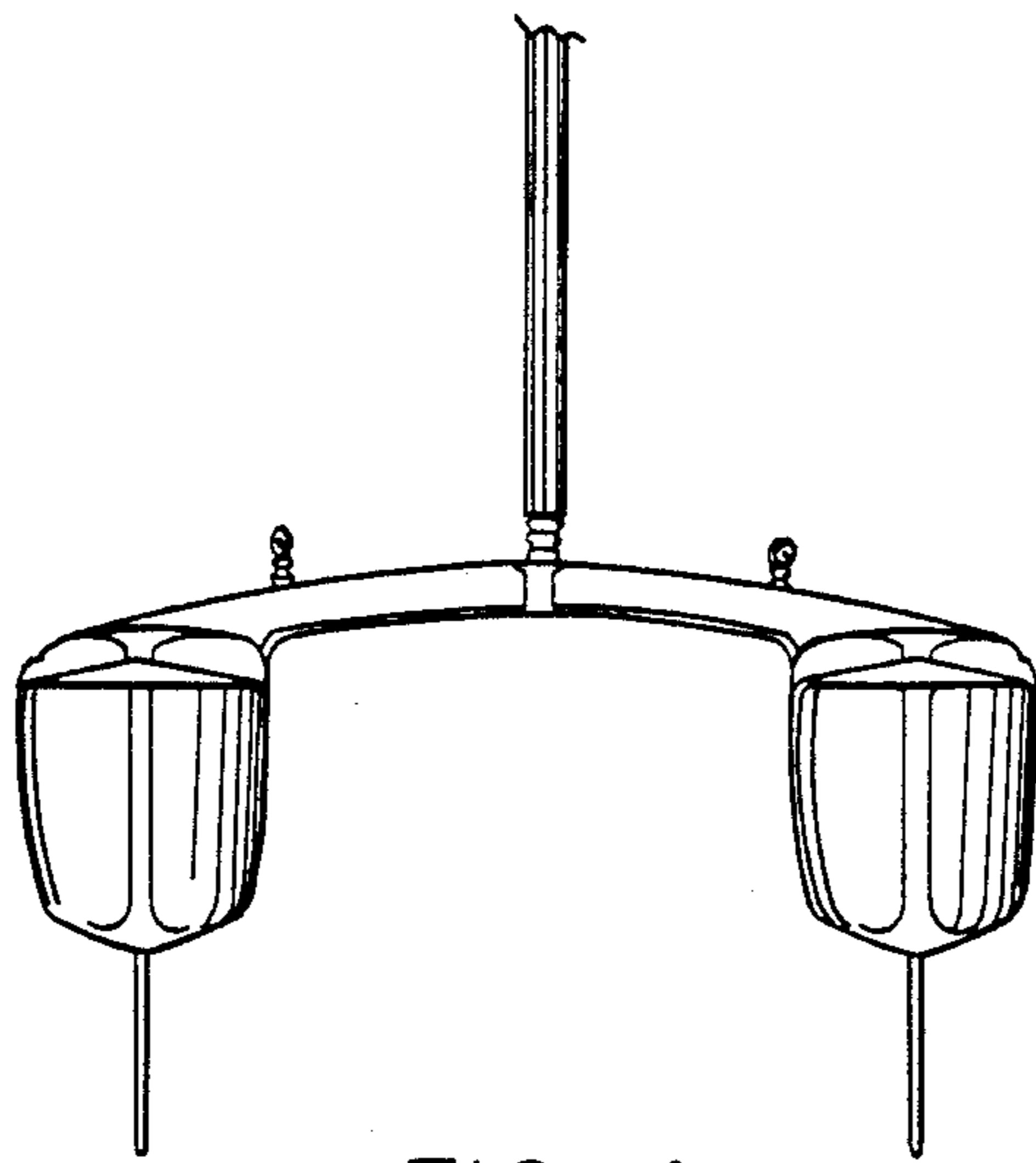

FIG. 4

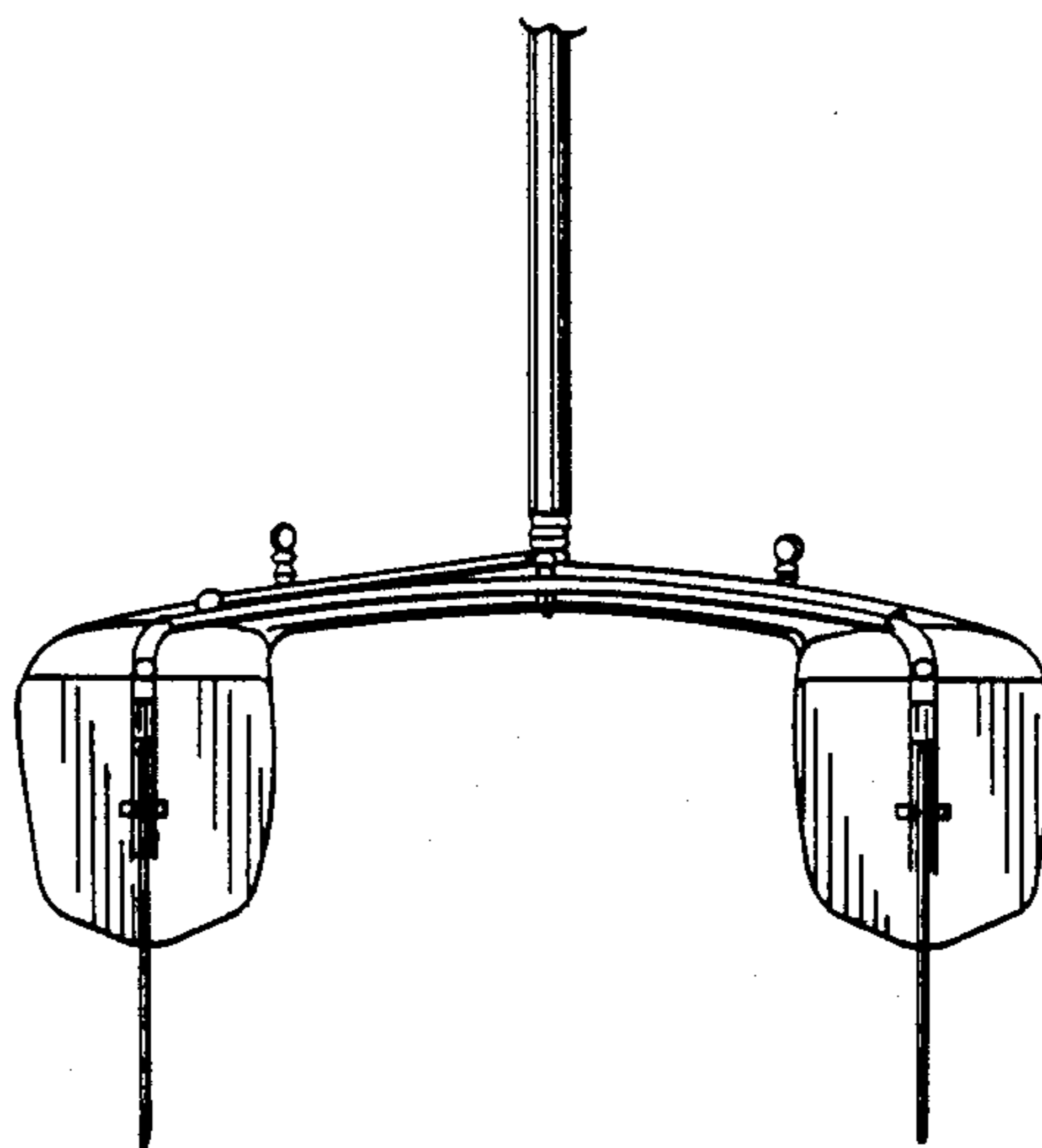

FIG. 5