

[54] SELF-PROPELLED THREE WHEELED VEHICLE

[75] Inventor: Osamu Hayata, Iwata, Japan

[73] Assignee: Yamaha Hatsudoki Kabushiki Kaisha, Japan

[\*\*] Term: 14 Years

[21] Appl. No.: 946,281

[22] Filed: Dec. 23, 1986

[30] Foreign Application Priority Data

Jun. 28, 1986 [JP] Japan ..... 61-25295  
Jun. 28, 1986 [JP] Japan ..... 61-25296

[52] U.S. Cl. .... D12/85

[58] Field of Search ..... D12/85; 180/215, 216, 180/211, 907

[56] References Cited

U.S. PATENT DOCUMENTS

D. 241,329 9/1976 Forster et al. .... D12/85

OTHER PUBLICATIONS

Domus, 10/74, p. 41, Three-Wheeled Vehicle.

Primary Examiner—James M. Gandy

Attorney, Agent, or Firm—Ostrolenk, Faber, Gerb & Soffen

[57] CLAIM

The ornamental design for a self-propelled three wheeled vehicle, as shown and described.

DESCRIPTION

FIG. 1 is a top, right, front perspective view of a self-propelled three wheeled vehicle, showing my new design, with the rear restraint bar in raised condition; FIG. 2 is a top, left, rear perspective view thereof with the rear restraint bar in lowered condition; FIG. 3 is a right side elevation view thereof; FIG. 4 is a top plan view thereof; FIG. 5 is a front elevation view thereof; FIG. 6 is a rear elevation view thereof; FIG. 7 is a top, left rear perspective view thereof with a wheel-chair shown loaded on said vehicle it being understood that the wheel-chair is shown in broken lines for illustrative purposes only and forms no part of the claimed design; FIG. 8 is a top, right, front perspective view of a self-propelled three wheeled vehicle showing a second embodiment of my new design, the sole difference being in the addition of a chair; FIG. 9 is a right side elevation view of FIG. 8; FIG. 10 is a top plan view of FIG. 8; FIG. 11 is a front elevation view of FIG. 8; and FIG. 12 is a rear elevation view of FIG. 8.

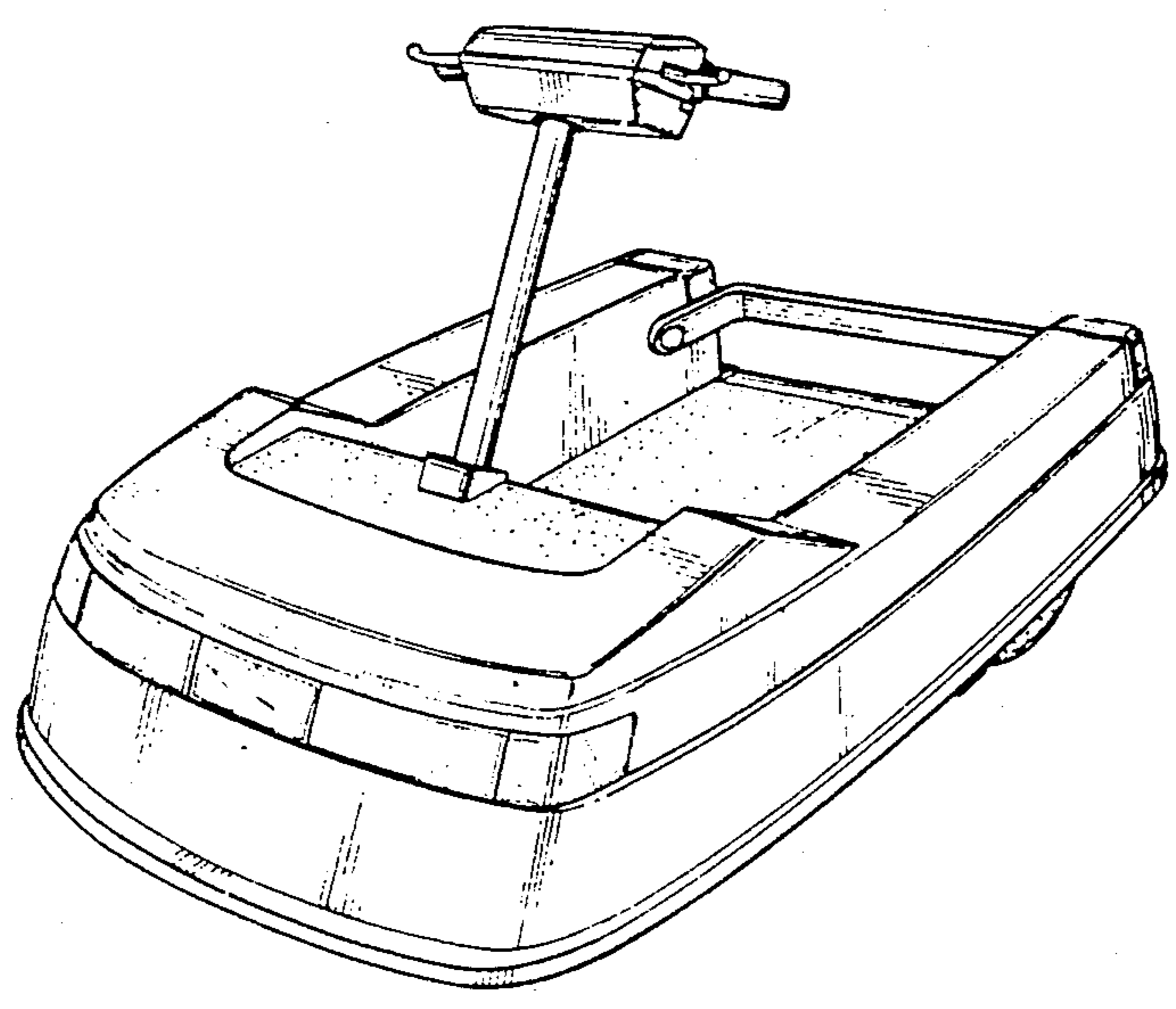

FIG. 1

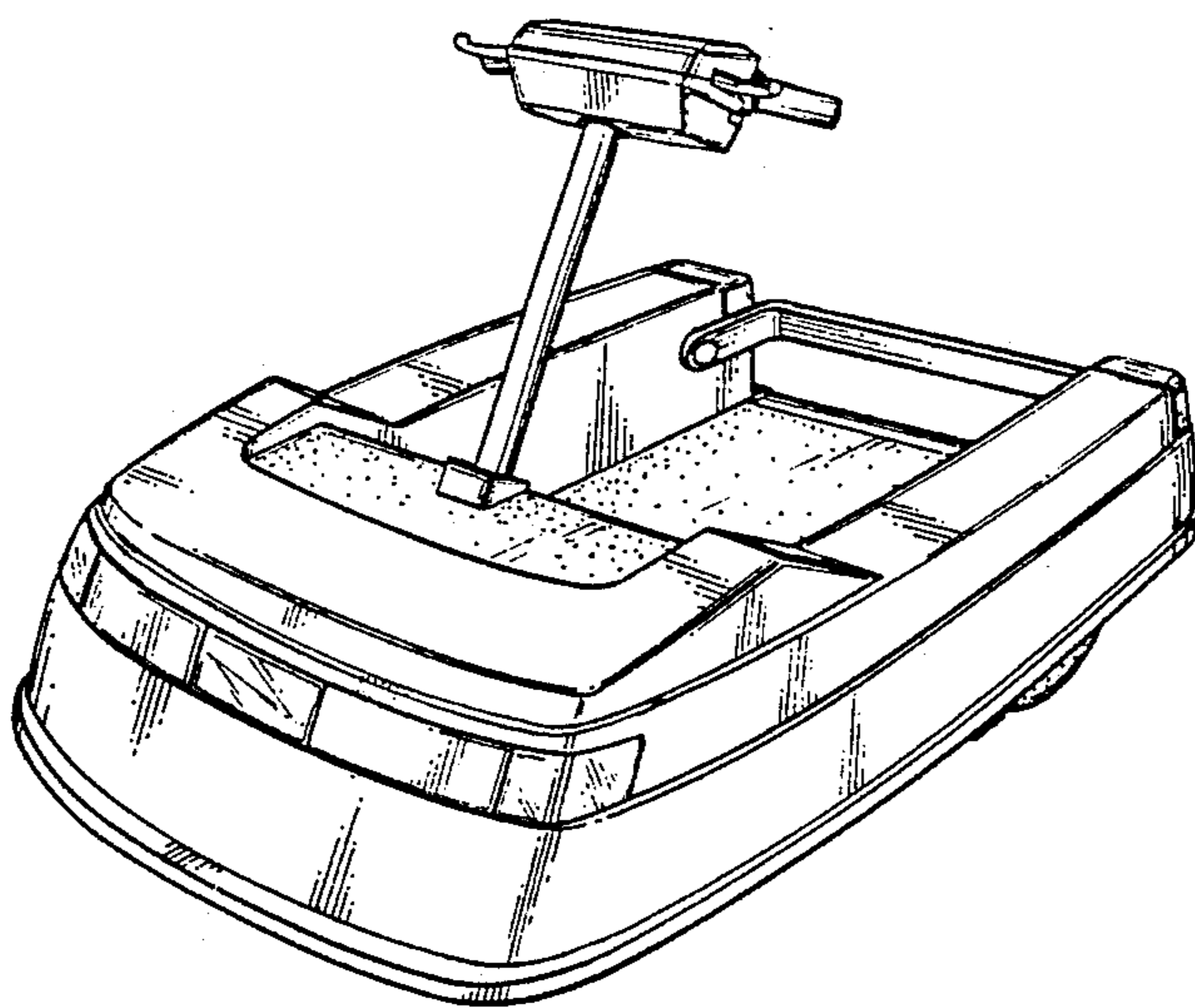

FIG. 2

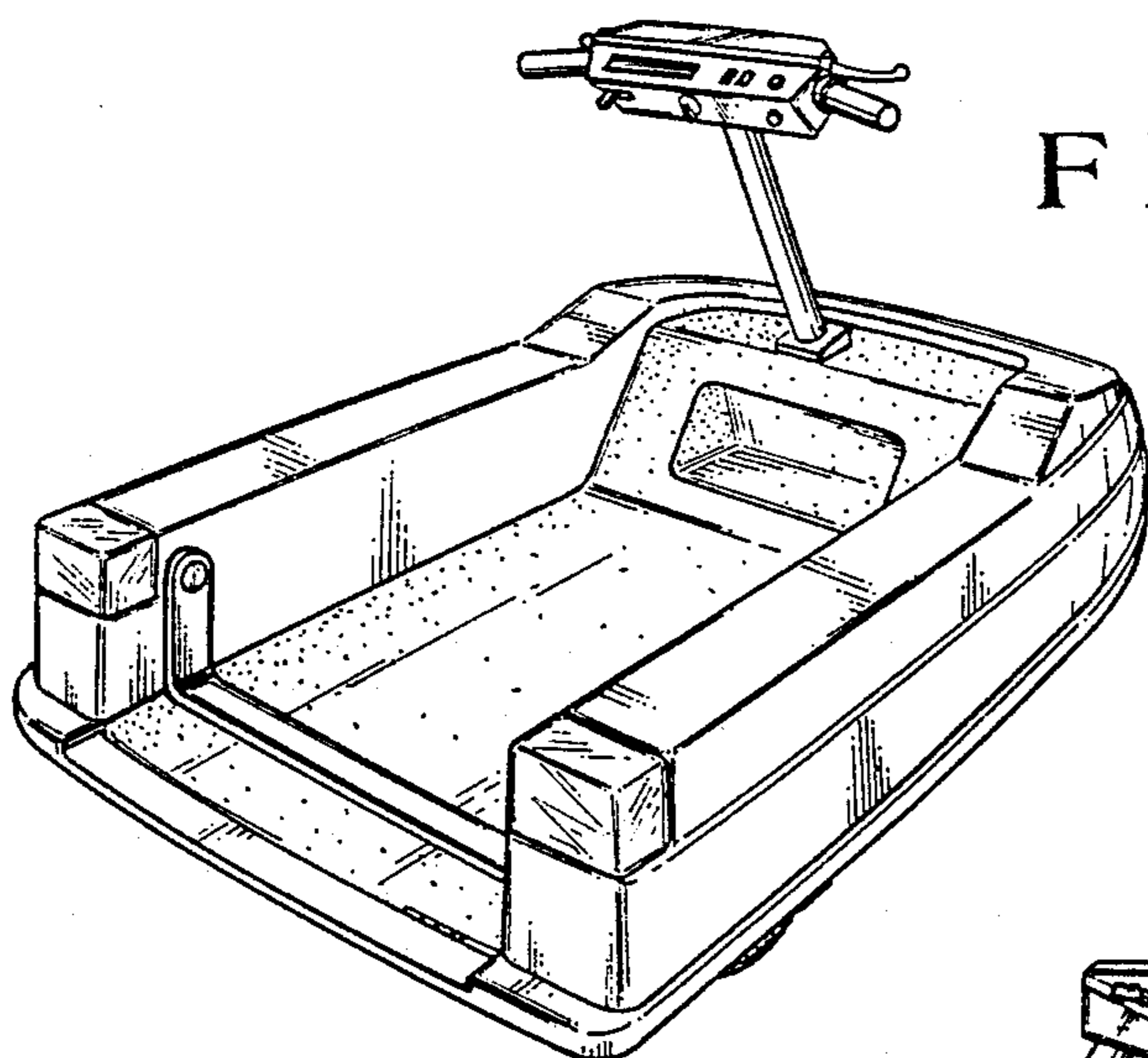

FIG. 3

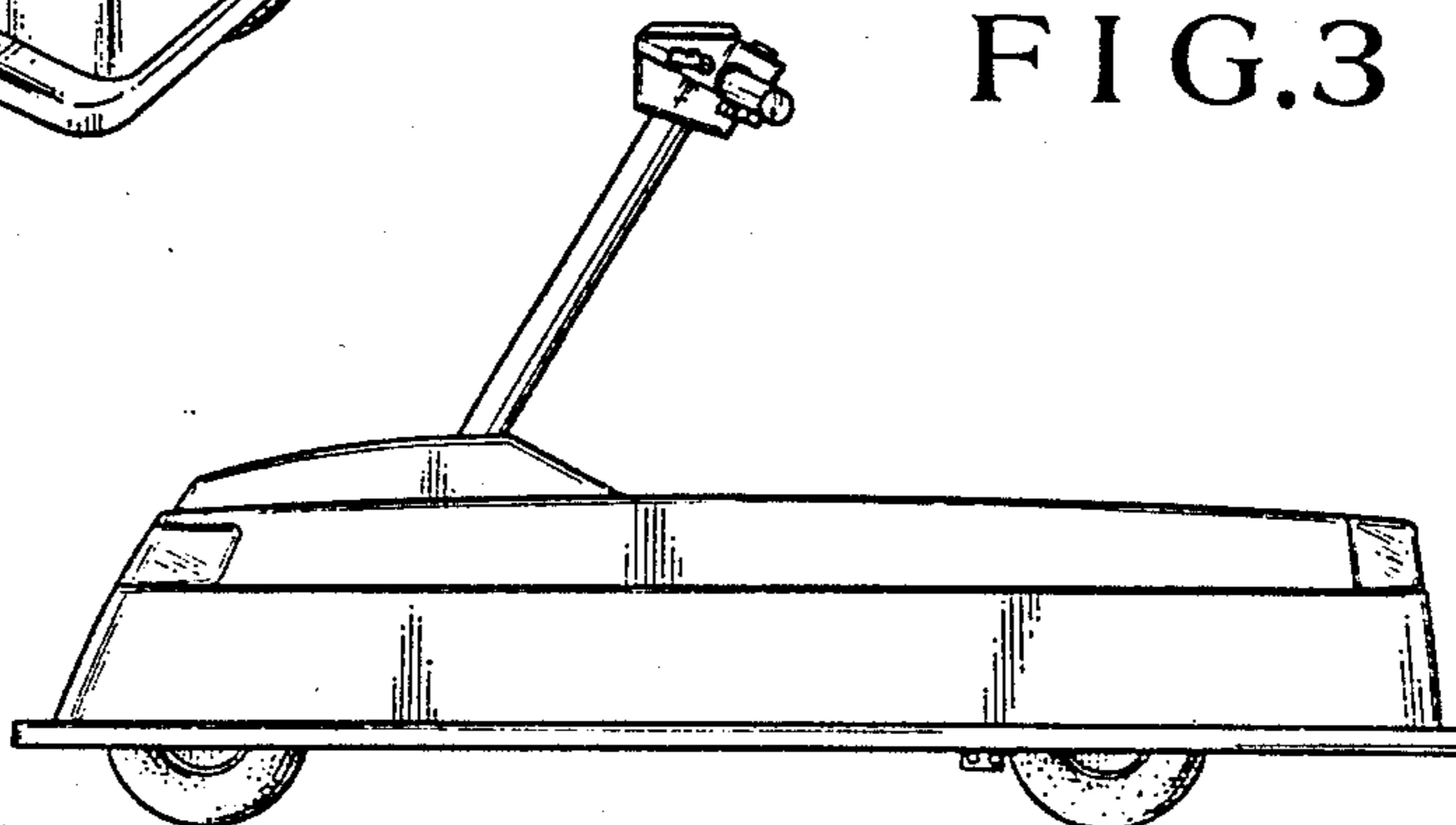

FIG. 4

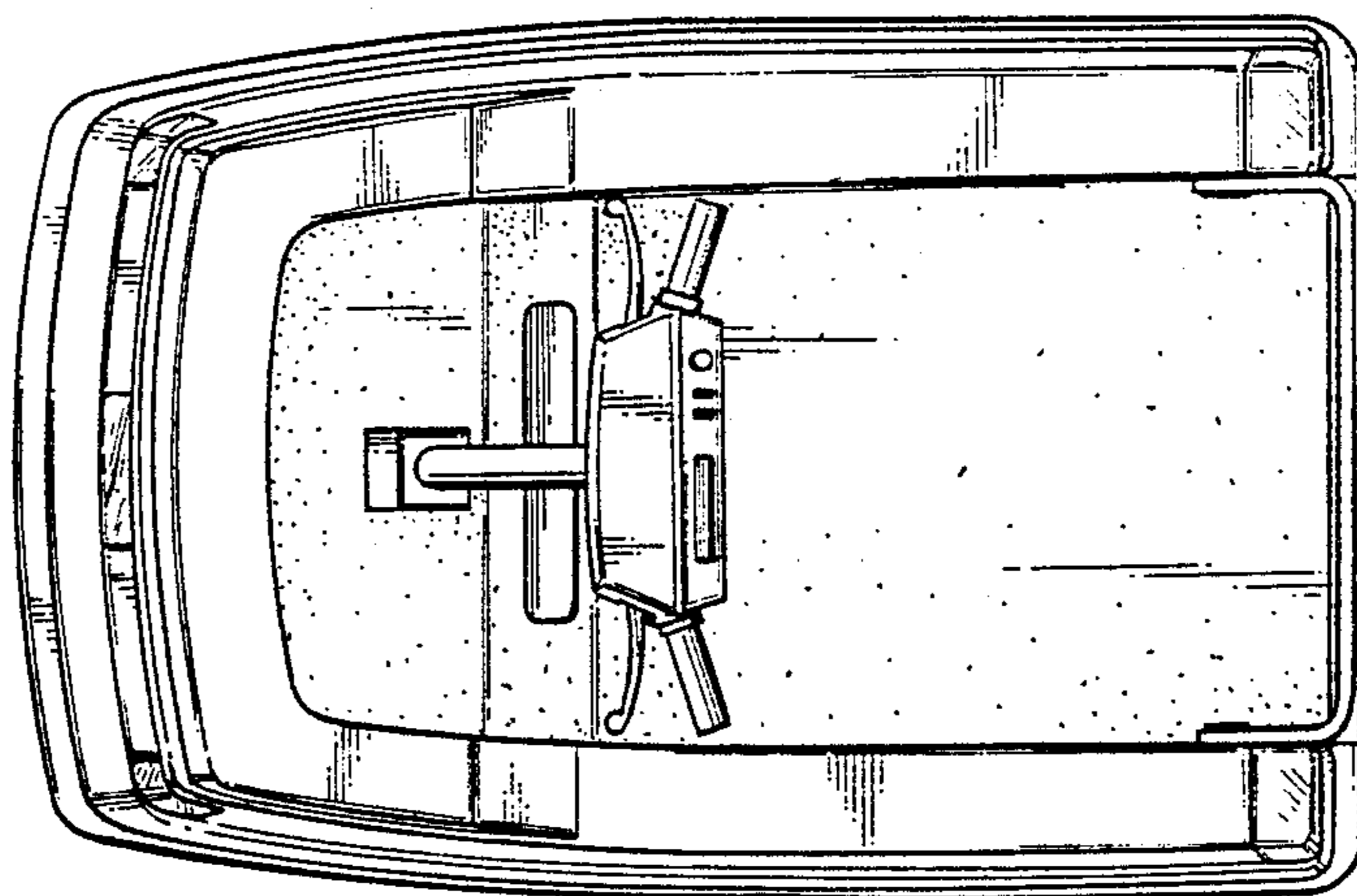

FIG. 5

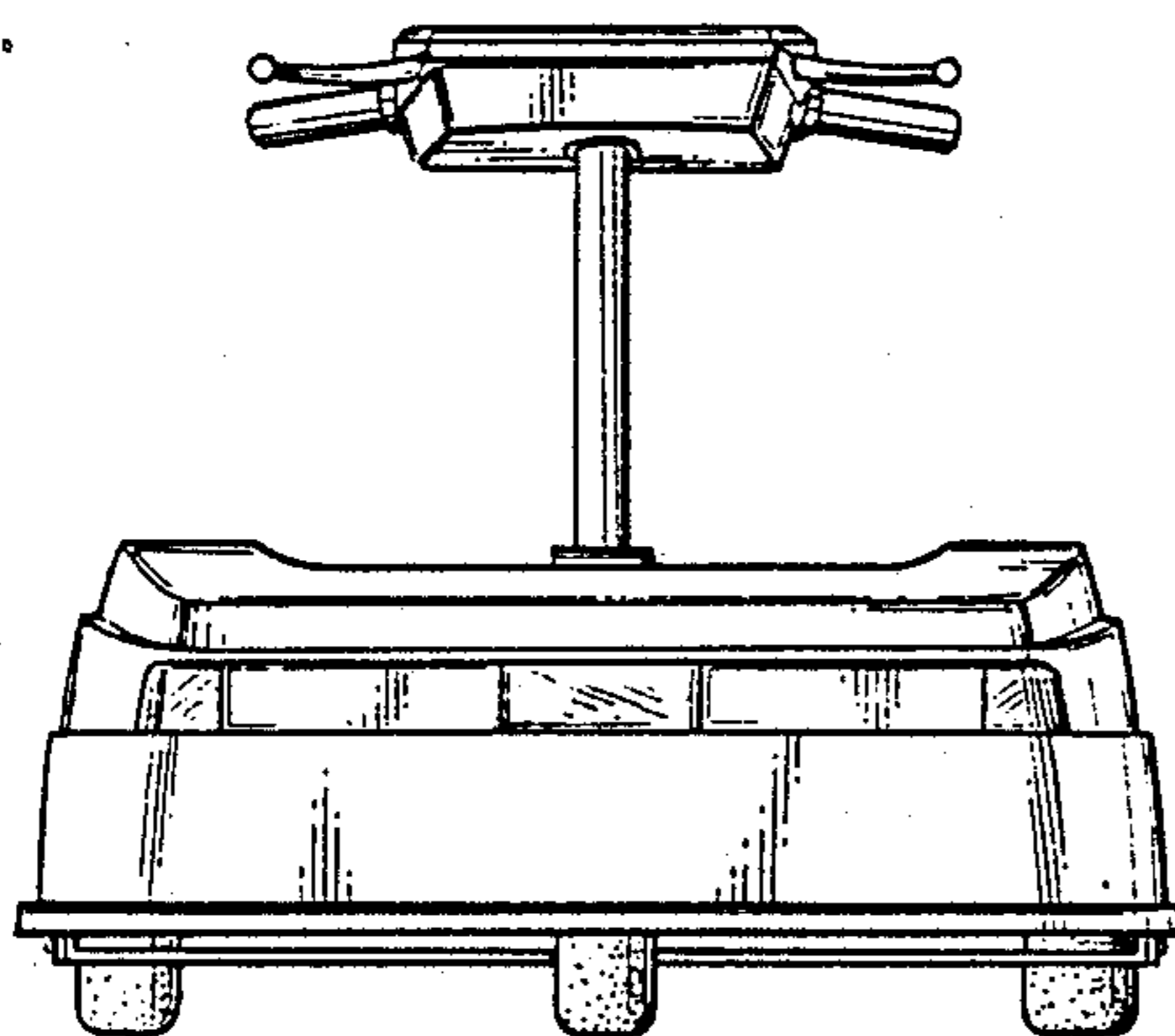

FIG. 6

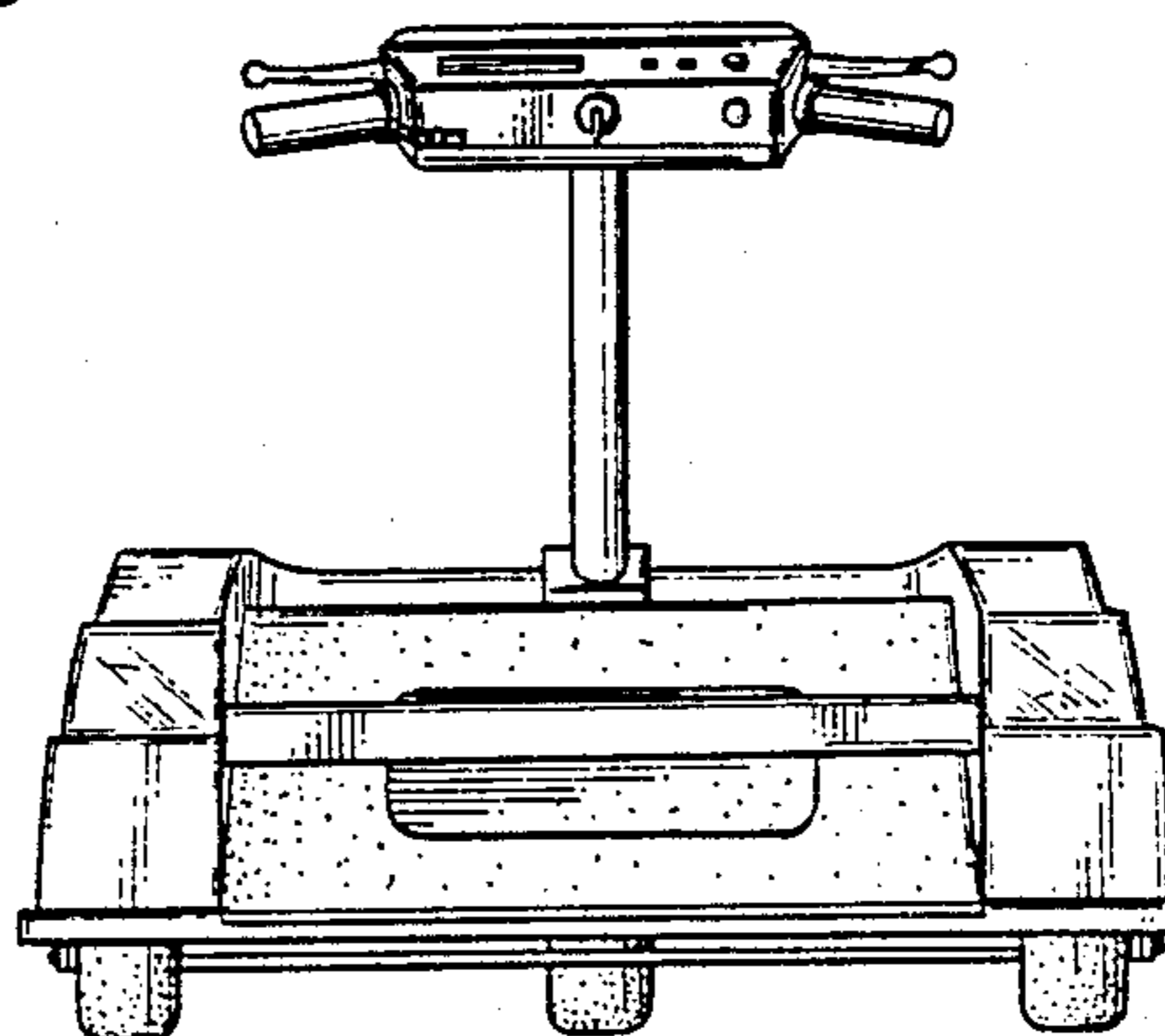

FIG. 7

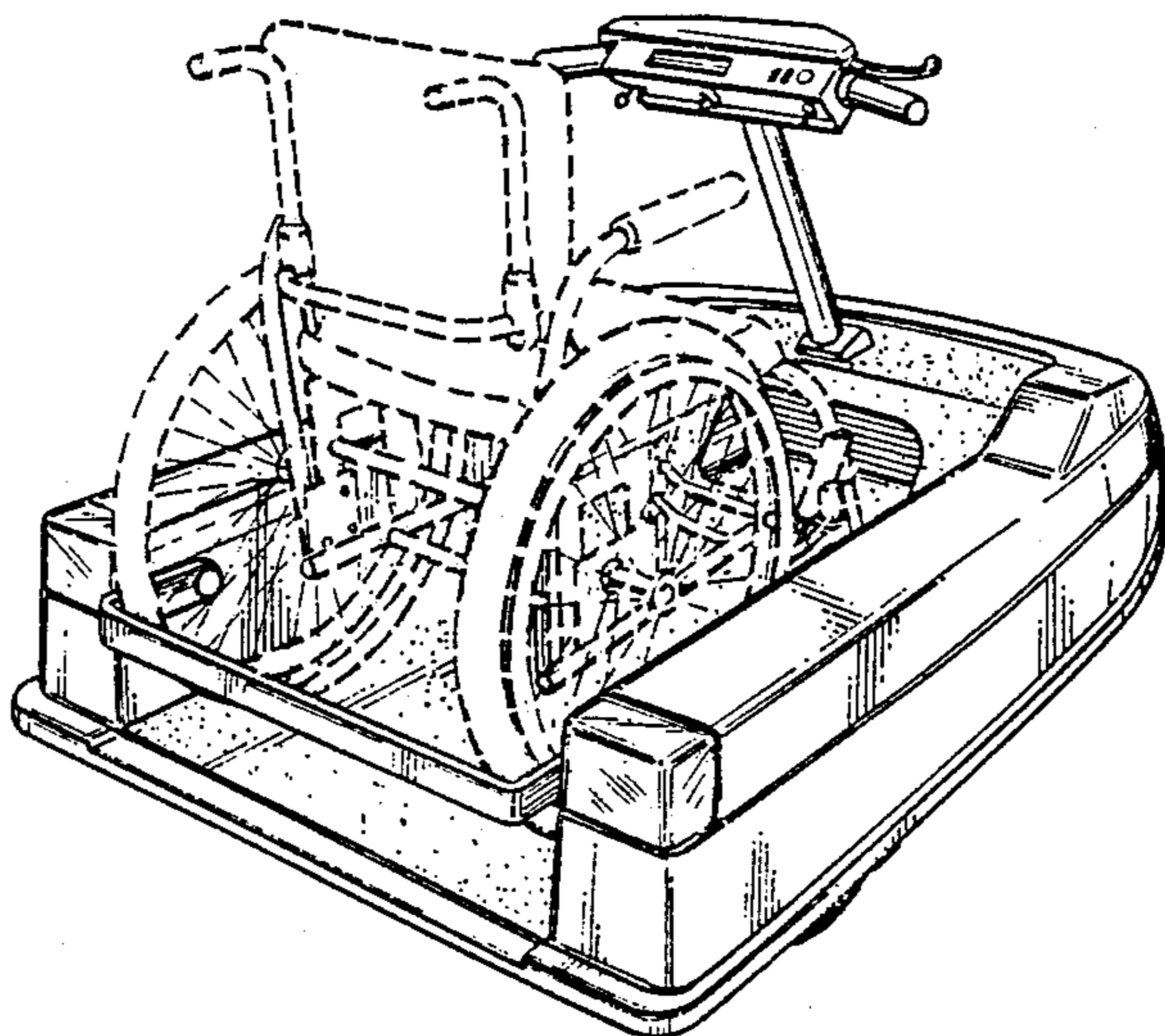

FIG. 8

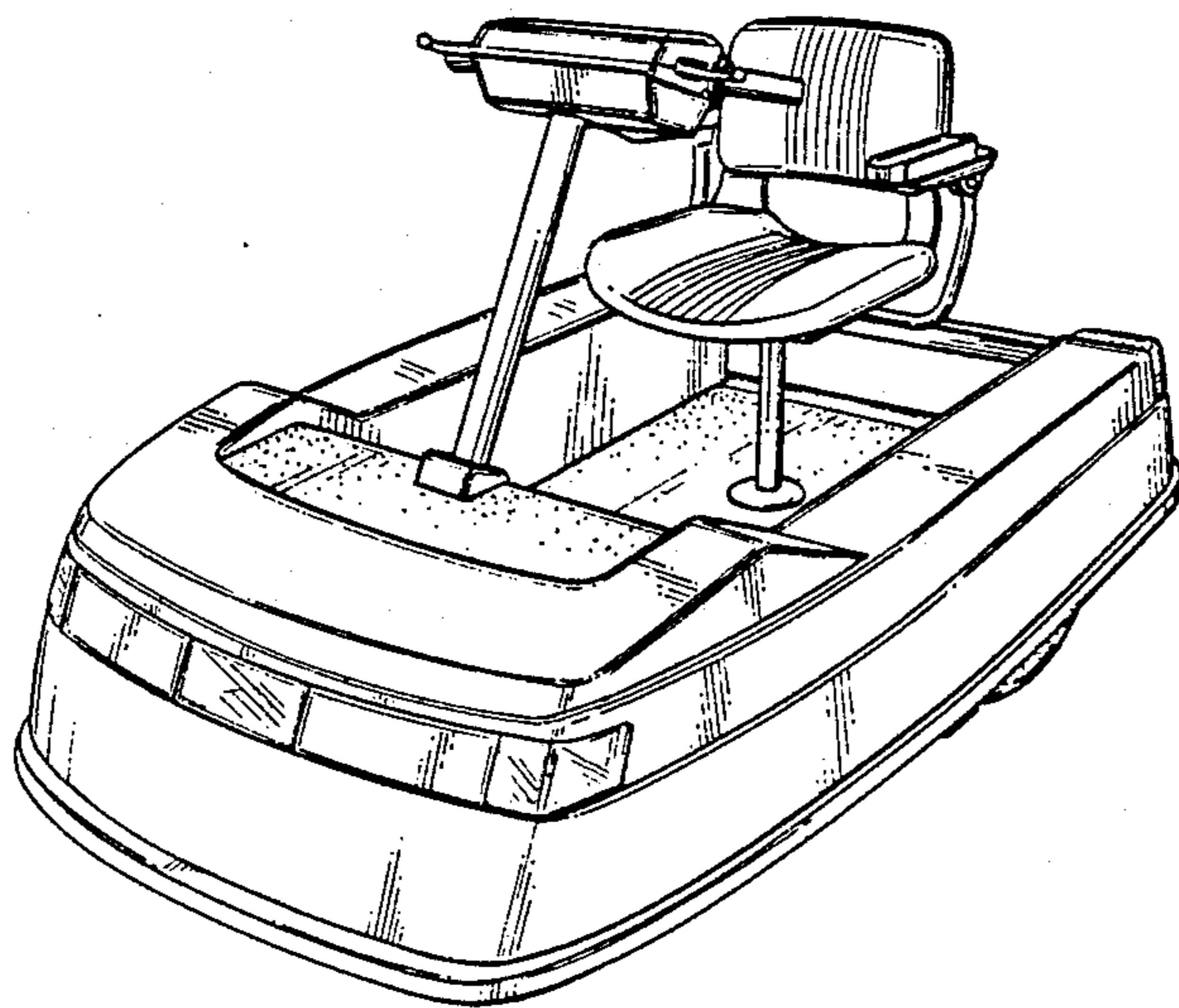

FIG. 9

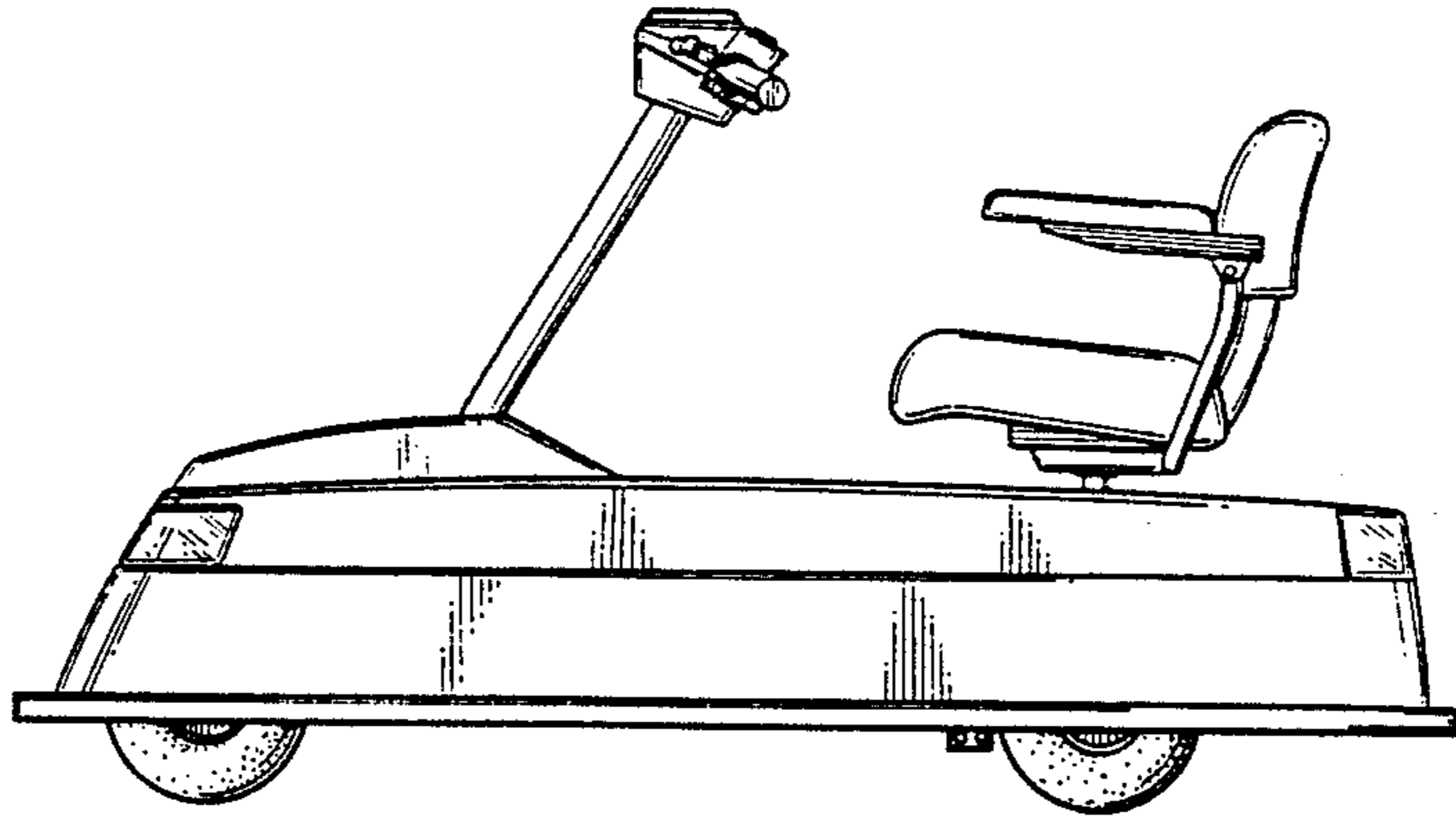

FIG. 10

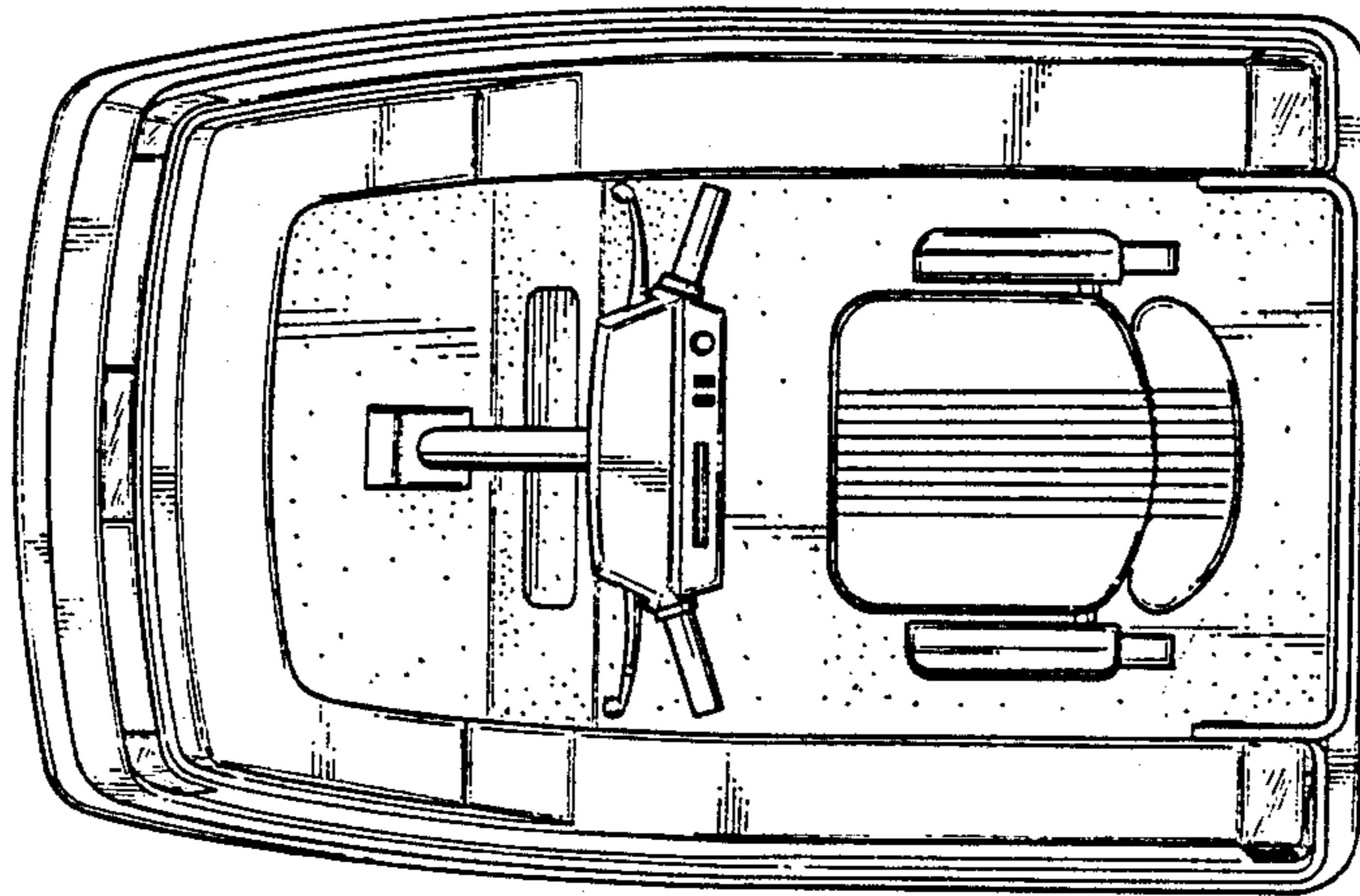

FIG. 11

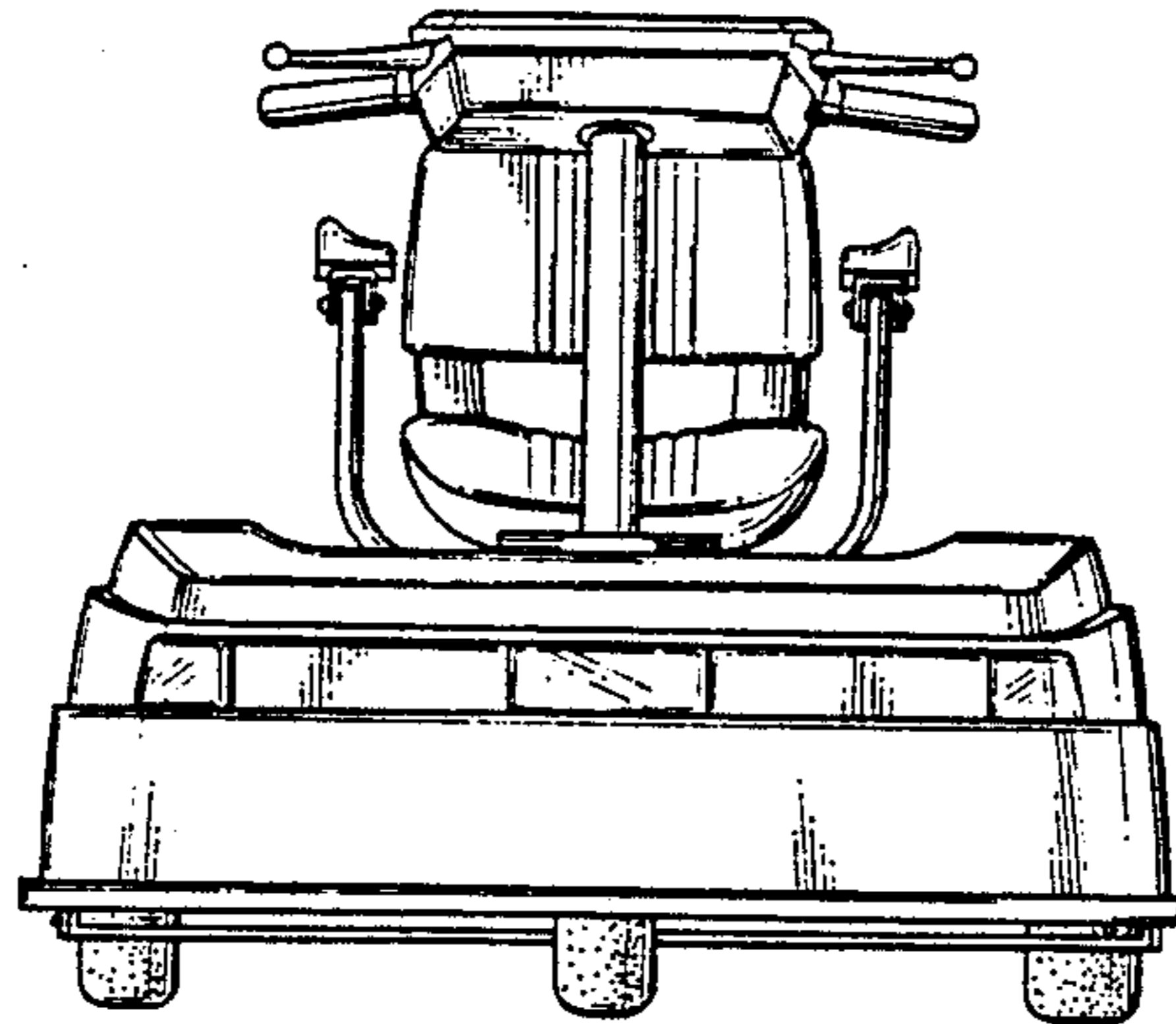

FIG. 12

