

[54] CUTTING TOOL INSERT

[75] Inventor: Kenneth L. Niebauer, Raleigh, N.C.

[73] Assignee: Kennametal Inc., Latrobe, Pa.

[**] Term: 14 Years

[21] Appl. No.: 147,007

[22] Filed: Jan. 22, 1988

[52] U.S. Cl. D15/139; 407/114

[58] Field of Search 407/113, 114, 115, 116, 407/117, 42; D15/138, 139, 140

[56] References Cited

U.S. PATENT DOCUMENTS

D. 275,396	9/1984	Porat et al. .	
D. 280,514	9/1985	Porat et al.	D15/139
D. 291,889	9/1987	Petterson et al. .	
3,636,602	1/1972	Owen	407/113
3,733,664	5/1973	McKeluey .	
3,792,514	2/1974	Ushijima	407/115 X
3,968,550	7/1976	Gehri	407/114
4,318,644	3/1982	Seidel	D15/139 X
4,318,645	3/1982	McCreery .	
4,340,324	7/1982	McCreery .	
4,359,300	11/1982	Hazra et al.	407/114
4,411,565	10/1983	Hazra et al.	407/114
4,507,024	3/1985	Stashko	407/114
4,685,844	8/1987	McCreery et al. .	
4,741,649	5/1988	Mori	407/114
4,787,784	11/1988	Bernadic et al.	407/114

OTHER PUBLICATIONS

"Sandvik Coromant's New Turning Generation," an advertisement, dated 1987.

"Chip Control Inserts," an advertisement of Kennametal Inc., published Feb. 1987.

Primary Examiner—James R. Lergen
Assistant Examiner—Jeffrey Asch
Attorney, Agent, or Firm—Thomas R. Trempus

[57] CLAIM

The ornamental design for a cutting tool insert, as shown and described.

DESCRIPTION

FIG. 1 is a top and left side perspective view of a cutting tool insert showing my new design;
 FIG. 2 is a top plan view;
 FIG. 3 is an elevational view, taken from the right side;
 FIG. 4 is a bottom plan view;
 FIG. 5 is a cross sectional view taken along line V—V in FIG. 2;
 FIG. 6 is a top and left side perspective view showing a second embodiment of that shown in FIGS. 1-5;
 FIG. 7 is a top plan view;
 FIG. 8 is an elevational view taken from the right side;
 FIG. 9 is a bottom plan view;
 FIG. 10 is a cross sectional view taken along line X—X in FIG. 7;
 FIG. 11 is a top and left side perspective view showing a third embodiment of that shown in FIGS. 1-5;
 FIG. 12 is a top plan view;
 FIG. 13 is an elevational view taken from the right side;
 FIG. 14 is a bottom plan view;
 FIG. 15 is a cross sectional view taken along line XV—XV in FIG. 12;
 FIG. 16 is a top and left side perspective view showing a fourth embodiment of that shown in FIGS. 1-5;
 FIG. 17 is a top plan view;
 FIG. 18 is an elevational view taken from the right side;
 FIG. 19 is a bottom plan view; and,
 FIG. 20 is a cross sectional view taken along the line XX—XX in FIG. 17 thereof.

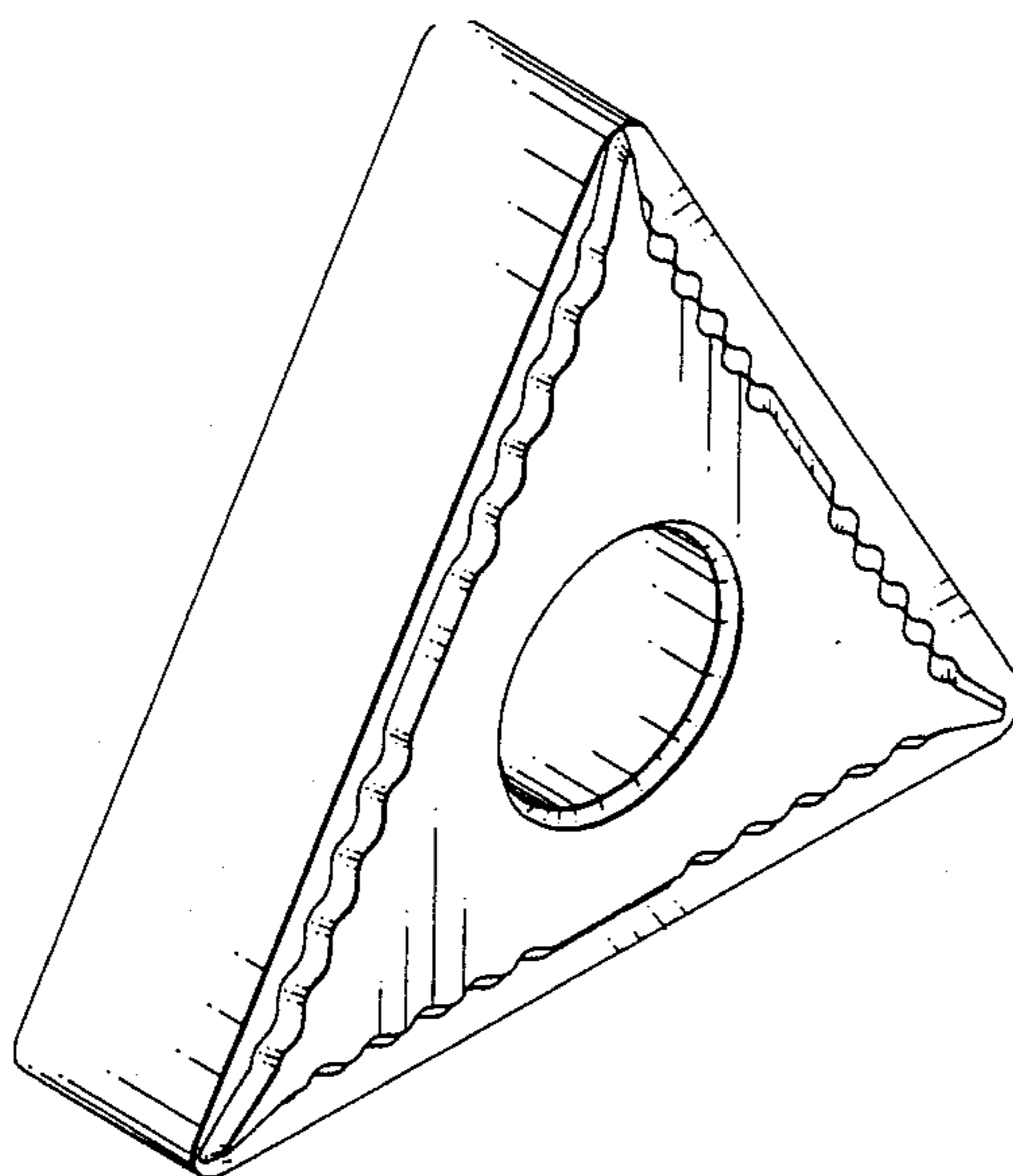

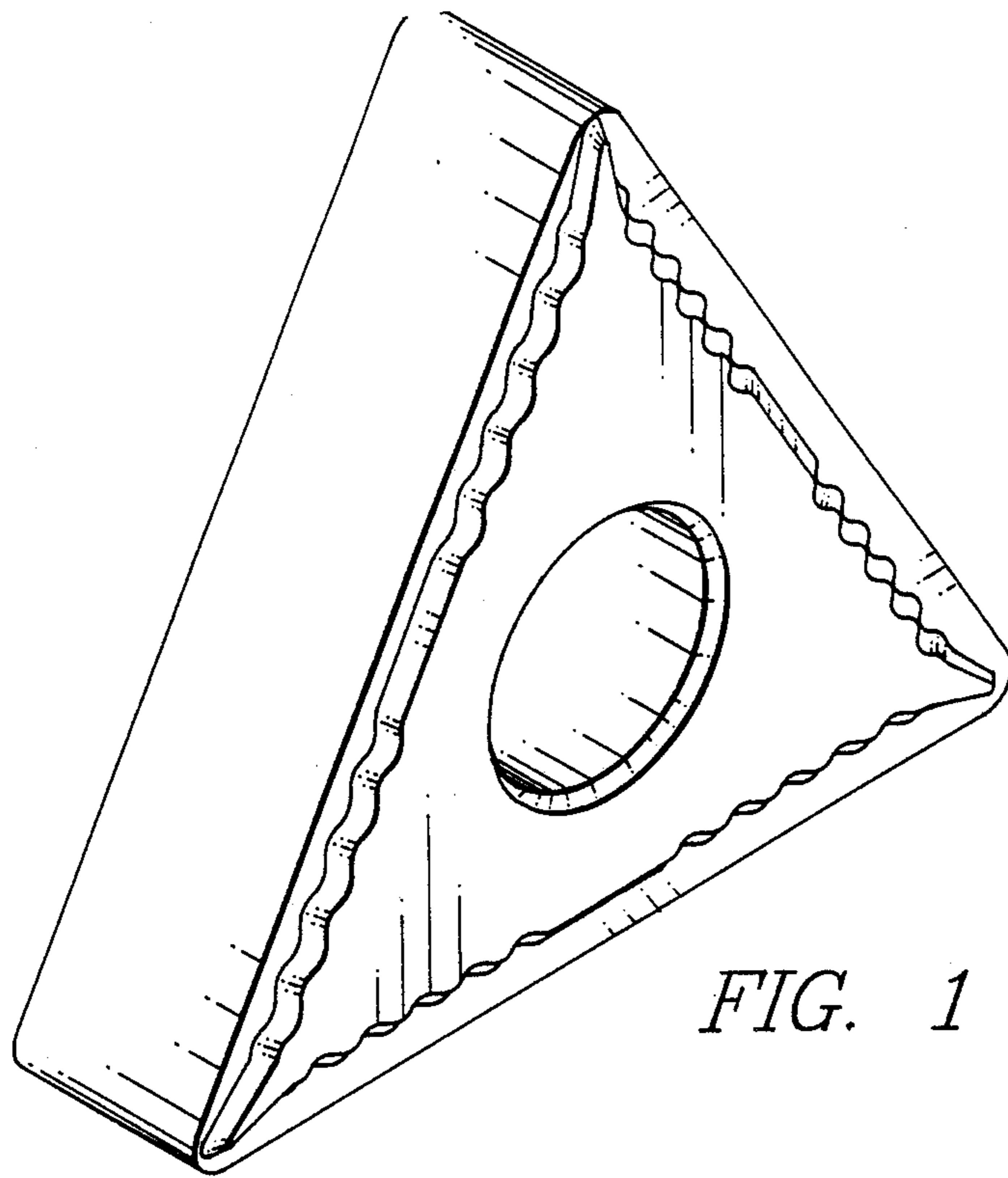

FIG. 1

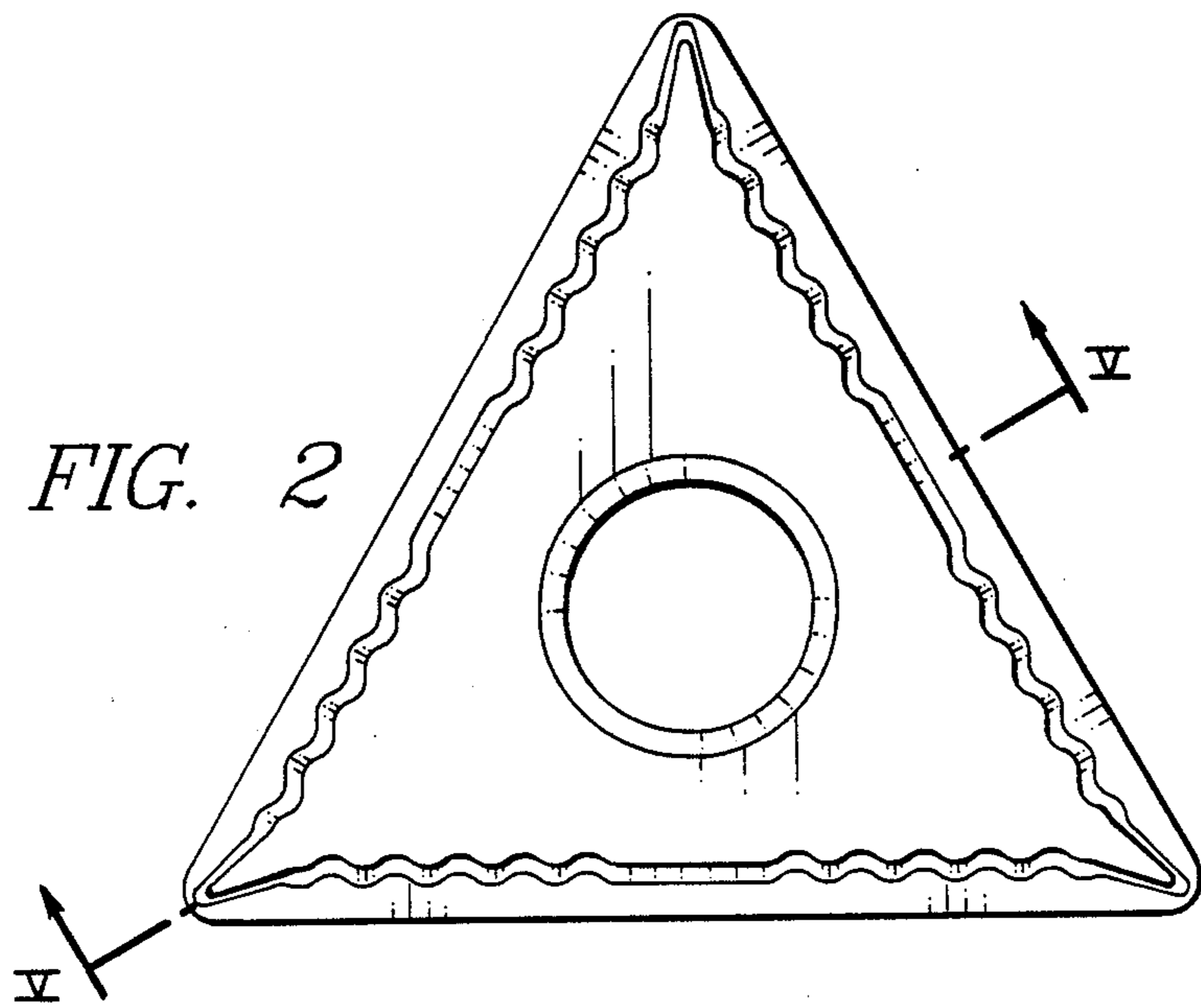

FIG. 2



FIG. 3

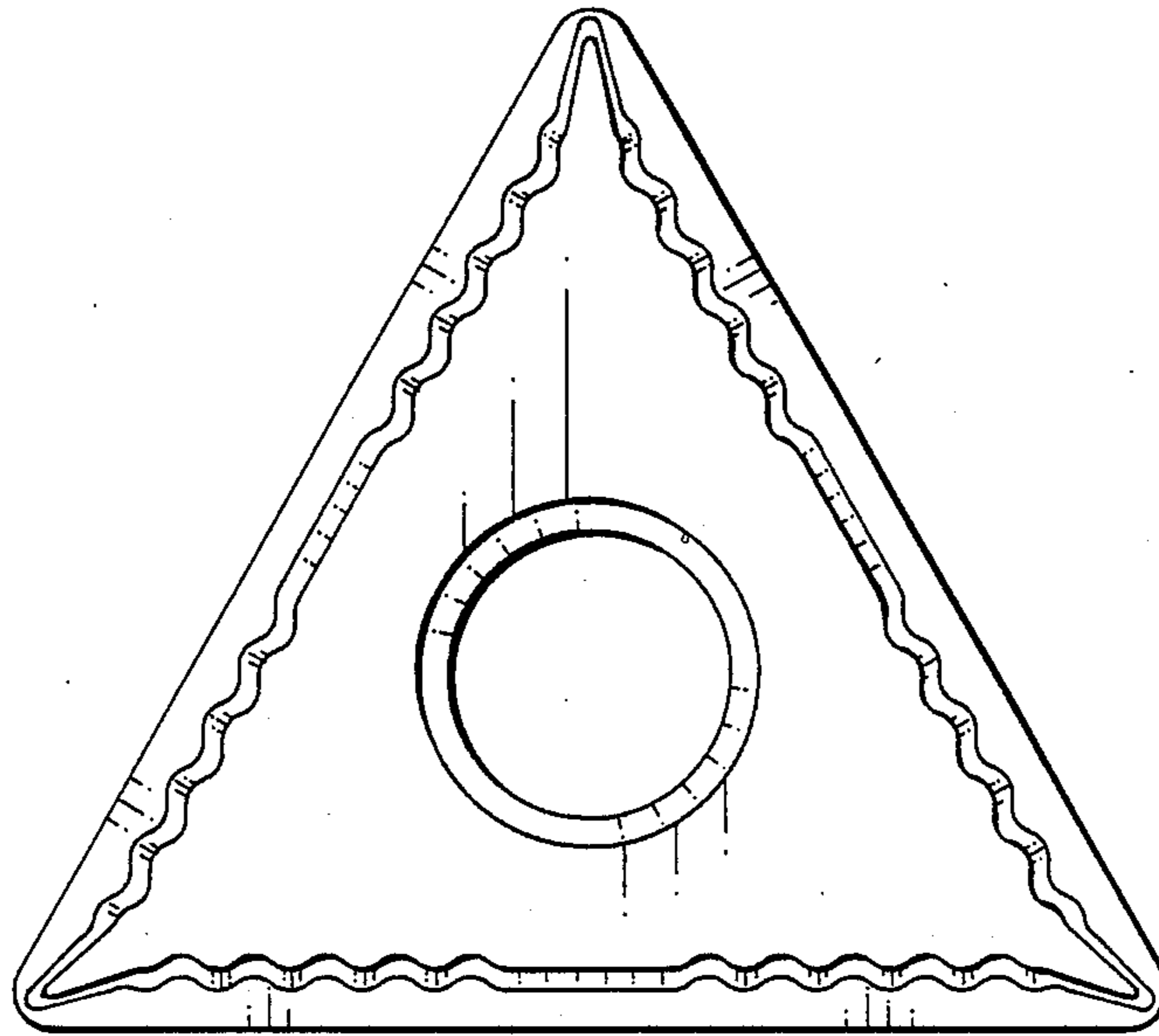

FIG. 4

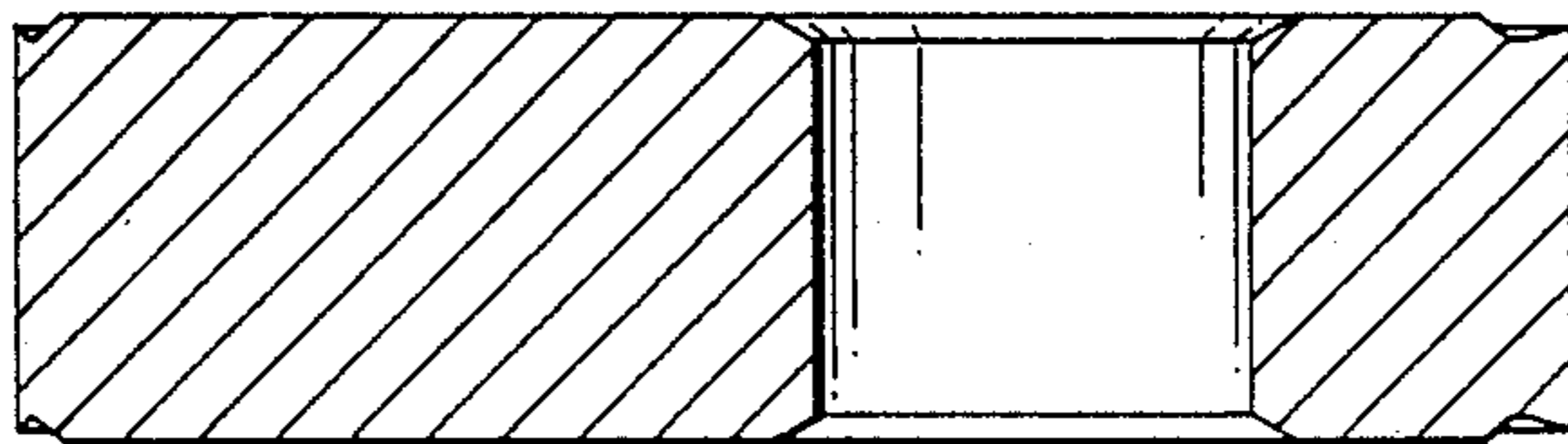

FIG. 5

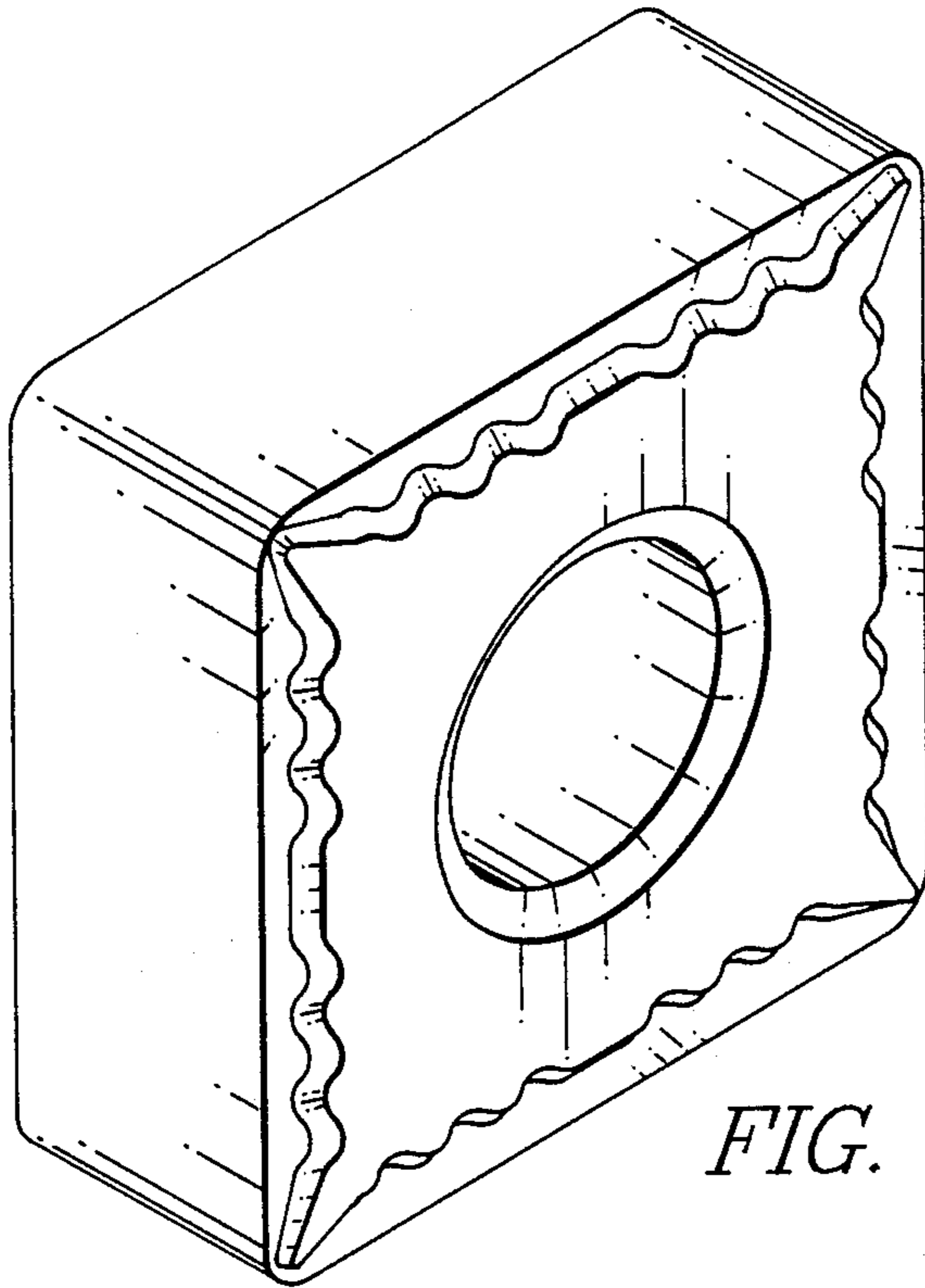

FIG. 6

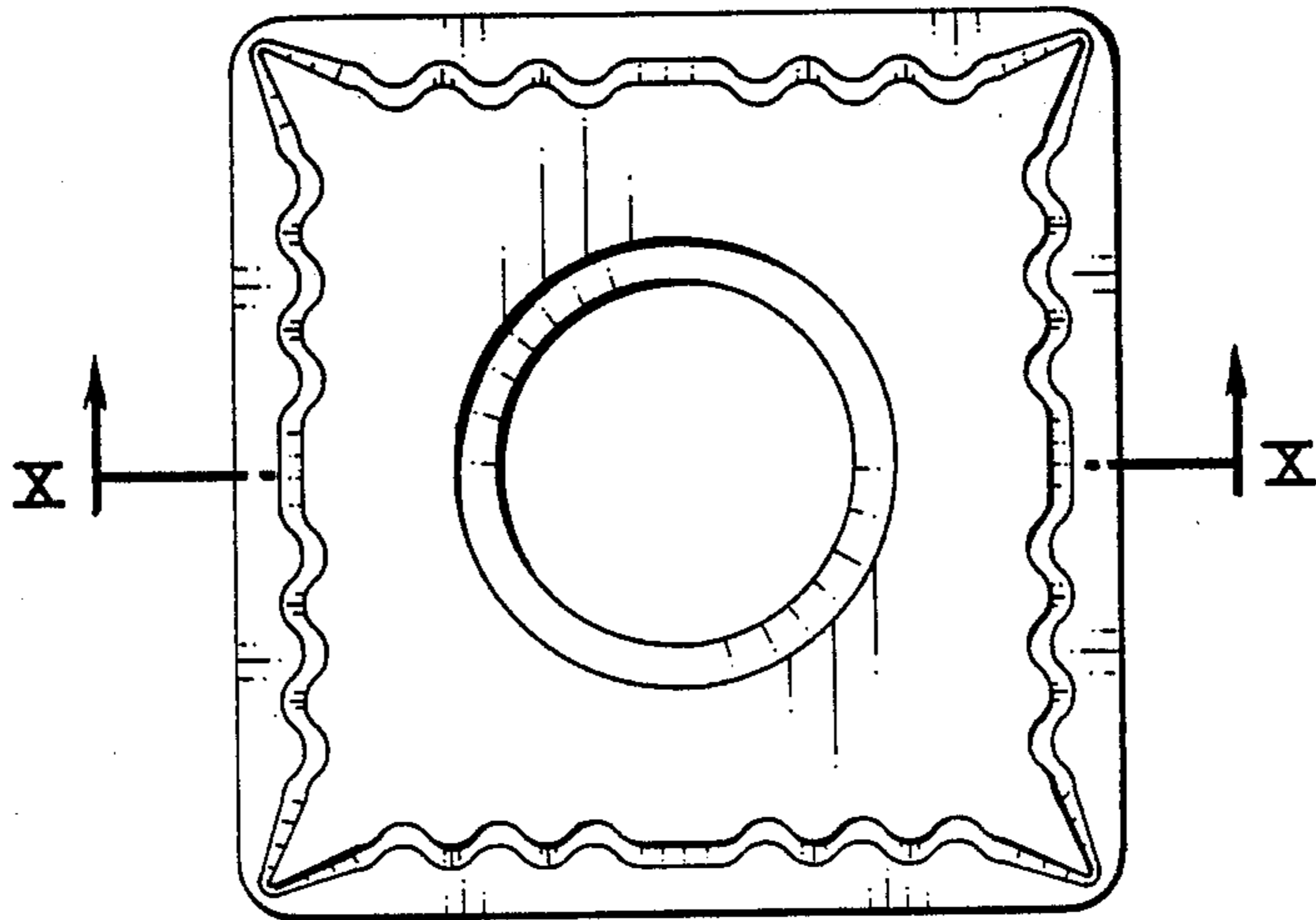

FIG. 7



FIG. 8

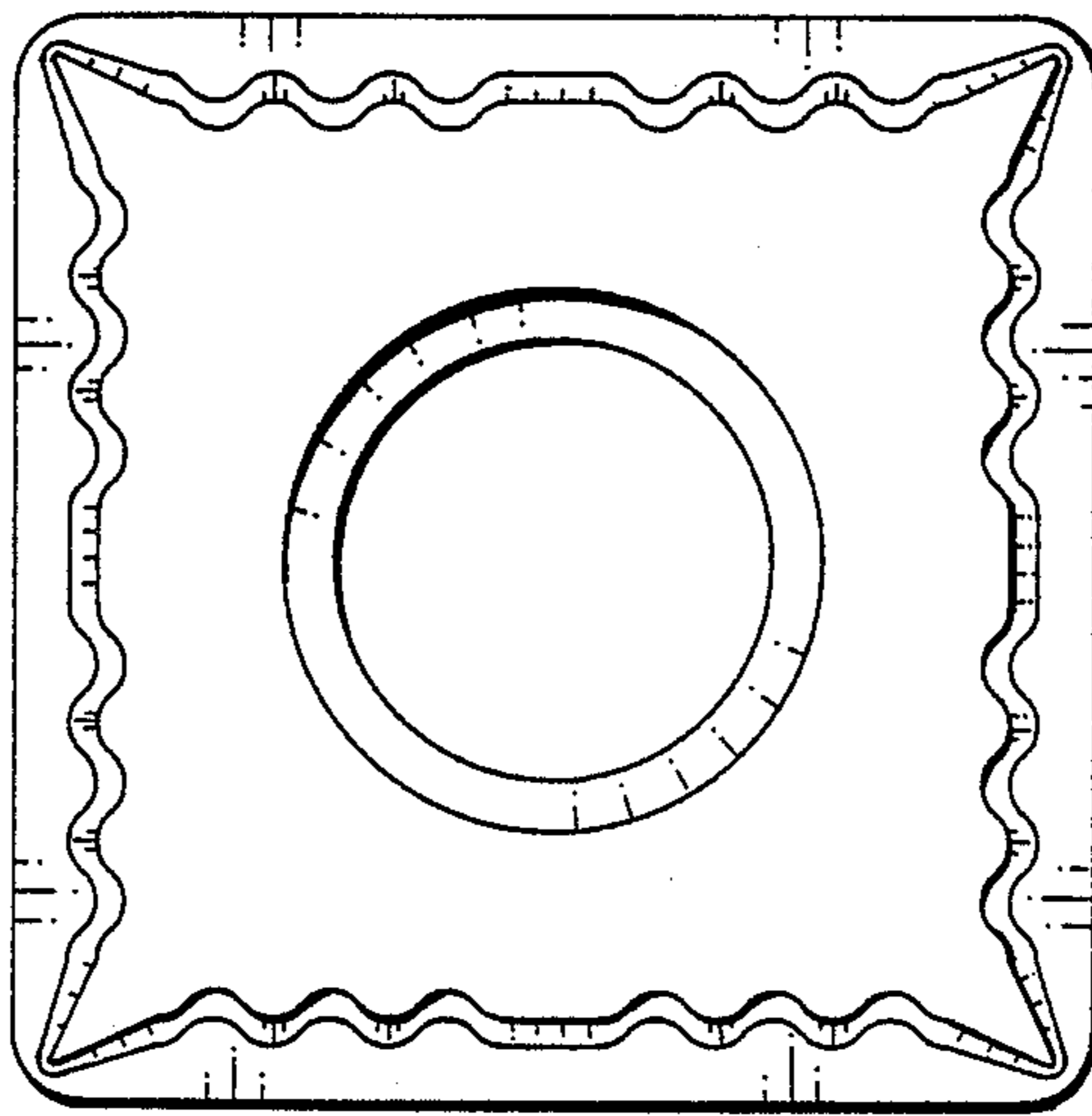

FIG. 9

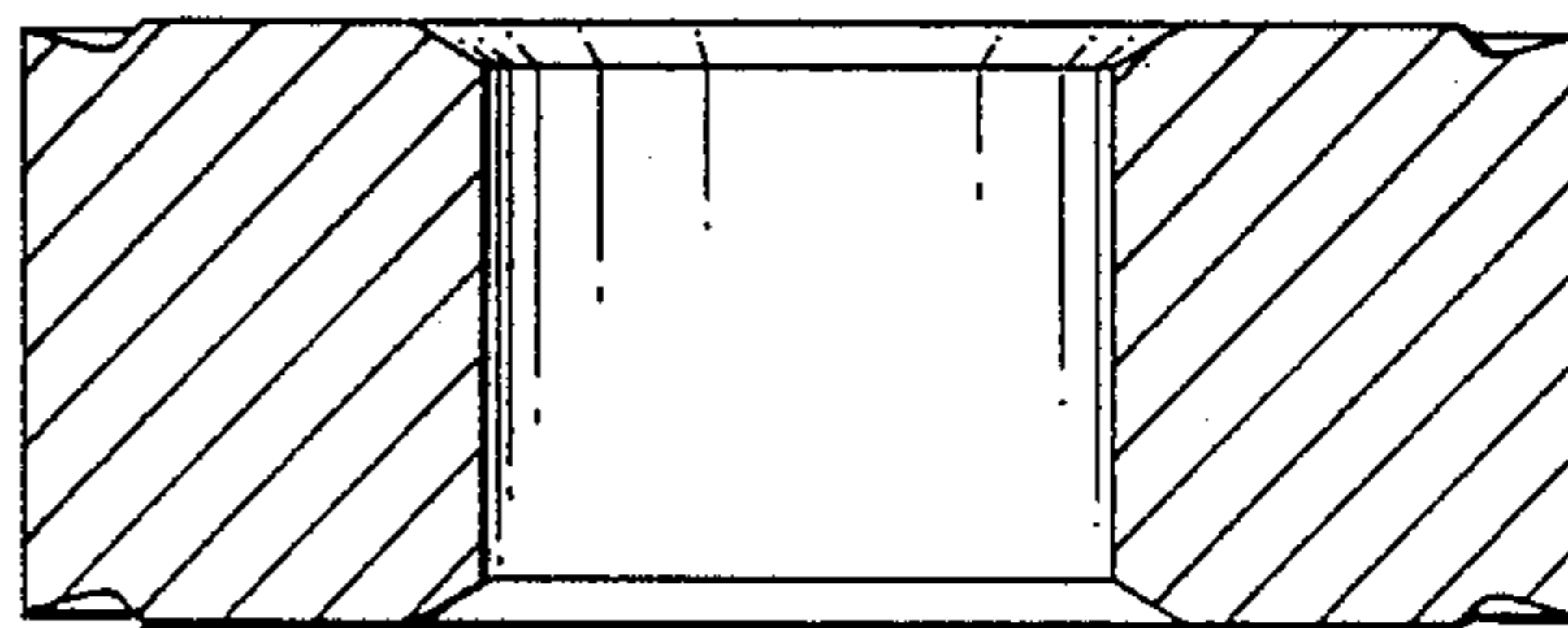

FIG. 10

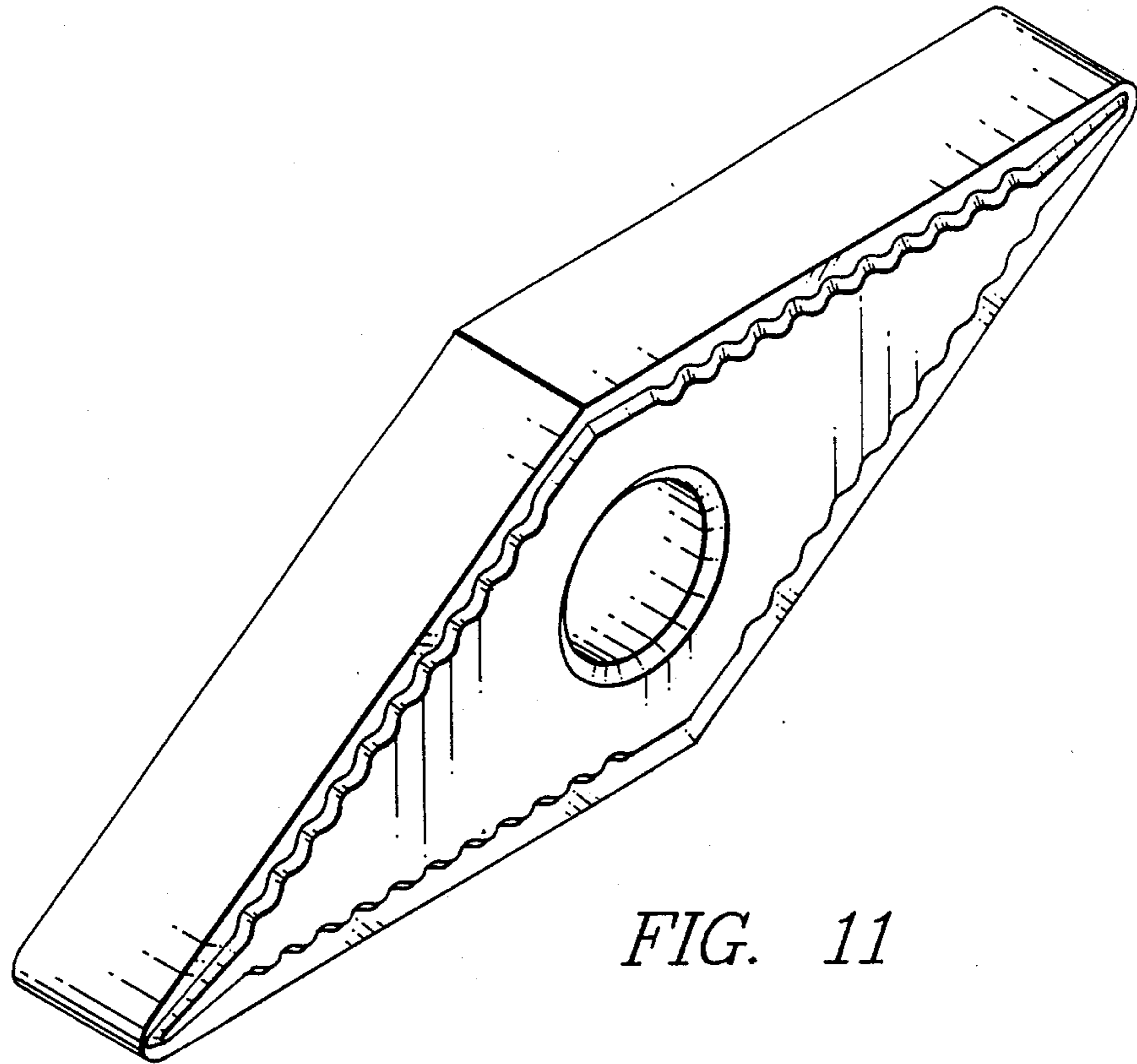

FIG. 11

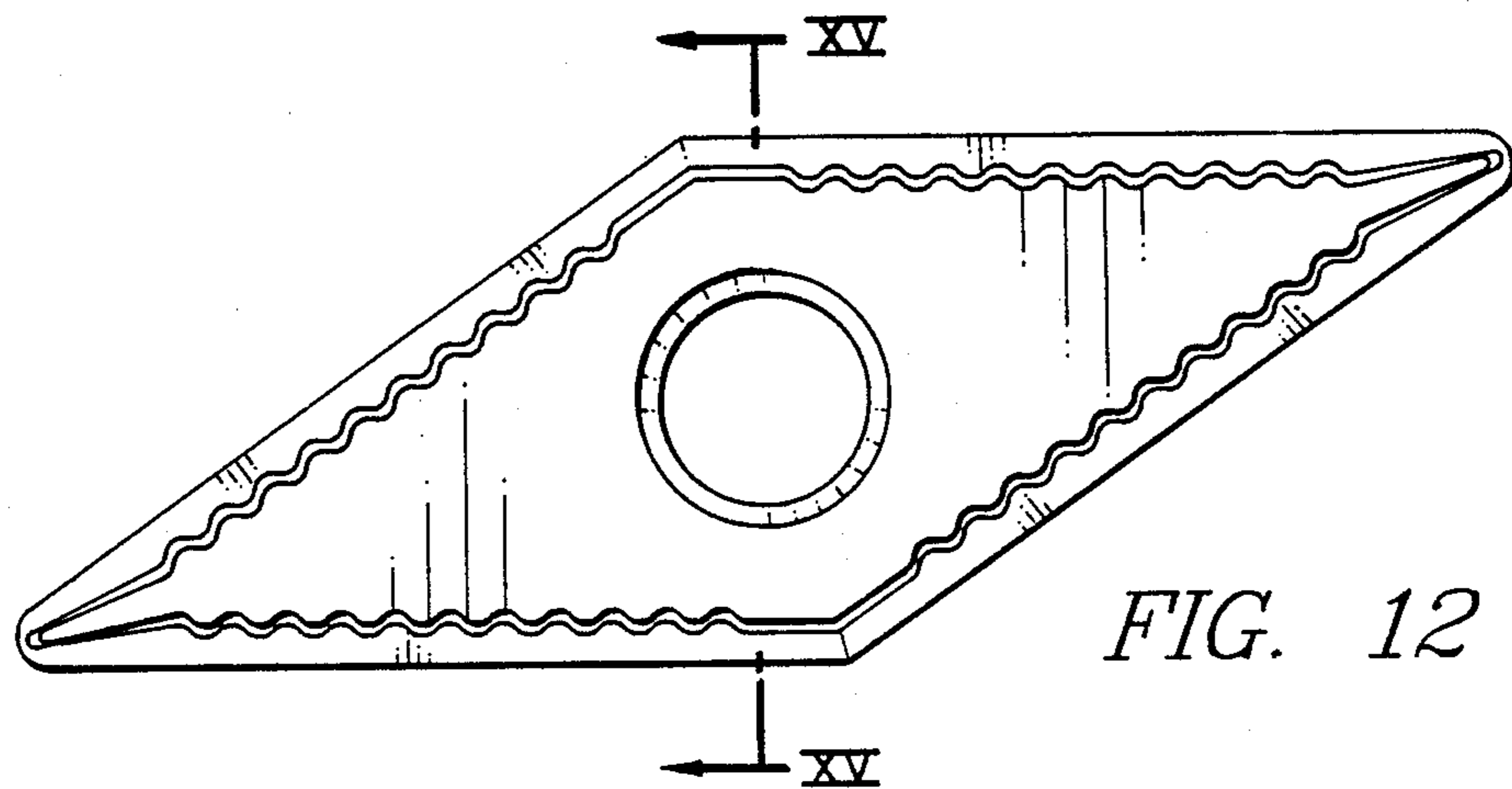

FIG. 12



FIG. 13

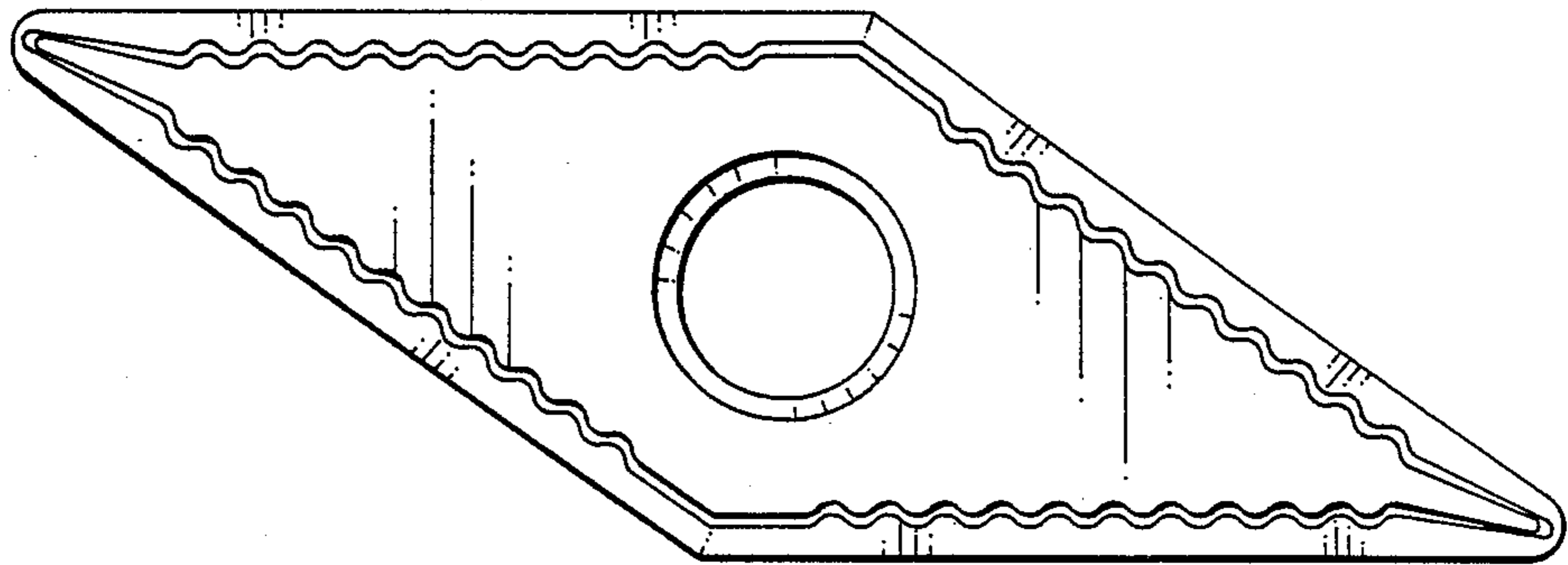

FIG. 14

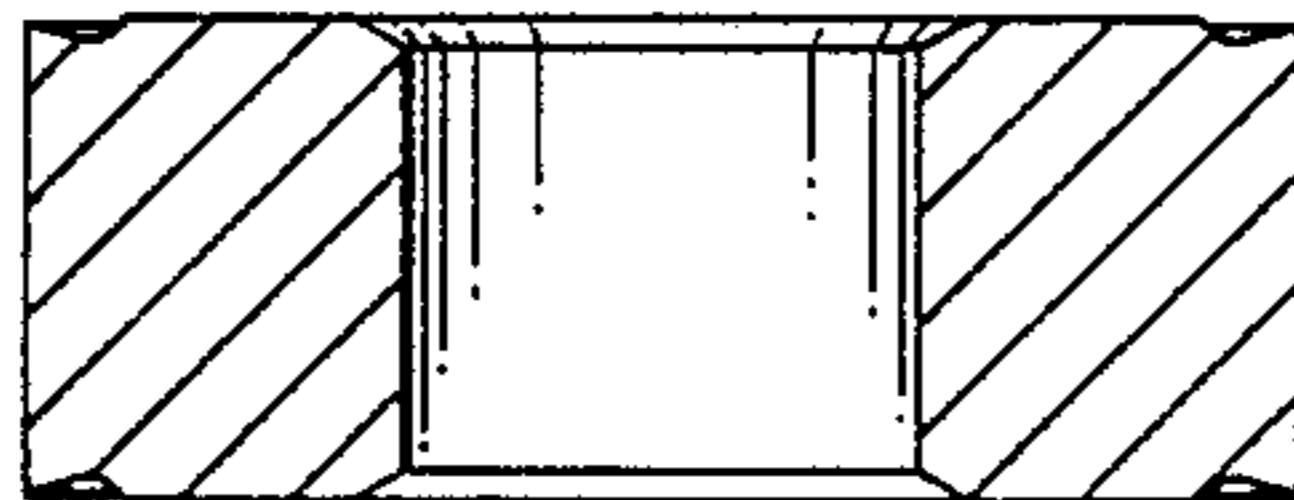

FIG. 15

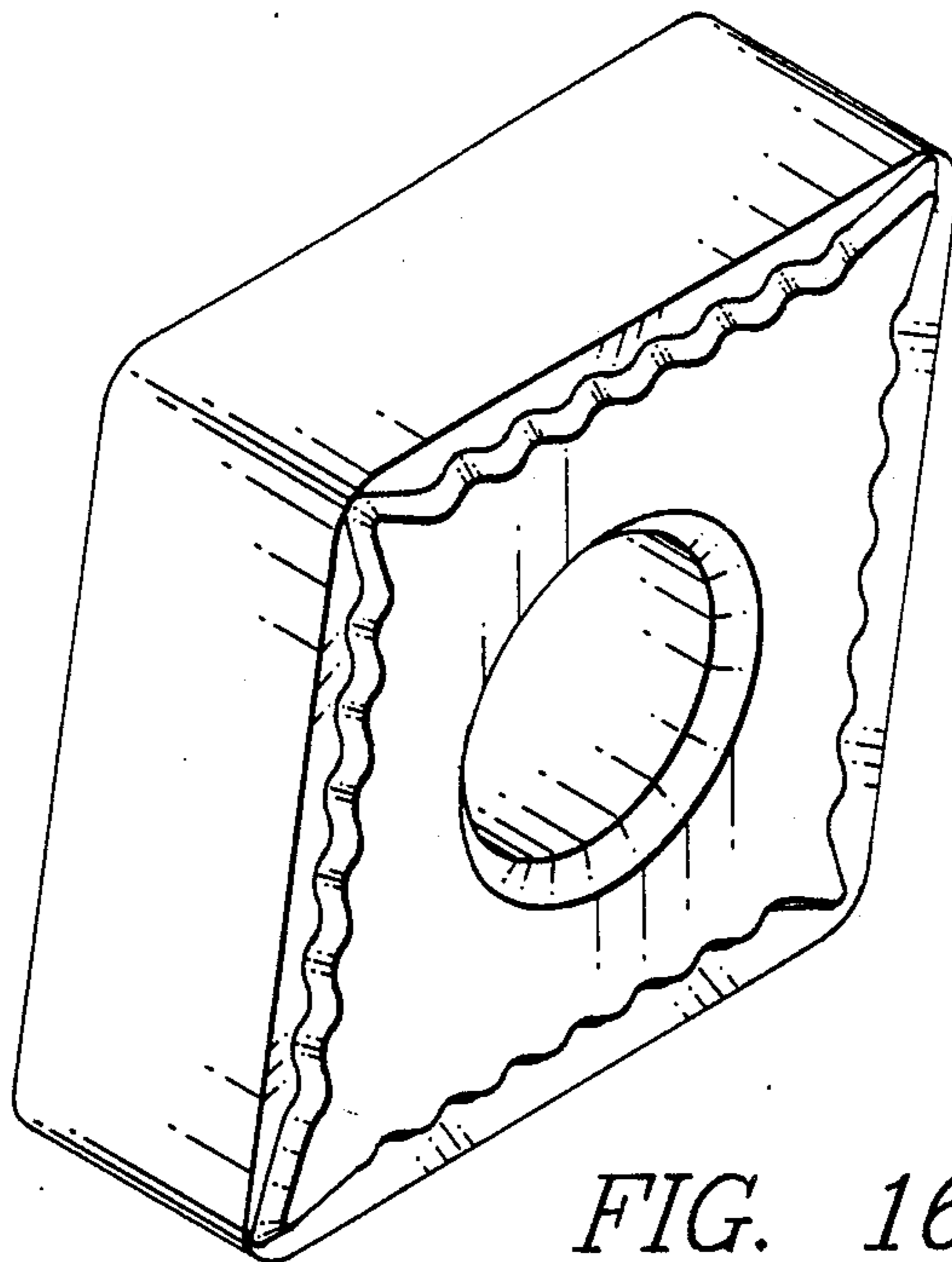

FIG. 16

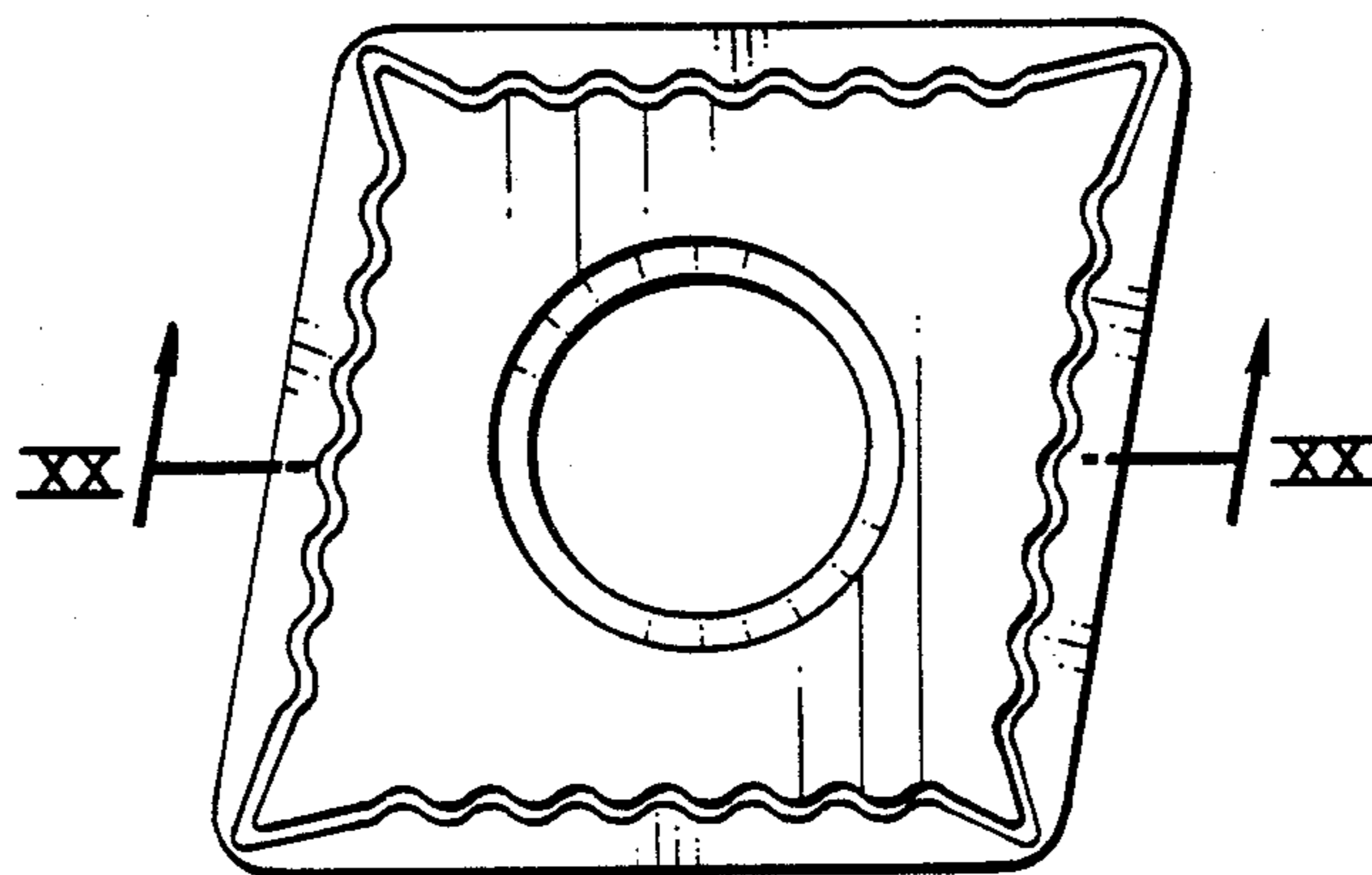

FIG. 17



FIG. 18

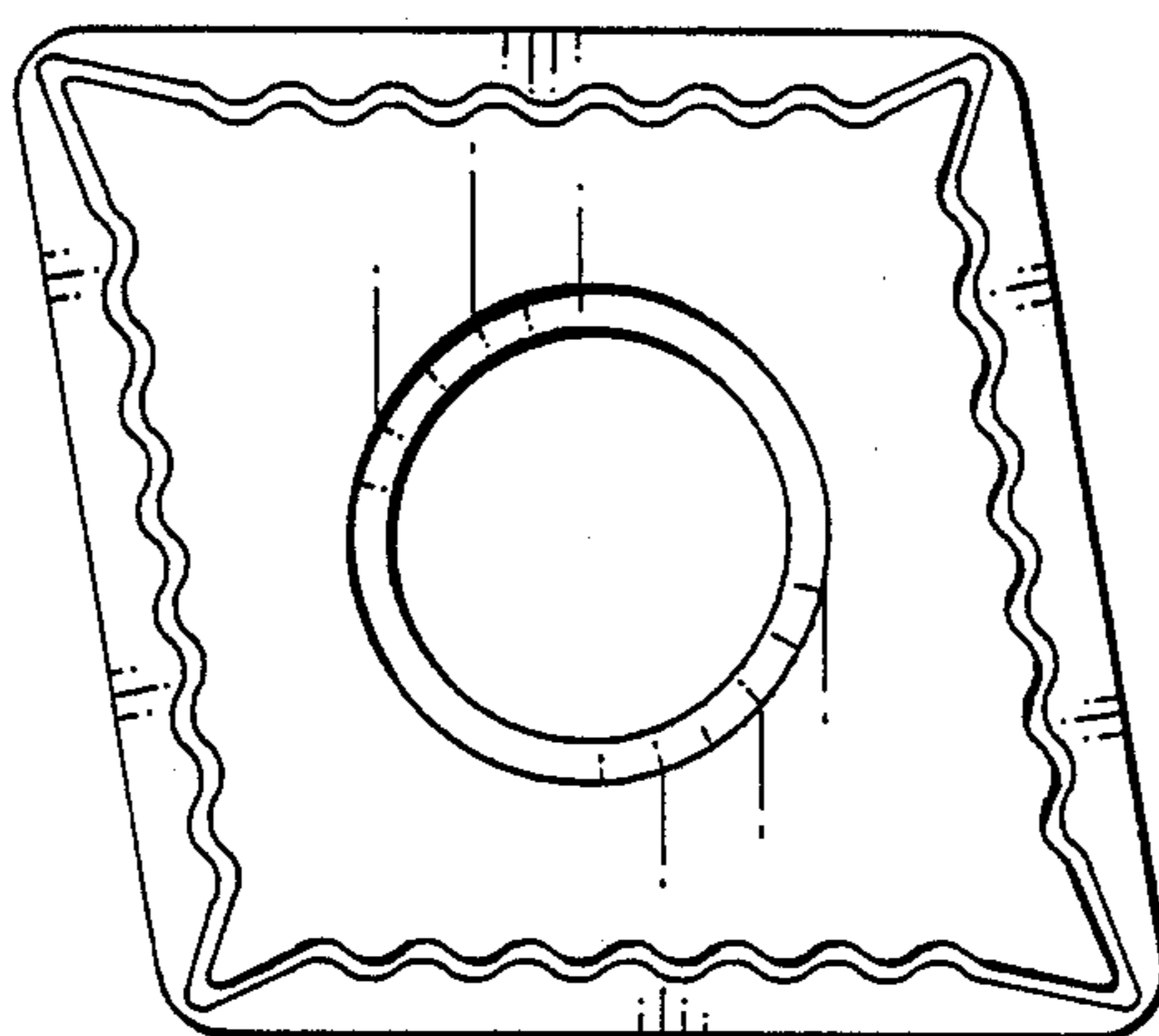

FIG. 19

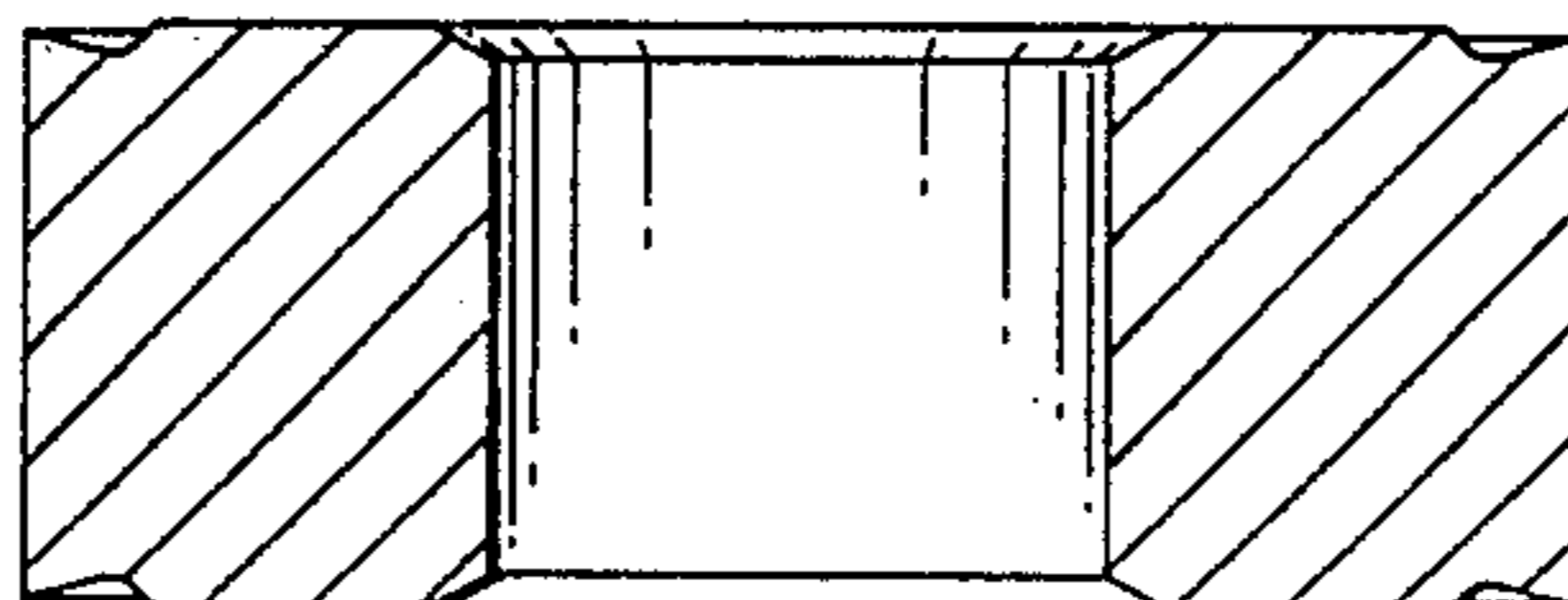

FIG. 20