

[54] COMBINED BOAT AND LUGGAGE CARRIER

[76] Inventor: Loren C. Kienlen, 1800 Lakewood Park, No. 144, Eugene, Oreg. 97402

[**] Term: 14 Years

[21] Appl. No.: 140,375

[22] Filed: Jan. 4, 1988

[52] U.S. Cl. D12/300; D12/157

[58] Field of Search D12/300, 302, 157, 102; 114/352, 353; 224/309, 328, 42.01

[56] References Cited

U.S. PATENT DOCUMENTS

D. 244,015	4/1977	Grind	D12/300
D. 268,101	3/1983	Pope et al.	D12/102
D. 291,193	8/1987	Hanek	D12/300
D. 297,134	8/1988	Levine	D12/157
4,522,145	6/1985	Stone	114/352
4,790,256	12/1988	Levine	114/352
4,794,876	1/1989	Levine	114/353

Primary Examiner—James M. Gandy
Assistant Examiner—Kay H. Chin

[57] CLAIM

The ornamental design for a combined boat and luggage carrier, as shown and described.

DESCRIPTION

FIG. 1 is a perspective view of a combined boat and luggage carrier in unfolded condition showing my new design;

FIG. 2 is a top plan view thereof;

FIG. 3 is a side elevational view thereof, the opposite side view being a mirror image of that shown;

FIG. 4 is a rear elevational view thereof;

FIG. 5 is a front elevational view thereof;

FIG. 6 is a bottom plan view thereof;

FIG. 7 is a top plan view thereof in folded condition;

FIG. 8 is a side elevational view of FIG. 7, the opposite side view being a mirror image of that shown;

FIG. 9 is a bottom plan view of FIG. 7;

FIG. 10 is a rear elevational view of FIG. 7; and

FIG. 11 is a front elevational view of FIG. 7.

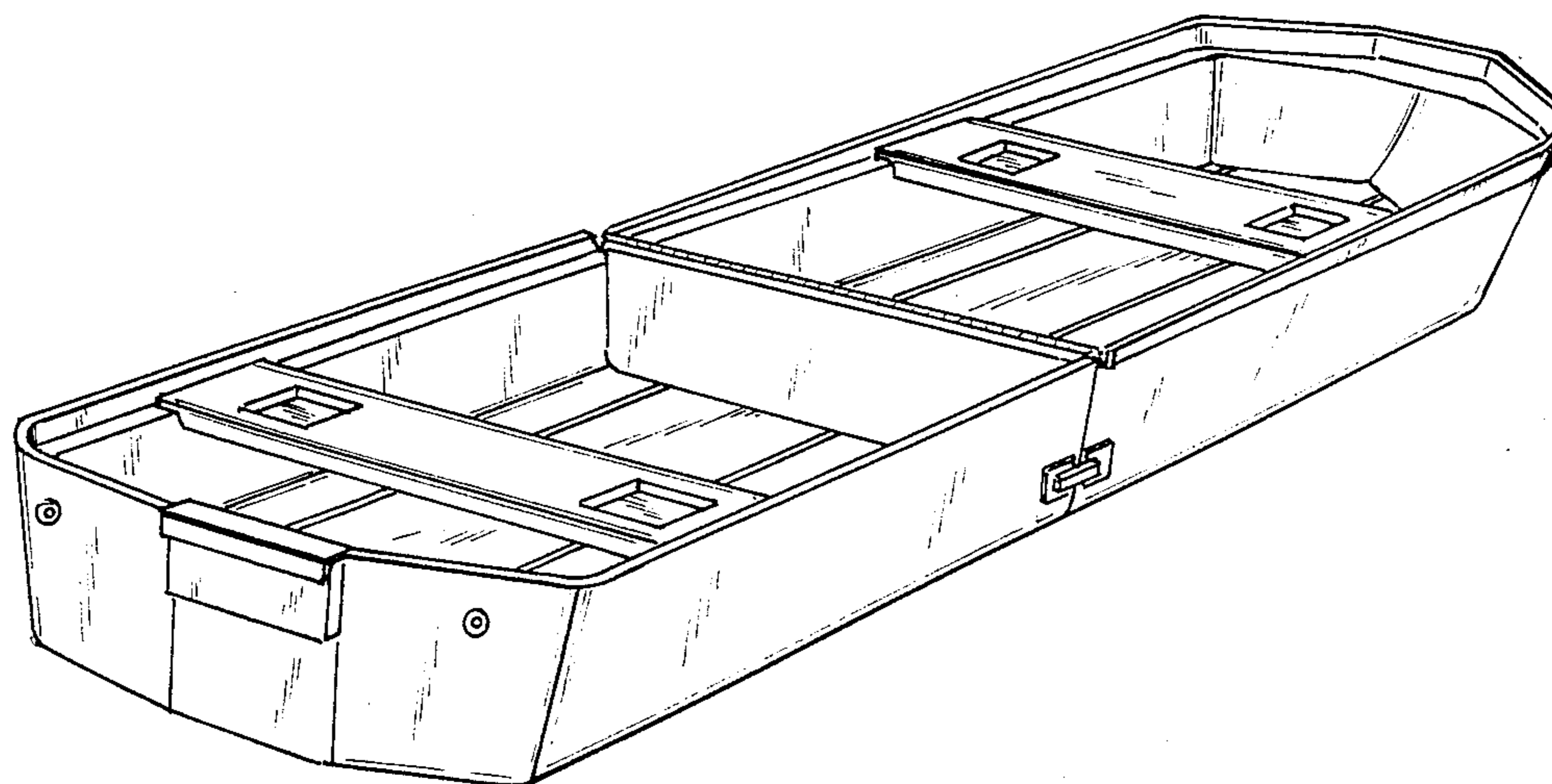

FIG. 1

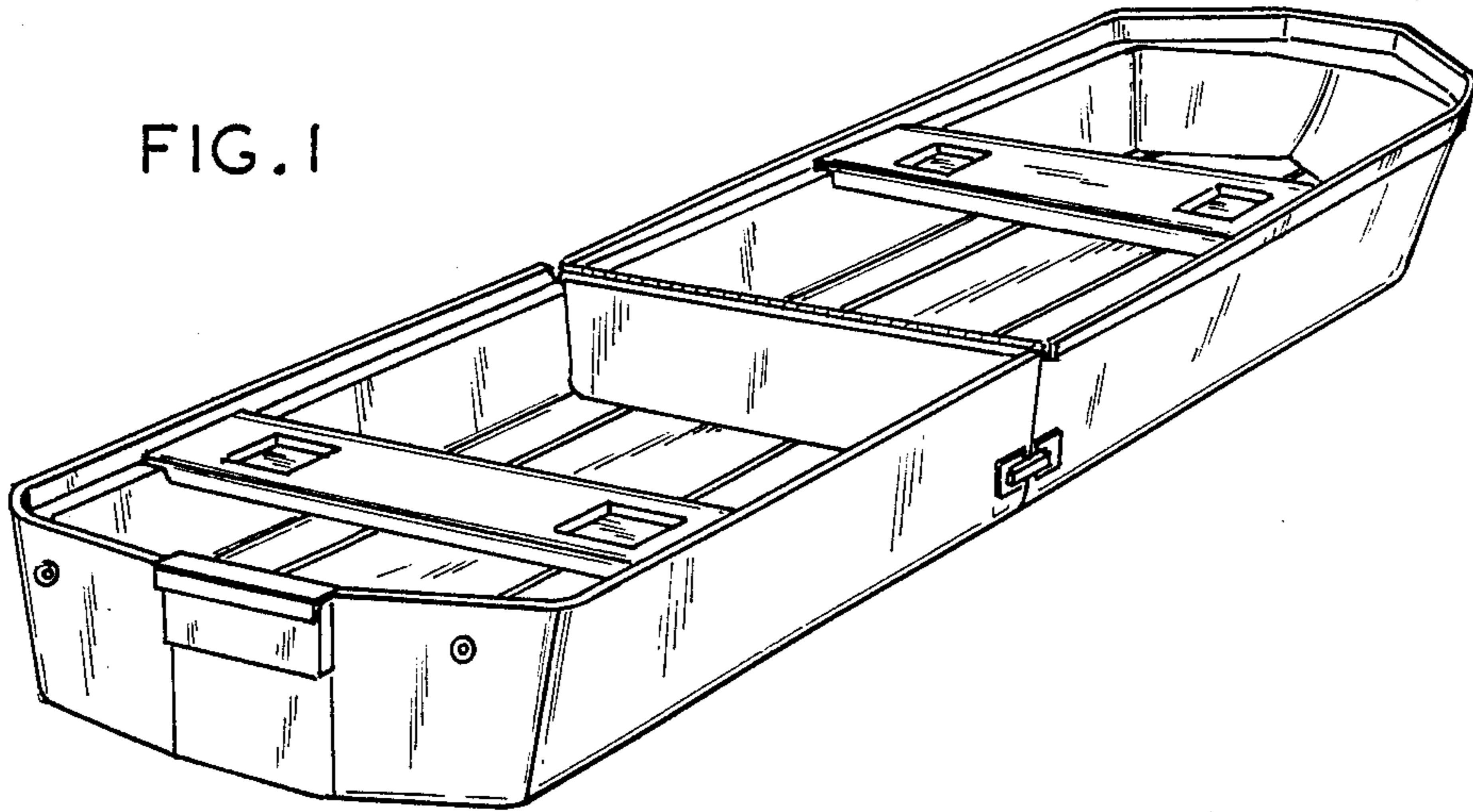

FIG. 2

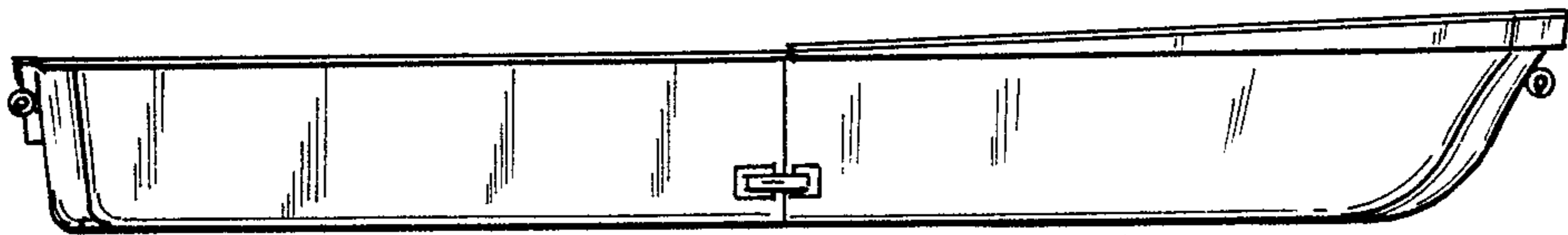
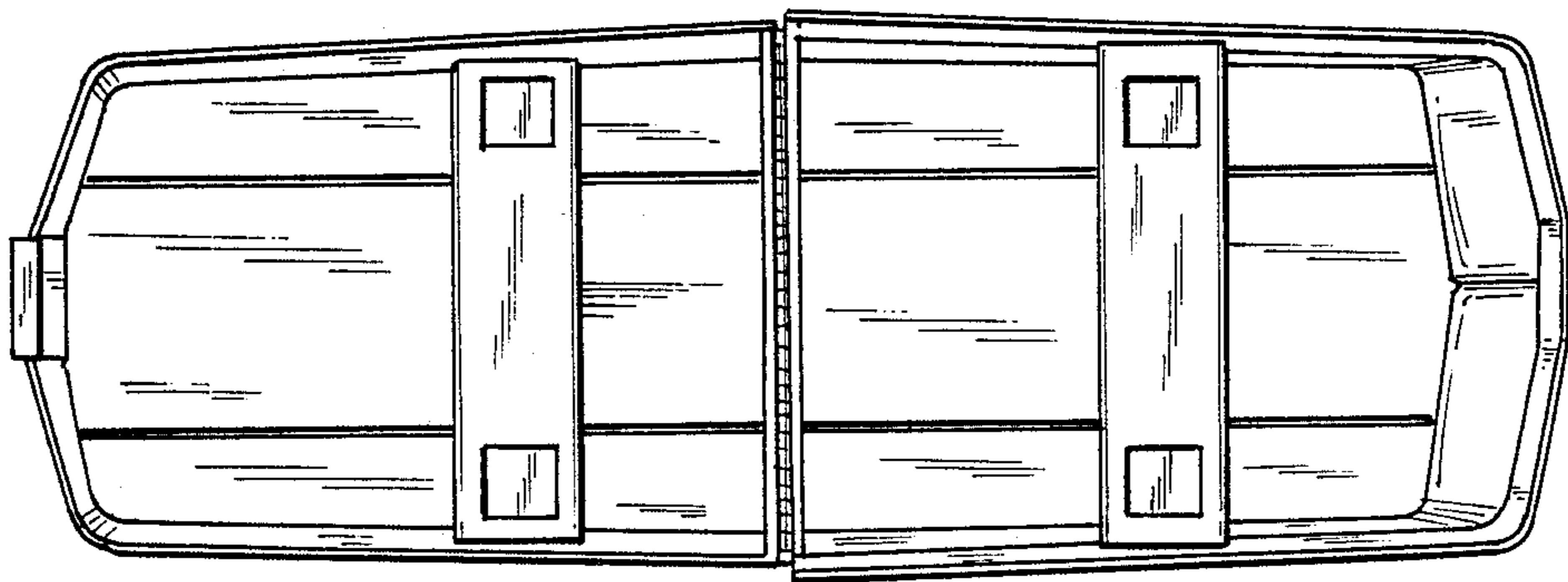

FIG. 3



FIG. 4

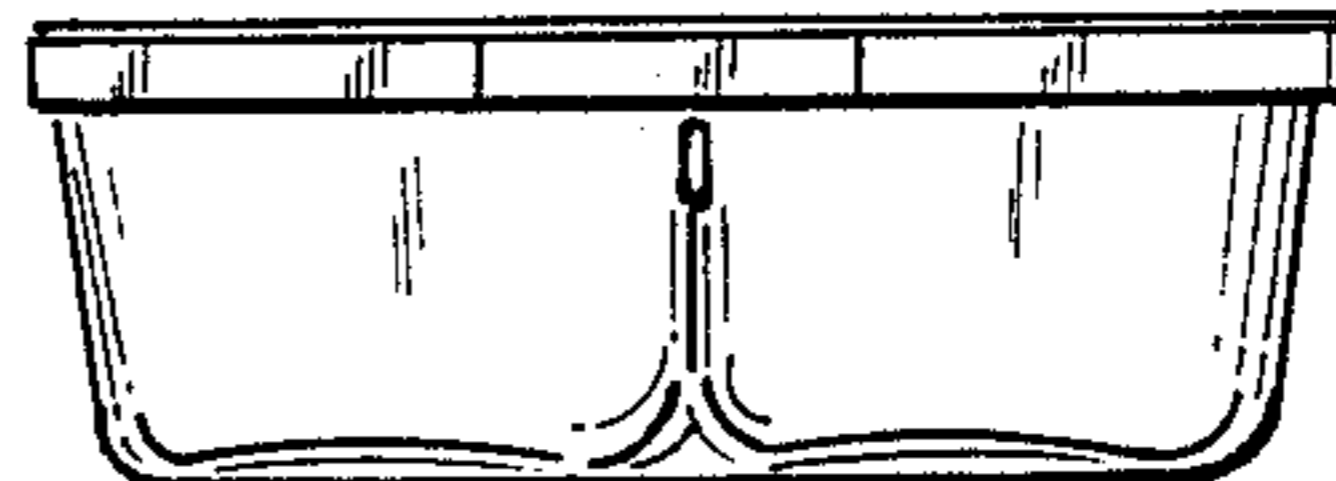

FIG. 5

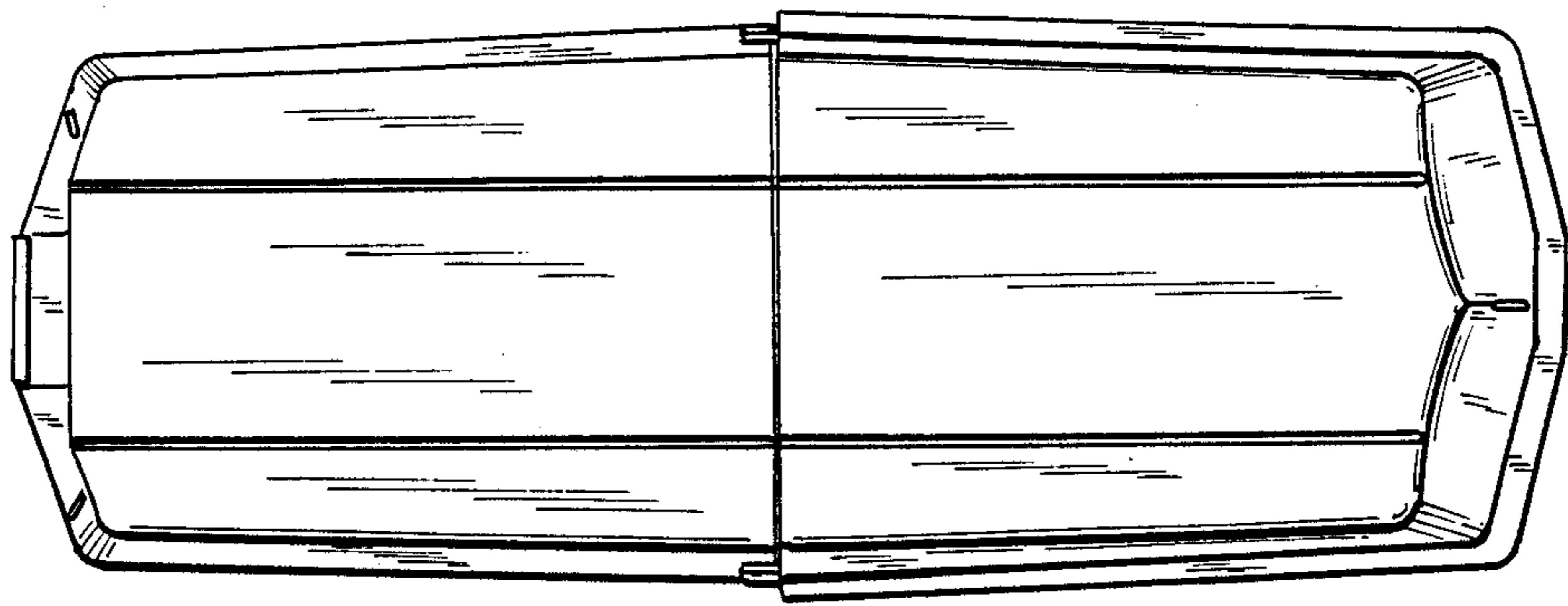

FIG. 6

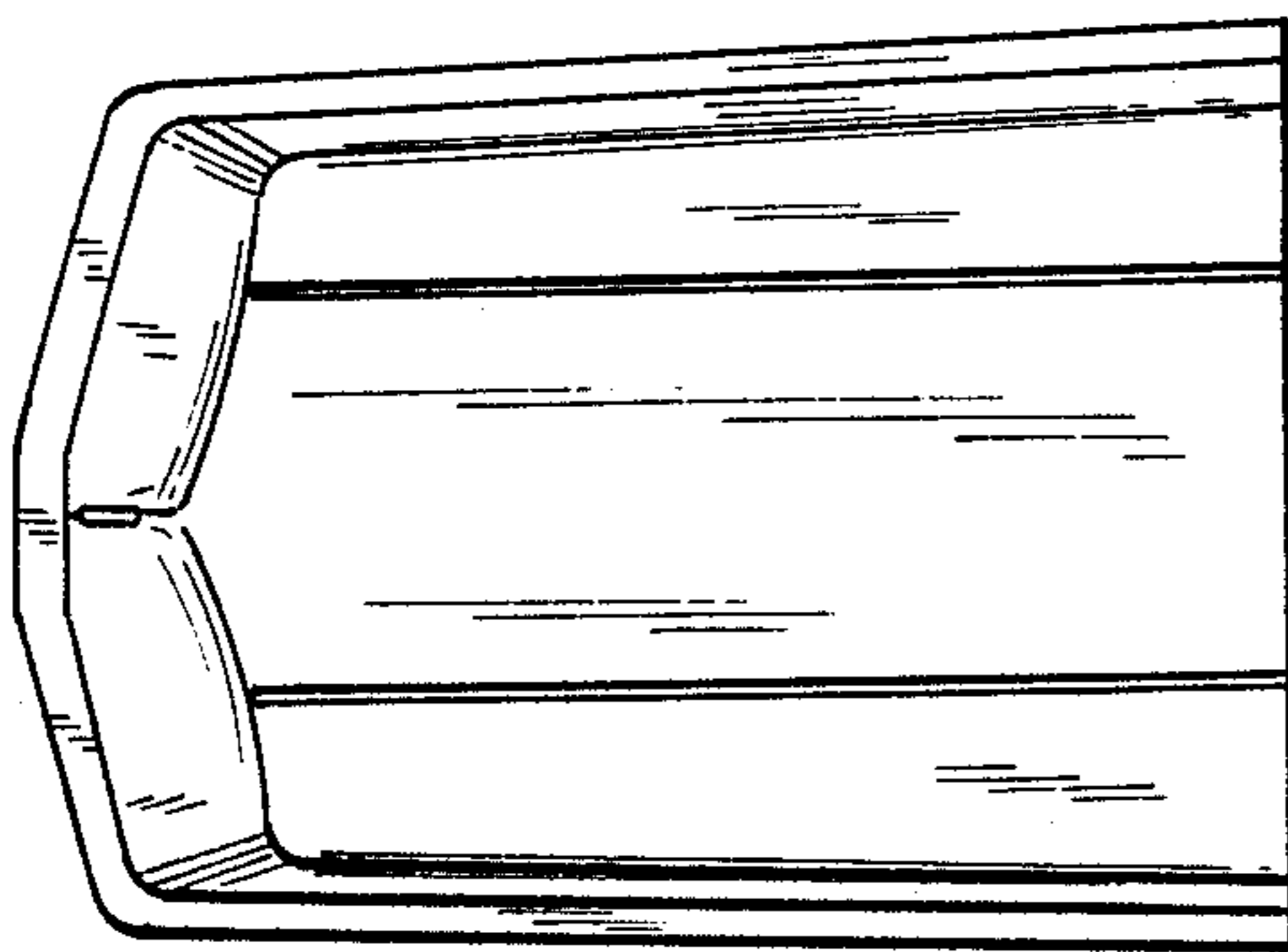

FIG. 7

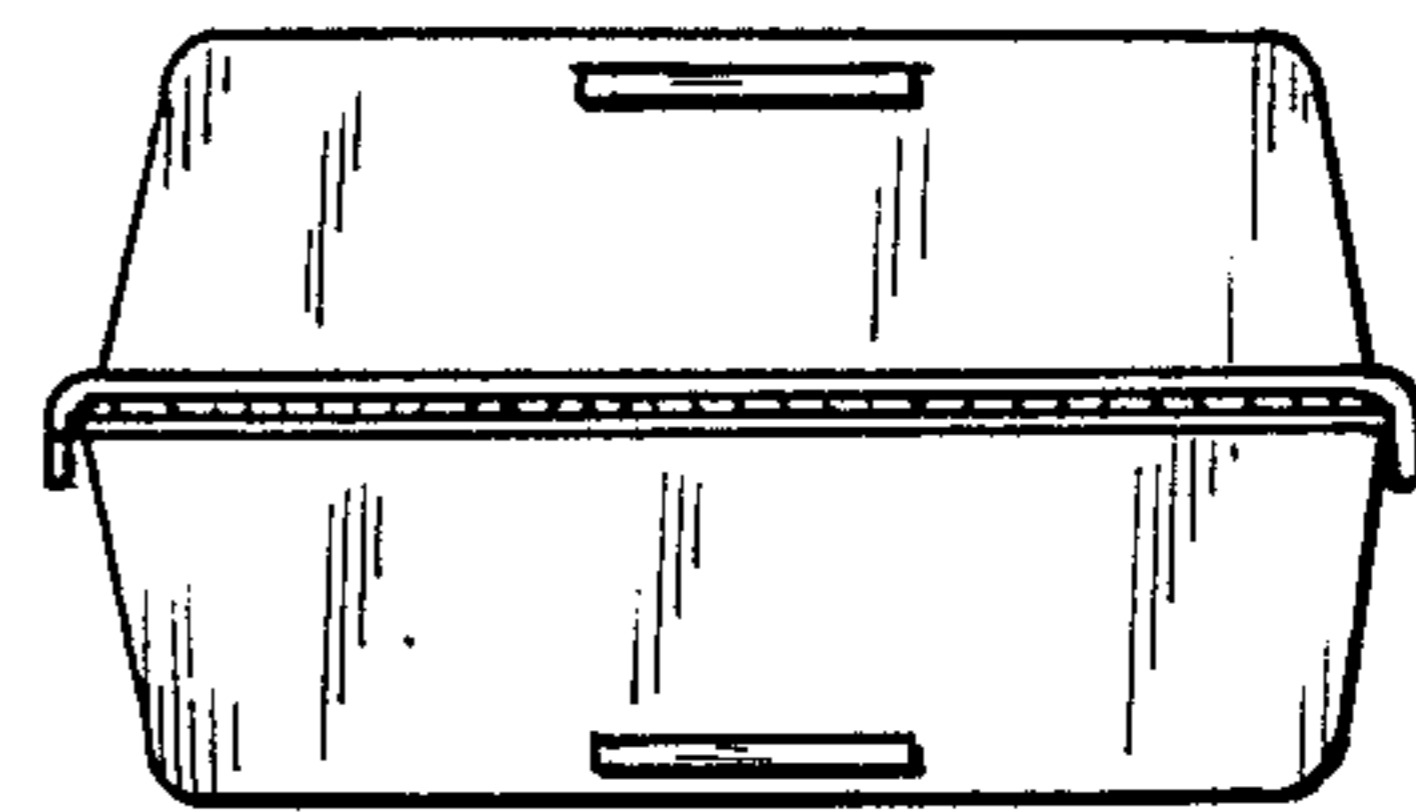

FIG. 10

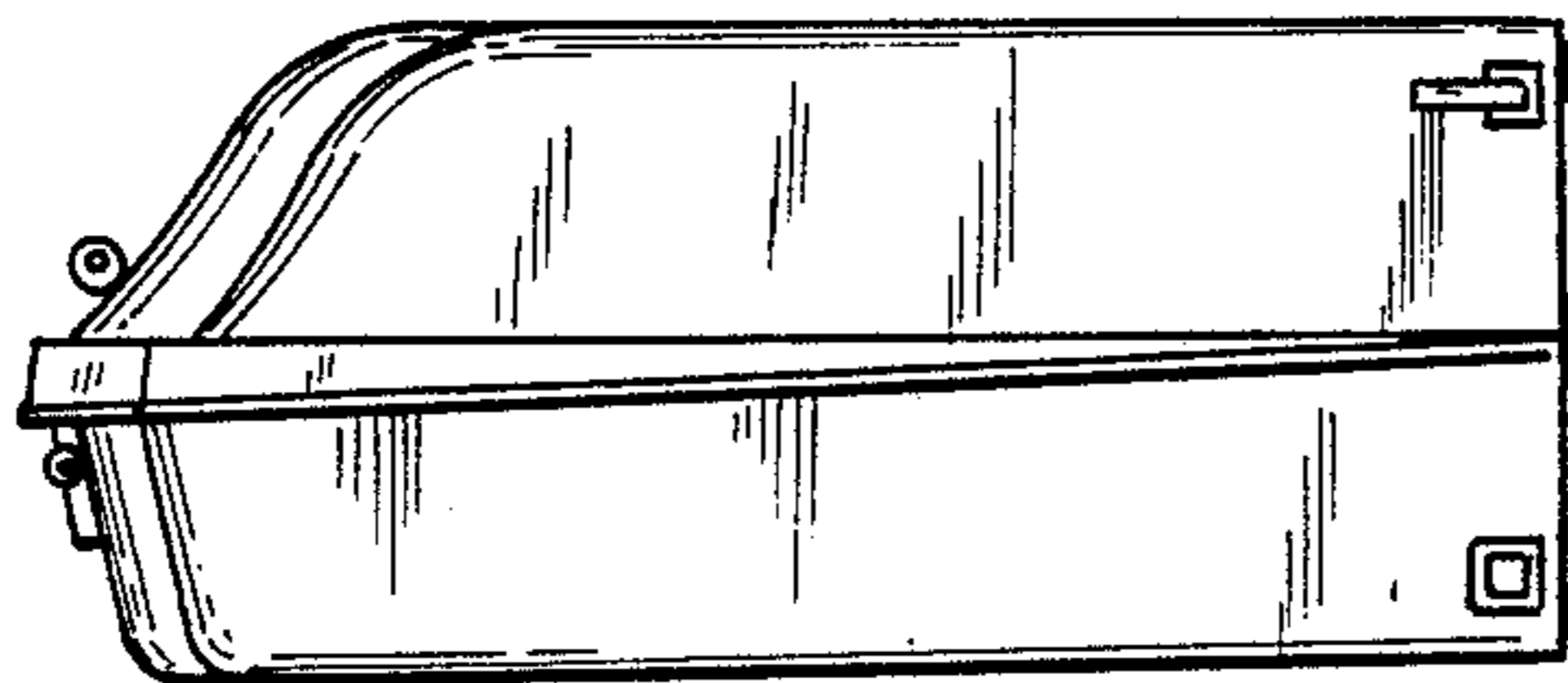

FIG. 8

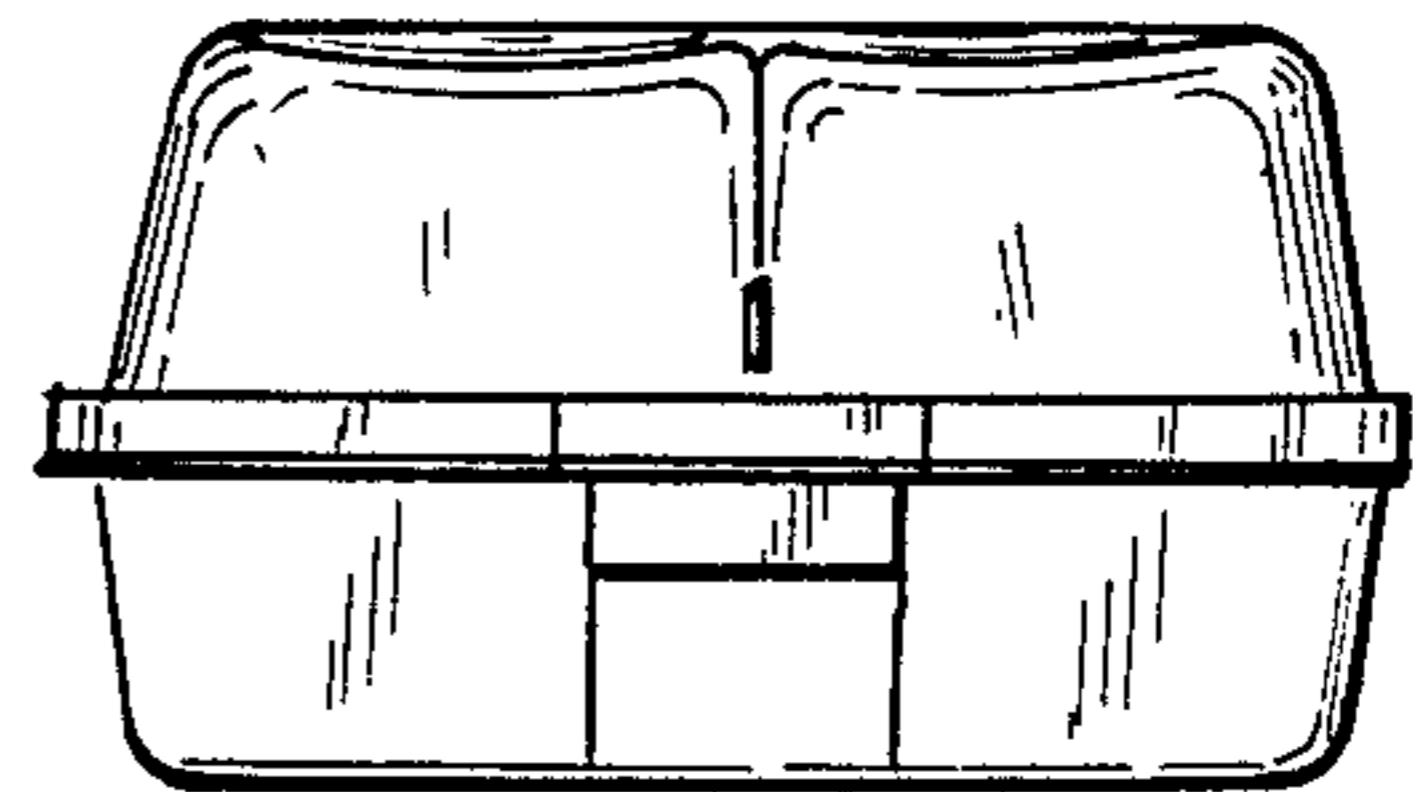

FIG. 11

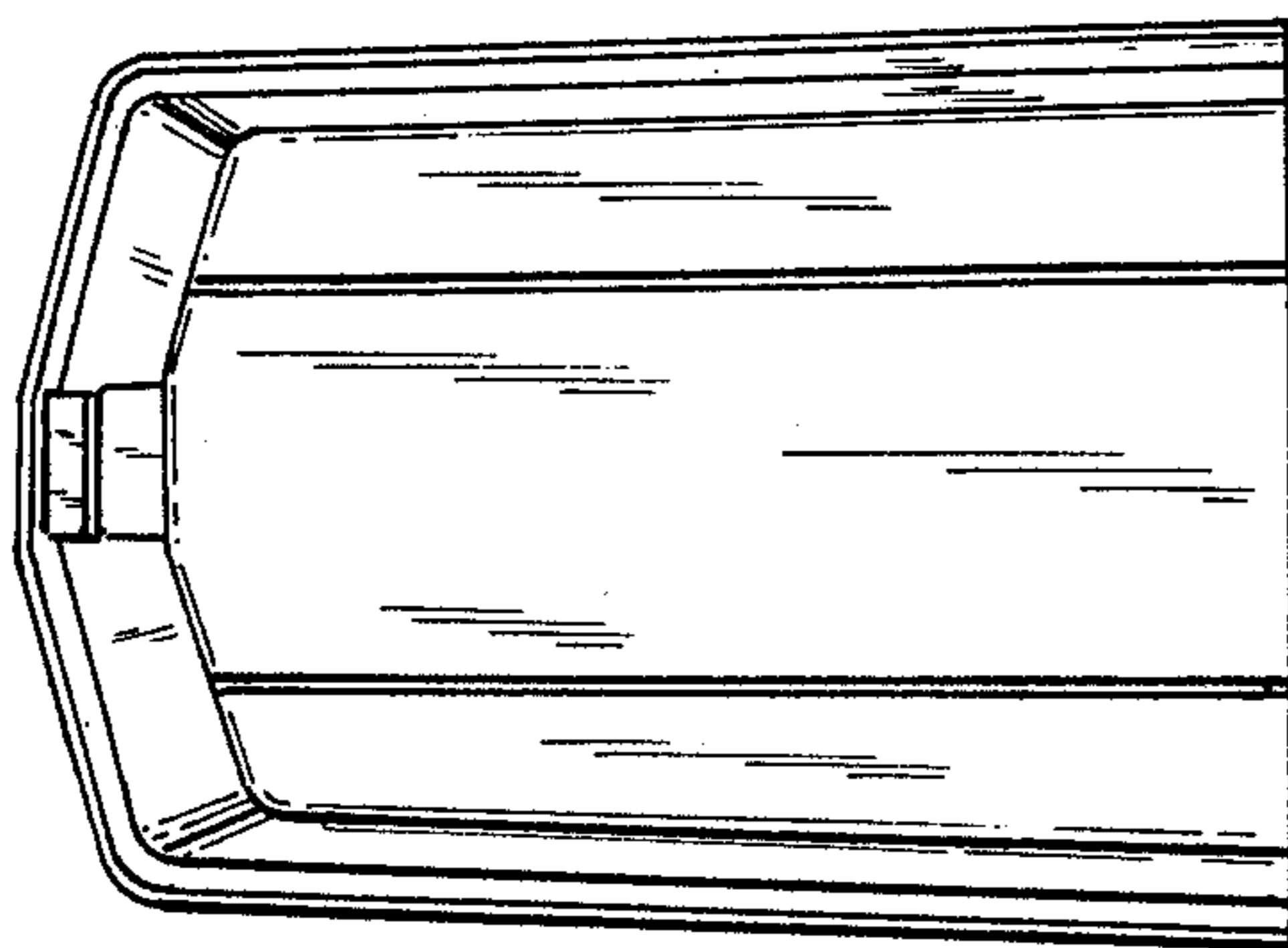

FIG. 9