

[54] **EXTERIOR EXTENSION FOR A TRUCK CAB**

[75] **Inventor: Richard J. Kingsley, N. Bonneville, Wash.**

[73] **Assignee: Saturn Corporation, Tacoma, Wash.**

[**] **Term: 14 Years**

[21] **Appl. No.: 915,325**

[22] **Filed: Oct. 3, 1986**

[52] **U.S. Cl. D12/156; D12/190**

[58] **Field of Search D12/156, 181, 190, 196; D26/34; 280/756; 362/61, 74**

[56] **References Cited**

U.S. PATENT DOCUMENTS

- D. 286,143 10/1986 Lund D12/156
- D. 295,084 4/1988 Weber D12/156

- 4,192,427 3/1980 Bergman 362/61
- 4,515,393 5/1985 Sauter 362/74

Primary Examiner—James M. Gandy
Attorney, Agent, or Firm—Cassidy & Vance

[57] **CLAIM**

The ornamental design for an exterior extension for a truck cab, as shown and described.

DESCRIPTION

FIG. 1 is a perspective view of an exterior extension for truck cabs showing my new design it being understood that the broken lines are for illustrative purposes only and form no part of the claimed design; FIG. 2 is a front elevation view thereof; FIG. 3 is a rear elevation view thereof; FIG. 4 is a top plan view thereof; FIG. 5 is a bottom plan view thereof; and, FIG. 6 is a side elevation view thereof.

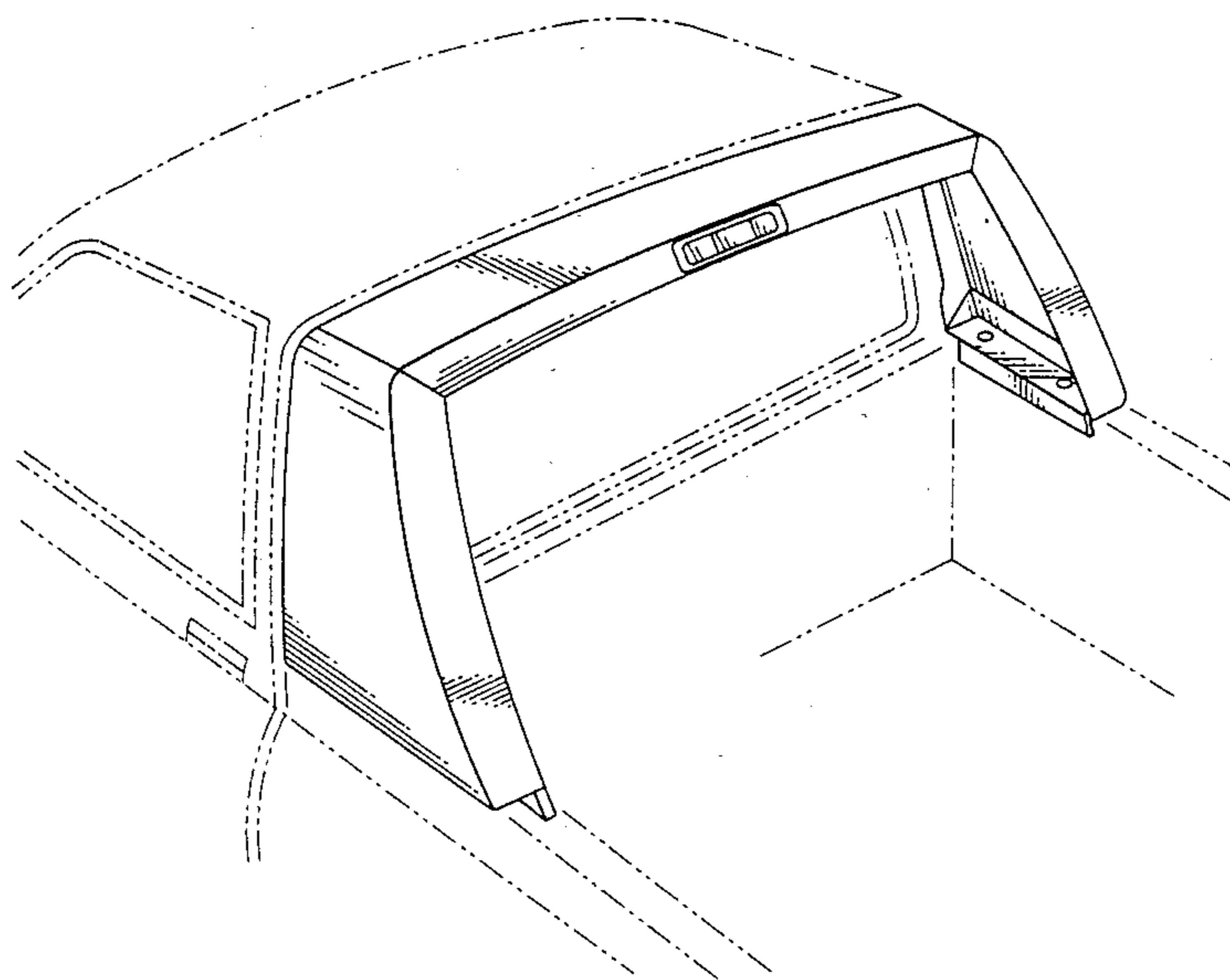

FIG. 1

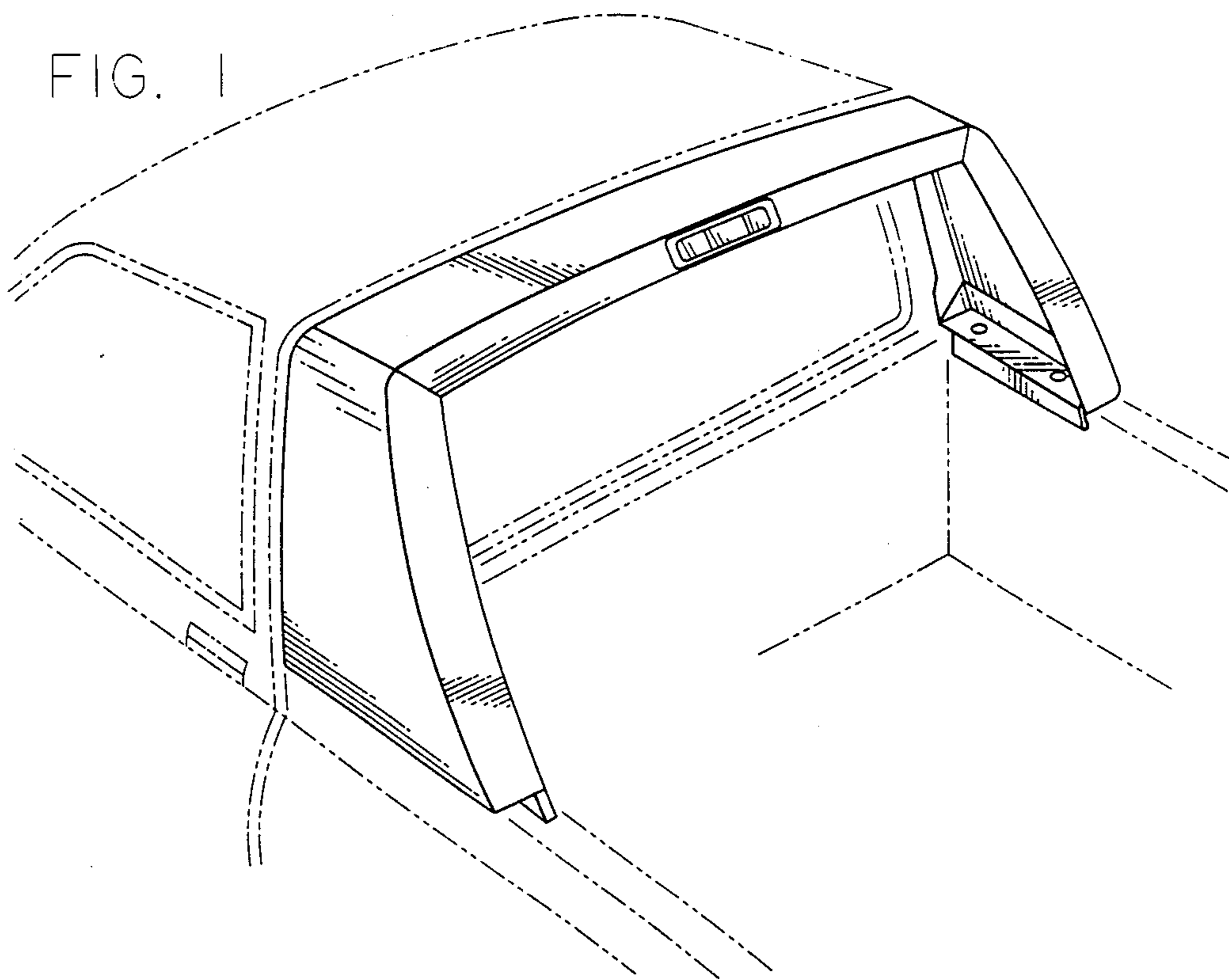

FIG. 2

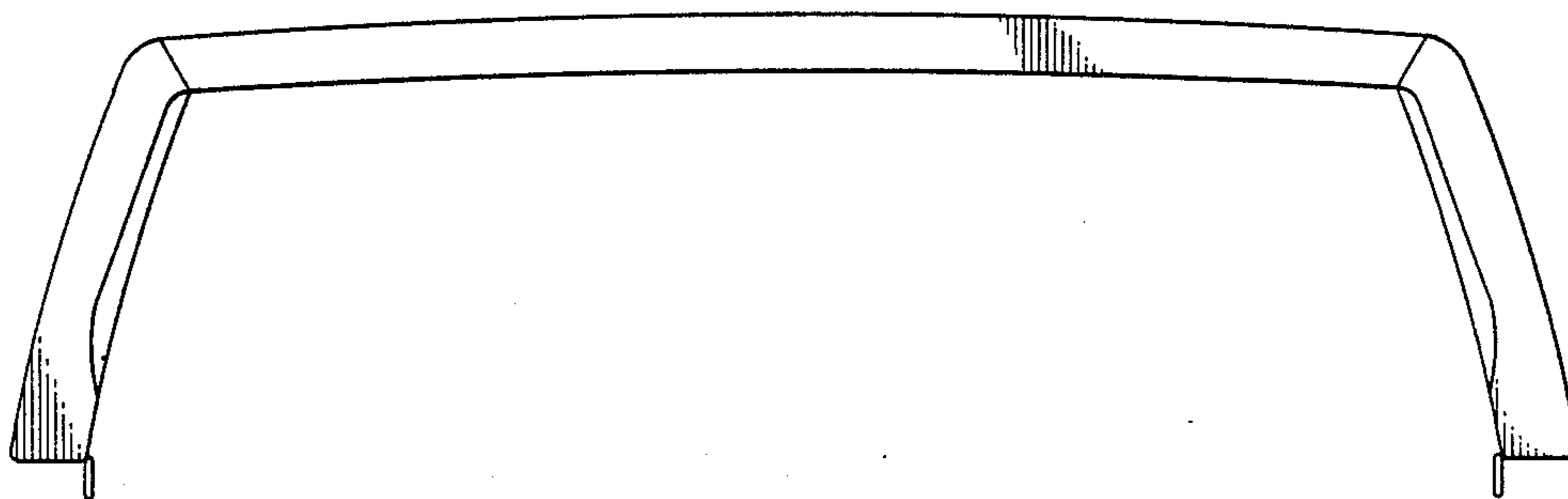

FIG. 3.

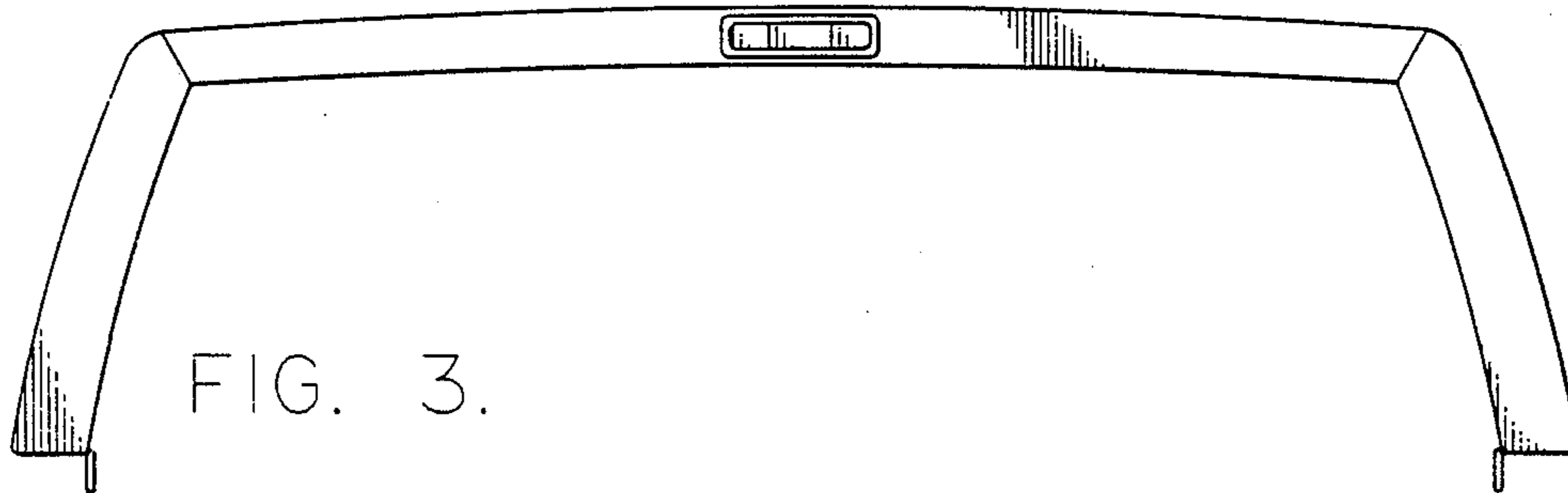

FIG. 4

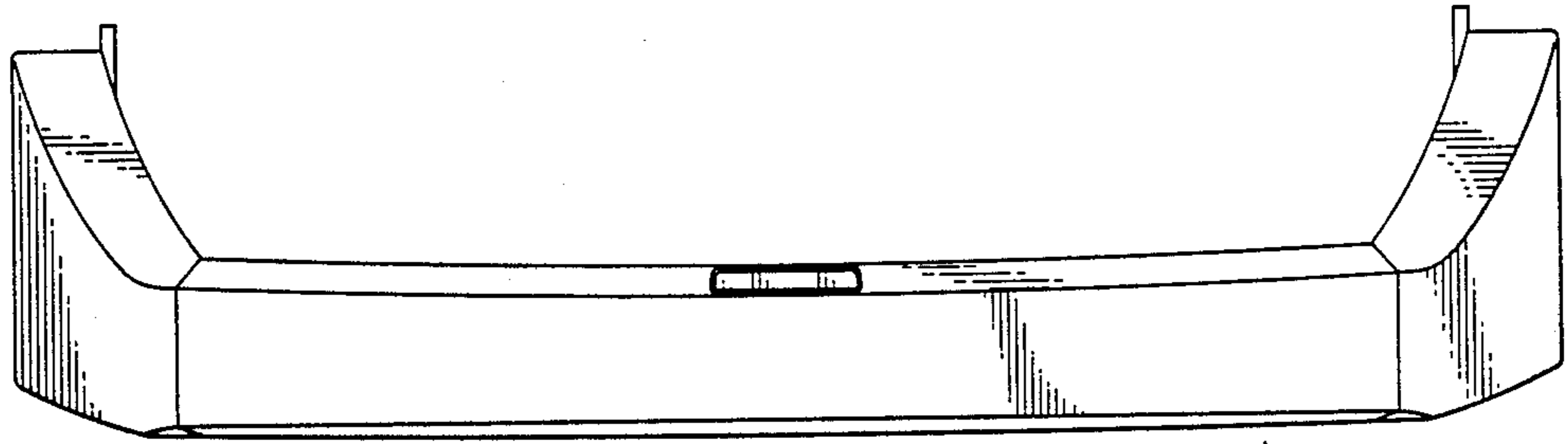

FIG. 5

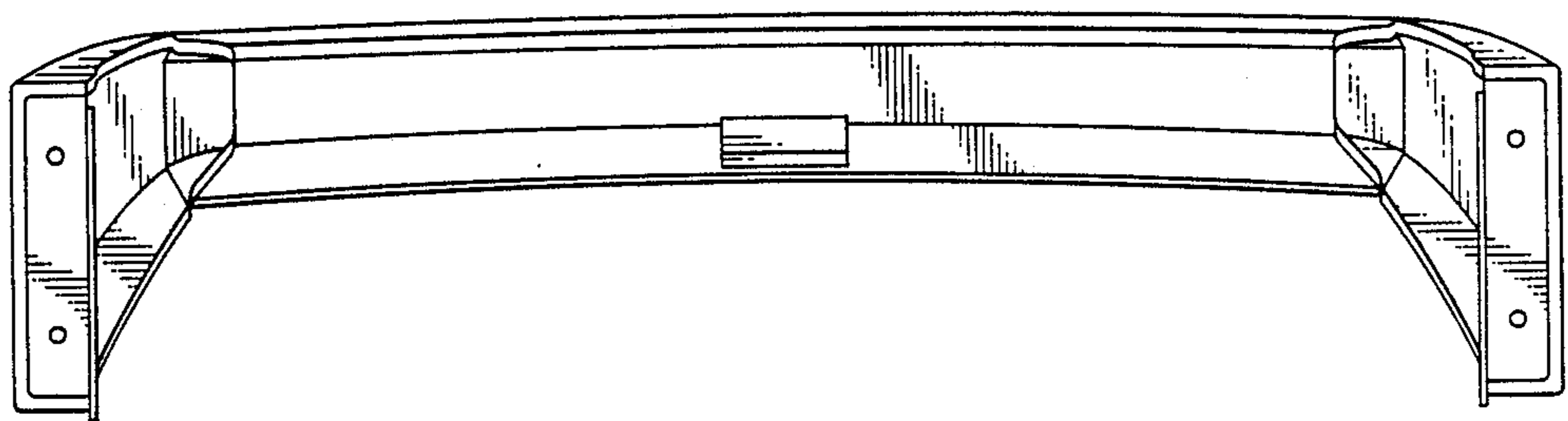

FIG. 6

