

[54] BUS

[75] Inventors: Joseph Gallitzendoerfer; Bruno Sacco, both of Sindelfingen; Peter Pfeiffer, Boeblingen; Gerhard Steinle, Gechingen, all of Fed. Rep. of Germany

[73] Assignee: Daimler-Benz AG, Stuttgart, Fed. Rep. of Germany

[\*\*] Term: 14 Years

[21] Appl. No.: 936,266

[22] Filed: Dec. 1, 1986

[30] Foreign Application Priority Data

May 30, 1986 [DE] Fed. Rep. of Germany ..... MR 6090

[52] U.S. Cl. .... D12/84

[58] Field of Search ..... D12/84; 296/178

[56] References Cited

U.S. PATENT DOCUMENTS

- D. 236,968 9/1975 Armstrong et al. .... D12/84
- D. 268,997 5/1983 Dubernard ..... D12/84

OTHER PUBLICATIONS

Abitare, 9/81, p. 107, Bus, upper right side of page.

Primary Examiner—James M. Gandy  
Attorney, Agent, or Firm—Barnes & Thornburg

[57] CLAIM

The ornamental design for a bus, as shown and described.

DESCRIPTION

FIG. 1 is a perspective view from the left front of the bus embodying our novel design;  
 FIG. 2 is a left side elevational view thereof on a reduced scale, the right side being mirror-image-like;  
 FIG. 3 is a perspective view from the left rear thereof on a reduced scale;  
 FIG. 4 is a top plan view thereof on a reduced scale;  
 FIG. 5 is a rear elevational view thereof; and  
 FIG. 6 is a front elevational view thereof.

The characteristic features of my design reside in the lines resulting from the projections in the side walls of the bus and in the line resulting in the upper part of the side windows.

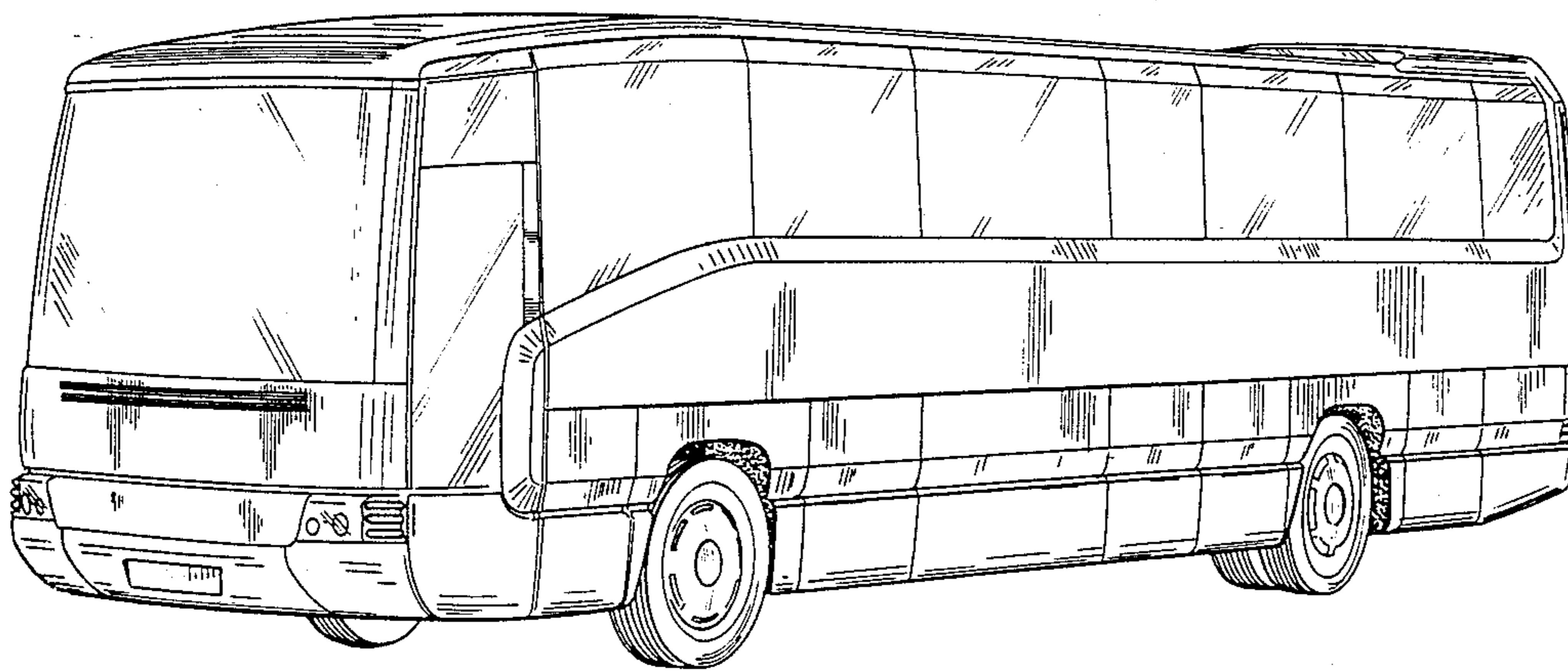

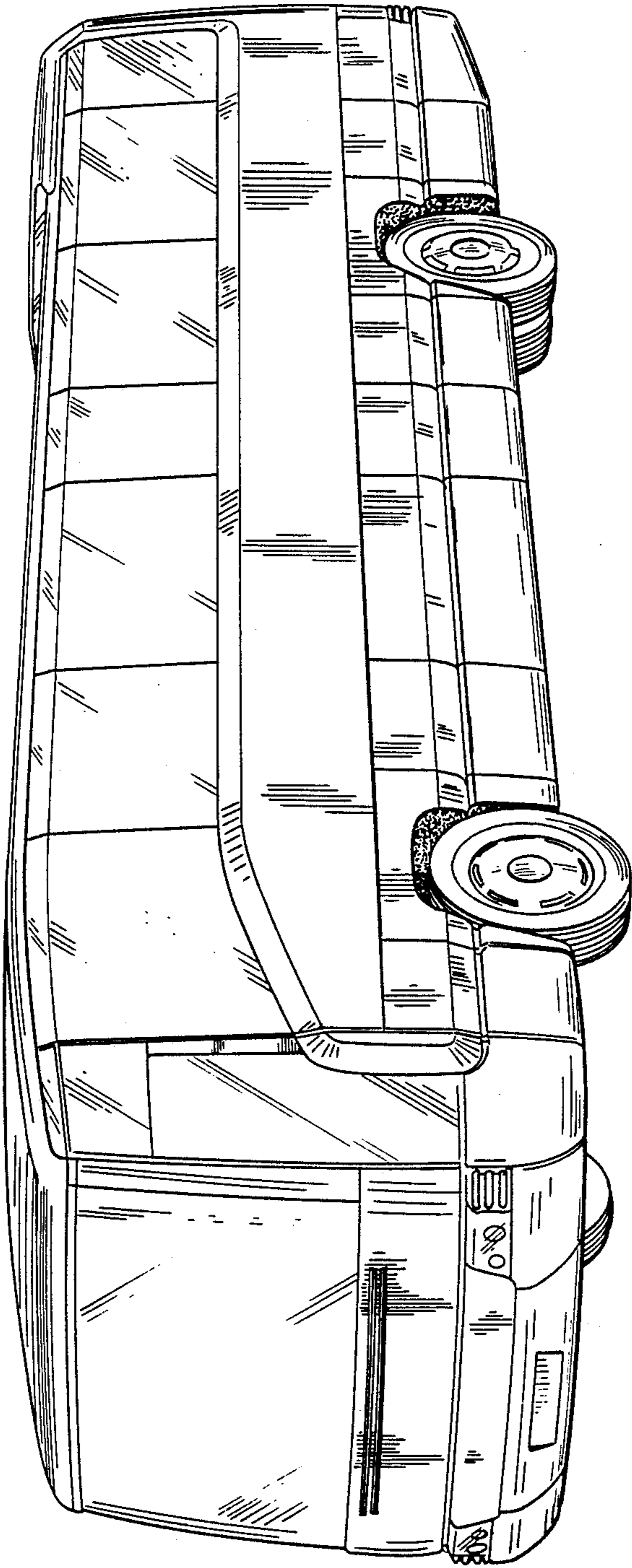

FIG. 1

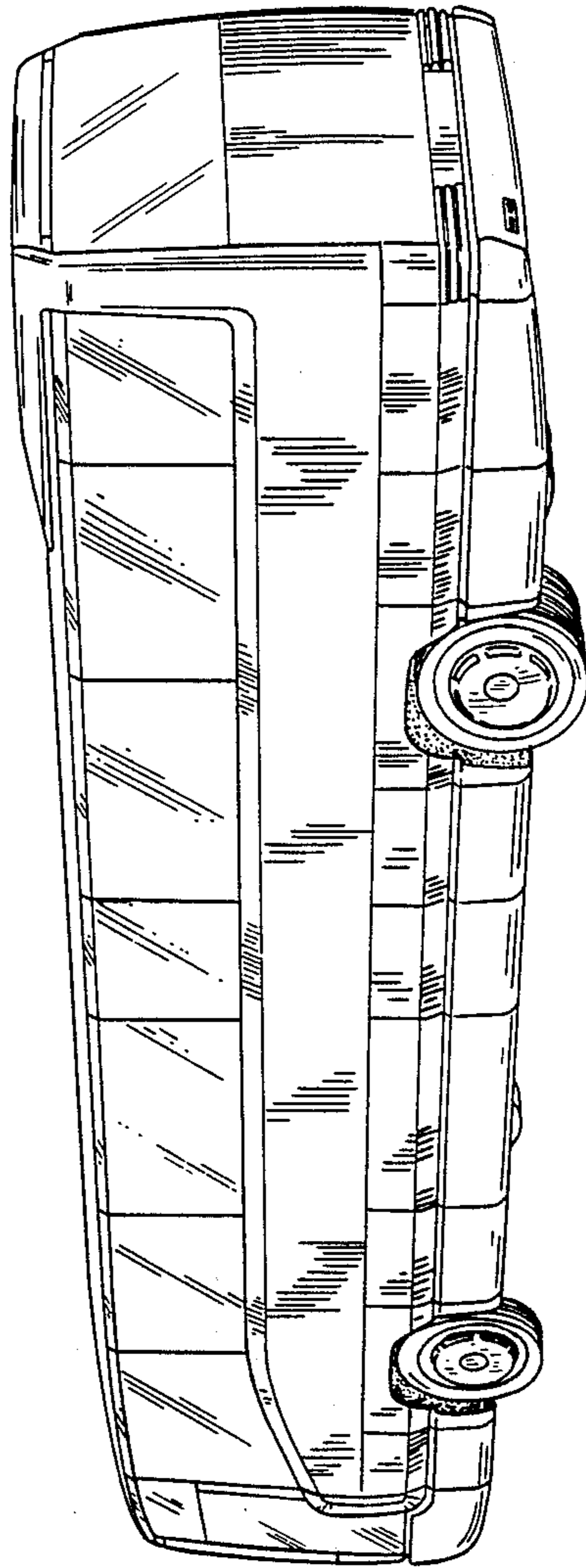

FIG. 3

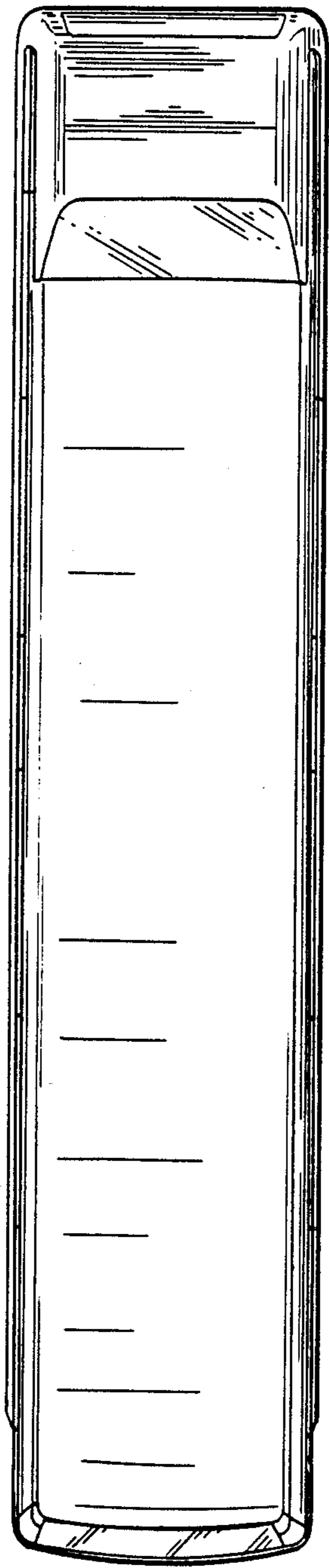

FIG. 4

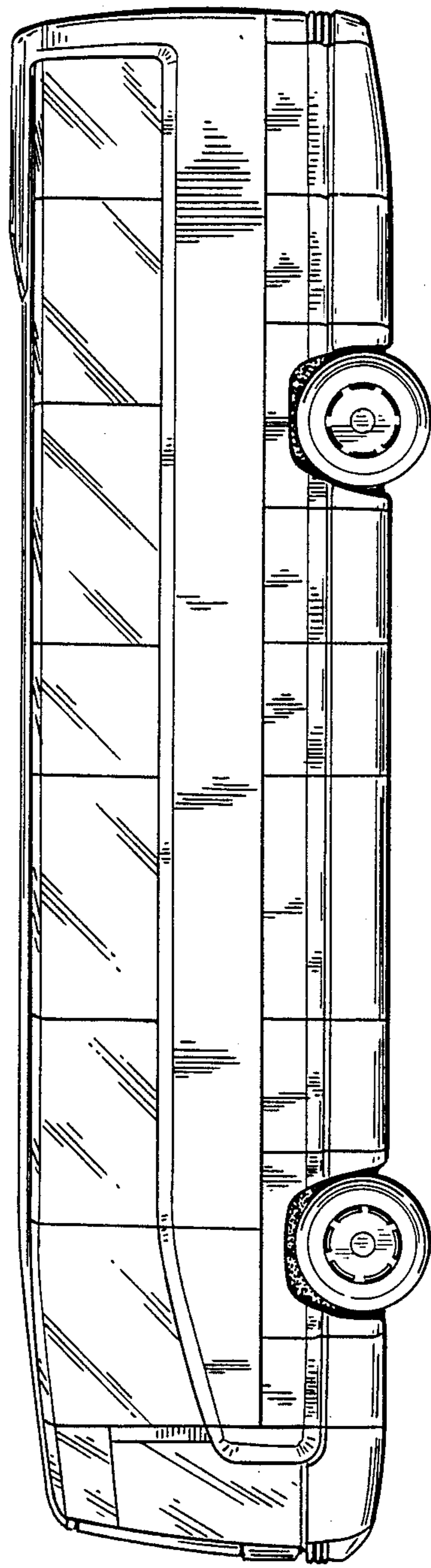
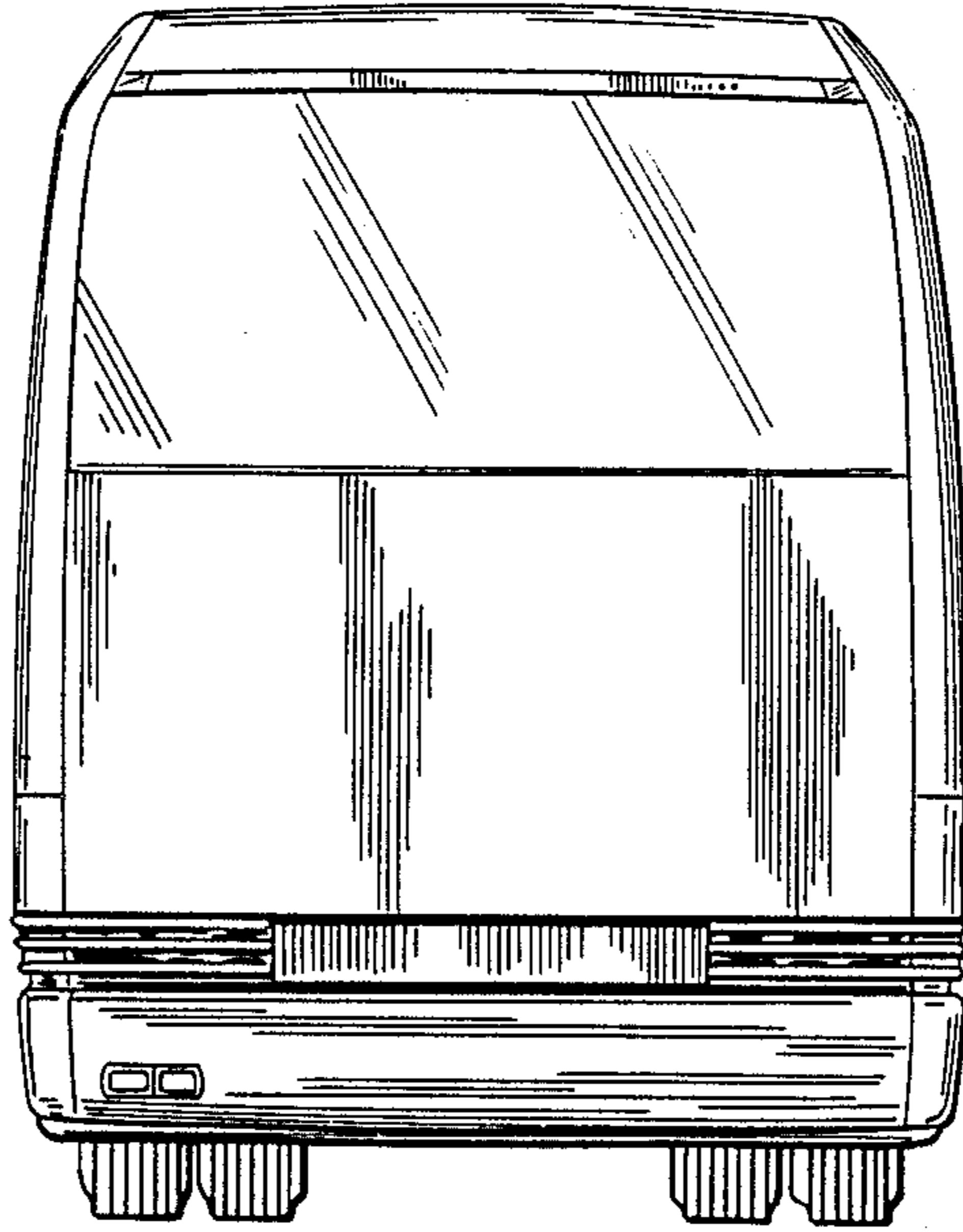
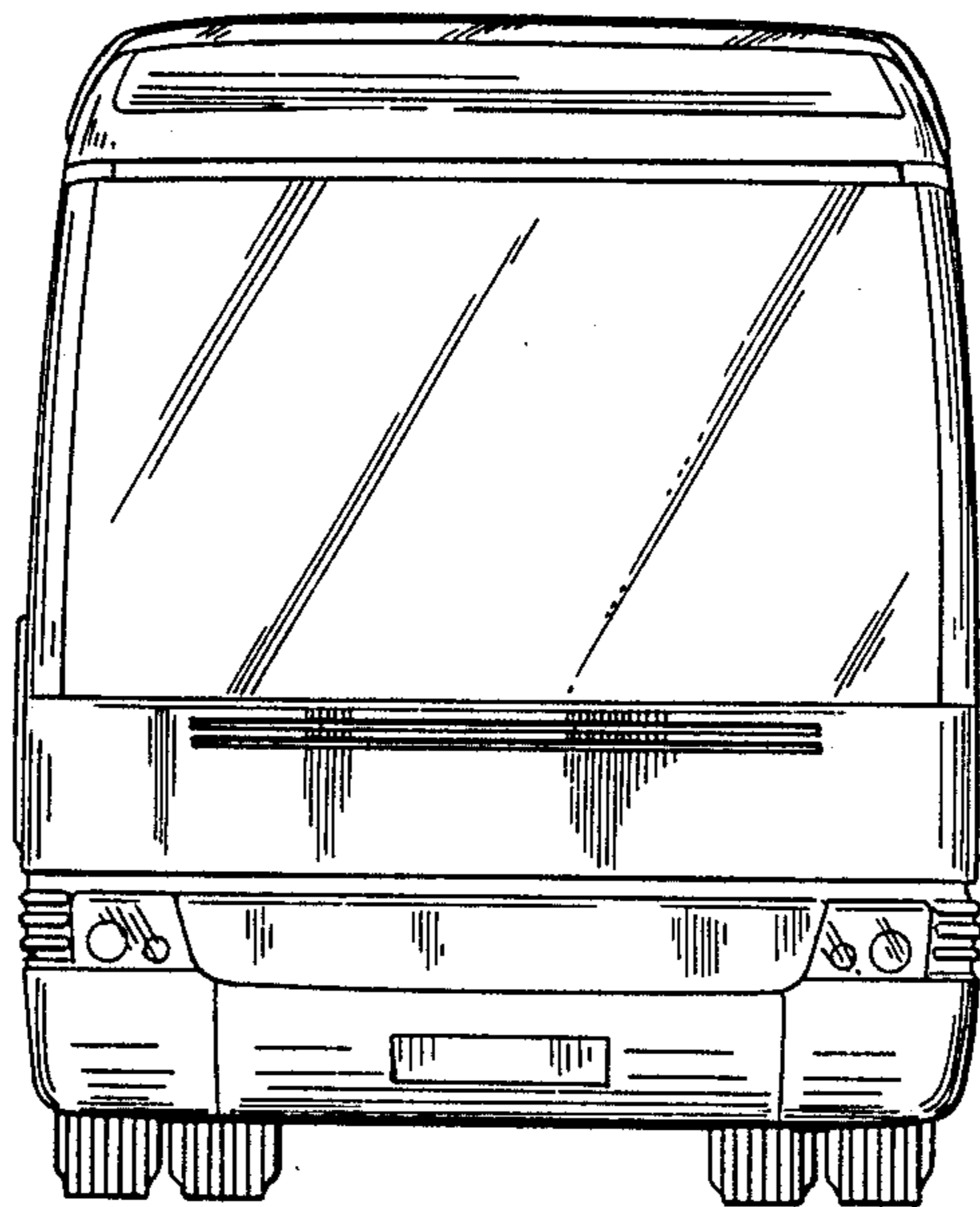

FIG. 2





*FIG. 5*



*FIG. 6*