

[54] EXTENDED WIDE STEP RUNNING BOARD FOR VAN OR TRUCK

[75] Inventors: James E. Anderson; Samuel R. Carlin, both of Sturgis, Mich.

[73] Assignee: Owens Products, Inc., Sturgis, Mich.

[**] Term: 14 Years

[21] Appl. No.: 65,522

[22] Filed: Jun. 23, 1987

[52] U.S. Cl. D12/203

[58] Field of Search D12/203; D25/69; 280/163, 169; 52/179, 181

[56] References Cited

U.S. PATENT DOCUMENTS

D. 257,532	11/1980	Okland	D12/203
D. 258,128	2/1981	Baker	D12/203
D. 261,133	10/1981	Makela	D12/203
D. 272,430	1/1984	Minichillo et al.	D12/203
D. 278,329	4/1985	Baker et al.	D12/203

OTHER PUBLICATIONS

J. C. Whitney Catalog No. 478J, ©1986, p. 69, Aluminum Running Board with Safety Step Rubber Inserts & High-Back Running Board, lower left & right side of page respectively.

Primary Examiner—James M. Gandy
Attorney, Agent, or Firm—Flynn, Thiel, Boutell & Tanis

[57] CLAIM

The ornamental design for an extended wide step running board for van or truck, as shown and described.

DESCRIPTION

FIG. 1 is a perspective view of an extended wide step running board for van or truck showing our new design; FIG. 2 is a top plan view thereof on a reduced scale; FIG. 3 is an end elevation view thereof on a reduced scale; FIG. 4 is a front elevation view thereof on a reduced scale; FIG. 5 is a rear elevation view thereof on a reduced scale; FIG. 6 is a bottom plan view thereof on a reduced scale; FIG. 7 is a perspective view of an extended wide step running board for van or truck showing a second embodiment of our new design the only differences being in the addition of a tubular illuminating strip extending along and facing downward and laterally outward from the enlarged top most groove thereof and a textured surfacing applied to and extending along the central horizontal portion of the running board; and FIG. 8 is a front elevation view of FIG. 7 on a reduced scale.

The running board has been broken away at the left end in FIGS. 2, 4, 5, 6 and 8 for convenience of illustration.

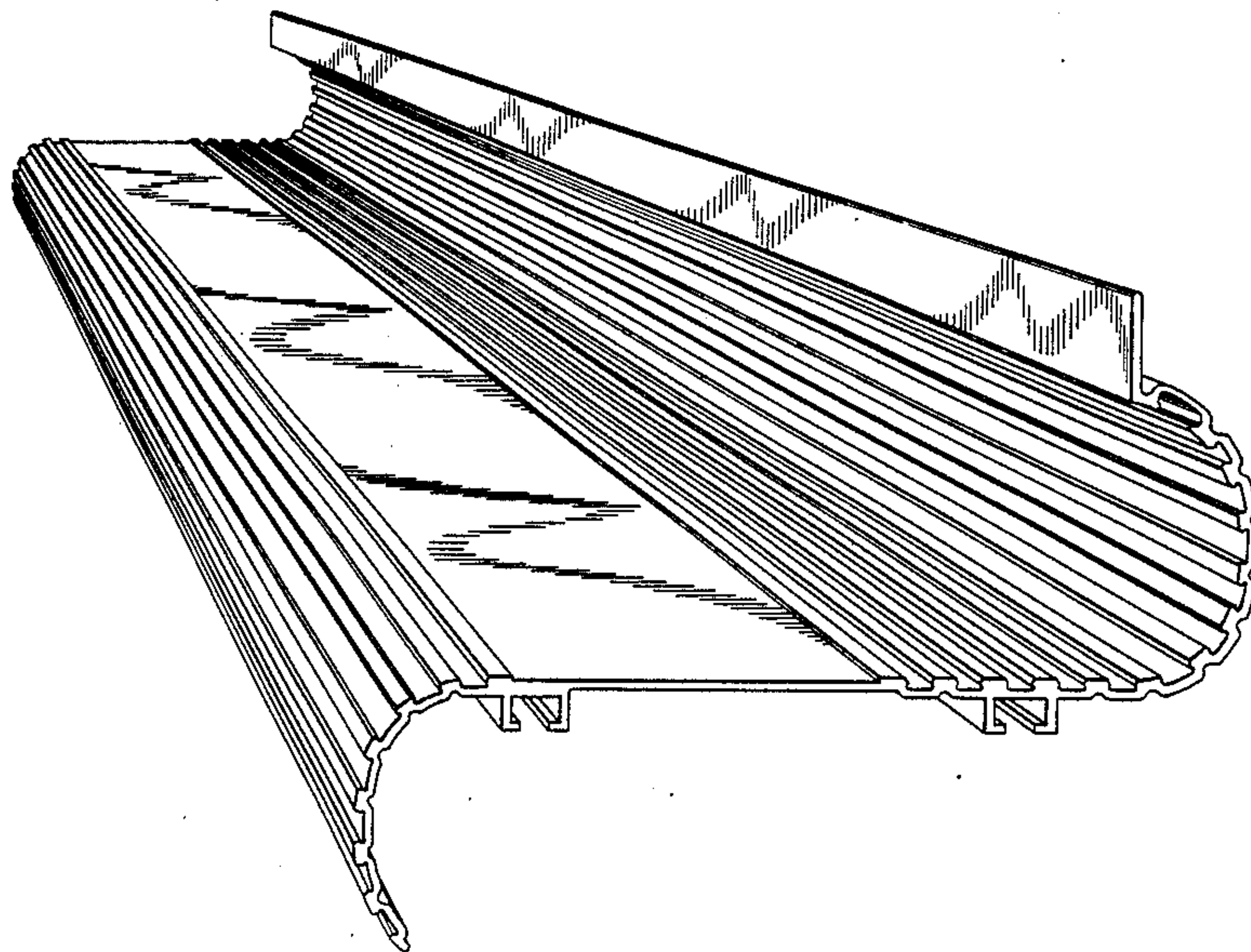

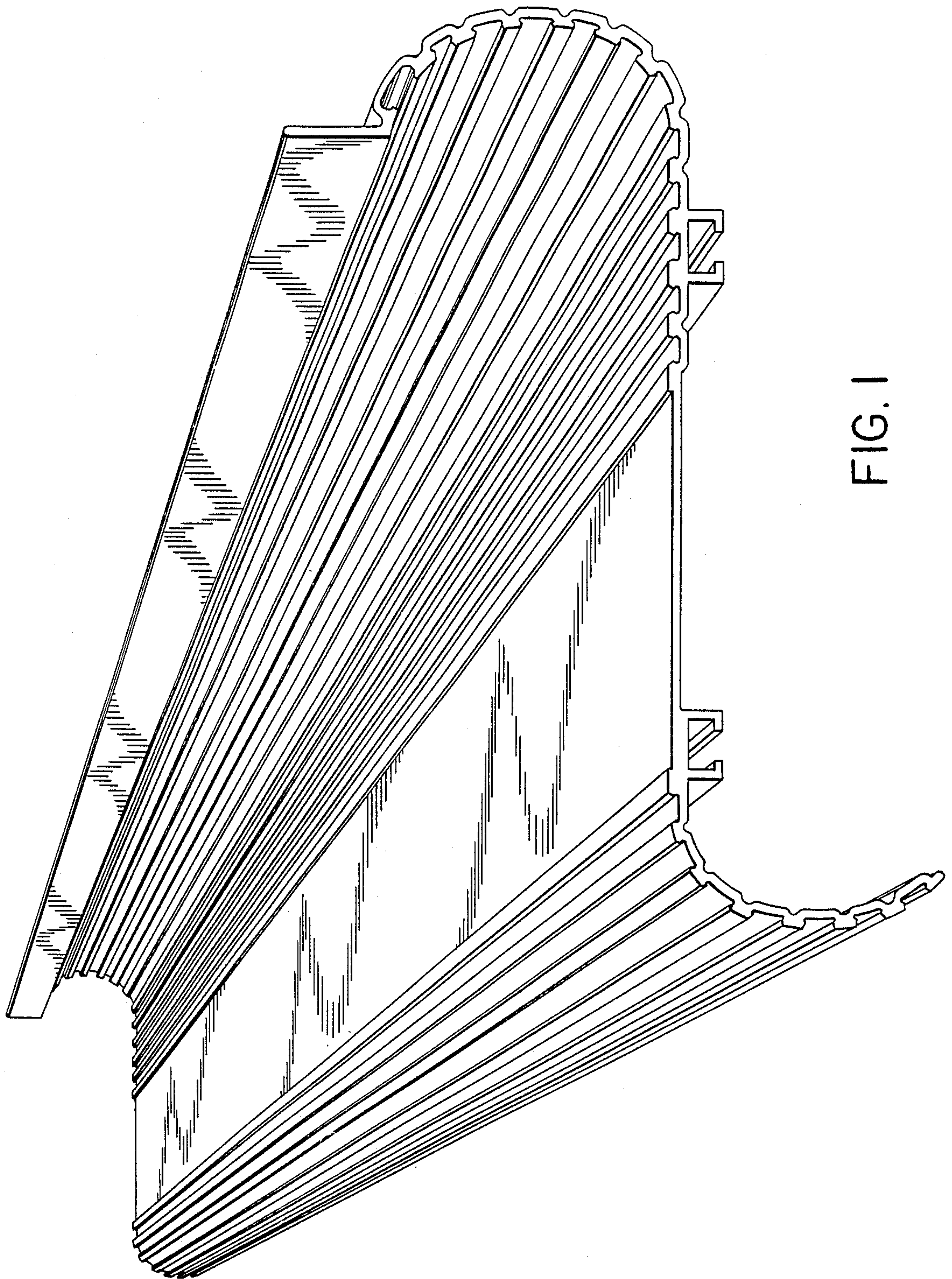

FIG. 1

FIG. 3

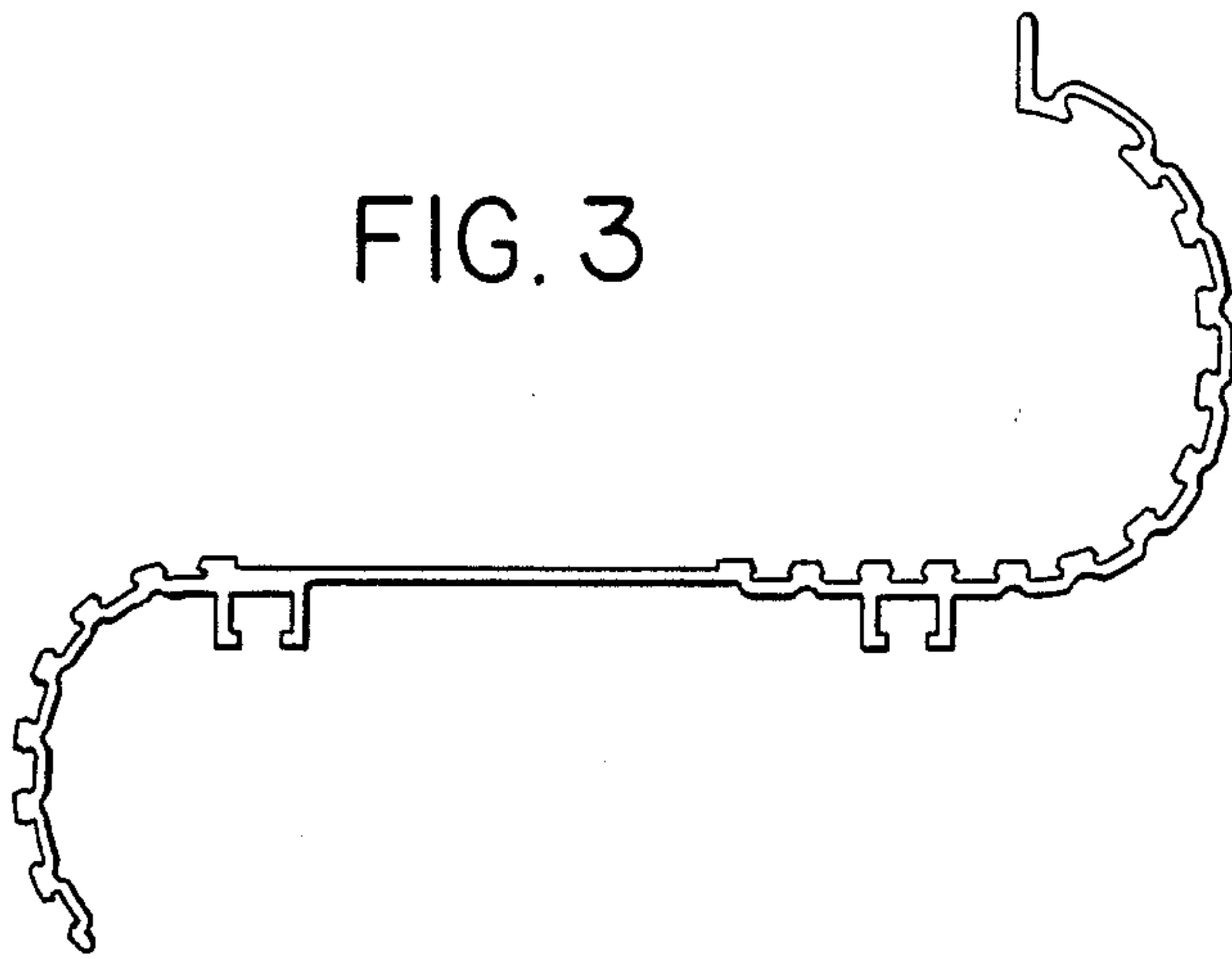

FIG. 2

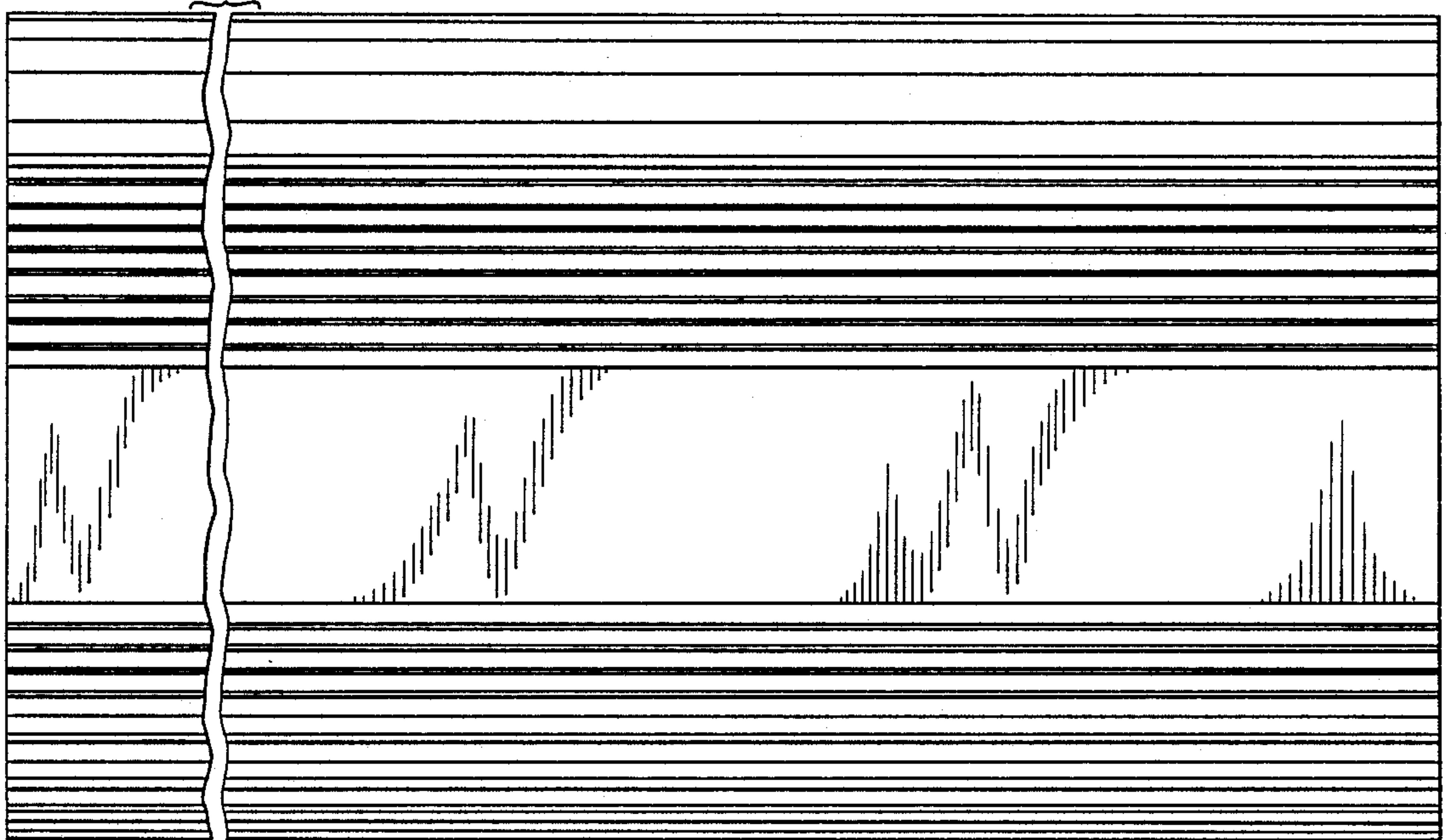
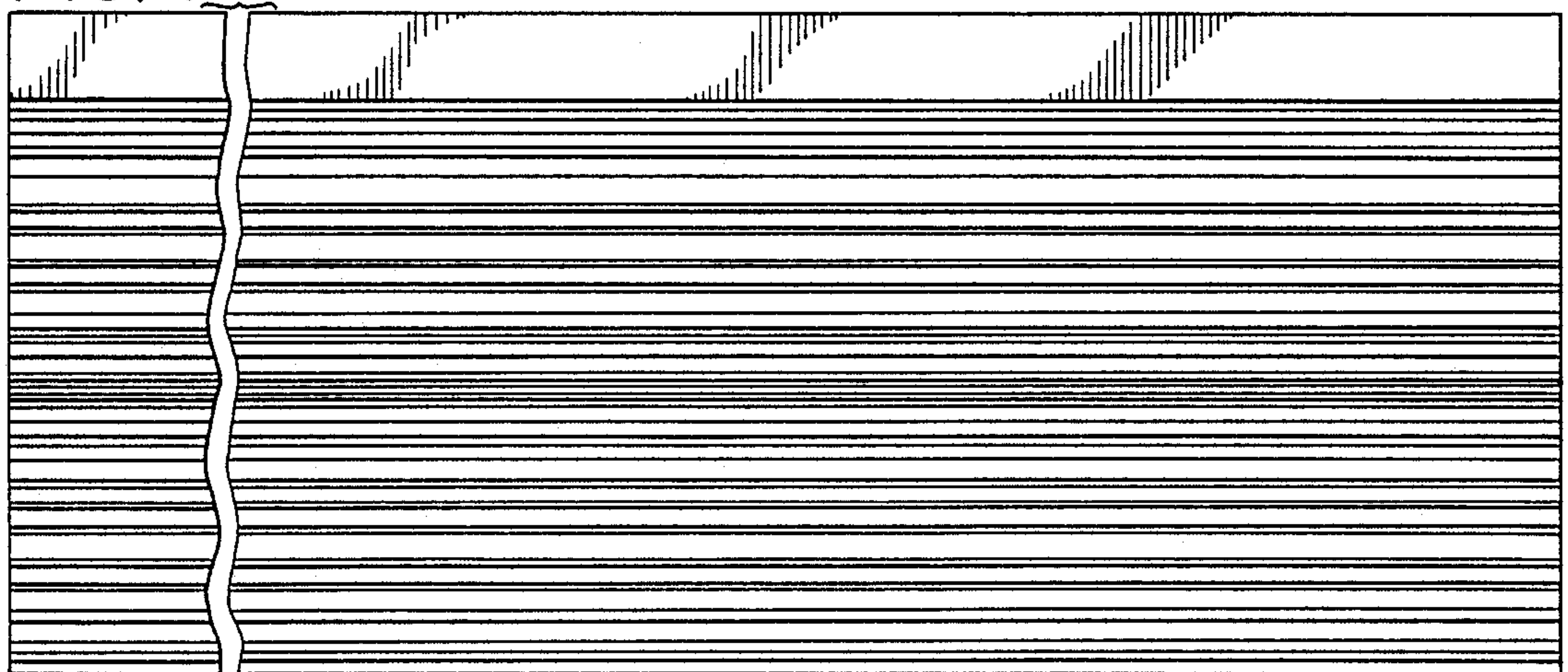

FIG. 4



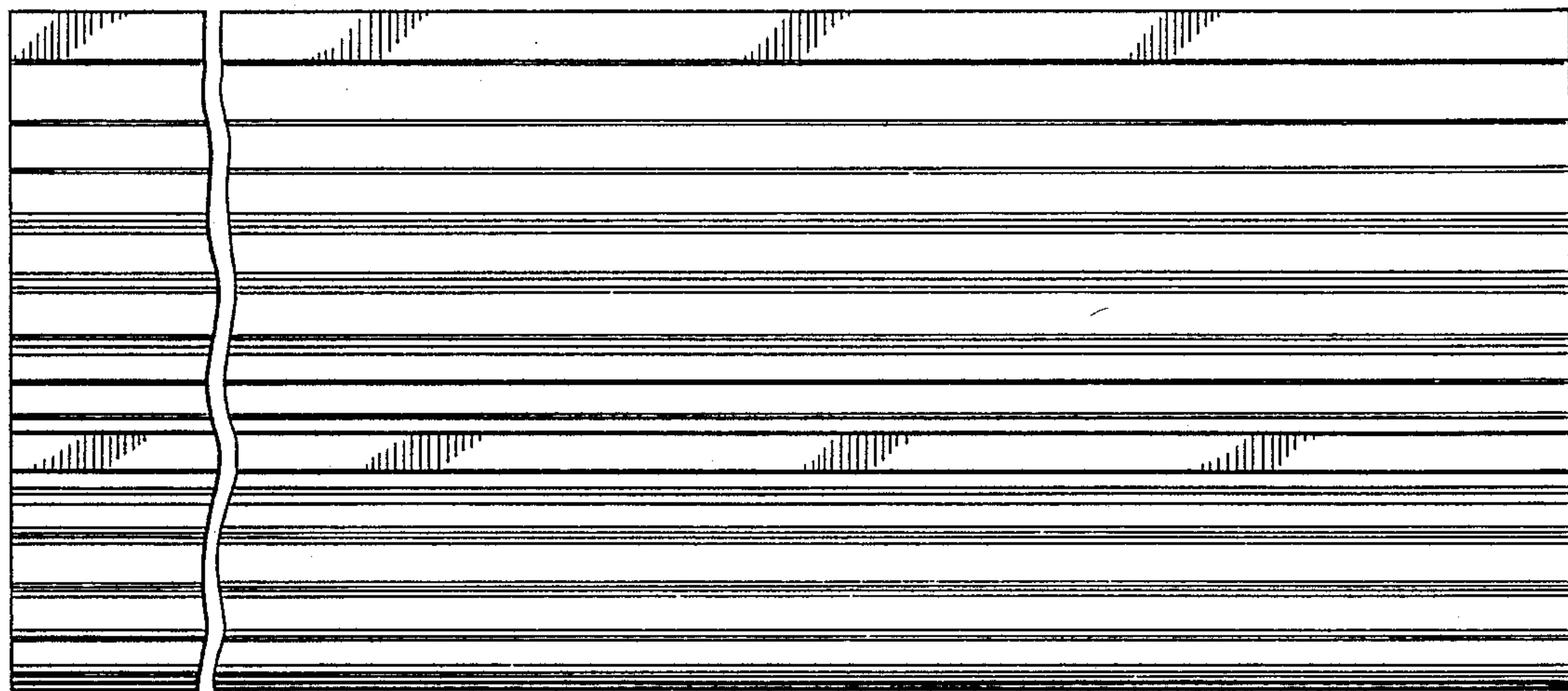

FIG. 5

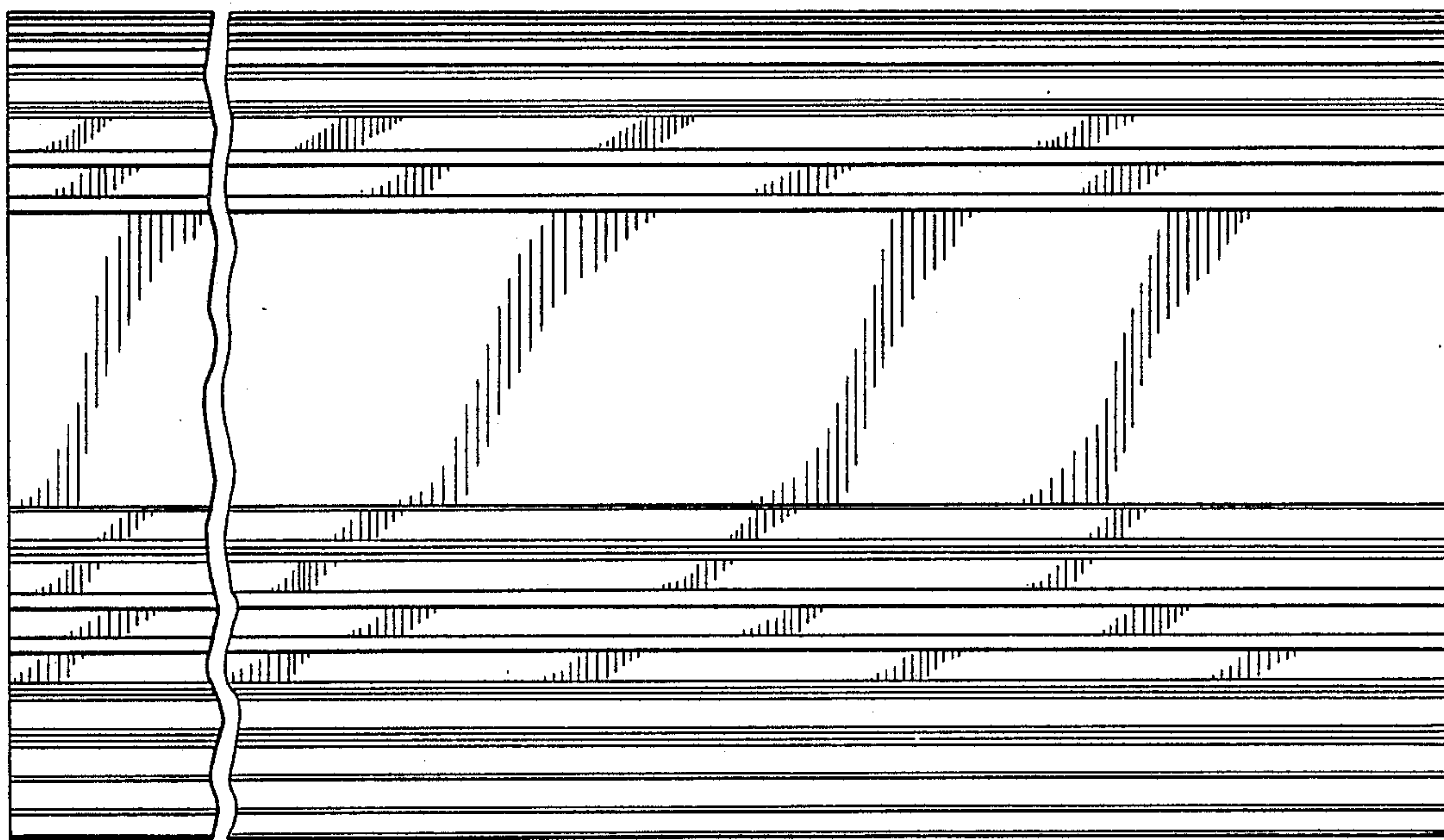

FIG. 6

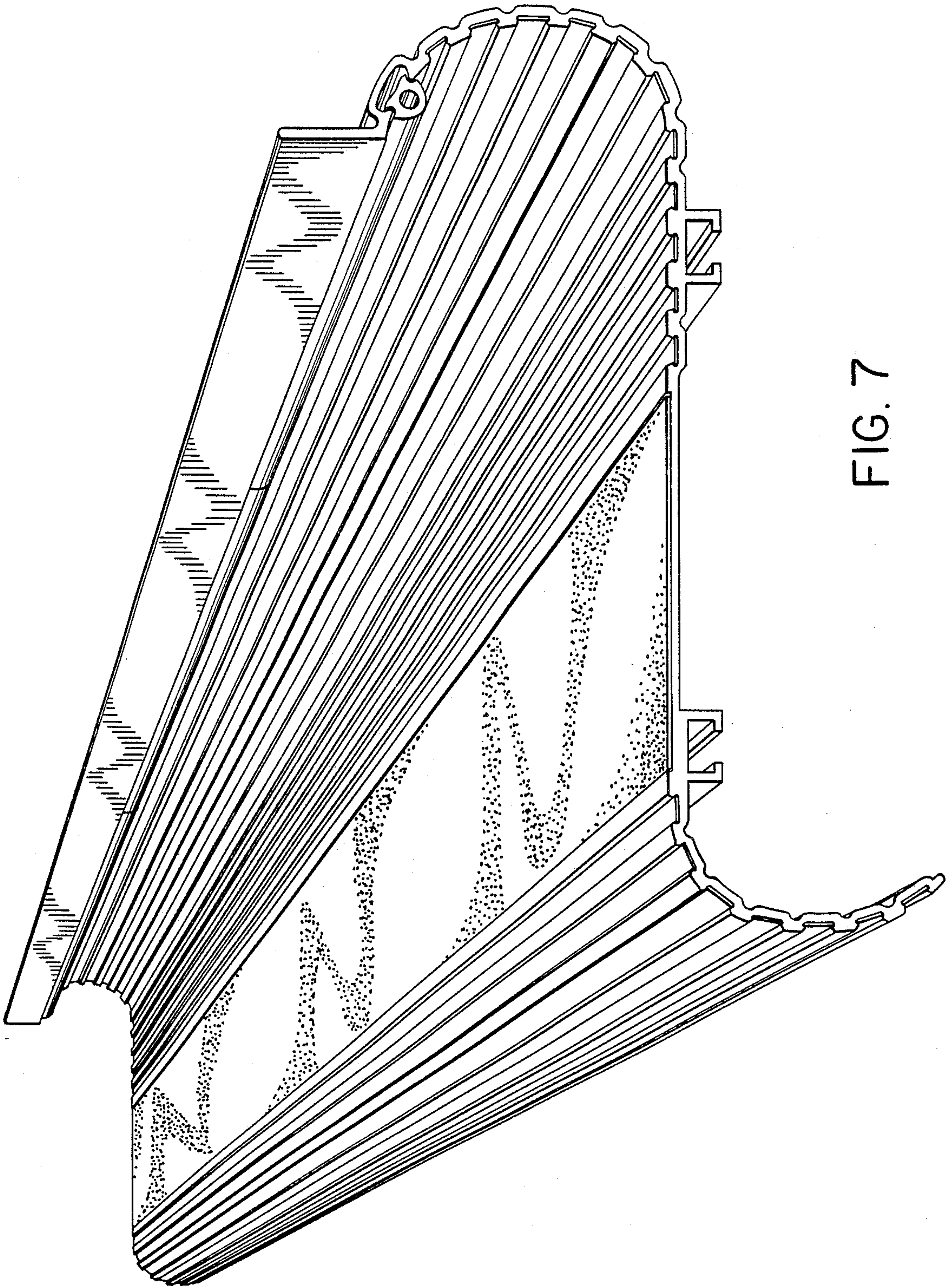

FIG. 7

FIG. 8

