

[54] **FRONT CAP FOR A VAN-TYPE VEHICLE**

[76] **Inventor:** Elton E. Mountz, R.D. #2, Box 199,  
Morgantown, Pa. 19543

[\*\*] **Term:** 14 Years

[21] **Appl. No.:** 76,557

[22] **Filed:** Jul. 22, 1987

[52] **U.S. Cl.** ..... D12/181; D12/96;  
D12/190

[58] **Field of Search** ..... D12/181, 190, 93, 97,  
D12/96; 296/180.1, 180.4, 91, 183

[56] **References Cited**

**U.S. PATENT DOCUMENTS**

D. 290,106	6/1987	Arnold	.....	D12/181
4,309,053	1/1982	Lett	.....	296/91
4,403,804	9/1983	Mountz et al.	.....	296/183
4,457,550	7/1984	Gielow et al.	.....	296/180.4

*Primary Examiner*—James M. Gandy  
*Attorney, Agent, or Firm*—Neil F. Markva

[57] **CLAIM**

The ornamental design for a front cap for a van-type vehicle, as shown and described.

**DESCRIPTION**

FIG. 1 is a perspective view of the front cap for a van-type vehicle showing my new design it being understood that the broken lines are for illustrative purposes only and form no part of the claimed design; FIG. 2 is an enlarged front elevational view thereof; FIG. 3 is a side elevational view as seen from the left in FIG. 2; FIG. 4 is a side elevational view as seen from the right in FIG. 2; FIG. 5 is a top plan view of FIG. 2; FIG. 6 is a bottom plan view of FIG. 2; and FIG. 7 is a rear elevational view of FIG. 2.

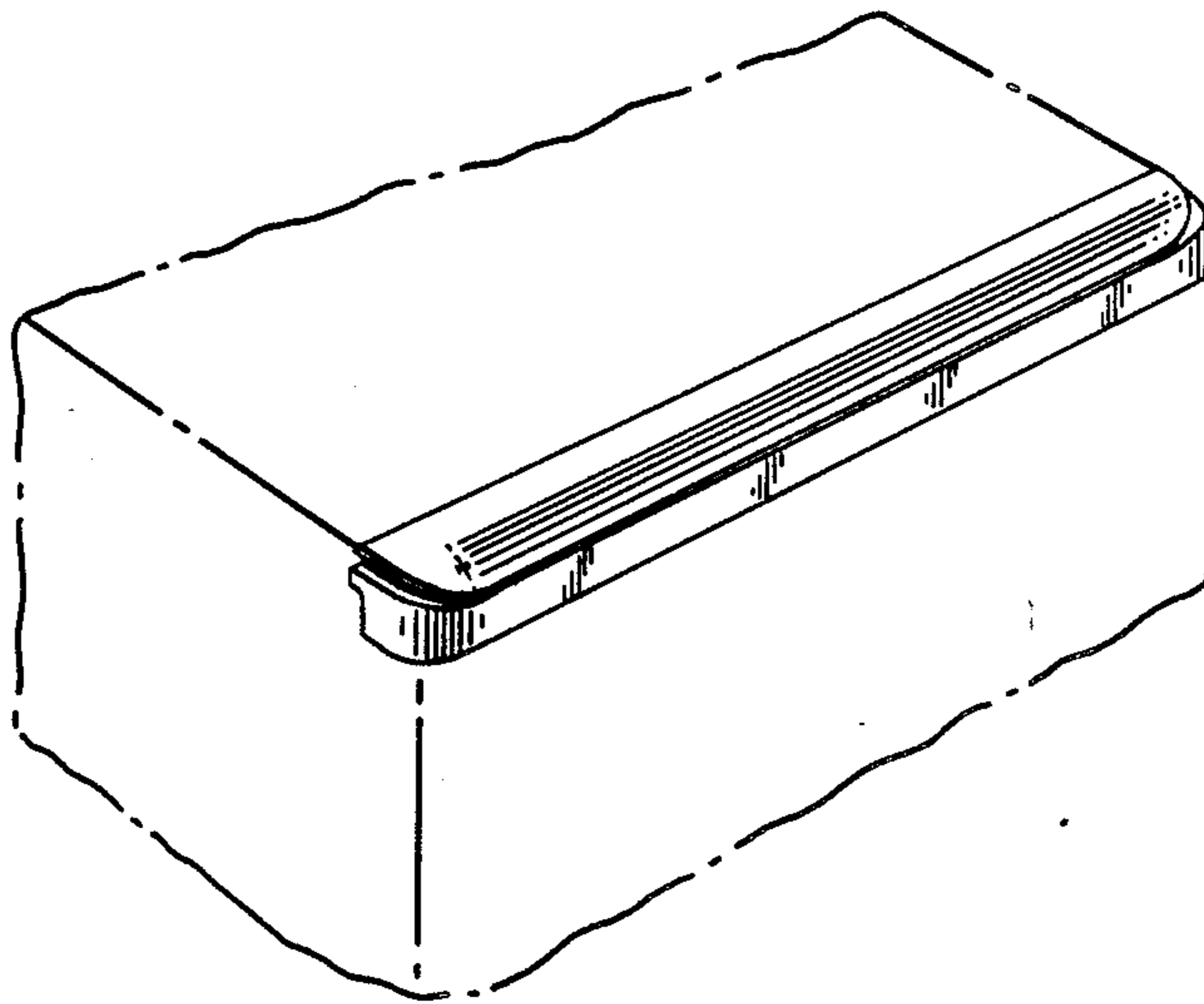

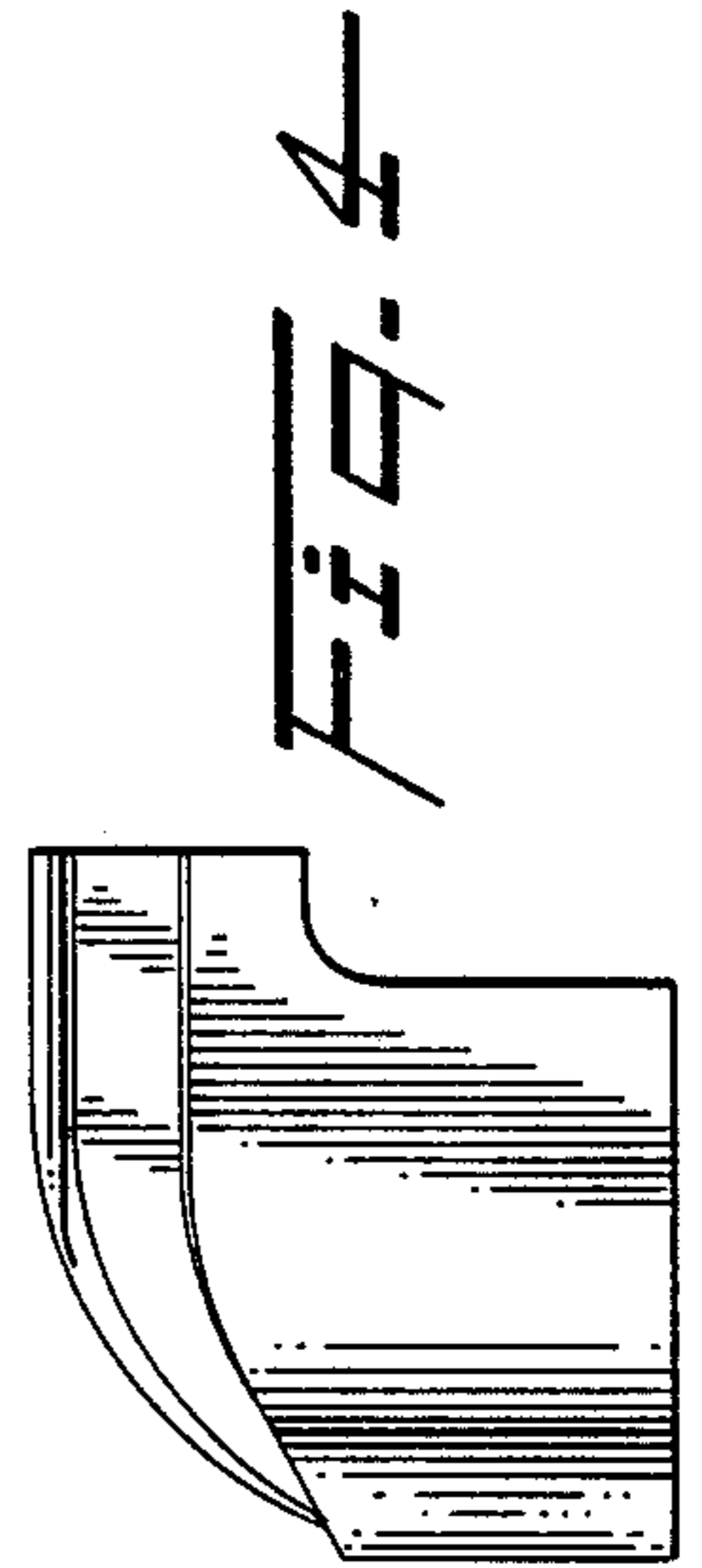
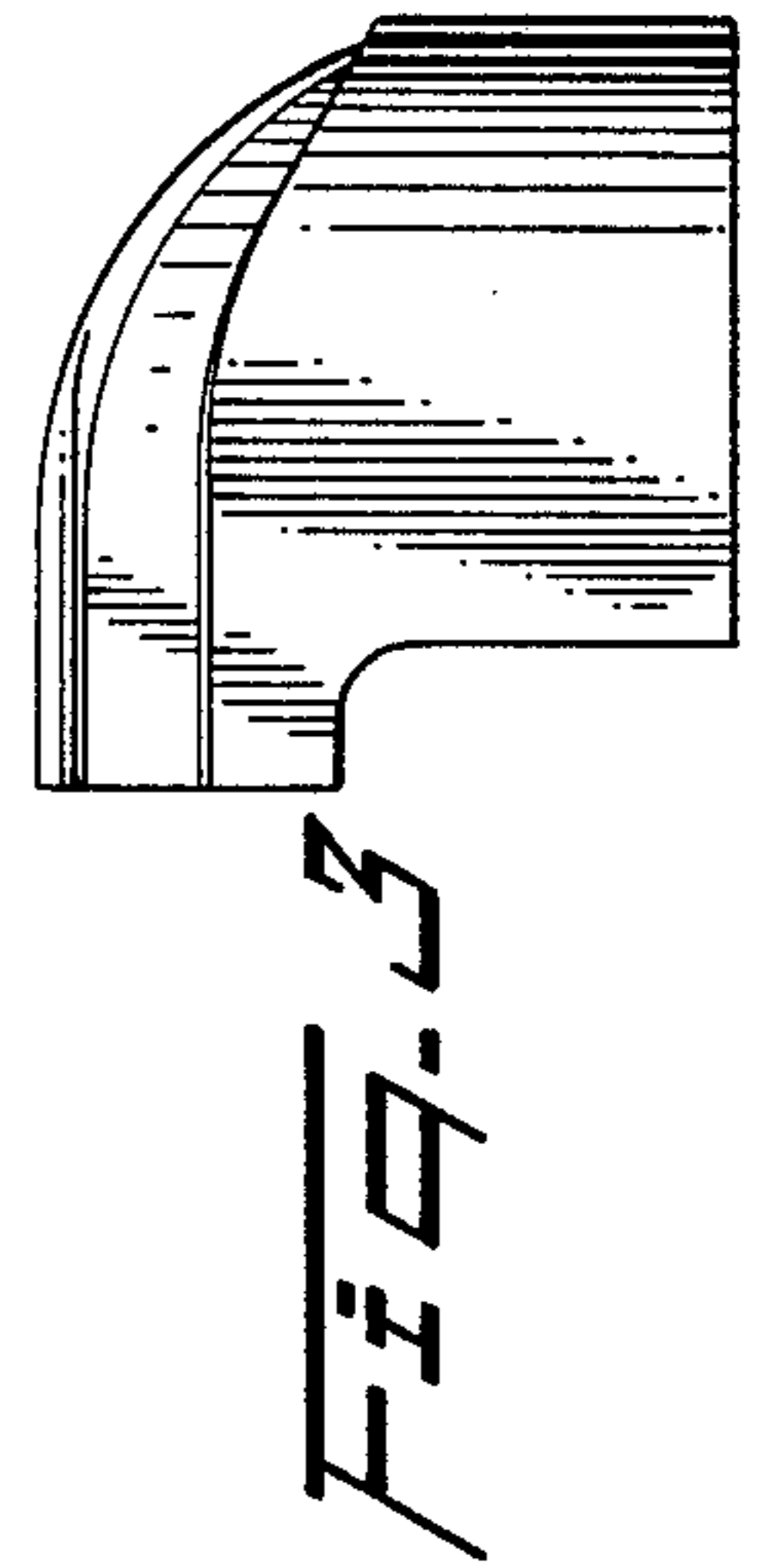
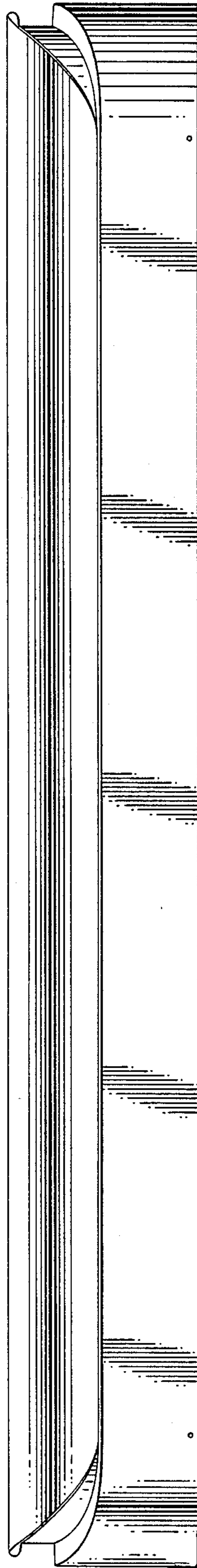
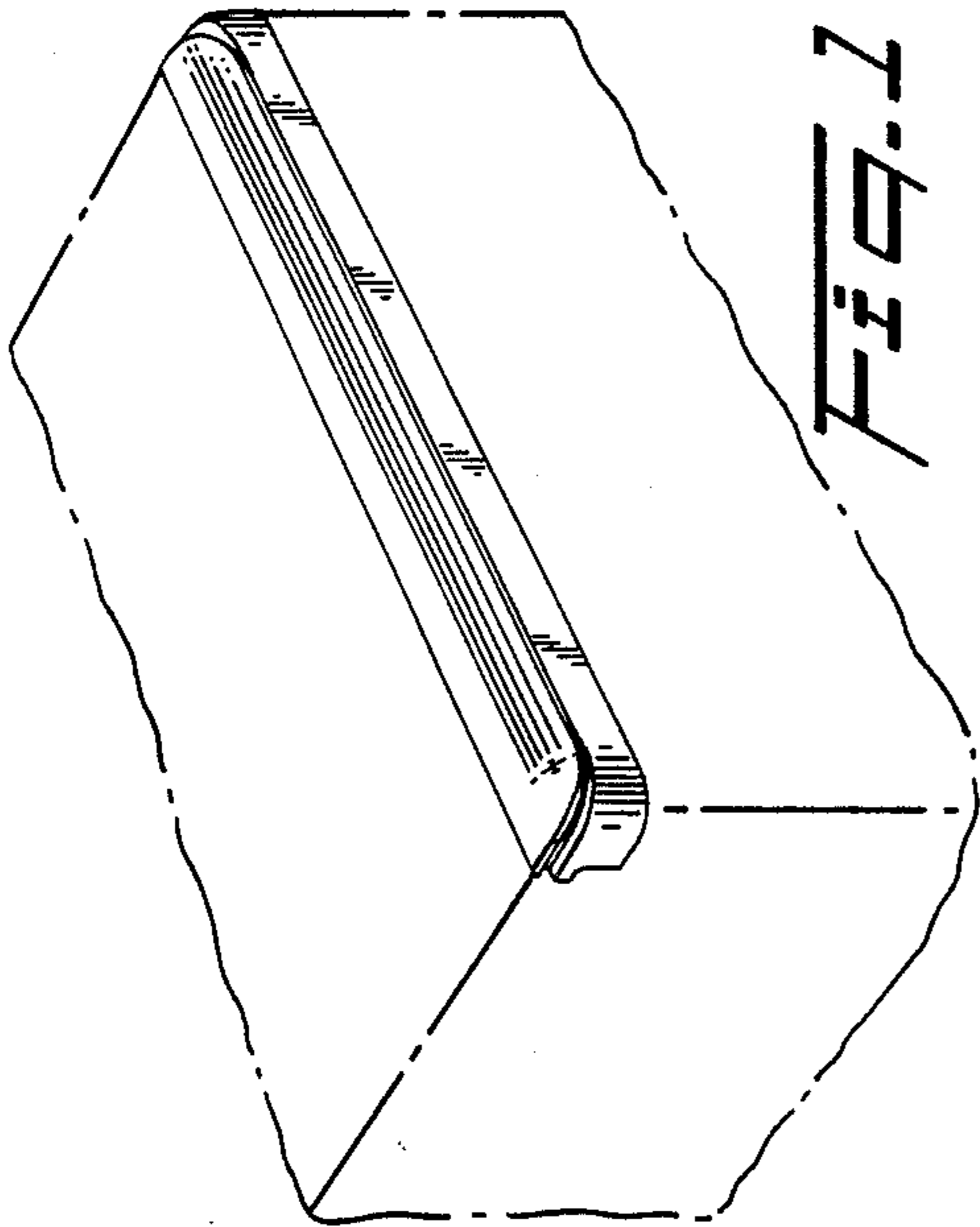

FIG. 5

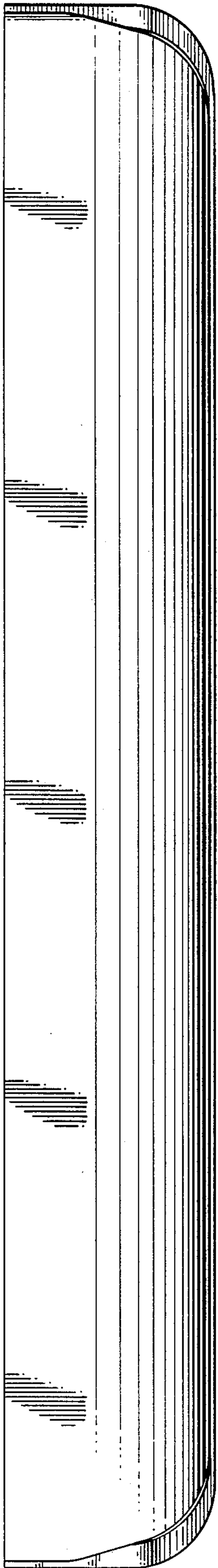

FIG. 6

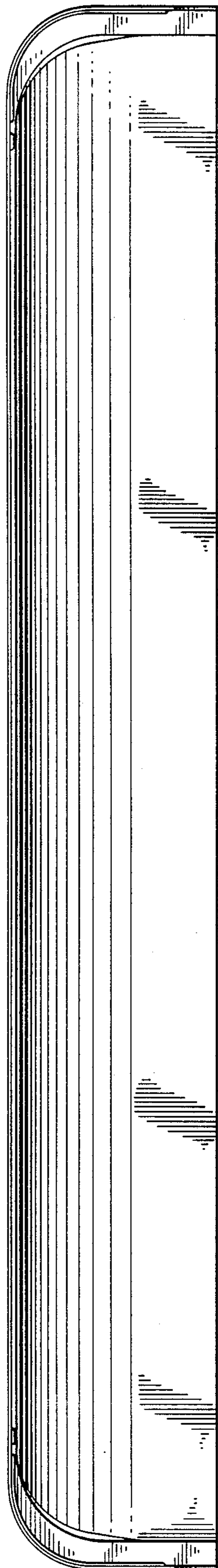

FIG. 7

