

[54] **GUITAR BODY**

[75] **Inventors:** Stephen T. Ridinger, Irvine; Russell E. Orr, II, El Toro, both of Calif.

[73] **Assignee:** Evets Corporation, Irvine, Calif.

[**] **Term:** 14 Years

[21] **Appl. No.:** 57,866

[22] **Filed:** Jun. 4, 1987

[52] **U.S. Cl.** D17/20

[58] **Field of Search** D17/14, 18, 19, 20;
84/1.16, 267, 291, 293

[56] **References Cited**

U.S. PATENT DOCUMENTS

| | | | | |
|------------|--------|------------|-------|--------|
| D. 296,704 | 7/1988 | Coins | | D17/18 |
| D. 297,146 | 8/1988 | Petschulat | | D17/20 |
| 3,439,570 | 4/1969 | Lee | | 84/293 |

FOREIGN PATENT DOCUMENTS

141585 5/1980 German Democratic Rep. ... 84/291

Primary Examiner—Bernard Ansher
Assistant Examiner—Adir Aronovich
Attorney, Agent, or Firm—Gordon L. Peterson

[57] **CLAIM**

The ornamental design for a guitar body, substantially as shown.

DESCRIPTION

FIG. 1 is an isometric view of a guitar body embodying our new design.

FIG. 2 is a top plan view thereof.

FIG. 3 is a side elevational view.

FIG. 4 is an end elevational view taken from the right end of FIG. 2.

FIG. 5 is a side elevational view showing the other side of the guitar body.

FIG. 6 is an end elevational view taken from the left end of FIG. 2.

FIG. 7 is a bottom plan view.

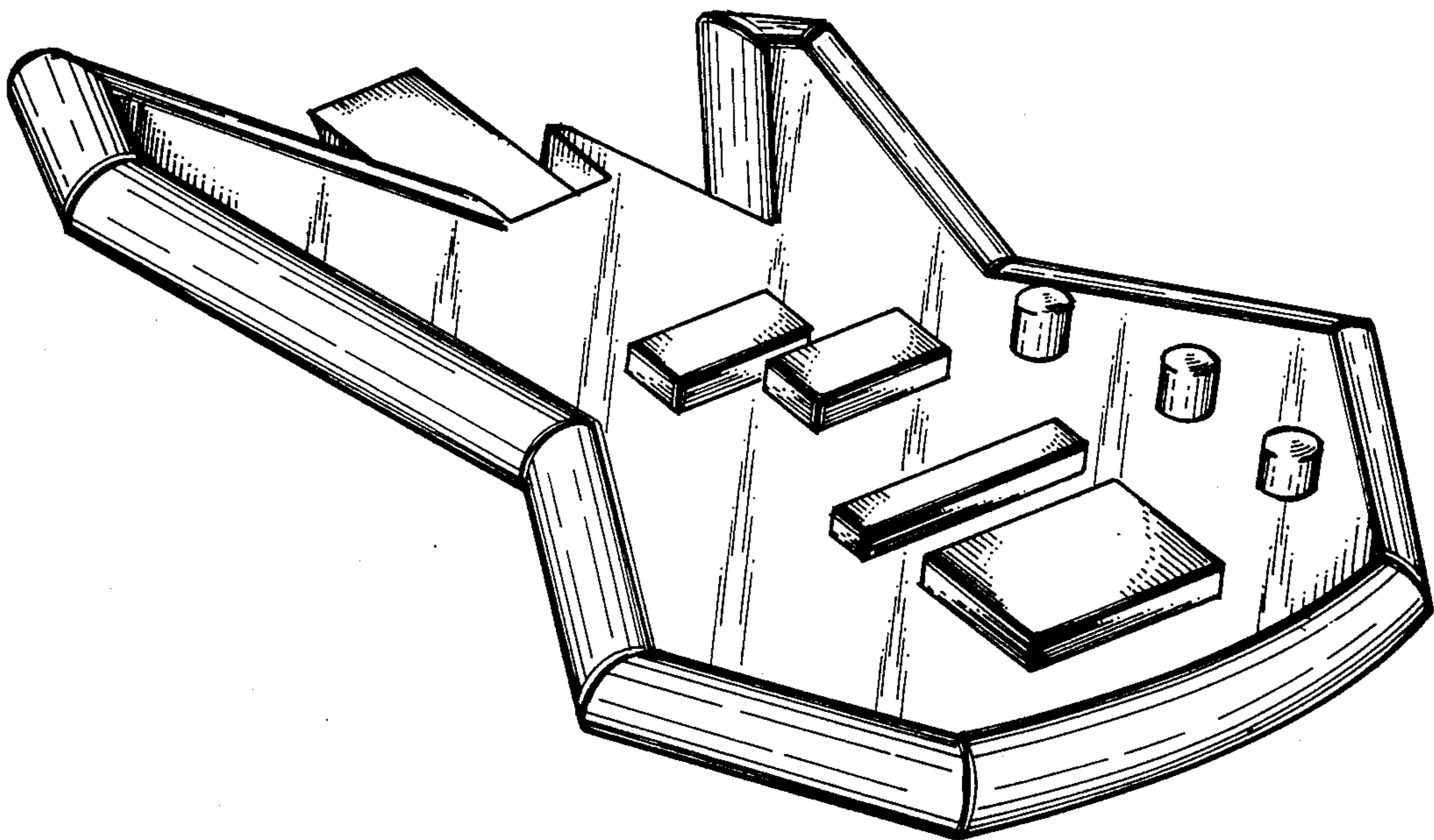

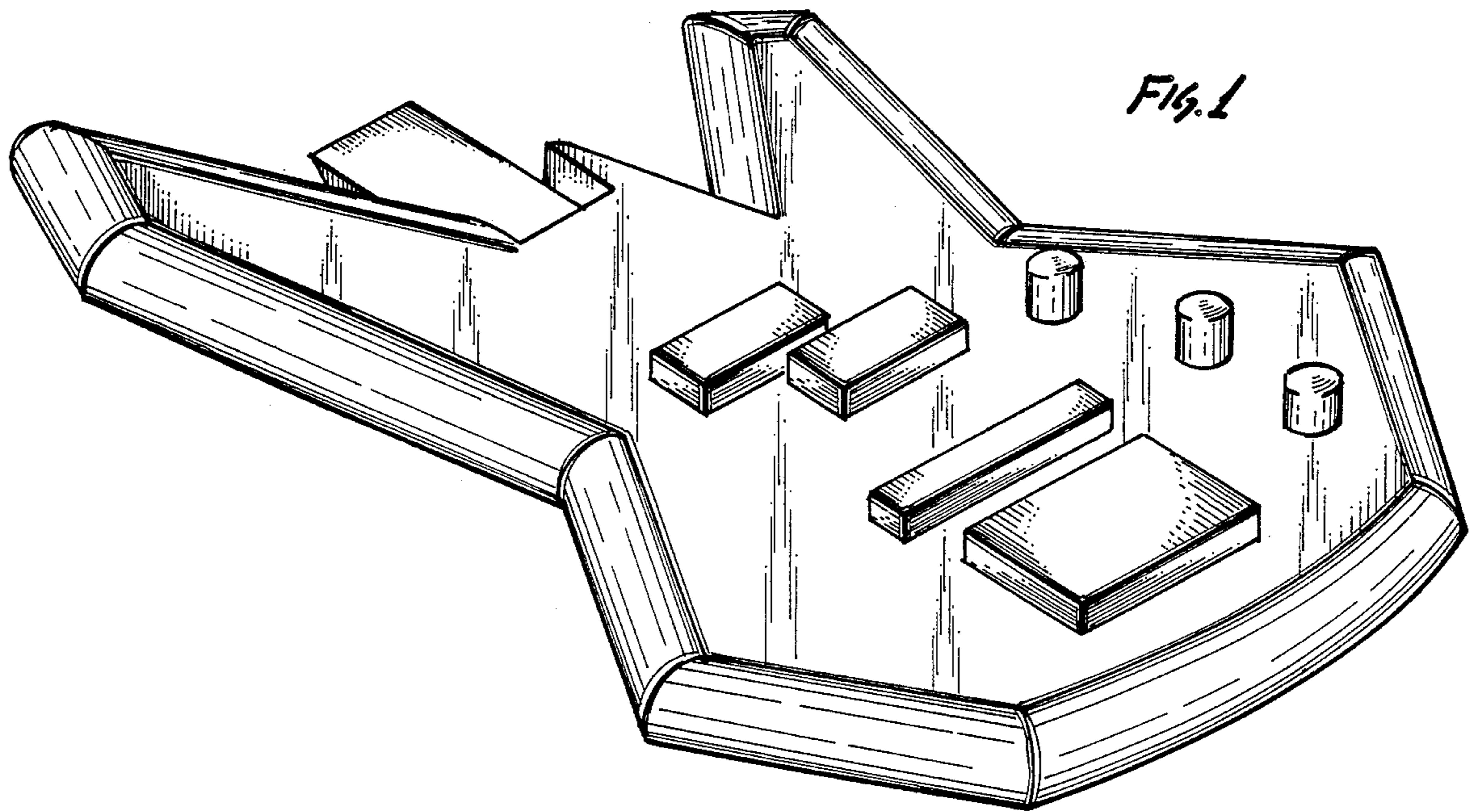

Fig. 6

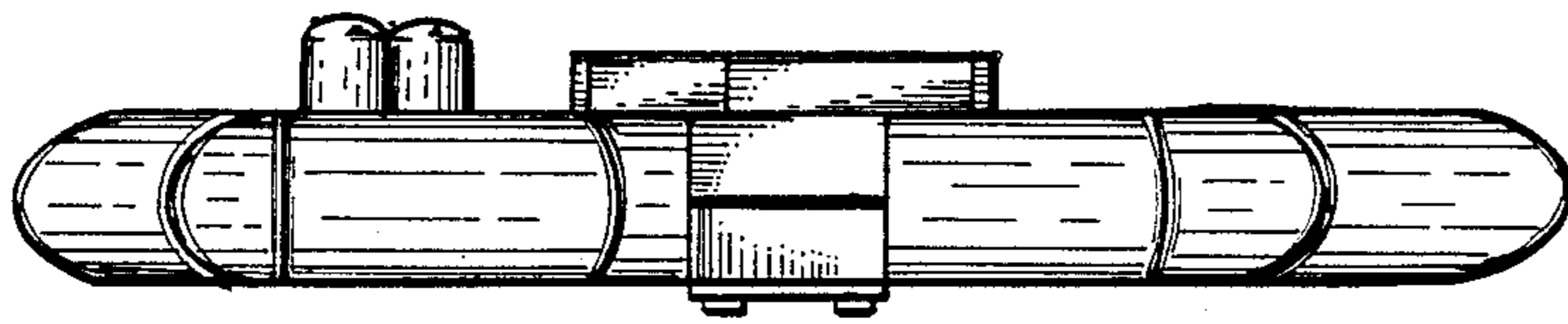
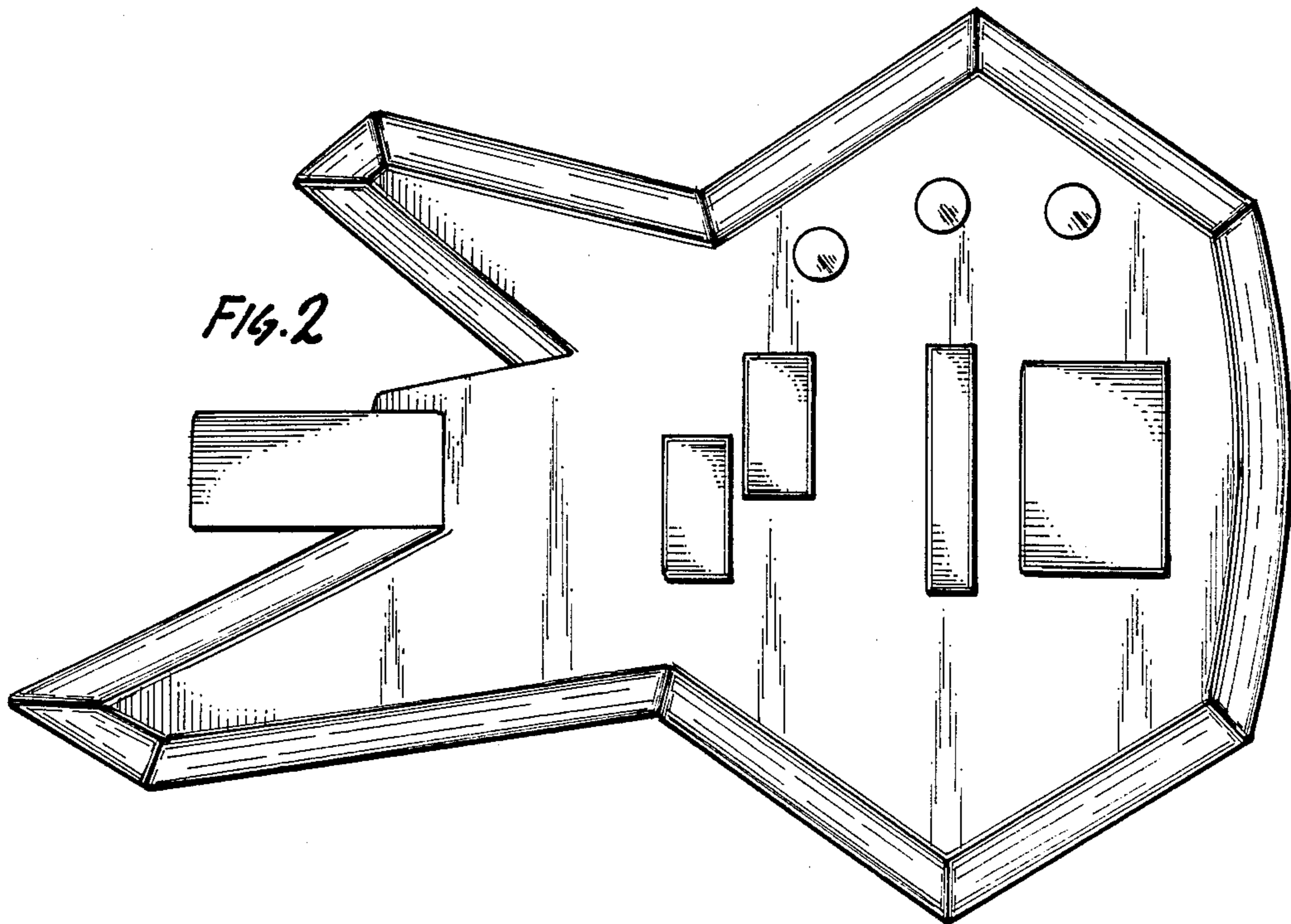

Fig. 2



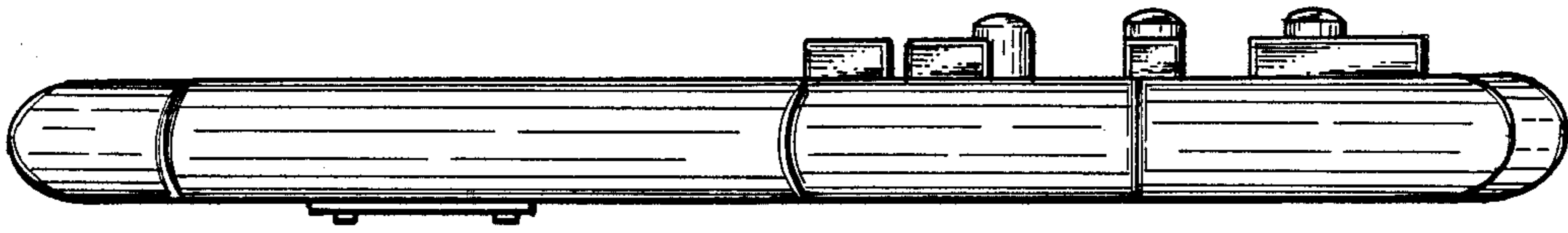

Fig. 3

Fig. 4

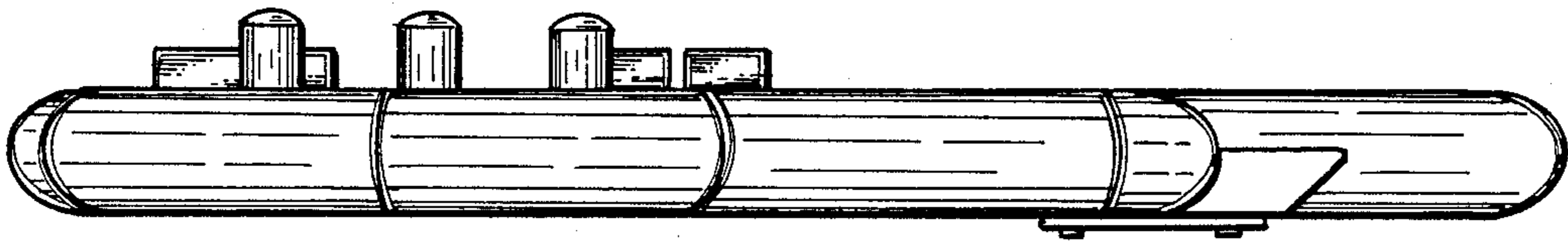
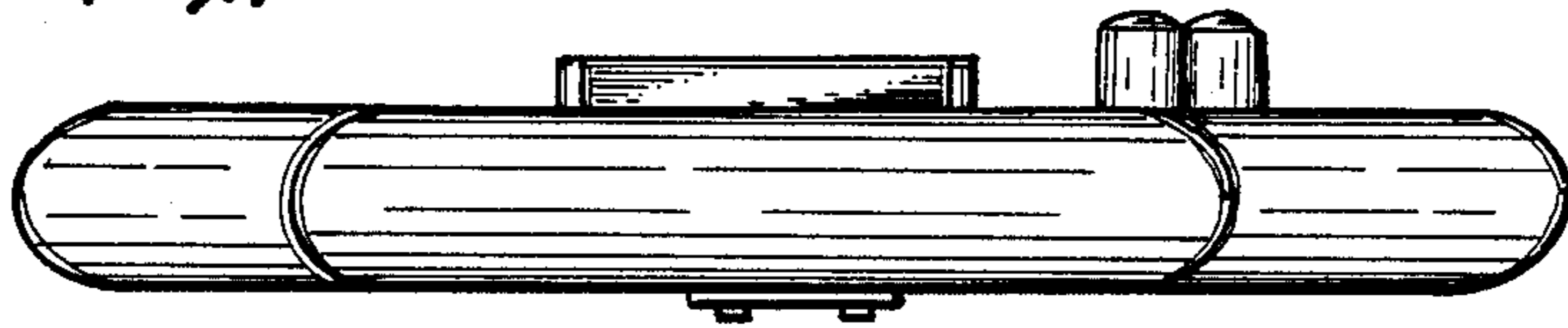

Fig. 5

Fig. 7

