

[54] **BATTERY**

[75] **Inventors:** Larry K. W. Ching, Jr., Littleton;  
Neil Puester, Aurora, both of Colo.

[73] **Assignee:** Gates Energy Products, Inc.,  
Gainesville, Fla.

[\*\*] **Term:** 14 Years

[21] **Appl. No.:** 193,691

[22] **Filed:** May 13, 1988

[52] **U.S. Cl. ....** D13/8

[58] **Field of Search ....** D13/4, 8-11;  
D14/137; 429/27, 54, 97-100, 123, 133, 149,  
151, 153, 159, 160, 163, 176; 307/150; 320/2

[56] **References Cited**

**U.S. PATENT DOCUMENTS**

912,705	2/1909	Mason	429/100 X
4,227,140	10/1980	Nardella et al.	320/2
4,383,011	5/1983	McClelland	429/54
4,407,911	10/1983	Hooke	429/99 X
4,510,215	4/1985	Adam	D13/4 X
4,554,221	11/1985	Schmid	429/99 X
4,592,927	6/1986	Juergens et al.	429/160
4,780,379	10/1988	Puester	429/160 X

**FOREIGN PATENT DOCUMENTS**

775416	5/1957	Australia	429/159
663911	5/1965	Belgium	429/159

**OTHER PUBLICATIONS**

"The Perfect Balance of Power from Gates", 1986  
Gates Corp. brochure.  
Gates Monobloc Battery brochure, 3-85.  
Gates Rechargeable Cells brochure, 3-85.

*Primary Examiner*—James M. Gandy  
*Assistant Examiner*—Joel Sincavage  
*Attorney, Agent, or Firm*—J. E. Ebel; C. H. Castleman,  
Jr.; H. W. Oberg, Jr.

[57] **CLAIM**

The ornamental design for a battery, as shown and described.

**DESCRIPTION**

FIG. 1 is a top perspective view of a battery showing our new design;  
FIG. 2 is a bottom plan view thereof;  
FIG. 3 is a top plan view thereof;  
FIG. 4 is a front elevational view thereof, the rear elevational view being a mirror image;  
FIG. 5 is an end elevational view thereof, the opposite end view being a mirror image.

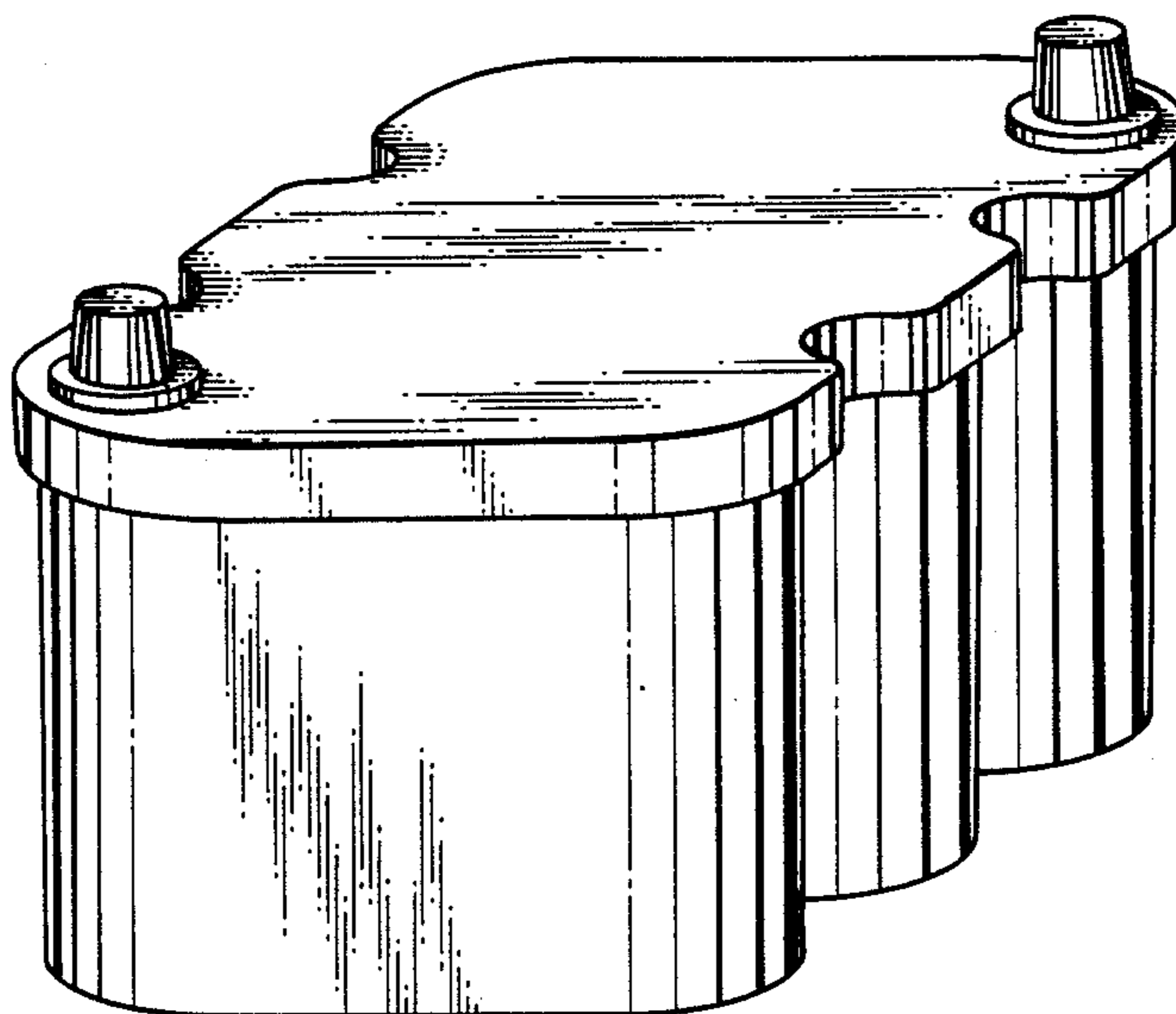

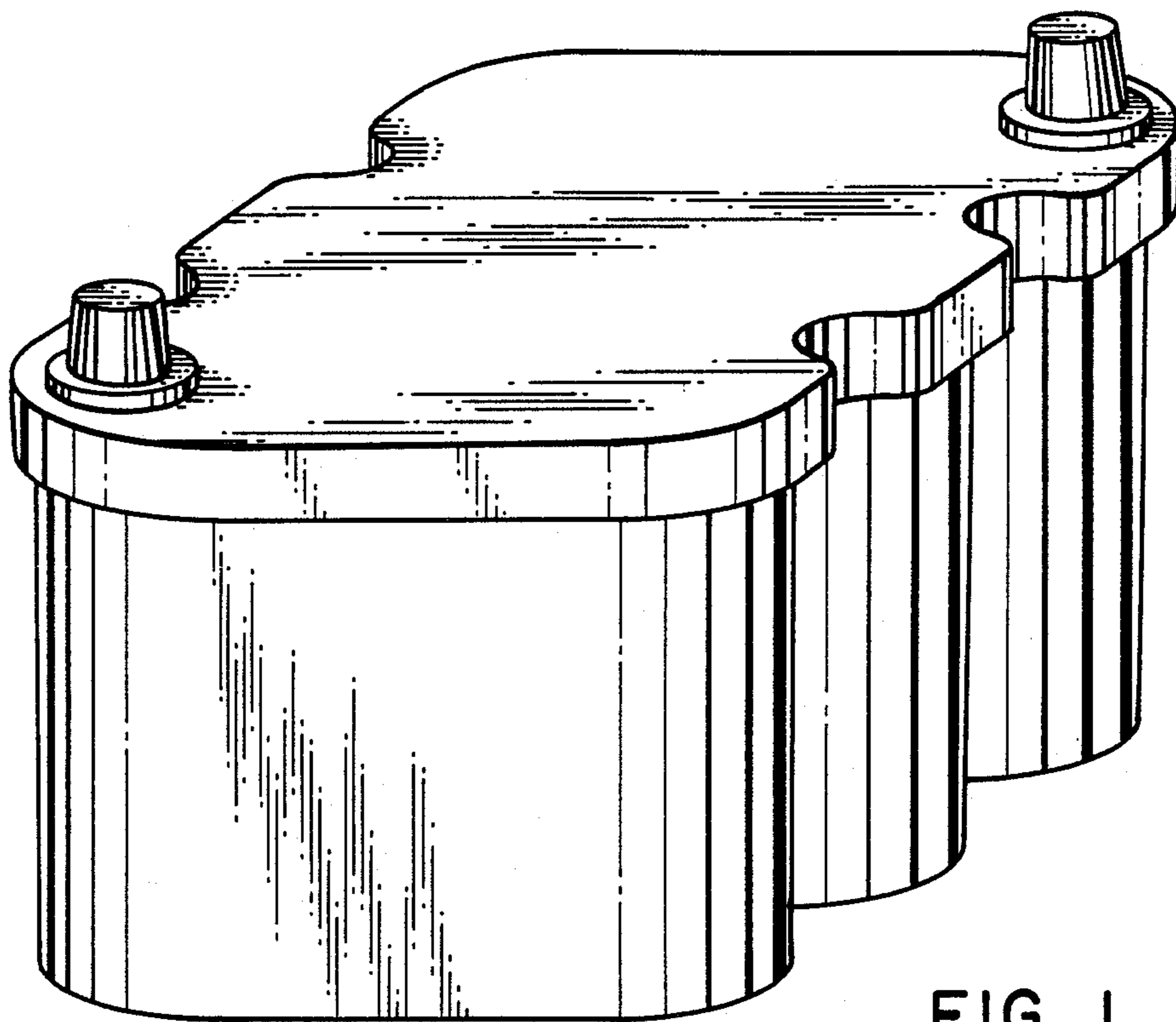

FIG. 1

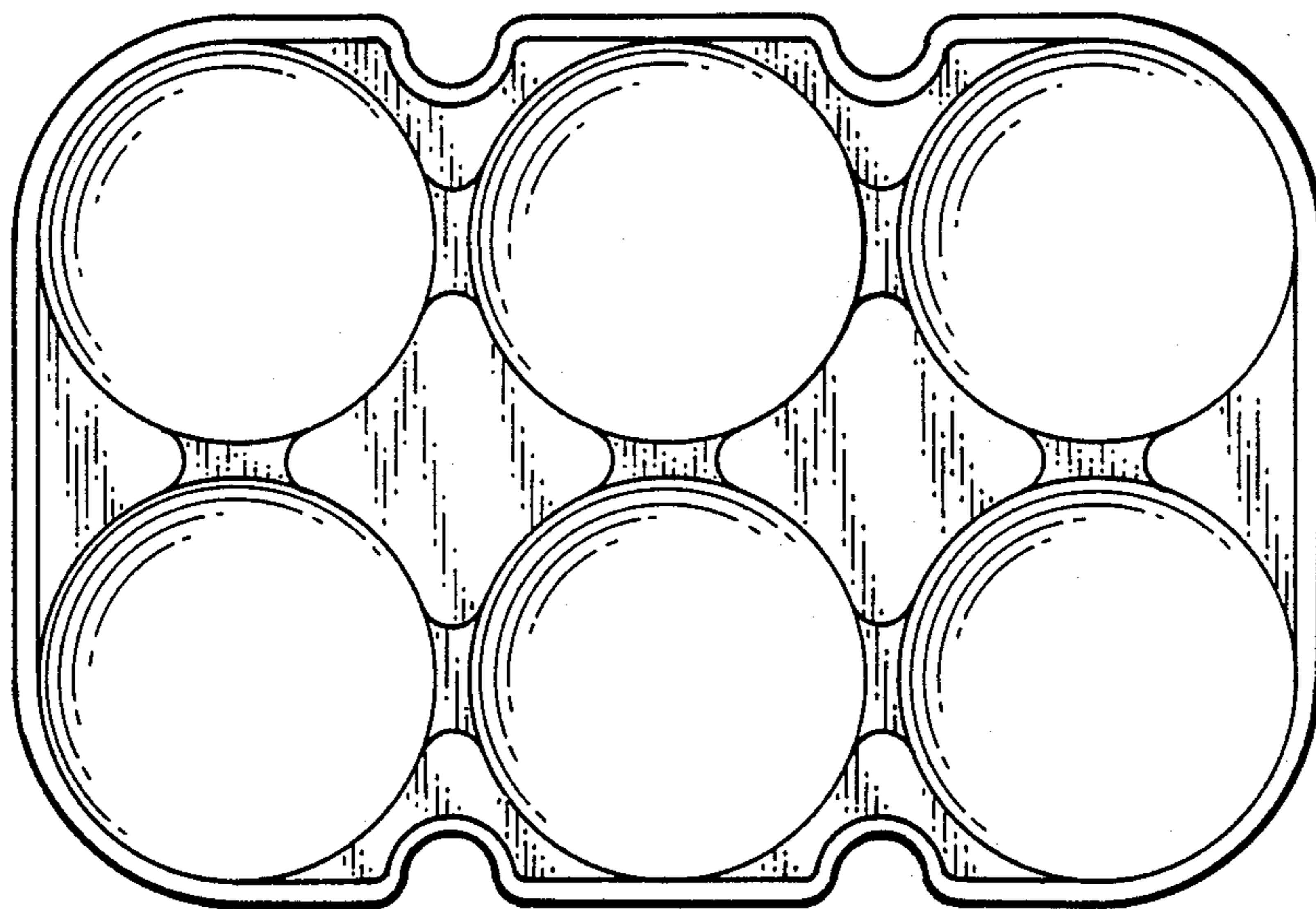

FIG. 2

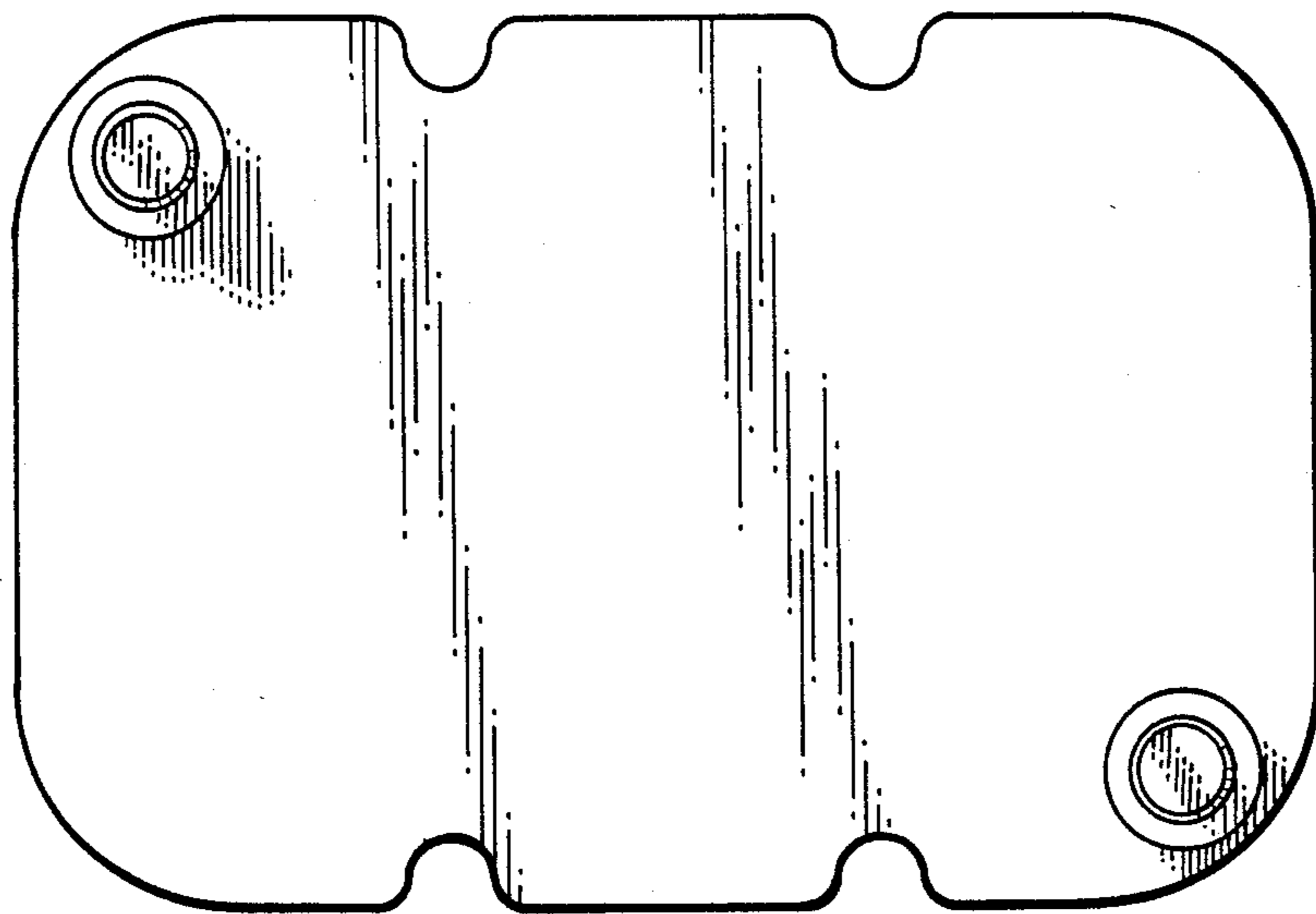

FIG. 3

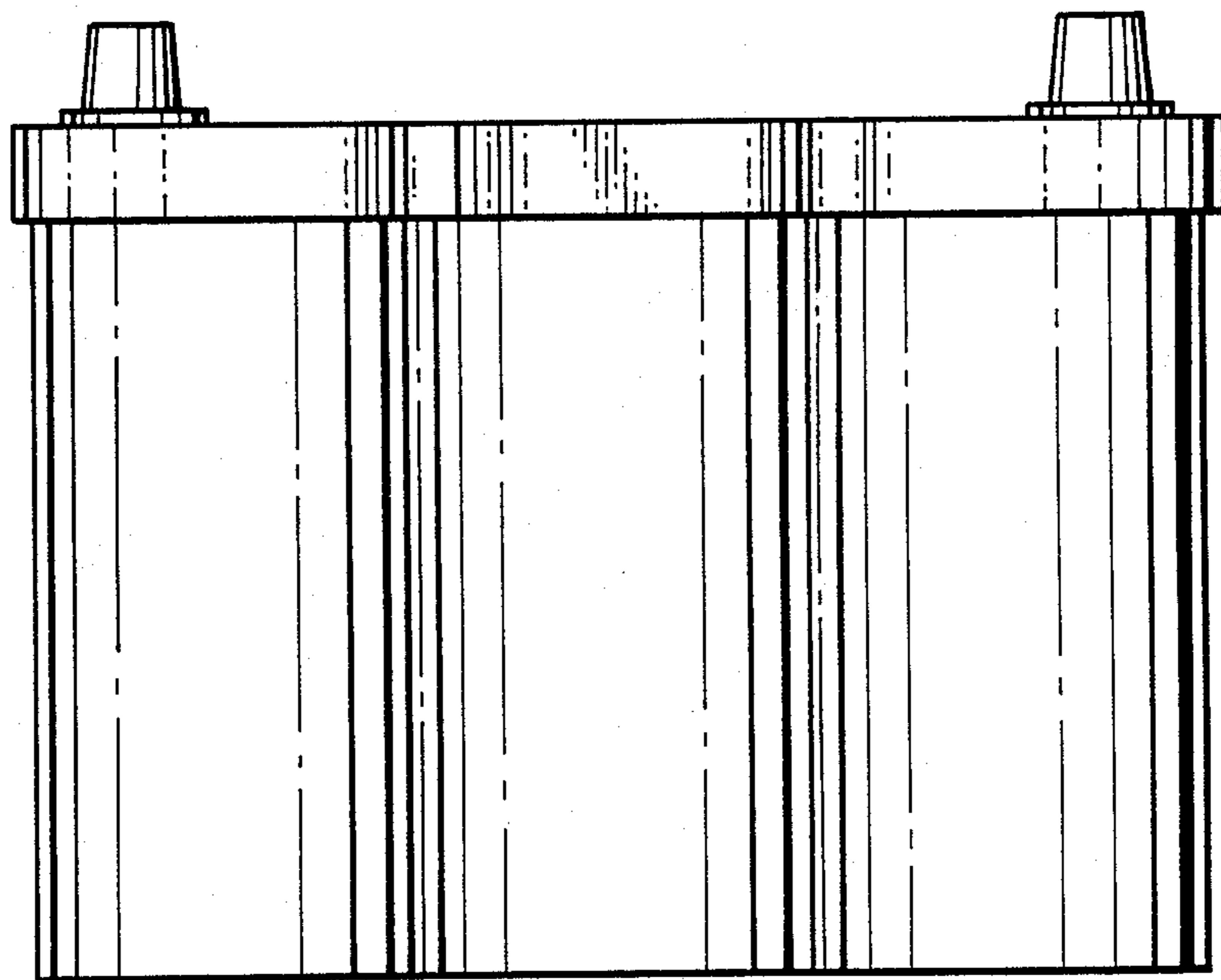

FIG. 4

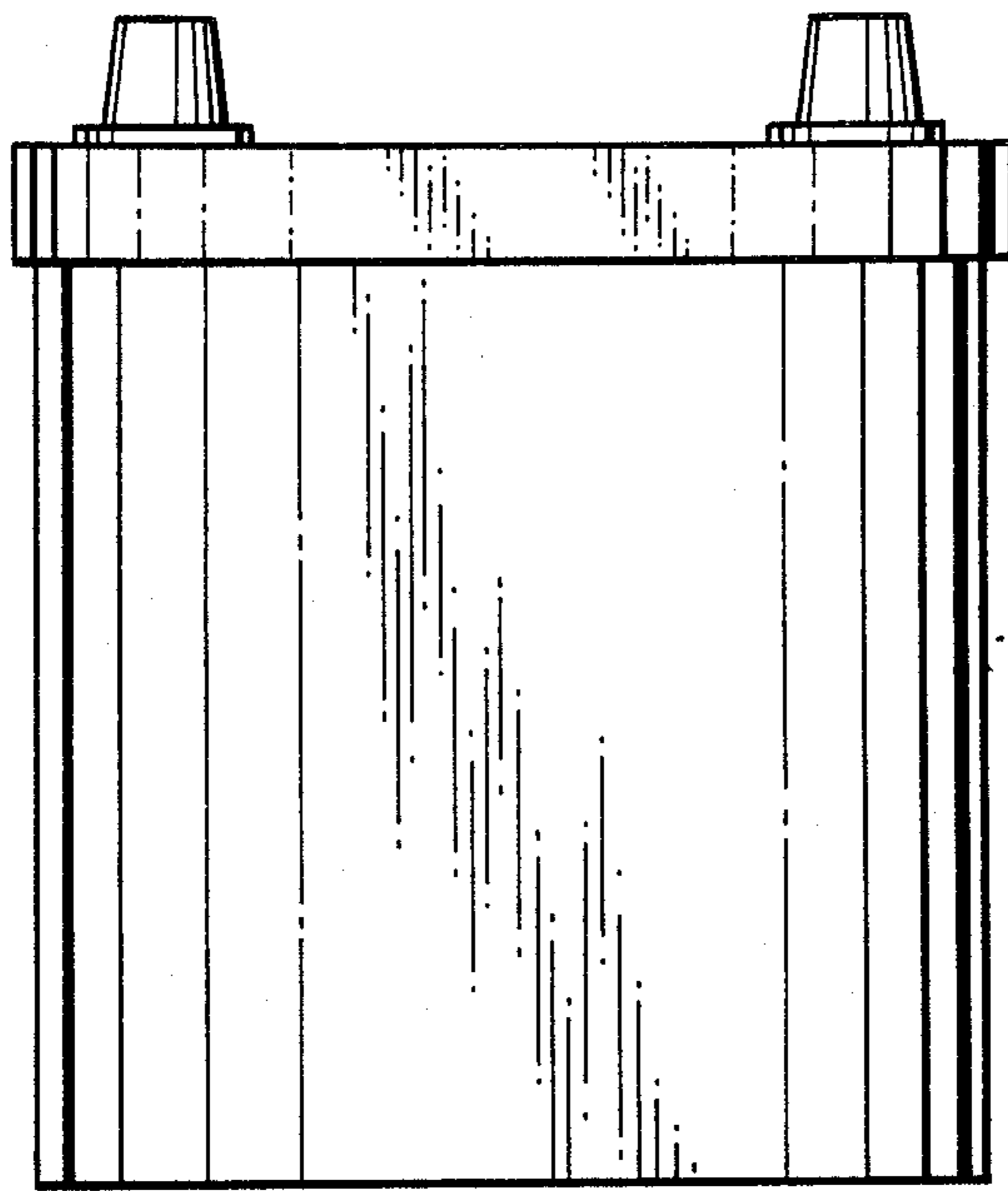

FIG. 5