

[54] BATTERY PACK

[75] Inventors: Fusao Fushiya; Michio Okumura; Yoshiyuki Kubota, all of Anjo, Japan

[73] Assignee: Makita Electric Works, Ltd., Anjo, Japan

[**] Term: 14 Years

[21] Appl. No.: 285,229

[22] Filed: Dec. 16, 1988

[30] Foreign Application Priority Data

Jul. 9, 1988 [JP] Japan 63-27440

[52] U.S. Cl. D13/8

[58] Field of Search D13/4, 8, 9-11; D14/137; D8/61, 68; 429/27, 54, 97-100, 123, 133, 149, 151, 153, 159, 160, 163, 176; 307/150; 320/2

[56] References Cited

U.S. PATENT DOCUMENTS

- D. 295,141 4/1988 Hoshino et al. D8/68
- D. 295,714 5/1988 Sasaki et al. D8/68
- D. 296,072 6/1988 Mochida D8/68

- D. 296,655 7/1988 Yonezawa et al. D8/68
- 3,186,878 6/1965 Filander 429/97
- 4,151,872 5/1985 Okano 429/99 X
- 4,751,452 6/1988 Kilmer et al. 429/99 X

OTHER PUBLICATIONS

Black & Decker Cordless Drill Ad.
Stanley Cordless tool system brochure ©1987.

Primary Examiner—Susan J. Lucas
Assistant Examiner—Joel Sincavage
Attorney, Agent, or Firm—Dennison, Meserole, Pollack & Scheiner

[57] CLAIM

The ornamental design for a battery pack, as shown.

DESCRIPTION

FIG. 1 is a perspective view of a battery pack showing our new design;
FIG. 2 is a front elevational view thereof;
FIG. 3 is a rear elevational view thereof;
FIG. 4 is a left side elevational view thereof;
FIG. 5 is a right side elevational view thereof;
FIG. 6 is a top plan view thereof; and
FIG. 7 is a bottom plan view thereof.

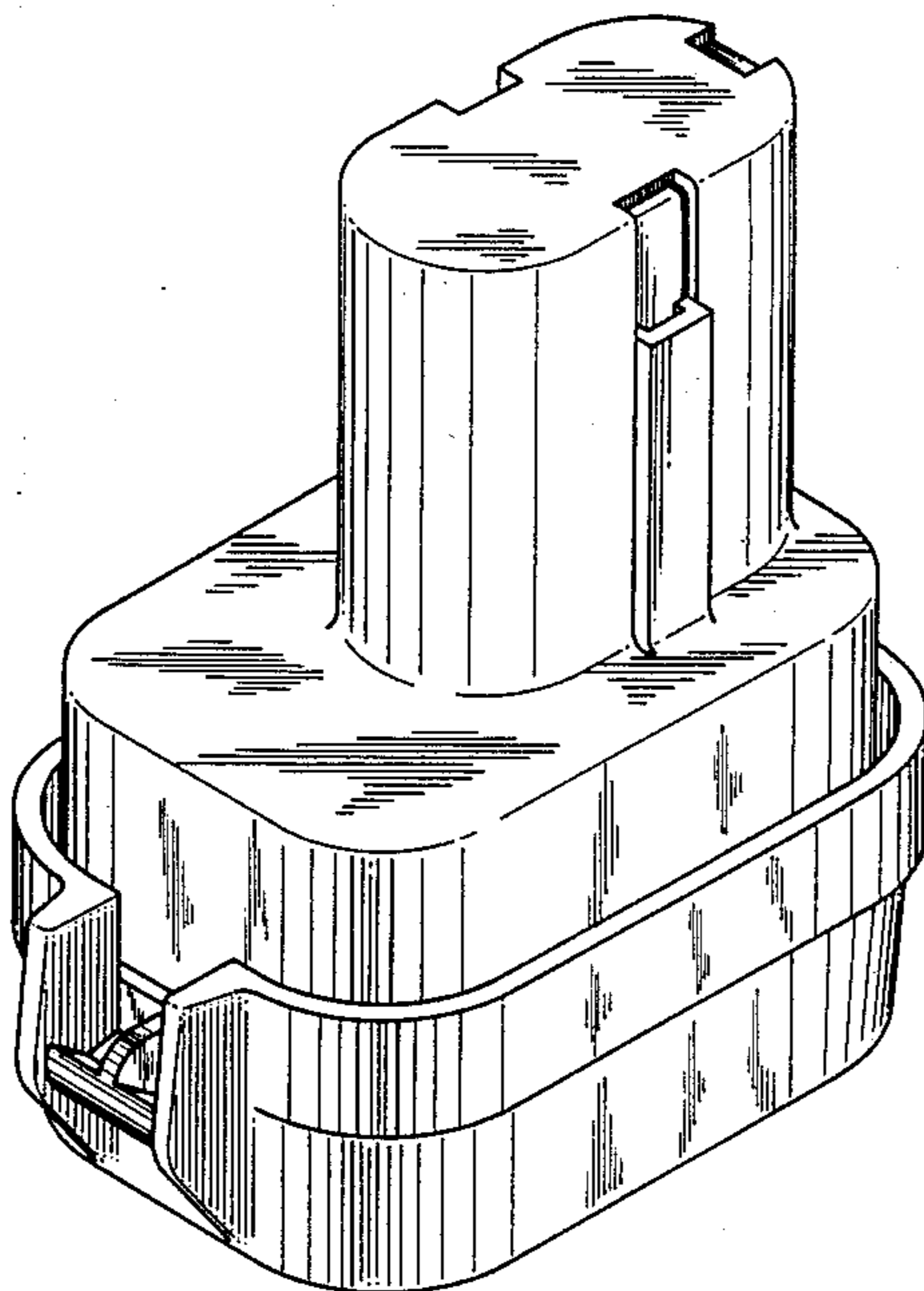

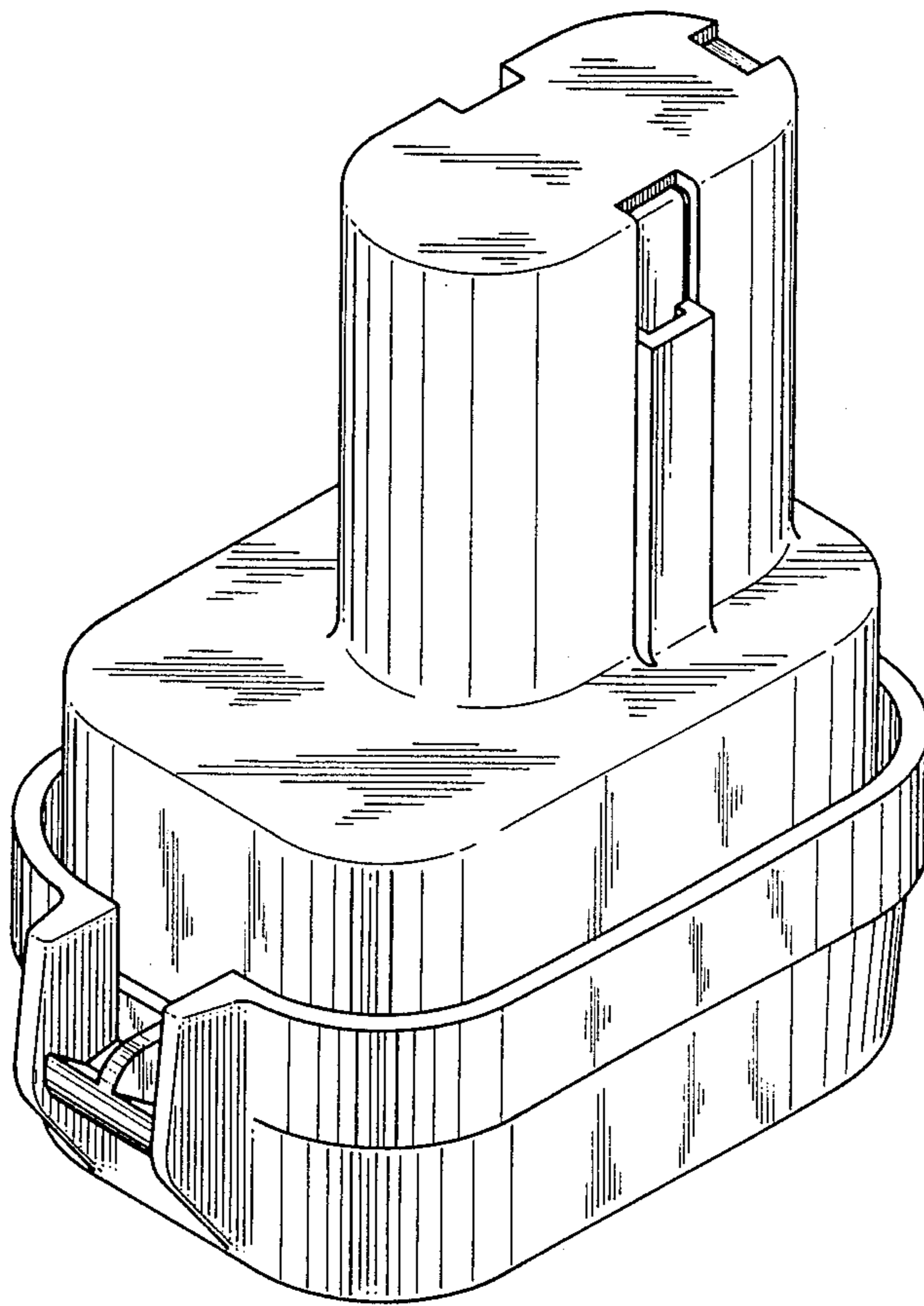

FIG. 1

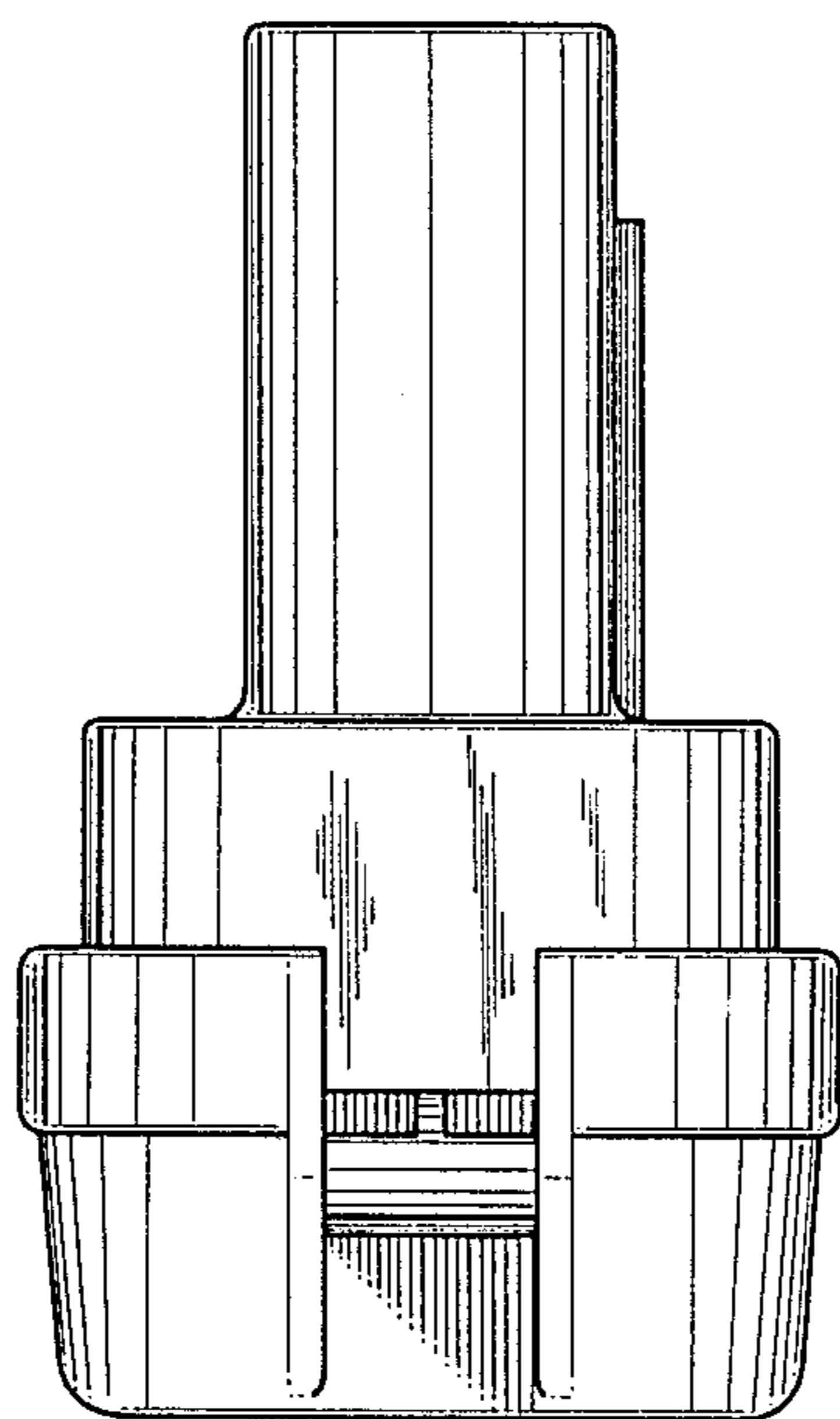

FIG. 4

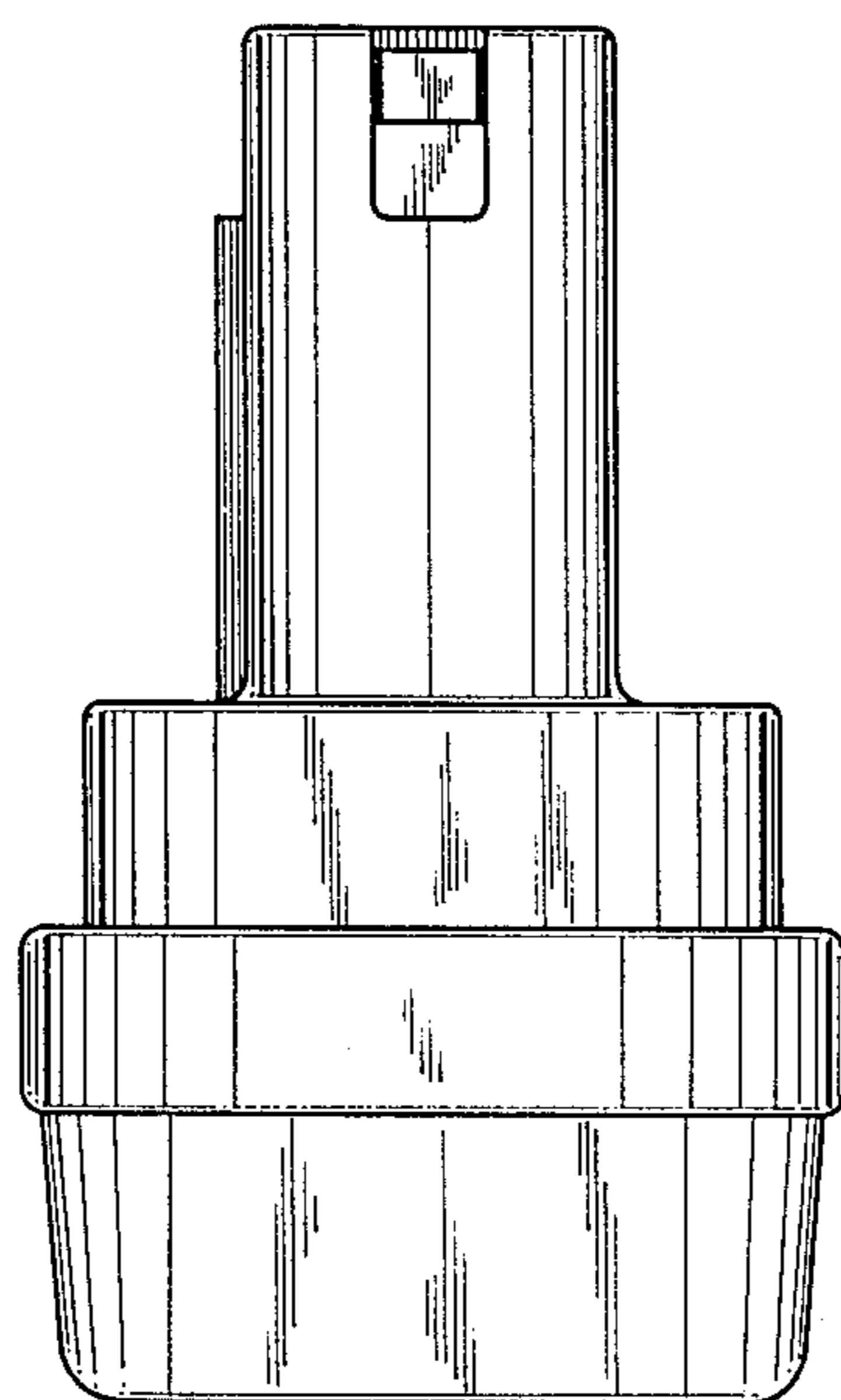

FIG. 5

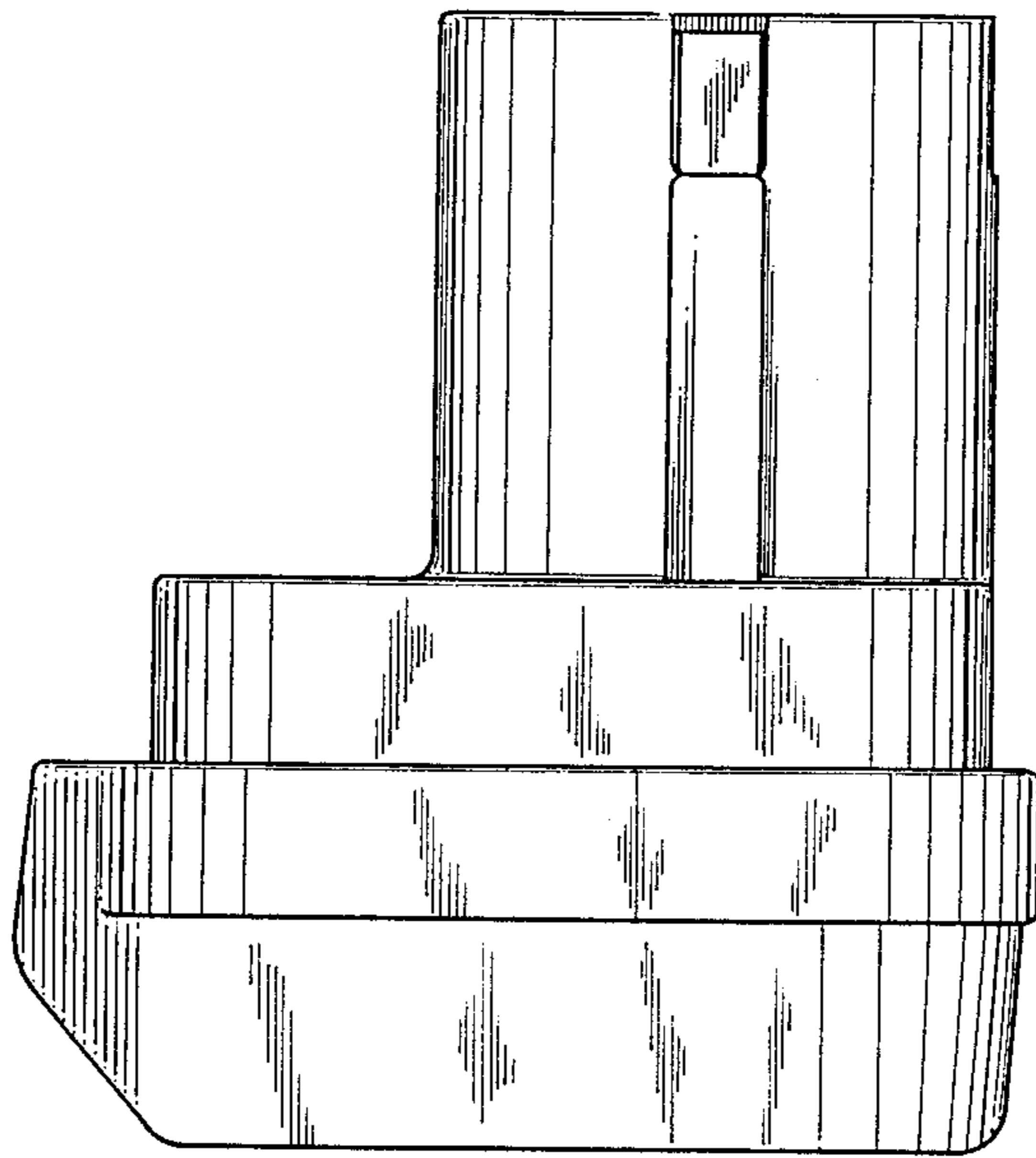

FIG. 2

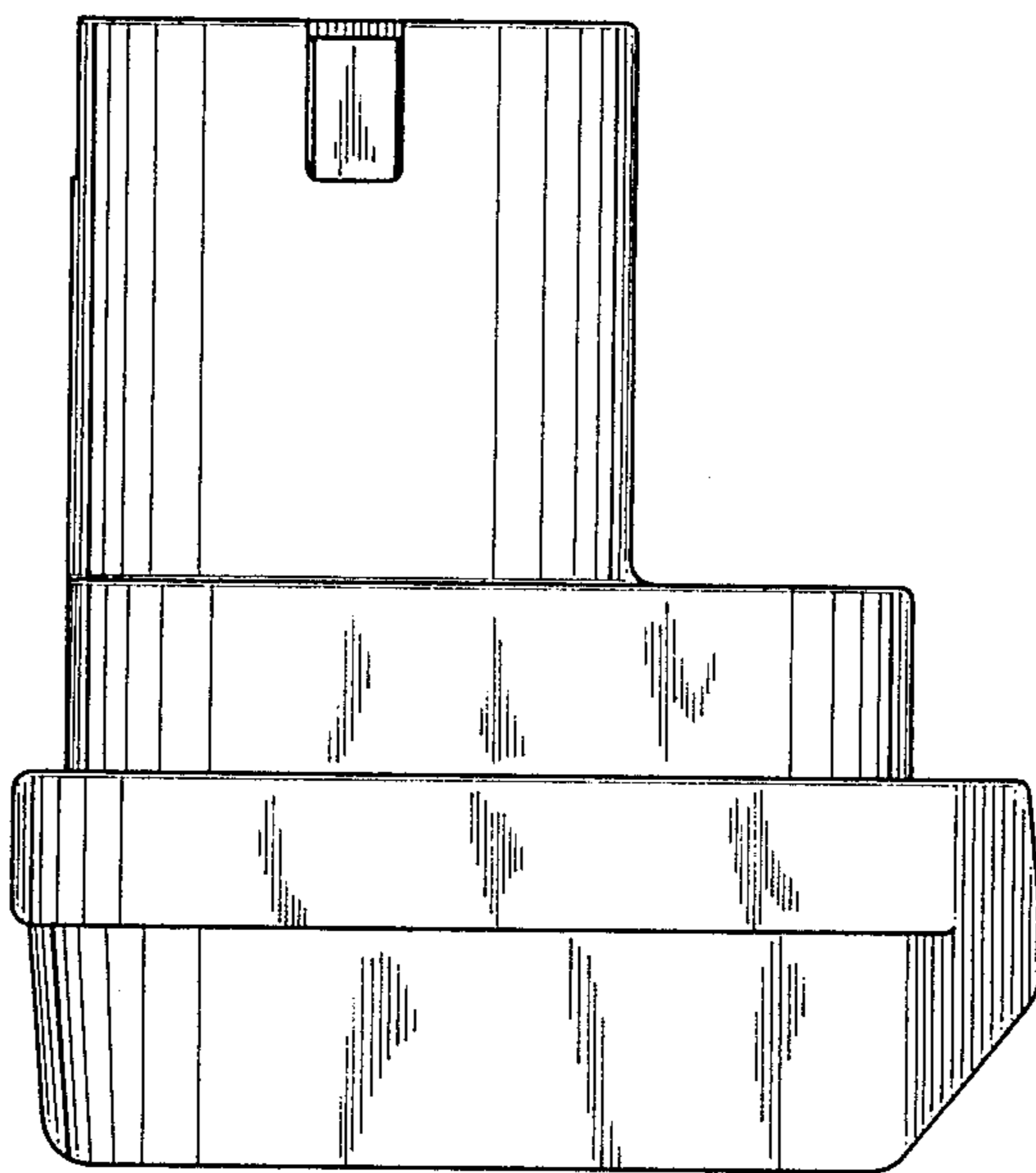

FIG. 3

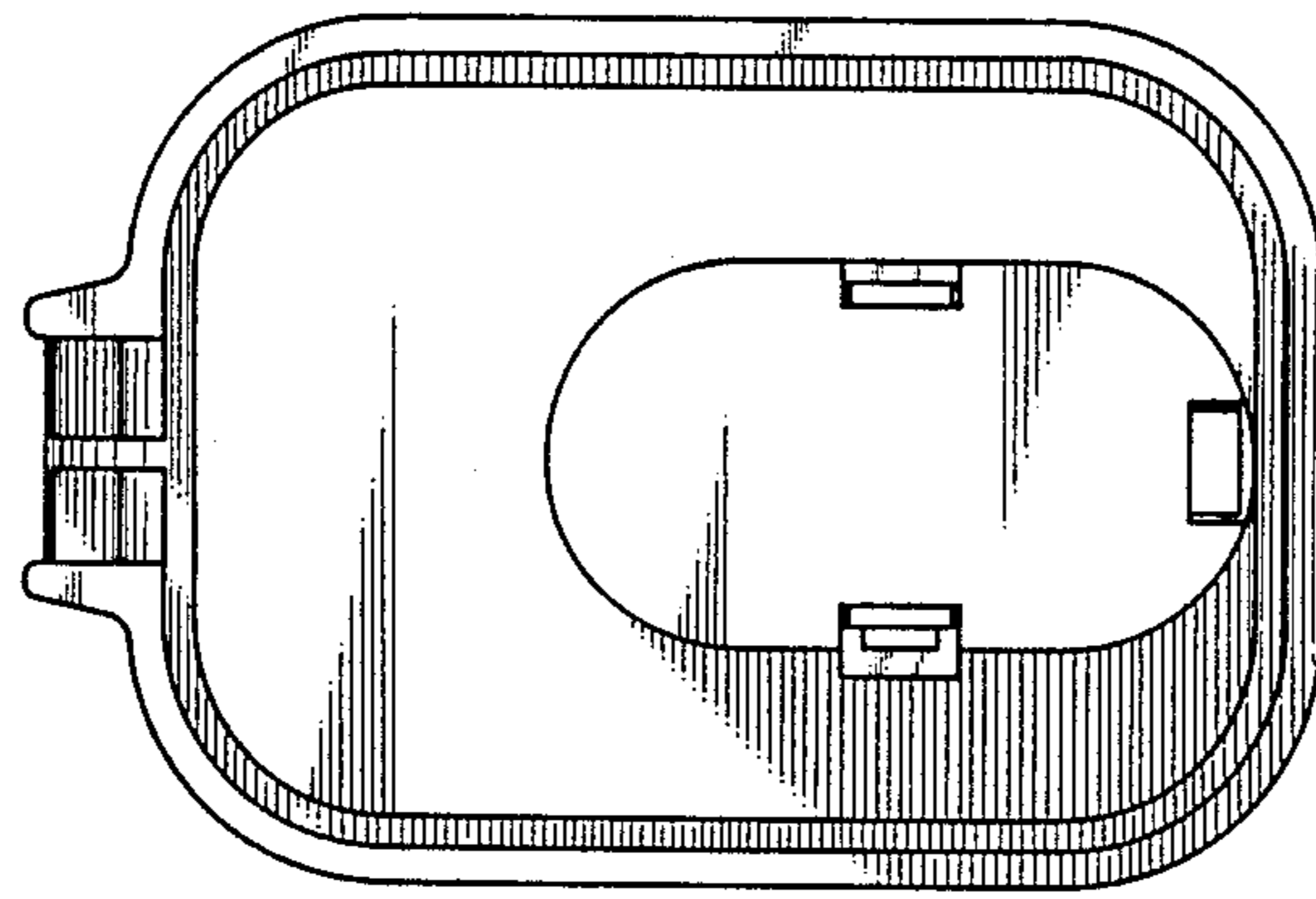

FIG. 6

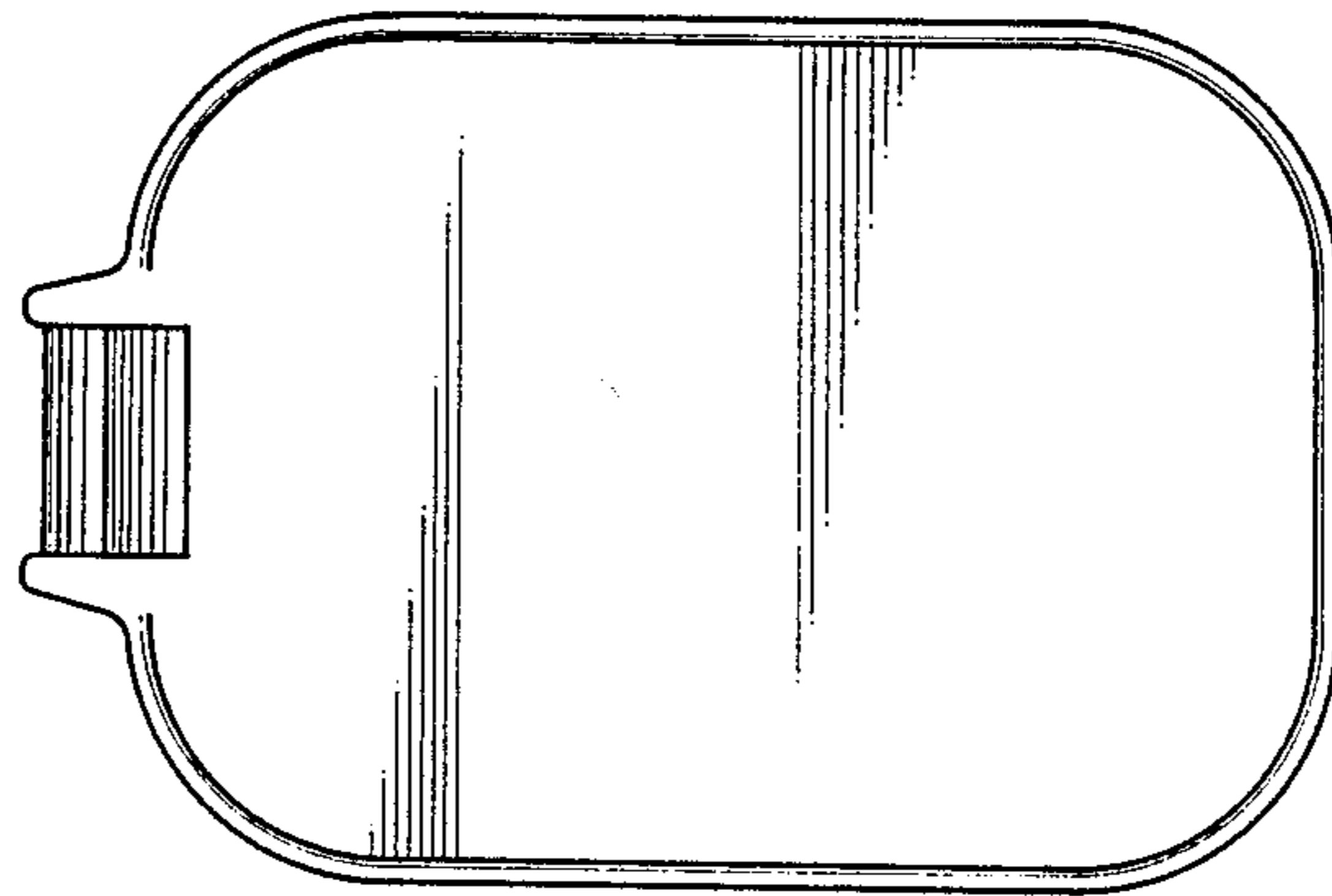

FIG. 7