

[54] **HOUSING FOR A TOY STEERING GEAR ROD**

[75] **Inventor: Ole V. Poulsen, Vejle, Denmark**

[73] **Assignee: Interlego A.G., Switzerland**

[**] **Term: 14 Years**

[21] **Appl. No.: 127,873**

[22] **Filed: Dec. 2, 1987**

[52] **U.S. Cl. D21/141; D21/108**

[58] **Field of Search D21/59, 108, 109, 145; 446/85, 117, 119, 121, 124, 125**

[56] **References Cited**

U.S. PATENT DOCUMENTS

D. 233,680	11/1974	Christiansen	D21/108
D. 290,477	6/1987	Ryaa et al.	D21/108
D. 290,721	7/1987	Ryaa et al.	D21/108
D. 291,460	8/1987	Mazzoleni	D21/108
2,609,638	9/1952	Lindenmeyer	D21/108
3,528,192	9/1970	Meates	446/124

OTHER PUBLICATIONS

J. C. Whitney & Co. Catalog #454D, 1985, p. 218, left side of page; Steering, Suspension & Chassis Parts.

Primary Examiner—Charles A. Rademaker
Assistant Examiner—Alicia A. Farrell
Attorney, Agent, or Firm—Kane, Dalsimer, Sullivan, Kurucz, Levy, Eisele and Richard

[57] **CLAIM**

The ornamental design for a housing for a toy steering gear rod, as shown and described.

DESCRIPTION

FIG. 1 is a top perspective view of the housing for a toy steering gear rod showing my new design, FIG. 2 is a bottom perspective view thereof, FIG. 3 is a top plan view thereof, FIG. 4 is a side elevational view thereof; the side opposite being identical, FIG. 5 is a bottom plan view thereof, FIG. 6 is a front elevational view thereof, and FIG. 7 is a rear elevational view thereof.

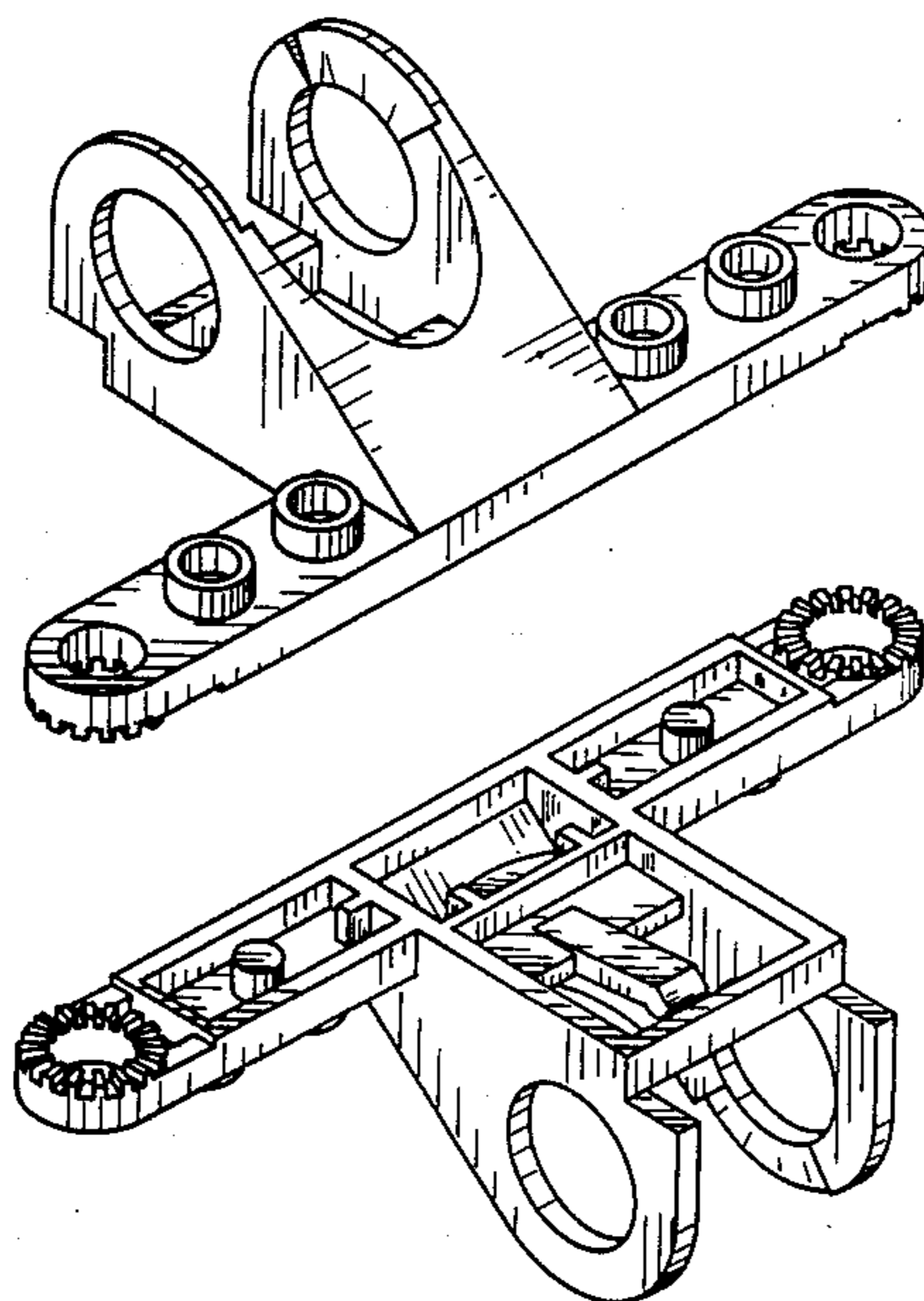

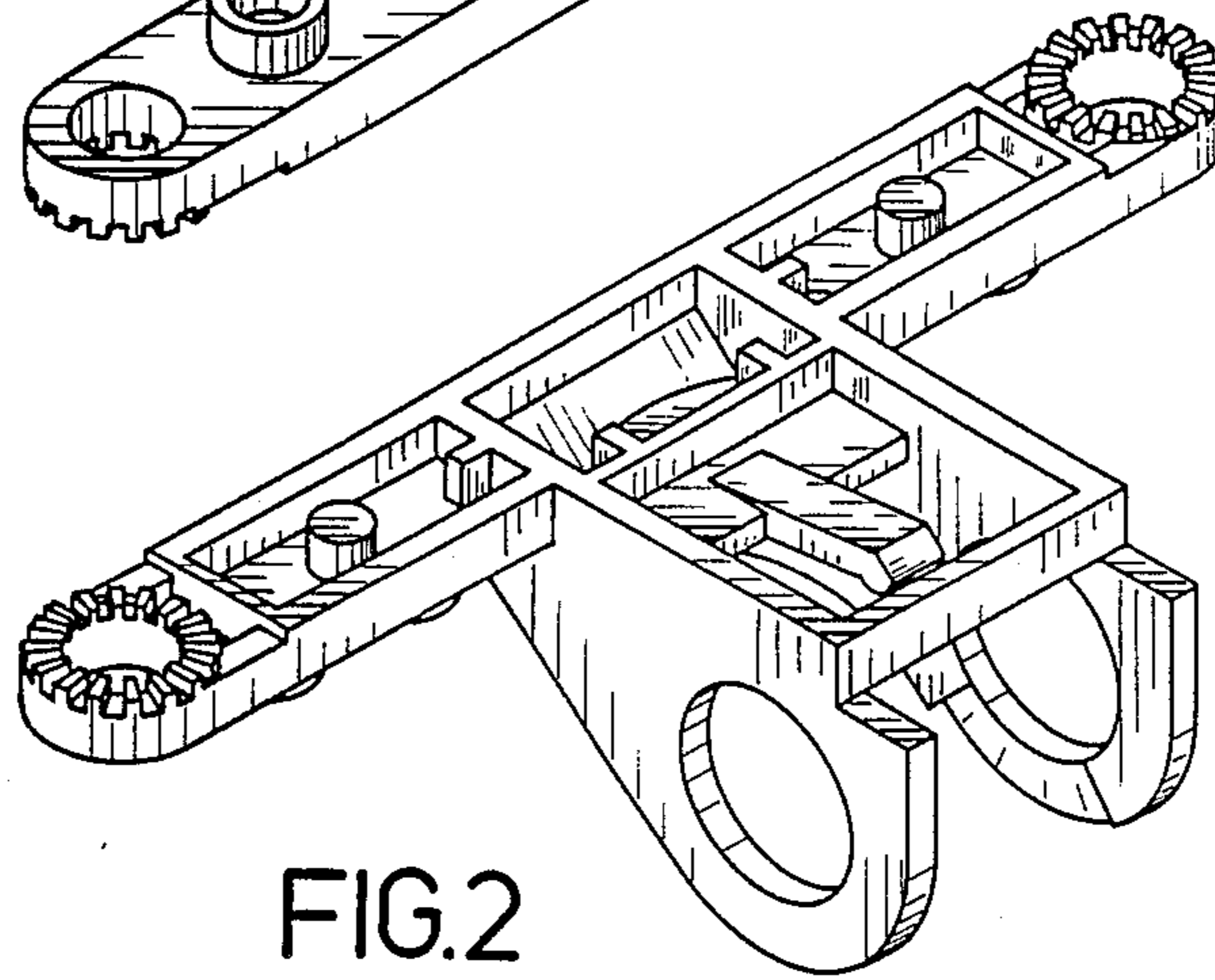
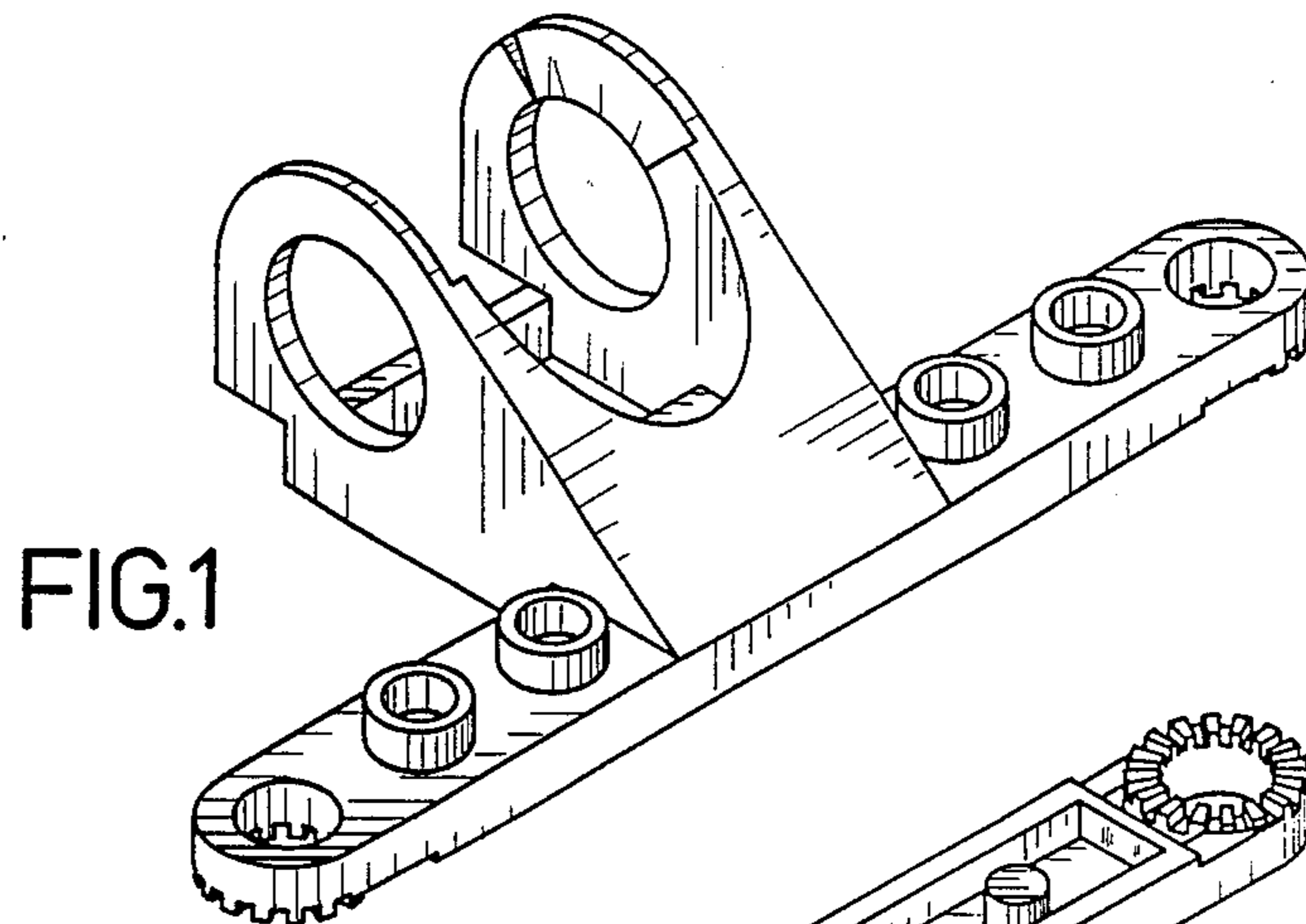

FIG.3

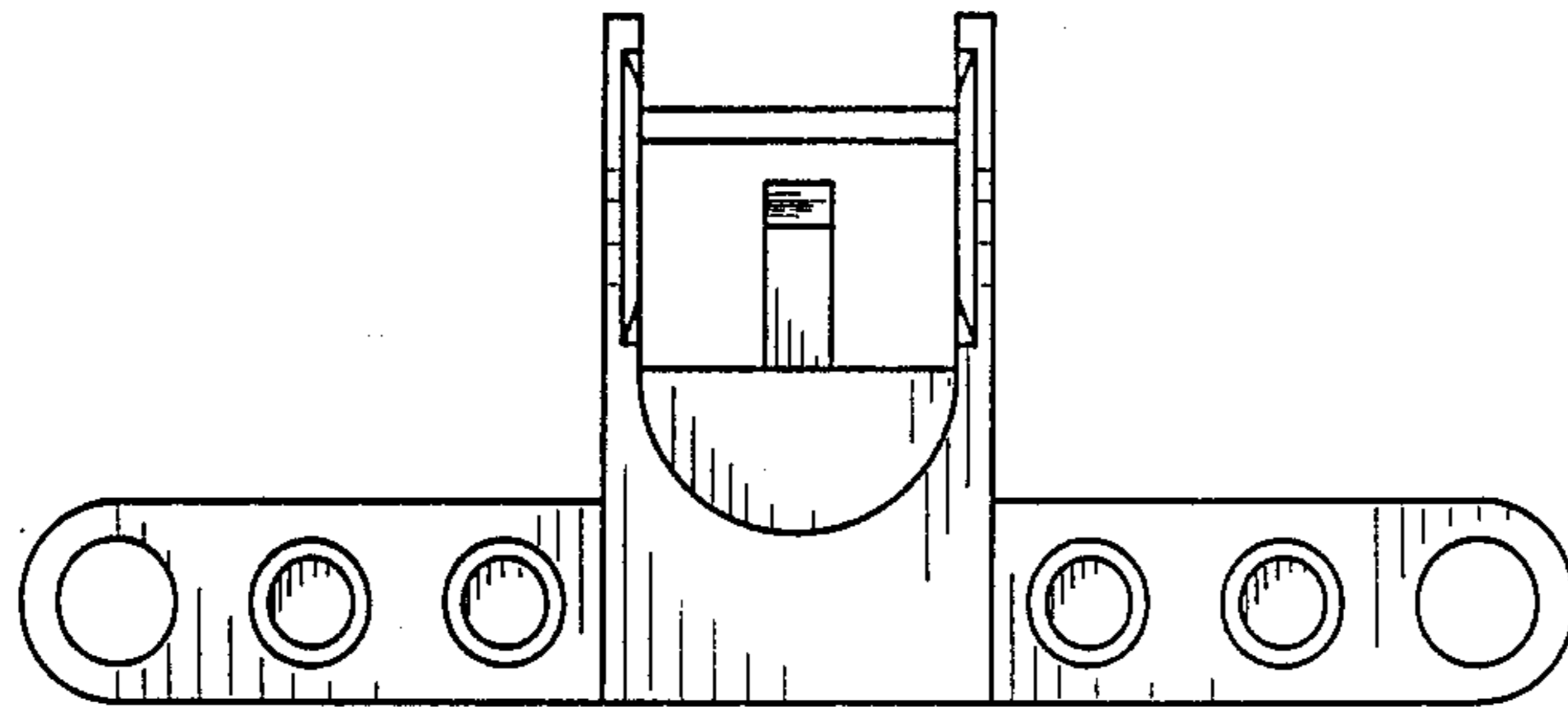

FIG.6

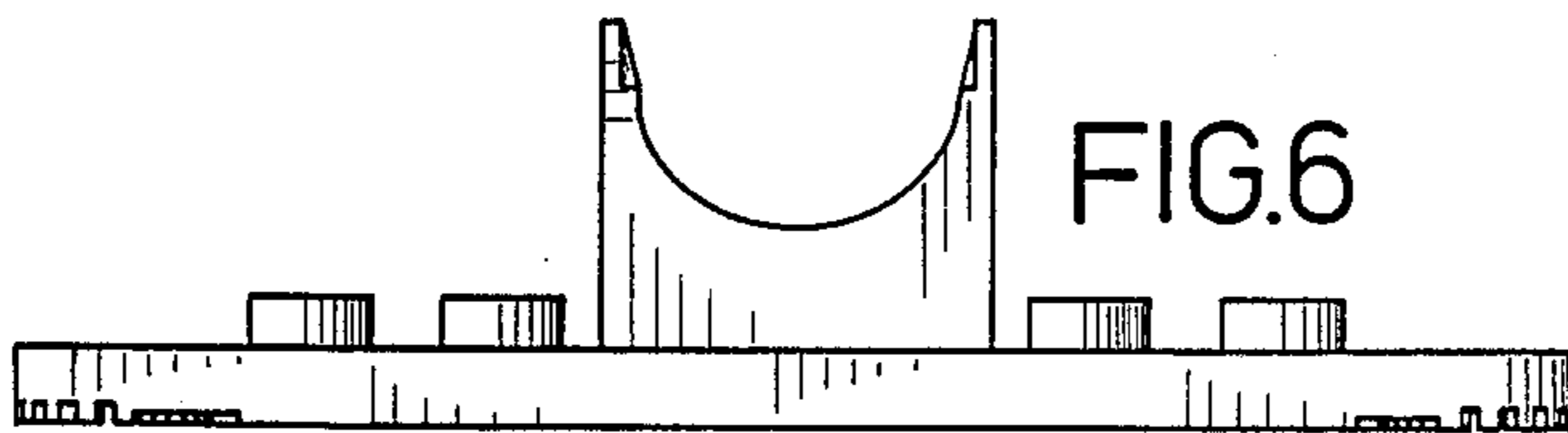

FIG.5

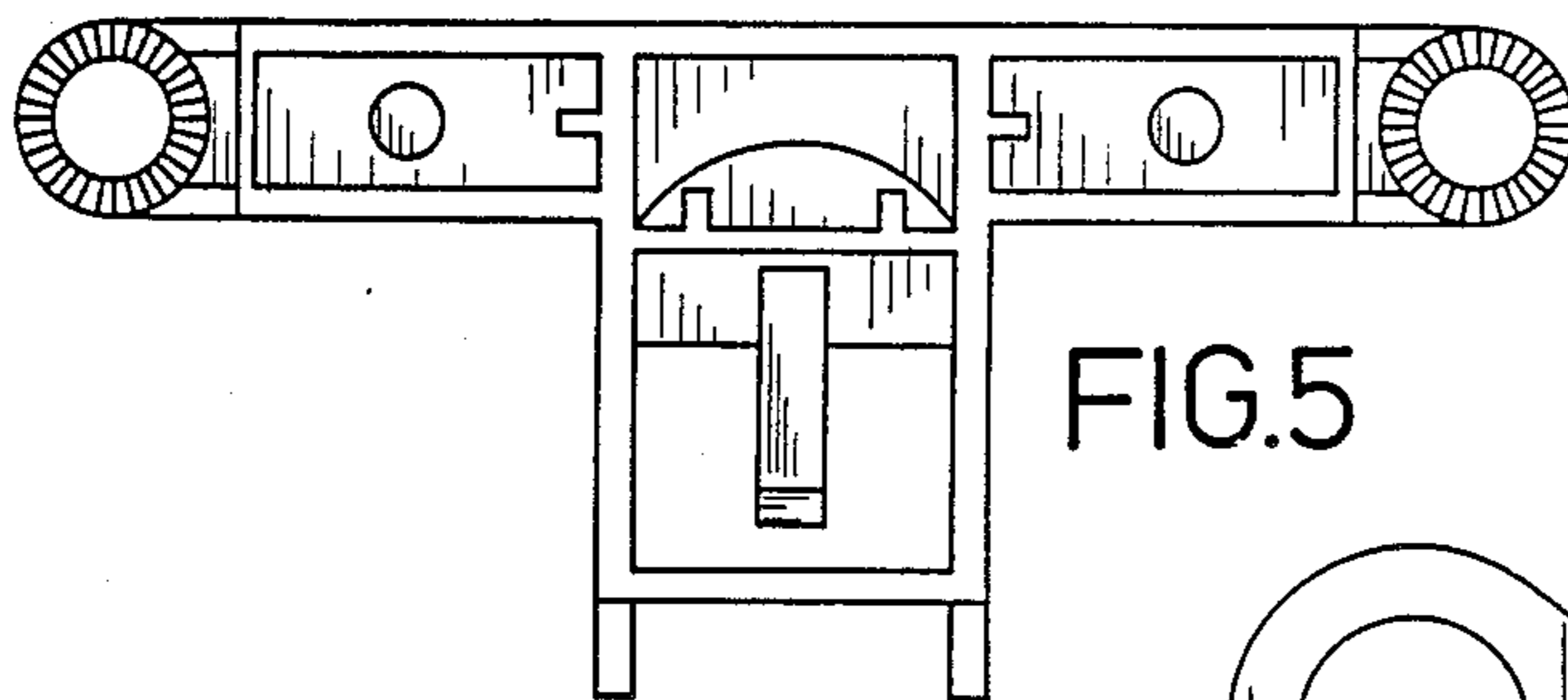

FIG.4

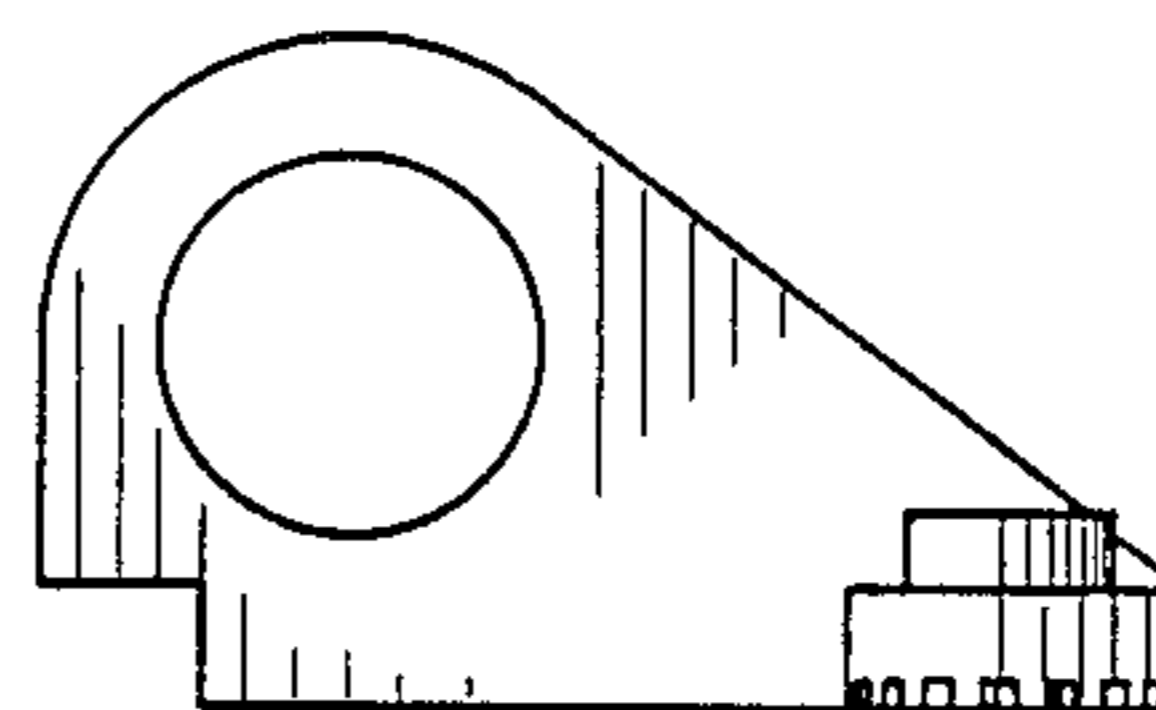

FIG.7

