

[54] FRONT CONTROL PANEL FOR A VEHICULAR COMBINED TAPE PLAYER AND RADIO OR THE LIKE

[75] Inventors: Clive A. Grinyer, London, England; Eugene P. Papak, Sterling Heights, Mich.

[73] Assignee: Ford Motor Company, Dearborn, Mich.

[**] Term: 14 Years

[21] Appl. No.: 856,094

[22] Filed: Apr. 17, 1986

[52] U.S. Cl. D14/258; D14/157

[58] Field of Search D14/124, 155, 157, 156, D14/161, 162, 164, 170, 175, 188, 257, 258; 455/344, 345, 347, 349, 351

[56] References Cited

U.S. PATENT DOCUMENTS

- D. 288,316 2/1987 Stoddard et al. D14/157
- D. 288,806 3/1987 Stoddard et al. D14/258
- D. 290,251 6/1987 Stoddard et al. D14/258

OTHER PUBLICATIONS

High Fidelity Magazine—Apr. '85, p. 38, (upper left). Lincoln—Mercury Luxury Sound Systems.

Primary Examiner—Melvin B. Feifer
Assistant Examiner—W. Krawczewicz
Attorney, Agent, or Firm—Mark L. Mollon; Paul K. Godwin

[57] CLAIM

The ornamental design for front control panel for a vehicular combined tape player and radio or the like, as shown and described.

DESCRIPTION

FIG. 1 is a front, top and right side perspective view of a front control panel for a vehicular combined tape player and radio or the like showing my new design; FIG. 2 is a top plan view thereof; FIG. 3 is a front elevational view thereof; FIG. 4 is a bottom plan view thereof; FIG. 5 is a left side elevational view thereof; and FIG. 6 is a right side elevational view thereof. The broken lines in the drawing show environment only.

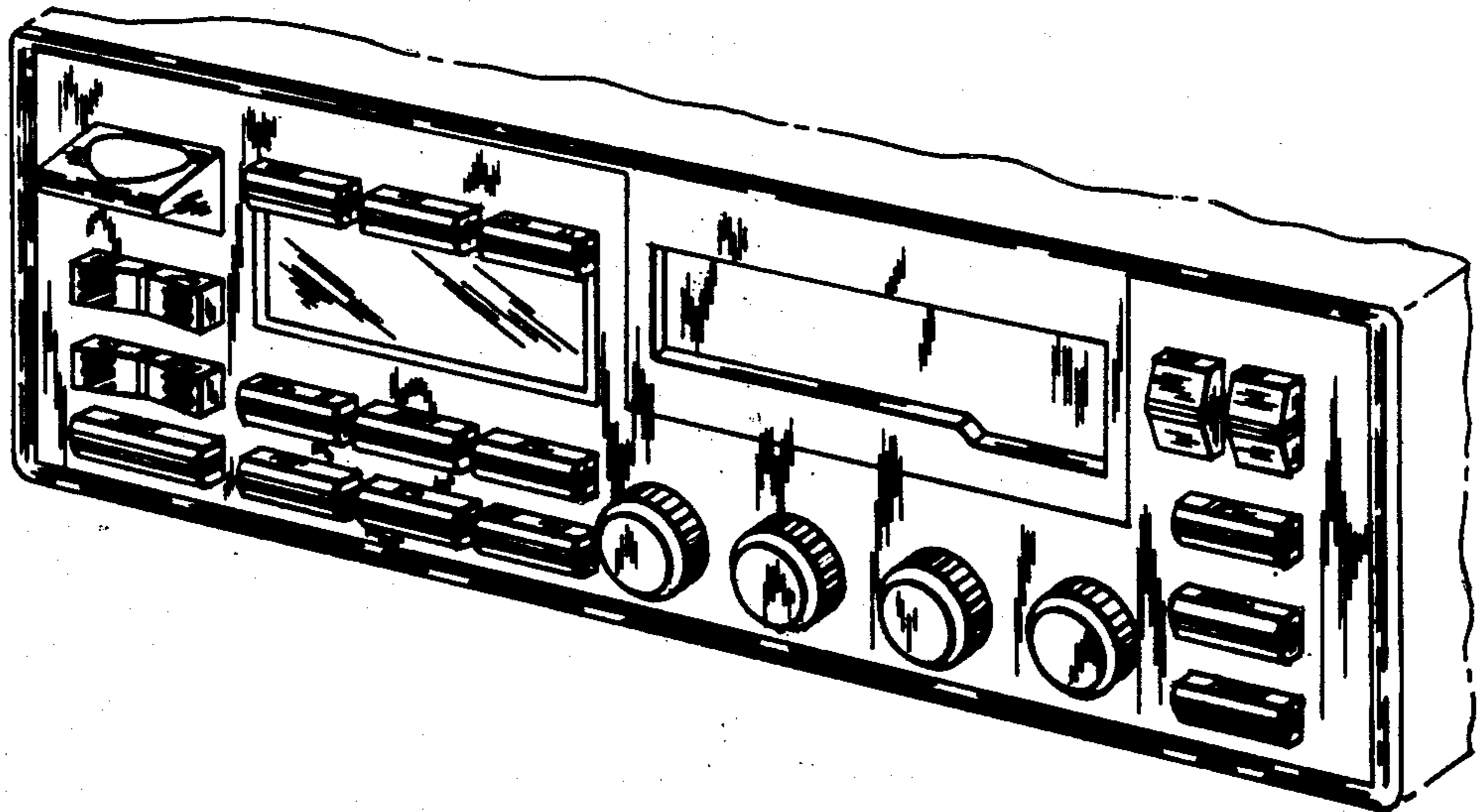

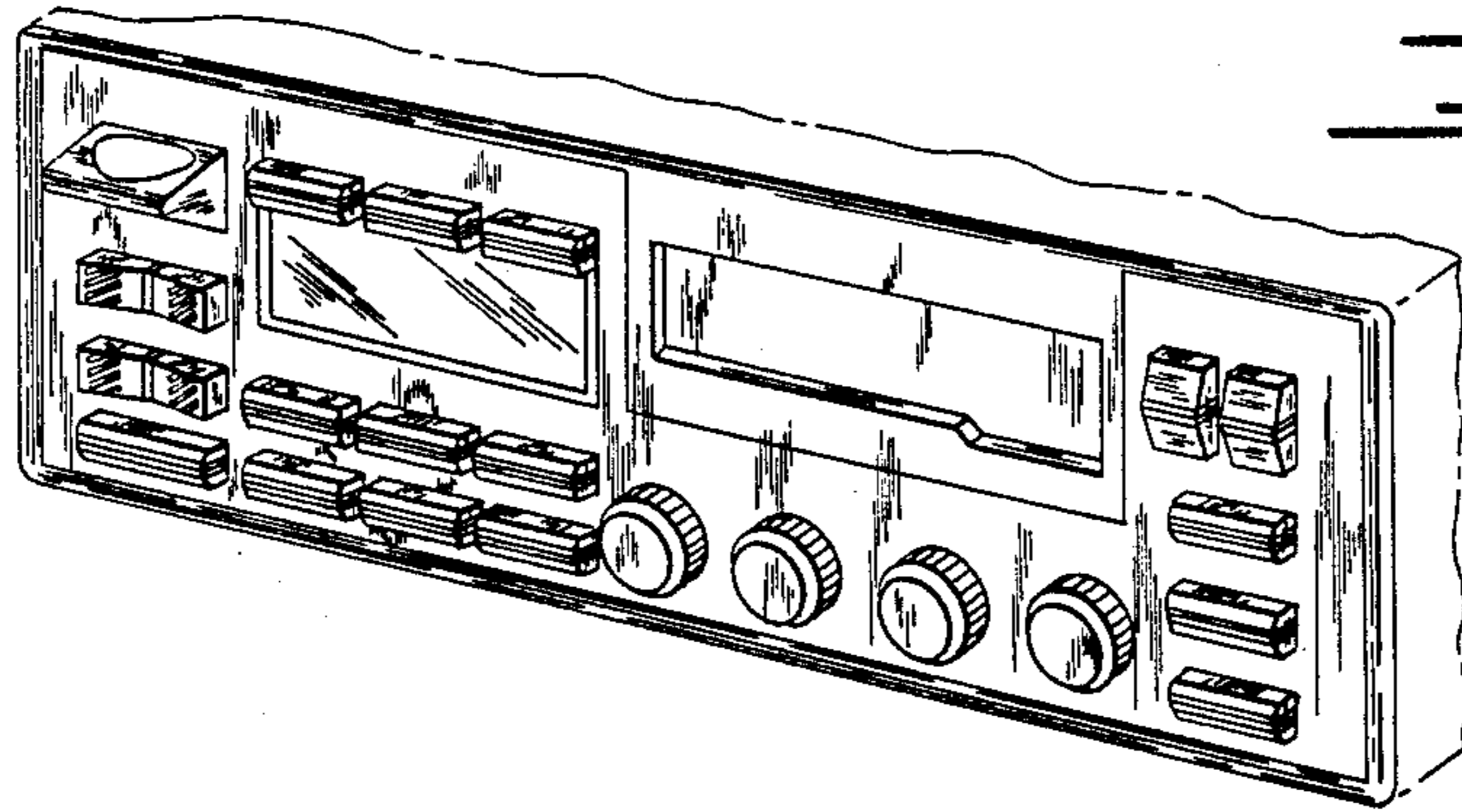

Fig. 1.



Fig. 2.

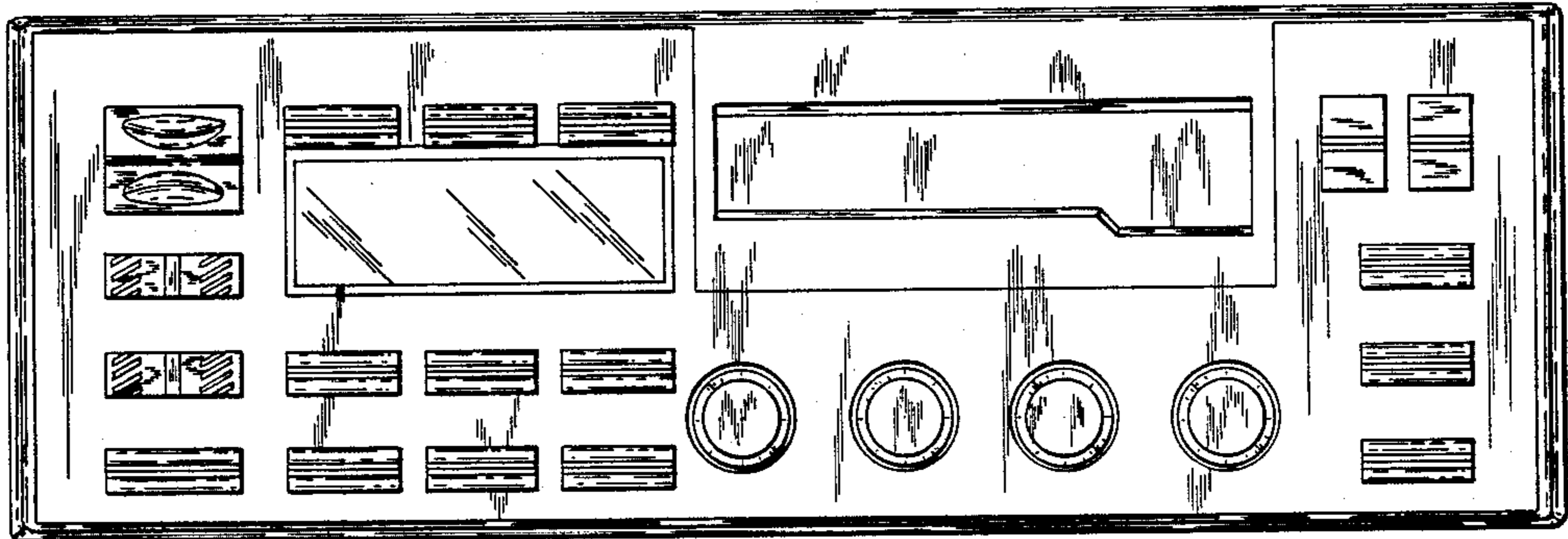

Fig. 3.

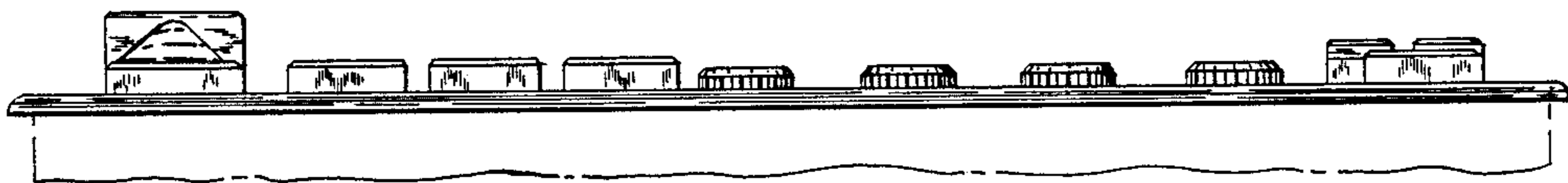

Fig. 4.

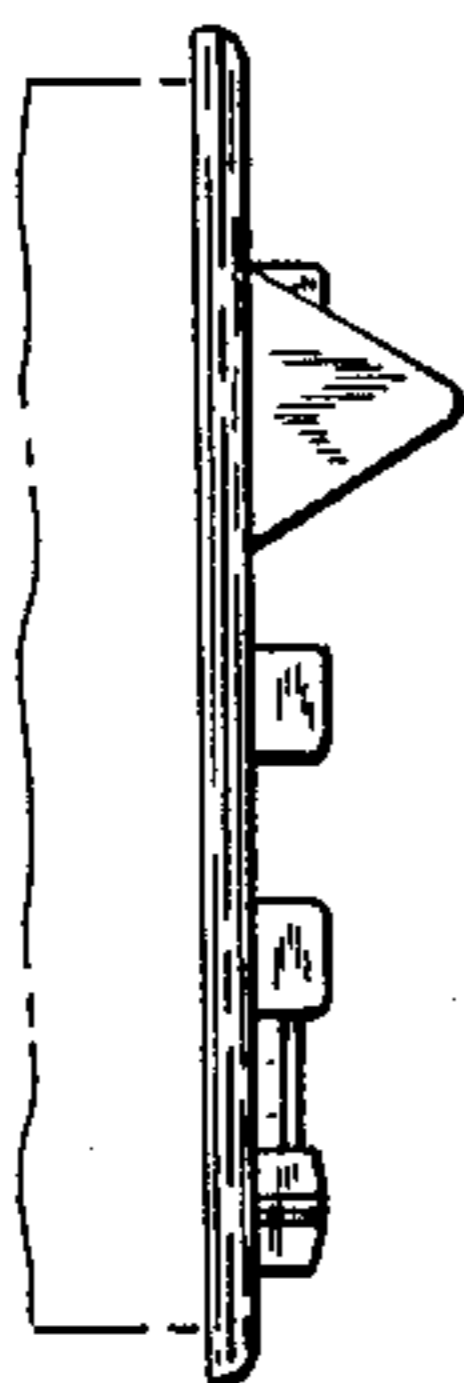

Fig. 5.

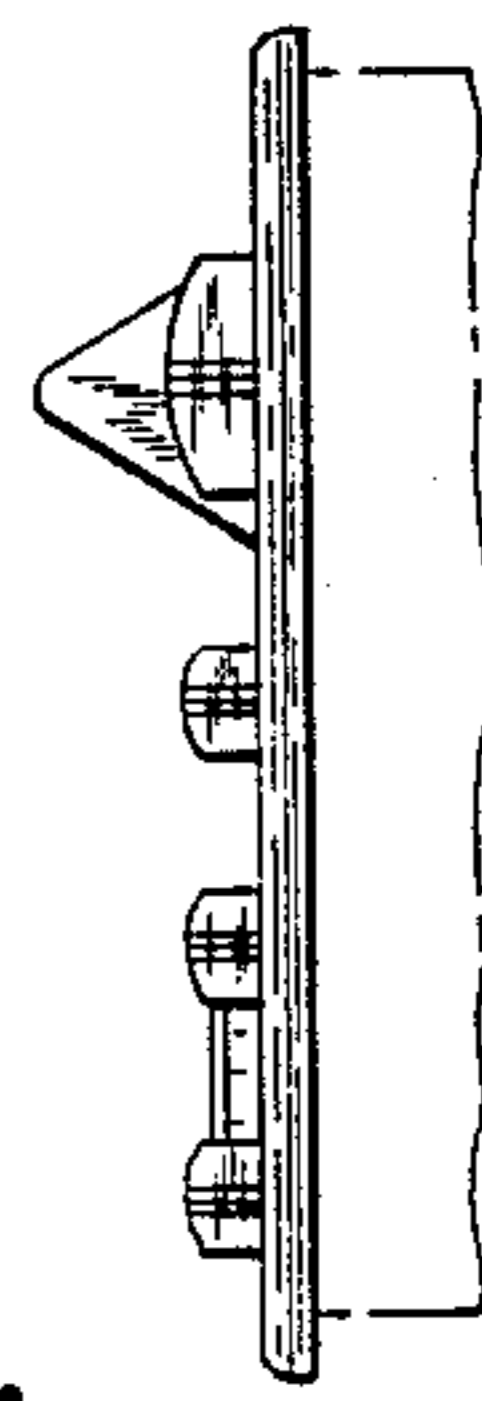

Fig. 6.