

[54] TAPE MEASURE CASE

[76] Inventors: Koichi Hara, 30, Sangayama-cho;  
Akira Hara, 1250-25, Katsuragi-cho,  
both of Kishiwada-shi, Osaka, Japan

[\*\*] Term: 14 Years

[21] Appl. No.: 920,349

[22] Filed: Oct. 17, 1986

[52] U.S. Cl. .... D10/12

[58] Field of Search ..... D10/72, 71, 70;  
33/137 R, 138 R, 403; 202/84.8

[56] References Cited

U.S. PATENT DOCUMENTS

- D. 71,257 10/1926 Simpson ..... D10/72
- D. 178,567 8/1956 Holscher ..... D10/72 X

- D. 223,288 4/1972 Quenot ..... D10/72
- 2,563,674 8/1951 Coots ..... 33/403
- 3,186,657 6/1965 Roe ..... 242/84.8
- 4,056,235 11/1977 Roe ..... 242/84.8 X

Primary Examiner—Nelson C. Holtje  
Attorney, Agent, or Firm—Armstrong, Nikaido,  
Marmelstein, Kubovcik & Murray

[57] CLAIM

The ornamental design for tape measure case, as shown and described.

DESCRIPTION

FIG. 1 is a top plan view of a tape measure case showing our new design;  
FIG. 2 is a bottom plan view thereof;  
FIG. 3 is a cross sectional view thereof as taken from line 3—3 of FIG. 1;  
FIG. 4 is a top and front perspective view thereof.

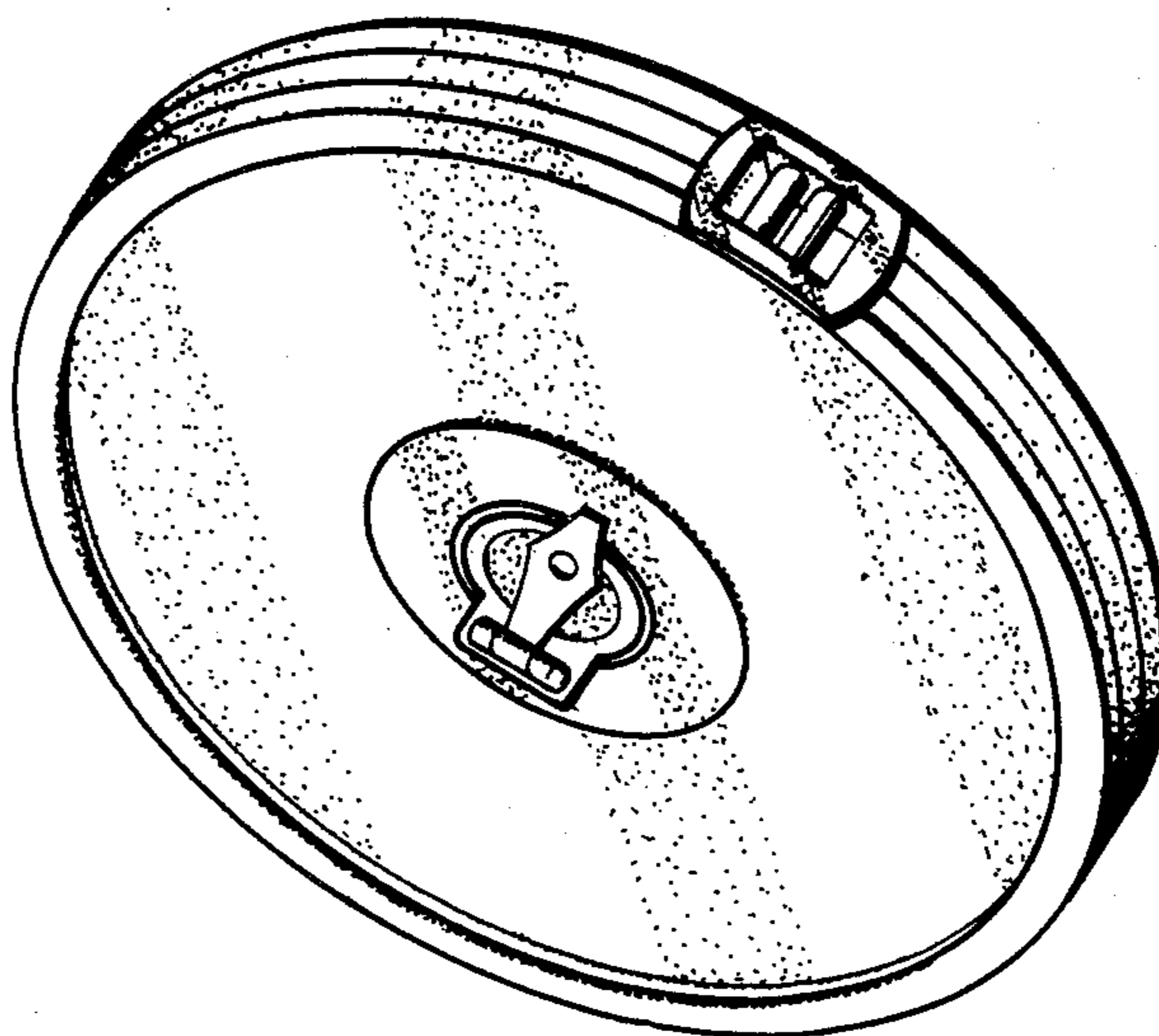

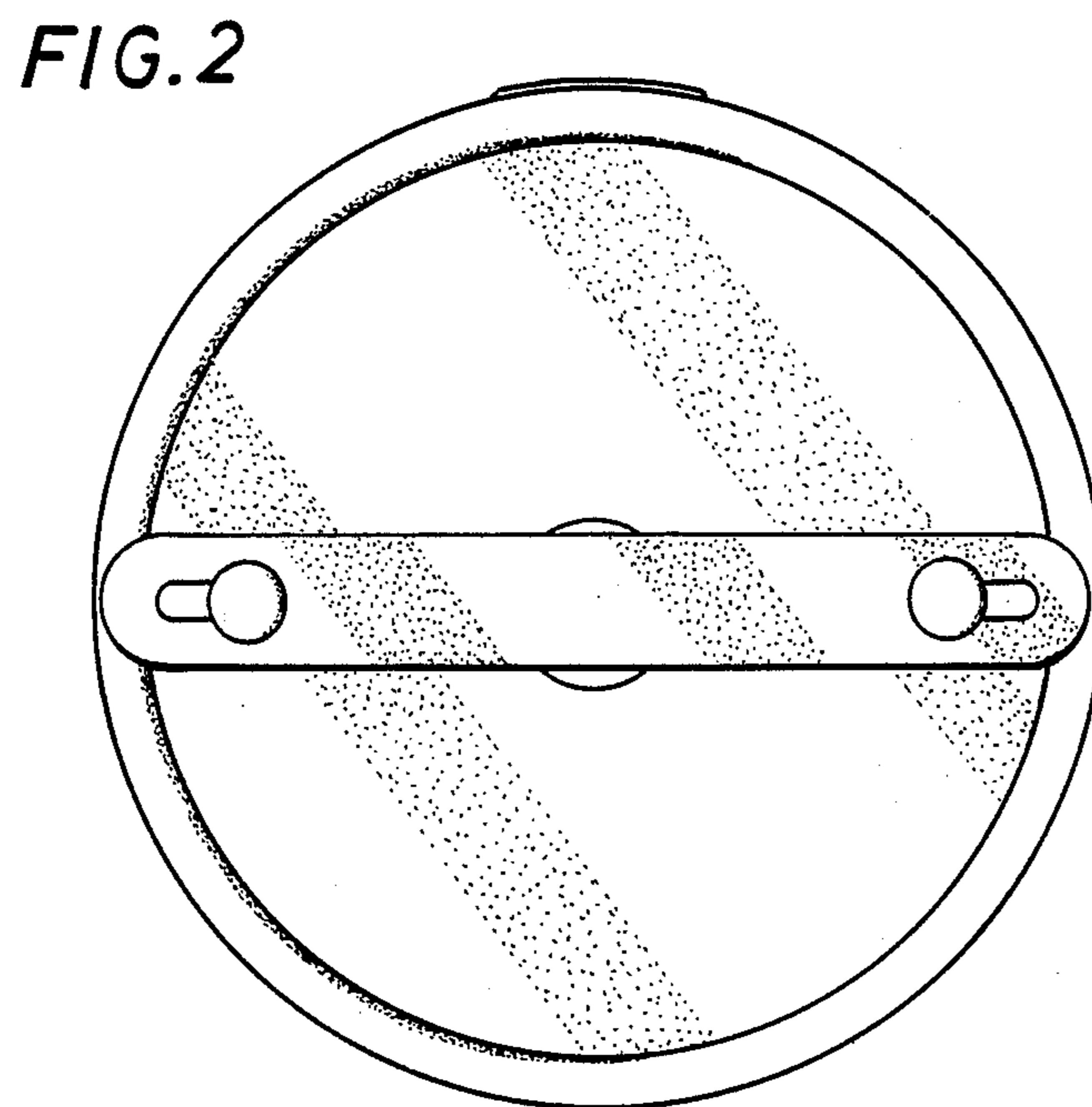
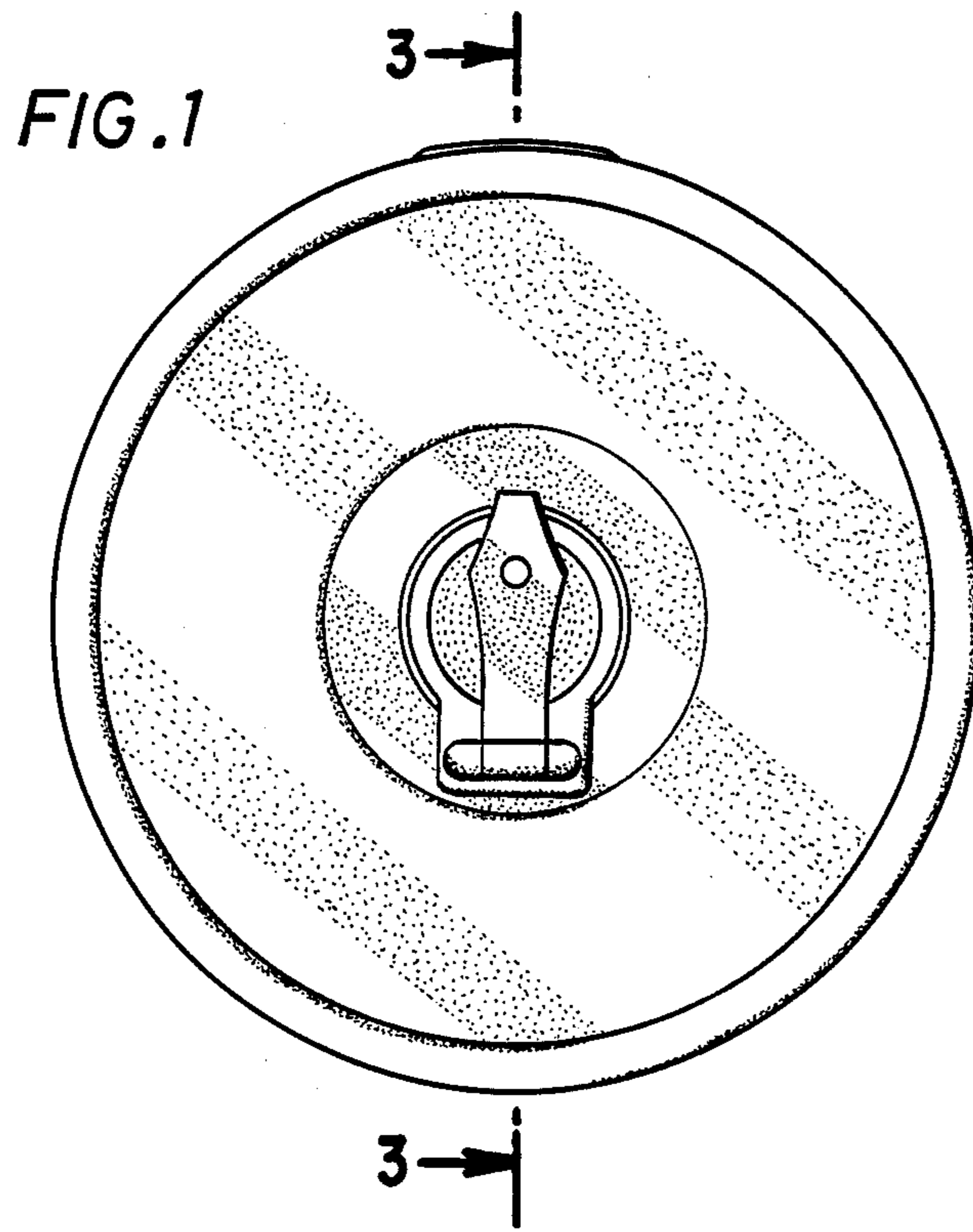

FIG.3

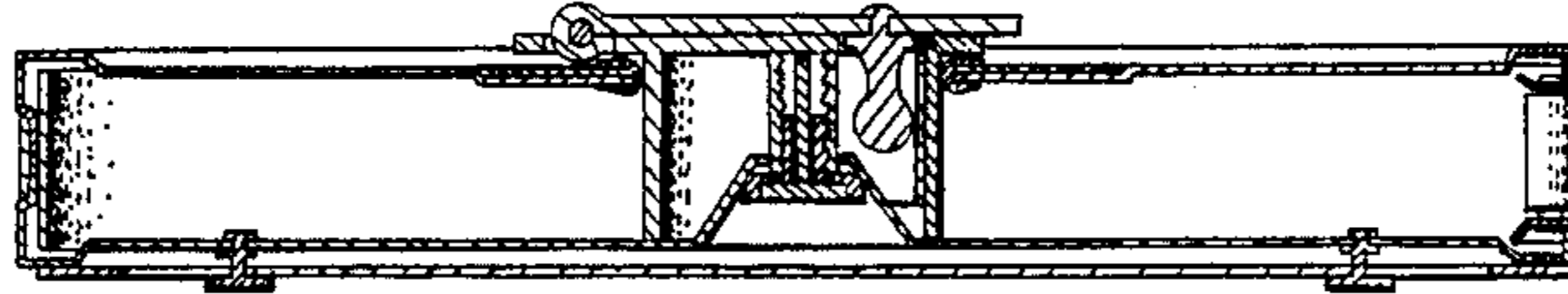

FIG.4

