

# United States Patent [19]

Charet et al.

[11] Patent Number: **Des. 304,304**

[45] Date of Patent: **\*\* Oct. 31, 1989**

[54] **FLIP UP MODULAR DIGITAL CLOCK FOR  
AUTOMOBILE CONTROL PANELS**

[75] Inventors: **Pierre Charet; Duke Kraai, both of  
Miami, Fla.**

[73] Assignee: **Rally Manufacturing, Inc., Miami,  
Fla.**

[\*\*] Term: **14 Years**

[21] Appl. No.: **860,778**

[22] Filed: **May 7, 1986**

[52] U.S. Cl. .... **D10/15; D10/18;  
D10/26**

[58] Field of Search ..... **D10/1, 15, 18, 24-26,  
D10/122-126; 368/82-84, 239-242, 276-277,  
280-282, 285, 316-317**

[56] **References Cited**

**U.S. PATENT DOCUMENTS**

D. 131,209 1/1942 Kauffman ..... D10/18 X  
D. 163,378 5/1951 Gibbons ..... D10/31

D. 235,093 5/1975 Kroner ..... D10/18  
D. 274,042 5/1984 Bulgari ..... D10/18  
D. 286,751 11/1986 Hsieh ..... D10/2  
1,804,048 5/1931 Bosch ..... D10/18 X  
4,444,513 4/1984 Proeilochs ..... 368/223  
4,508,459 4/1985 Hashimoto ..... 368/277 X

*Primary Examiner*—Nelson C. Holtje  
*Attorney, Agent, or Firm*—Gilbert L. Wells

[57] **CLAIM**

The ornamental design for a flip up modular digital clock for automobile control panels, as shown.

**DESCRIPTION**

FIG. 1 is a top and right, front perspective view of a flip-up modular digital clock in an unfolded position; FIG. 2 is a front elevational view thereof in a folded position; FIG. 3 is a right side elevational view of FIG. 2, the left side view being a mirror image thereto; FIG. 4 is a rear elevational view of FIG. 2; FIG. 5 is a top plan view of FIG. 2; FIG. 6 is a bottom plan view thereof.

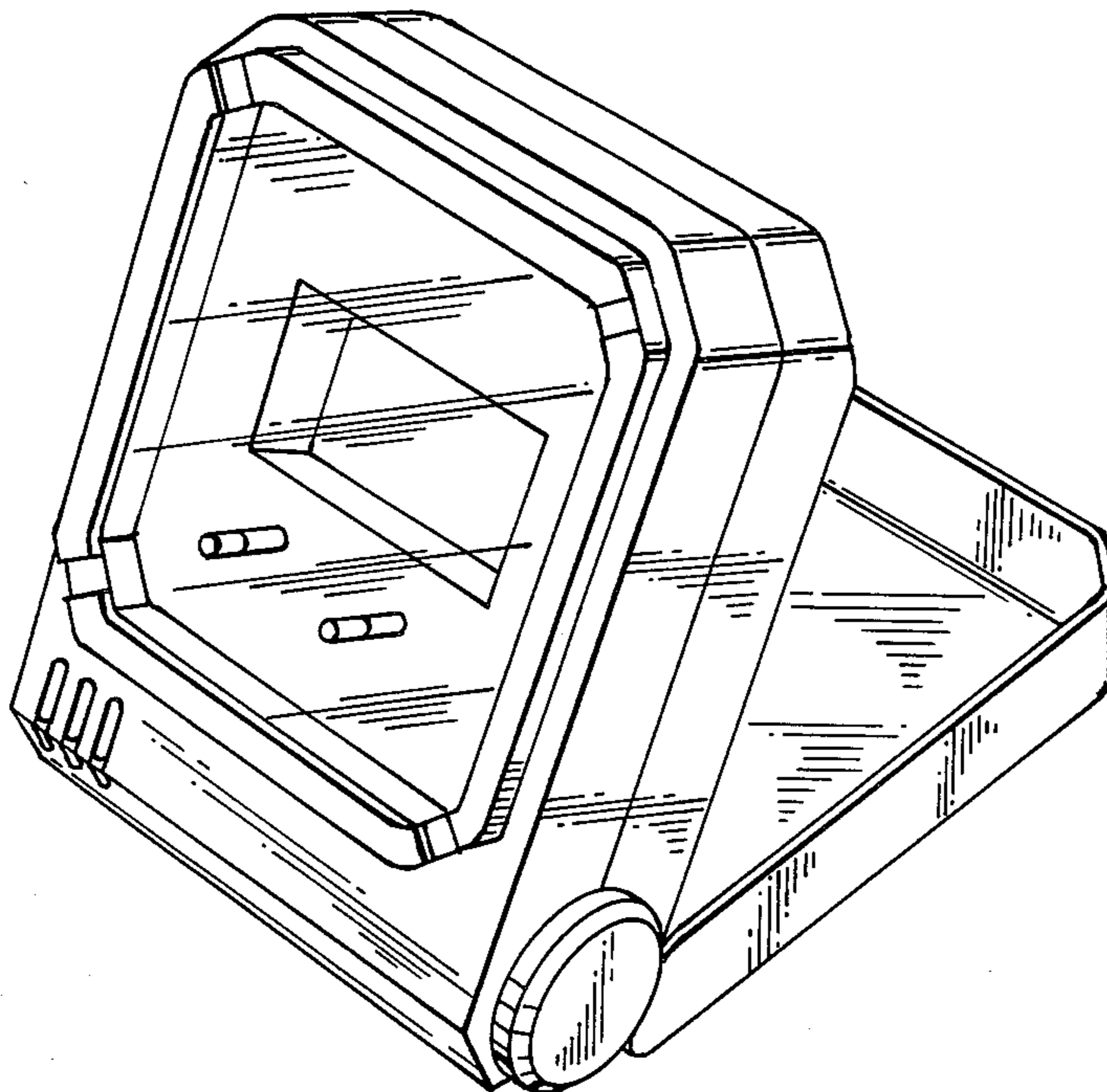

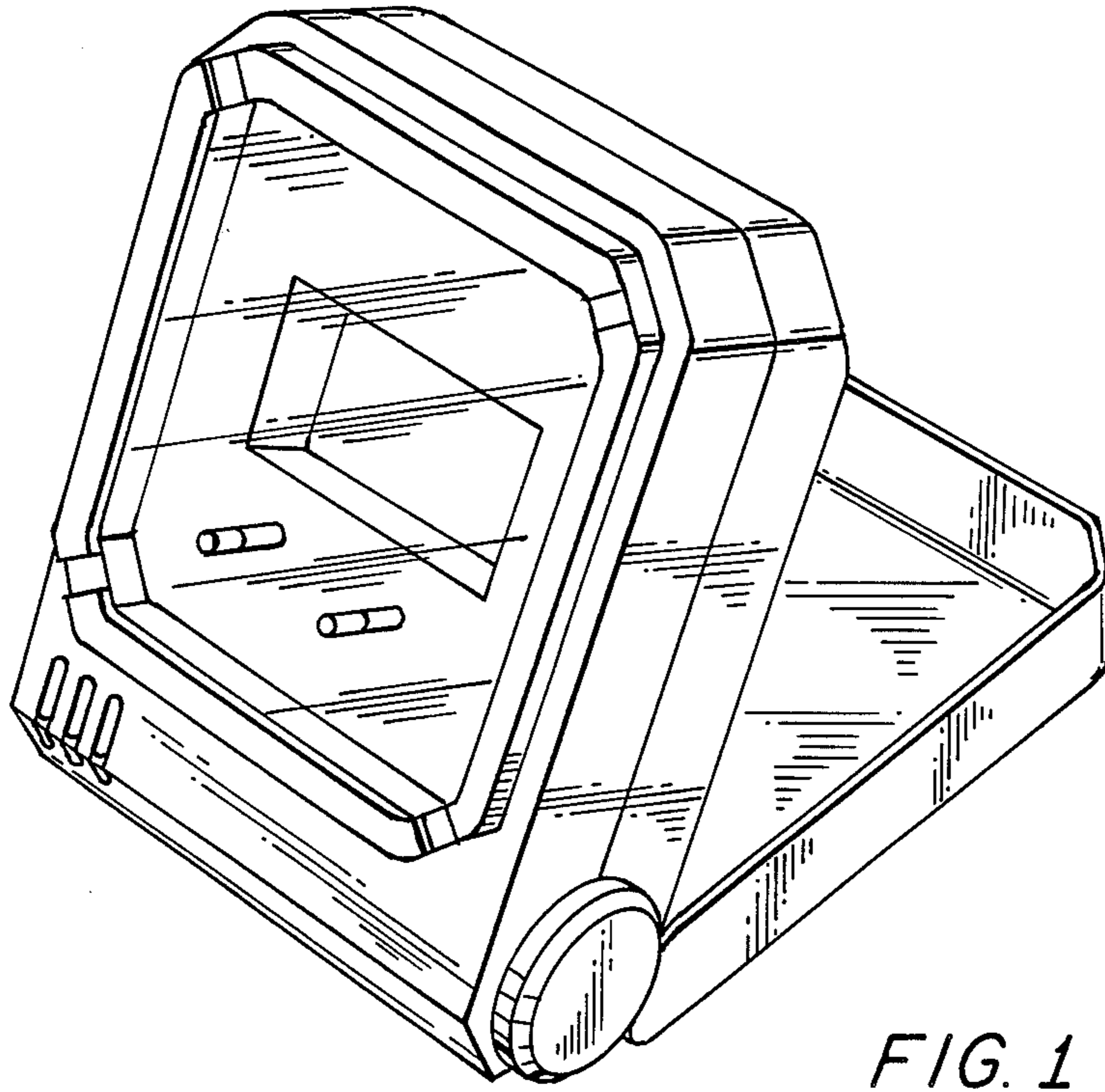

FIG. 1

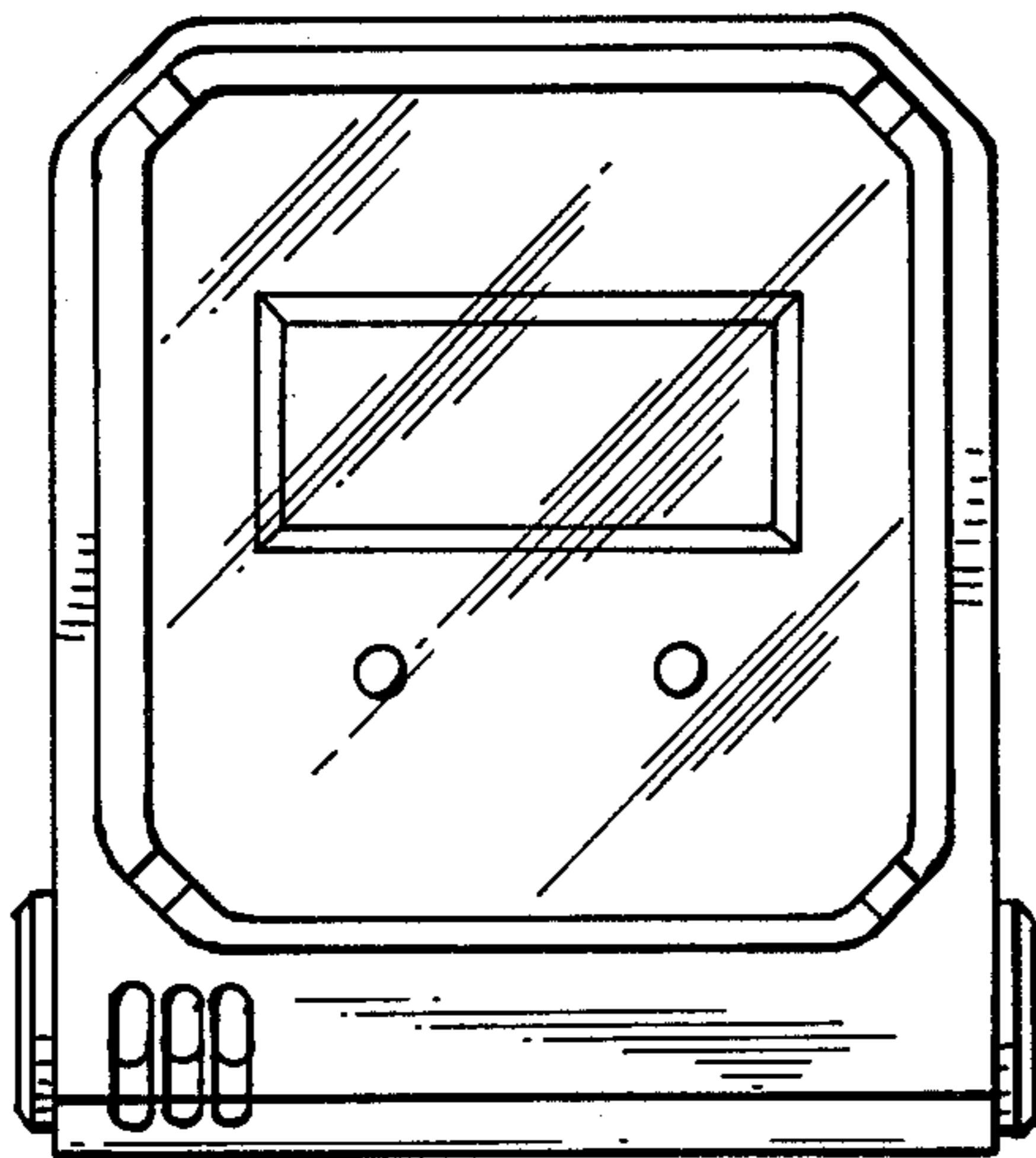

FIG. 2

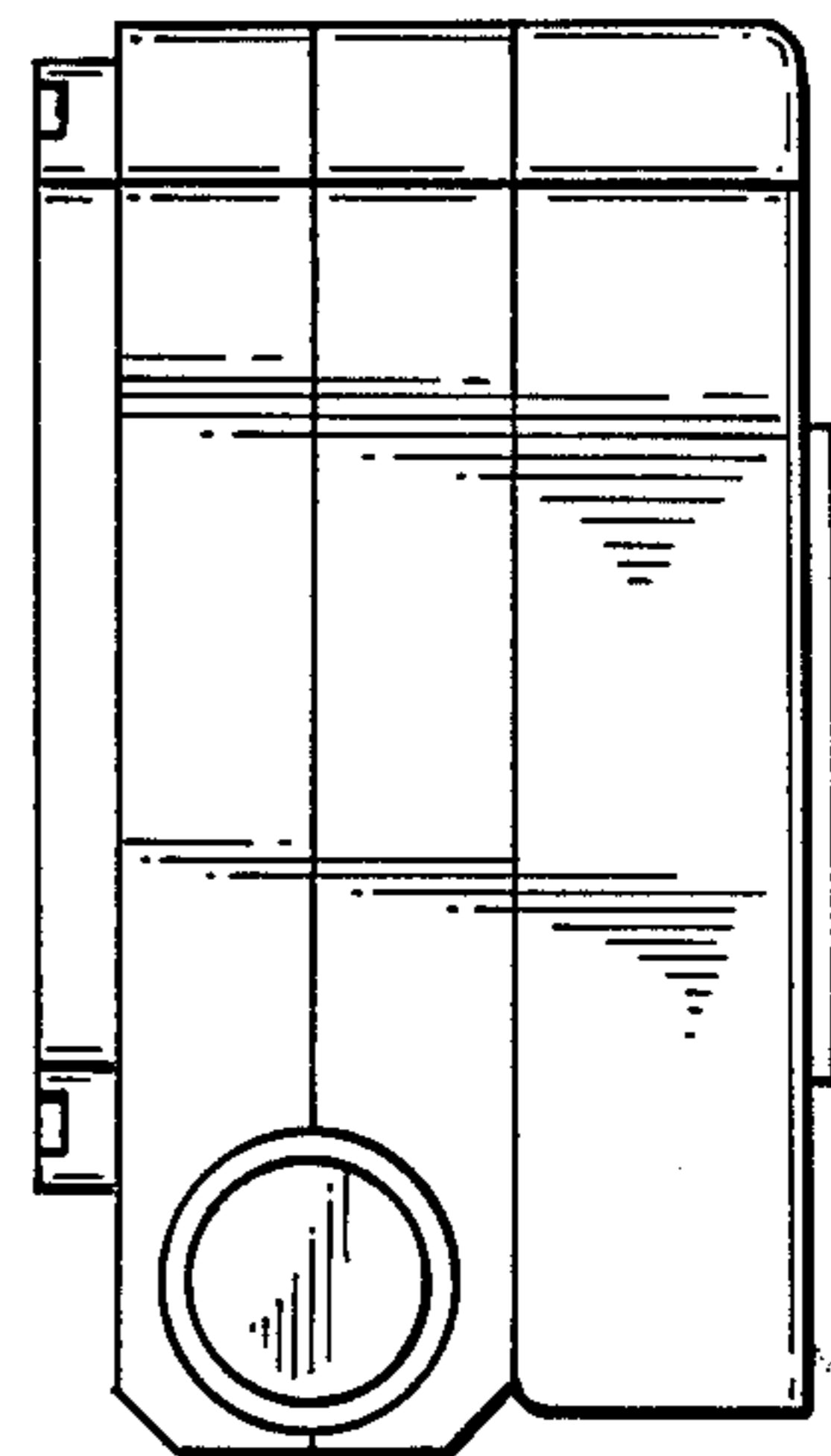

FIG. 3

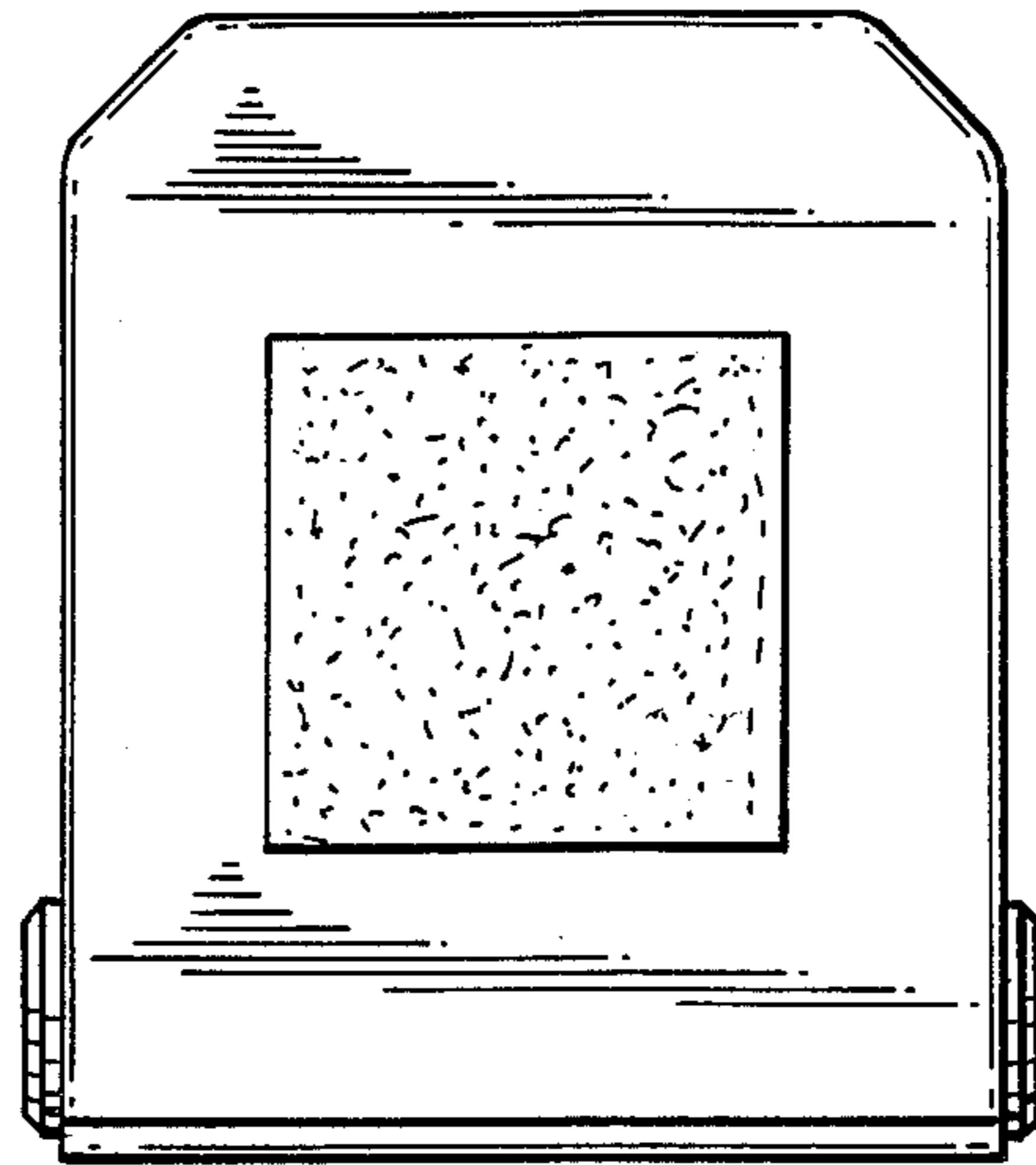

FIG. 4

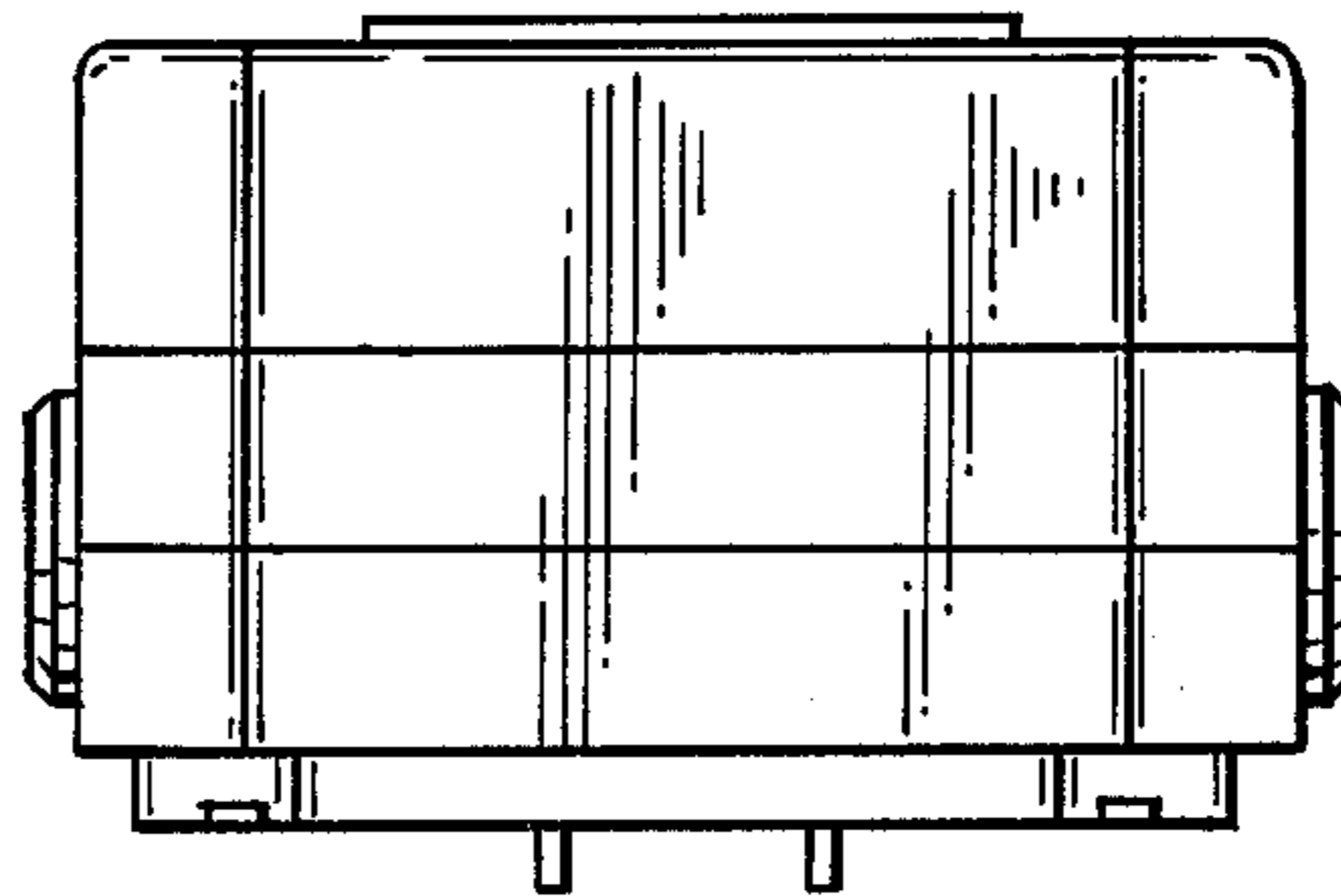

FIG. 5

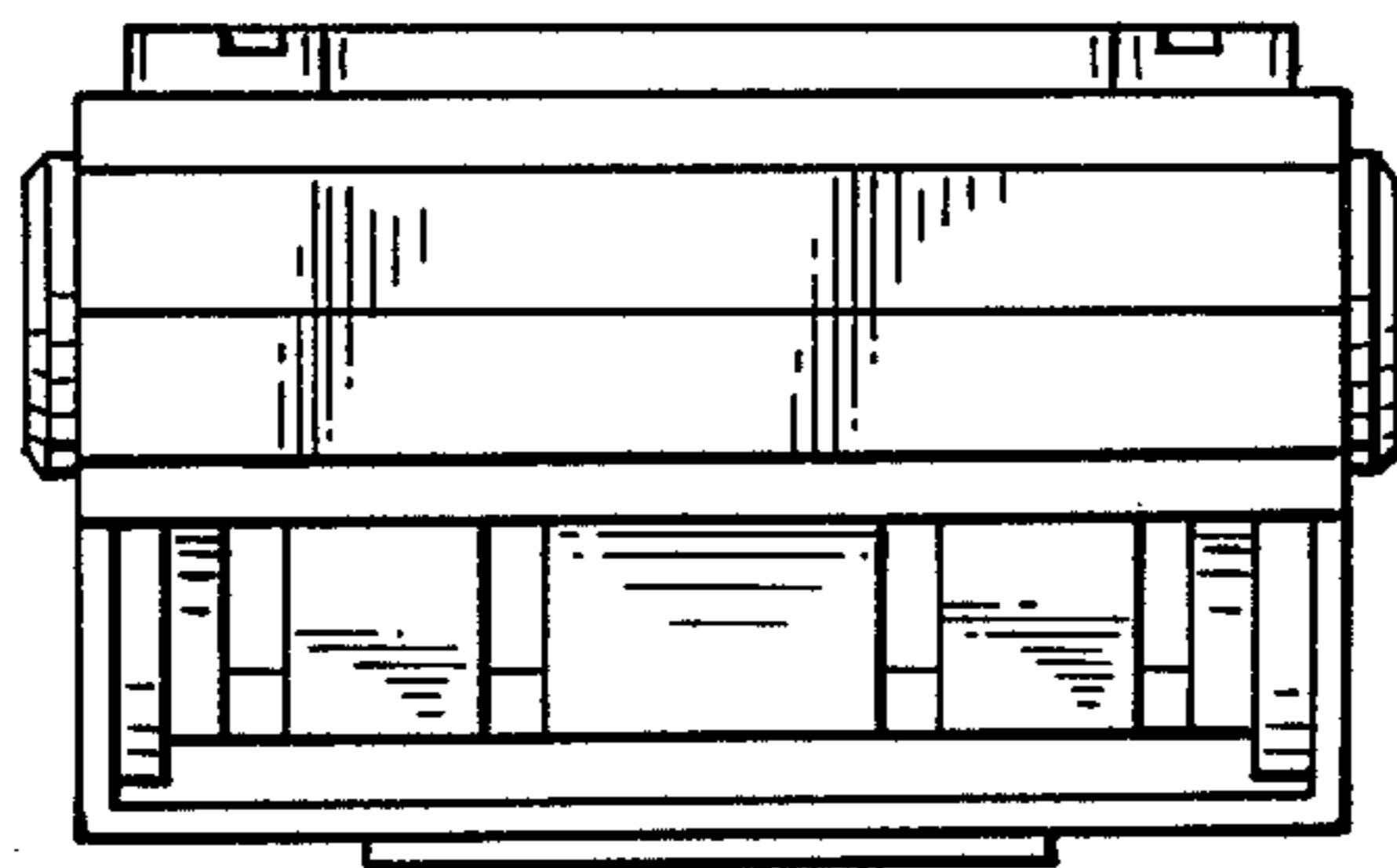

FIG. 6