

[54] **FLUSH MOUNTED LATCH ASSEMBLY**

[75] Inventors: **Richard H. Russell, Farmington; David W. Kaiser, North Haven, both of Conn.**

[73] Assignee: **The Eastern Company, Cleveland, Ohio**

[*] Notice: **The portion of the term of this patent subsequent to Sep. 26, 2003 has been disclaimed.**

[**] Term: **14 Years**

[21] Appl. No.: **72,276**

[22] Filed: **Jul. 10, 1987**

[52] U.S. Cl. **D8/303; D8/300**

[58] Field of Search **D8/300, 302, 306-308, D8/313, 322, 330-331, 336, 338, 346, 350, 353; 70/57, 63, 78, 84, 99, 101**

[56] **References Cited**

U.S. PATENT DOCUMENTS

D. 192,787	5/1962	Dyer	D8/313
D. 196,424	10/1963	Are	D10/8
D. 210,152	2/1968	Pastva	D50/5
D. 210,153	2/1968	Pastva	D50/5
D. 218,672	9/1970	Lauper	D8/109
D. 219,095	11/1970	Allen, Jr.	D8/306
D. 230,945	3/1974	Beckman	D8/341
D. 230,132	1/1974	Pastva	D8/109
D. 265,965	8/1982	Davis et al.	D8/302
D. 270,328	8/1983	Davis et al.	D8/302
D. 271,562	11/1983	Weinerman	D8/338
D. 292,482	10/1987	Weinerman et al.	D8/302
2,317,700	4/1943	Thompson	292/254
2,387,187	10/1945	Smith	70/97
2,594,940	4/1952	Levine	70/66
2,637,585	5/1953	Troche et al.	292/336.3
2,642,300	6/1953	Pelcin	292/173
2,649,322	8/1953	Mack	292/173
2,668,076	2/1954	Troche et al.	292/336.3
2,721,751	10/1955	Holritz	292/169
2,735,706	2/1956	Pelcin	292/34
2,746,784	3/1956	Holritz	292/175
2,763,503	9/1956	Tasch et al.	292/173
2,784,993	3/1957	Collar	292/223
2,840,407	6/1958	Sellon, Jr.	292/169
2,871,048	1/1959	Balogh	292/173
2,900,204	8/1959	Pelcin	292/173

2,987,908	6/1961	Pelcin	70/146
3,044,287	7/1962	Pelcin	70/99
3,044,814	7/1962	Pelcin	292/126
3,055,204	9/1962	Pelcin	70/153
3,081,617	3/1963	McKay	70/153
3,209,563	10/1965	Pelcin	70/146
3,209,564	10/1965	Pelcin	70/148
3,338,610	8/1967	Pelcin et al.	292/126
3,357,734	12/1967	Pastva, Jr.	292/165
3,371,511	3/1968	Atkinson	70/71
3,389,932	6/1968	Pastva, Jr.	292/173
3,449,005	6/1969	Pastva, Jr.	292/173
3,495,862	2/1970	McClintock	292/173
3,576,118	4/1971	Doerrfeld	70/146
3,668,907	6/1972	Pastva, Jr.	70/153
3,707,862	1/1973	Pastva, Jr.	70/150
3,743,336	7/1973	Andrews	292/173
3,758,140	9/1973	Prete, Jr.	292/223
3,782,141	1/1974	Doerrfeld	70/146
3,795,416	3/1974	Hehl et al.	292/336.3
3,841,674	10/1974	Bisbing et al.	292/175
3,850,464	11/1974	Bisbing et al.	292/175
3,857,594	12/1974	Pastva, Jr.	292/27
3,871,198	3/1975	Miller	70/146
4,038,718	8/1977	Reilhac et al.	16/110
4,116,027	9/1978	Tannery	70/472
4,131,002	12/1978	Gianelo	70/84
4,134,281	1/1979	Pelcin	70/208
4,138,869	2/1979	Pelcin	70/151
4,170,119	10/1979	Kalis, Jr.	70/221
4,177,656	12/1979	Davis	70/84
4,231,597	11/1980	Pelcin	292/164
4,309,884	1/1982	Davis	70/472
4,312,202	1/1982	Pastva, Jr. et al.	70/472
4,312,203	1/1982	Davis	70/472
4,312,204	1/1982	Davis	70/472
4,312,205	1/1982	Reed et al.	70/472
4,320,642	3/1982	Pastva, Jr.	70/472
4,321,812	3/1982	Pelcin	70/472
4,335,595	6/1982	Swan et al.	70/149
4,370,874	2/1983	Munn	70/204
4,413,849	11/1983	Davis et al.	292/229
4,420,954	12/1983	Hieronymi et al.	70/150
4,438,964	3/1984	Peters	292/216
4,465,328	8/1984	Tihanyi et al.	312/215
4,492,394	1/1985	Dignan	292/64
4,578,968	4/1986	Messier, Jr.	70/208
4,671,547	6/1987	Weinerman et al.	292/197
4,679,835	7/1987	Weinerman et al.	292/197
4,683,736	8/1987	Weinerman et al.	70/208
4,706,478	11/1987	Swan et al.	70/208

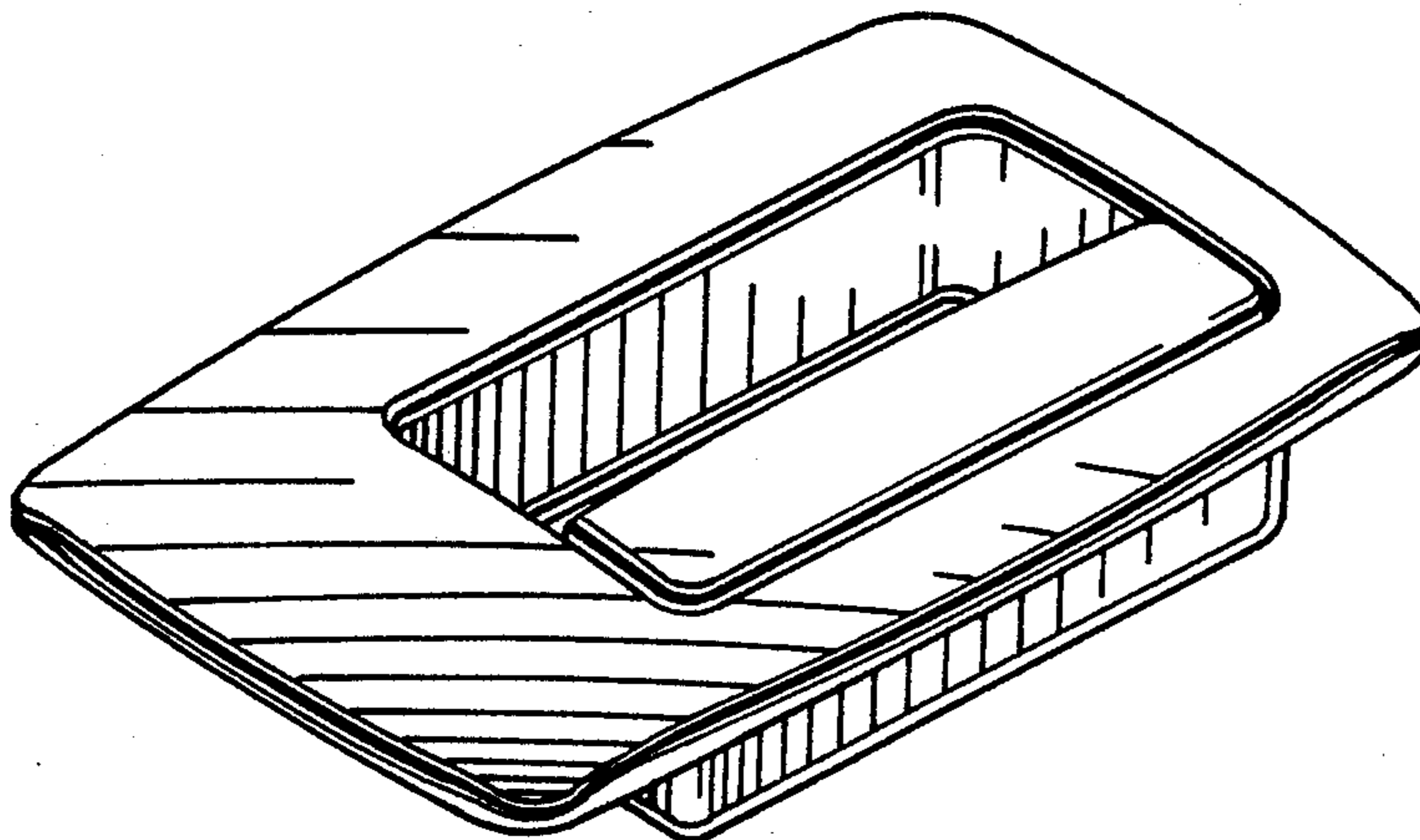

OTHER PUBLICATIONS

Sweets Catalogue File (1981), Section 8.1-AM, p. 12, Amarlite Door Mid-Panel Latch.

Eberhard Catalogue No. 103, ©1985, Section 1, p. 102, Latch, top left corner of page.

Eberhard Catalogue No. 103, ©1985, Section 1, p. 102, Latch, lower left corner of page.

Eberhard Catalogue No. 103, ©1985, Section 1, p. 28, Single Point Squeeze Latch.

Southco Inc., *Southco Fasteners Handbook 37*, Concordville, PA 19331, date unknown.

Eberhard Manufacturing Co., *Handbook of Latches, Locks, Hinges, Handles, and Related Hardware*, No. 103, Cleveland, OH 44136, 1985.

Adams Rite Manufacturing Co., *Hardware for Glass Doors That Swing or Slide*, City of Industry, CA 91749, Jan. 1988.

Primary Examiner—Wallace R. Burke

Assistant Examiner—Brian N. Vinson

Attorney, Agent, or Firm—David A. Burge

[57]

CLAIM

The ornamental design for a flush mounted latch assembly, as shown and described.

DESCRIPTION

FIG. 1 is a front perspective view of a flush mounted latch assembly showing our new design;

FIG. 2 is a front elevational view thereof;

FIG. 3 is a rear elevational view thereof;

FIG. 4 is a bottom plan view thereof;

FIG. 5 is a top plan view thereof;

FIG. 6 is a right side elevational view thereof;

FIG. 7 is a left side elevational view thereof;

FIG. 8 is a vertical cross-sectional view thereof, taken along line 8—8 of FIG. 2;

FIG. 9 is a vertical cross-sectional view thereof, taken along line 9—9 of FIG. 3;

FIG. 10 is a rear perspective view thereof;

FIG. 11 is a rear, fragmentary perspective view thereof, with portions omitted for clarity of illustration;

FIG. 12 is a top perspective view of a second embodiment thereof;

FIG. 13 is a front elevational view of the embodiment of FIG. 12;

FIG. 14 is a rear elevational view of the embodiment of FIG. 12;

FIG. 15 is a bottom plan view of the embodiment of FIG. 12;

FIG. 16 is a top plan view of the embodiment of FIG. 12;

FIG. 17 is a right side elevational view of the embodiment of FIG. 12;

FIG. 18 is a left side elevational view of the embodiment of FIG. 12;

FIG. 19 is a vertical cross-sectional view of the embodiment of FIG. 12 taken along line 19—19 of FIG. 13;

FIG. 20 is a vertical cross-sectional view of the embodiment of FIG. 12 taken along line 20—20 of FIG. 14;

FIG. 21 is a rear perspective view of the embodiment of FIG. 12;

FIG. 22 is a rear, fragmentary perspective view of the embodiment of FIG. 12 with portions omitted for clarity of illustration;

FIG. 23 is a top perspective view of a third embodiment thereof;

FIG. 24 is a front elevational view of the embodiment of FIG. 23;

FIG. 25 is a front view of a fourth embodiment thereof, the only difference from the embodiment of FIG. 12 residing in the inclusion of a plugged aperture;

FIG. 26 is a rear elevational view of the embodiment of FIG. 25;

FIG. 27 is a front elevational view of a fifth embodiment thereof, the only difference from the embodiment of FIG. 25 residing in the inclusion of an operator element having a hex tool receiving aperture;

FIG. 28 is a front elevational view of a sixth embodiment thereof, the only difference from the embodiment of FIG. 25 residing in the inclusion of an operator element having a screwdriver blade receiving aperture; and

FIG. 29 is a front elevational view of a seventh embodiment thereof, the only difference from the embodiment of FIG. 25 residing in the inclusion of an operator element having a key receiving aperture.

The broken line showing in FIGS. 11, 13-22 and 26 of mounting elements that extend rearwardly from the housing is for illustrative purposes only and forms no part of the claimed.

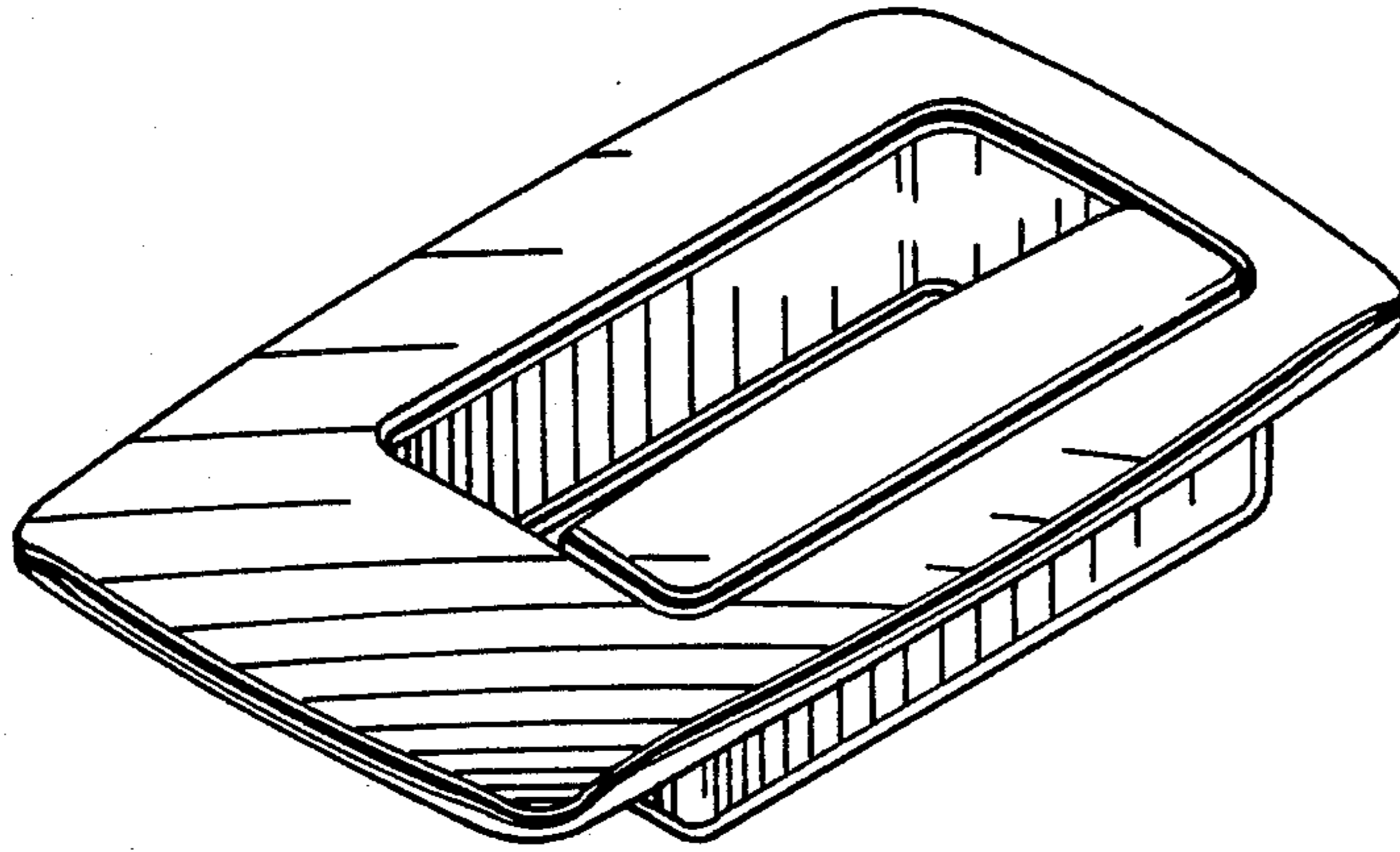
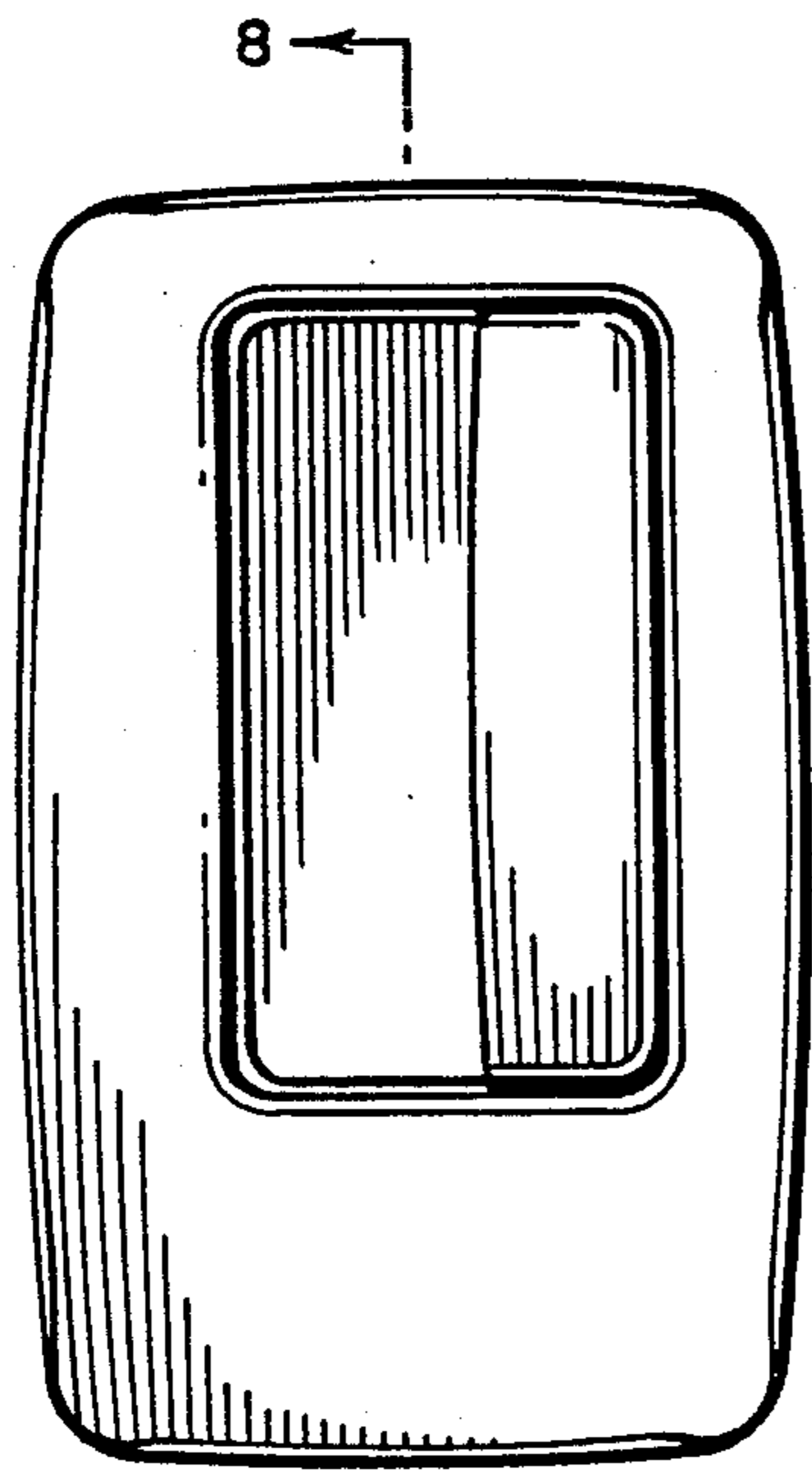
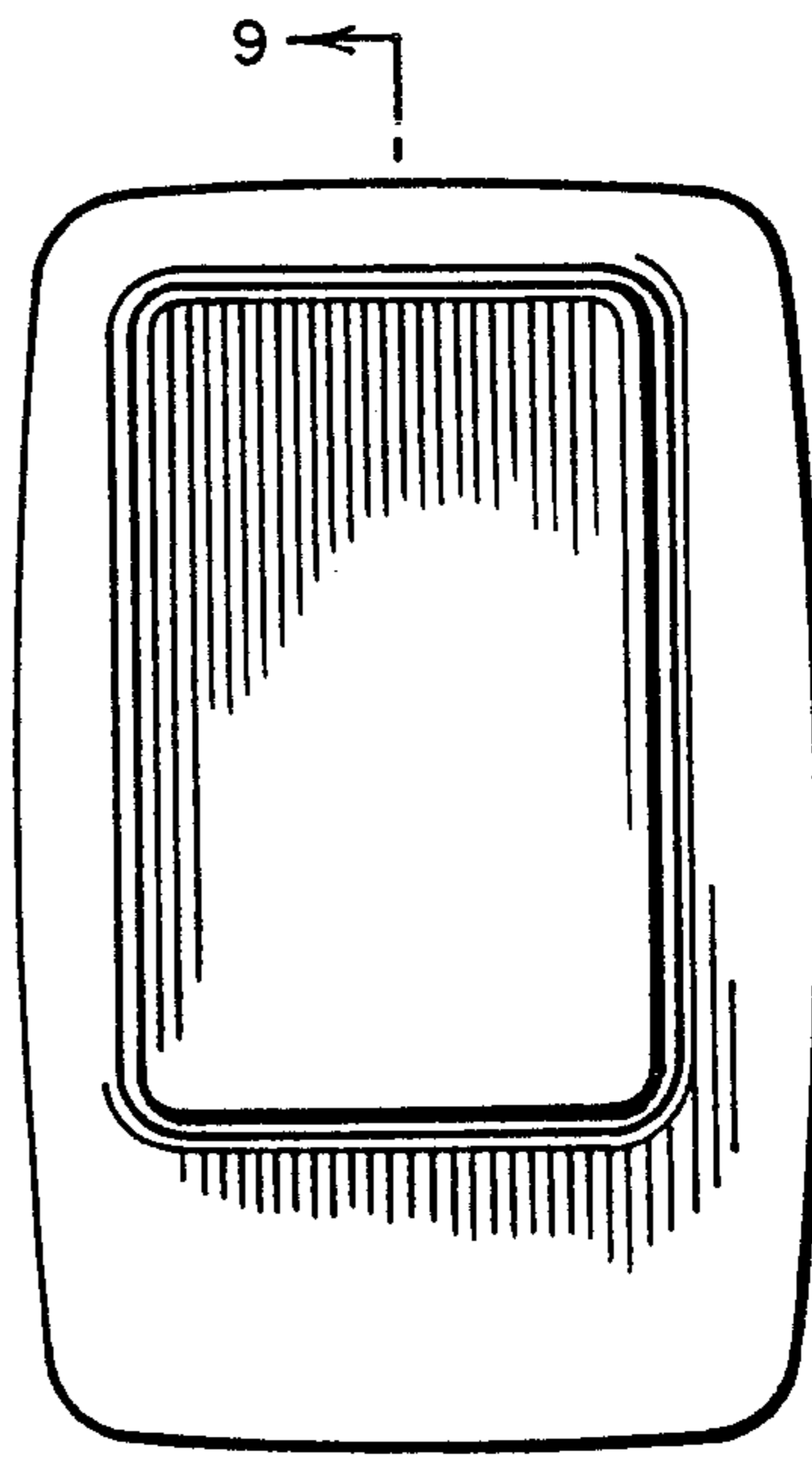

FIG. 1



8
FIG. 2



9
FIG. 3



FIG. 4



FIG. 5

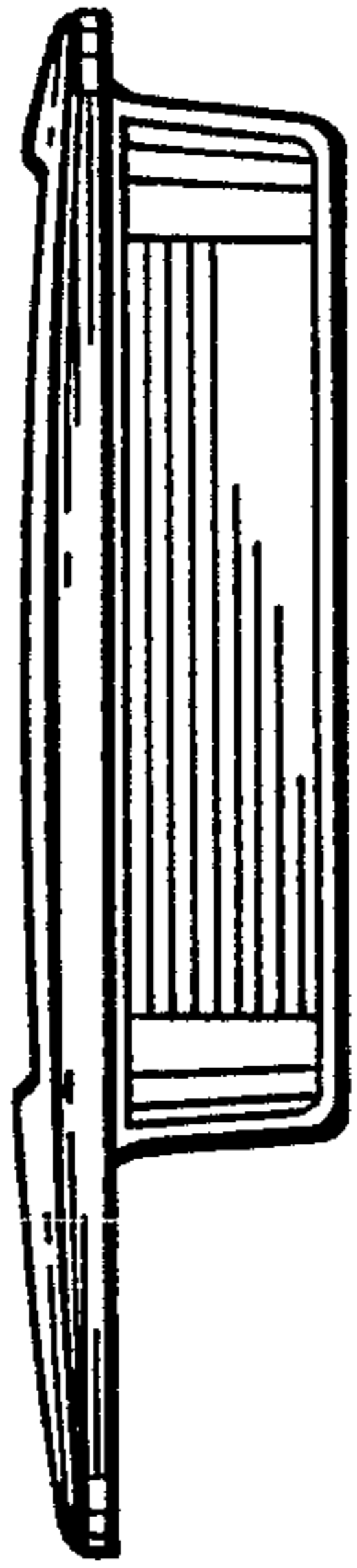

FIG. 6



FIG. 7

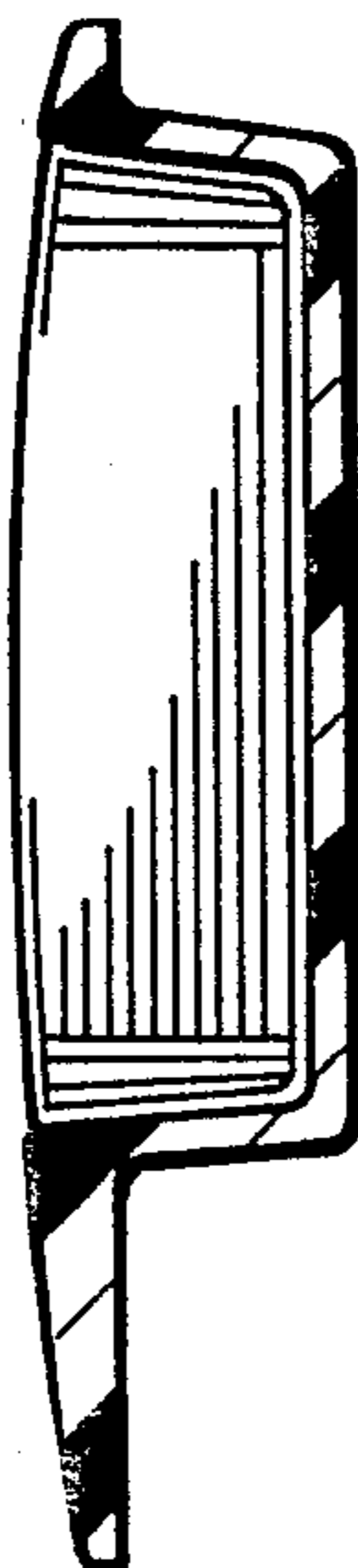

FIG. 8

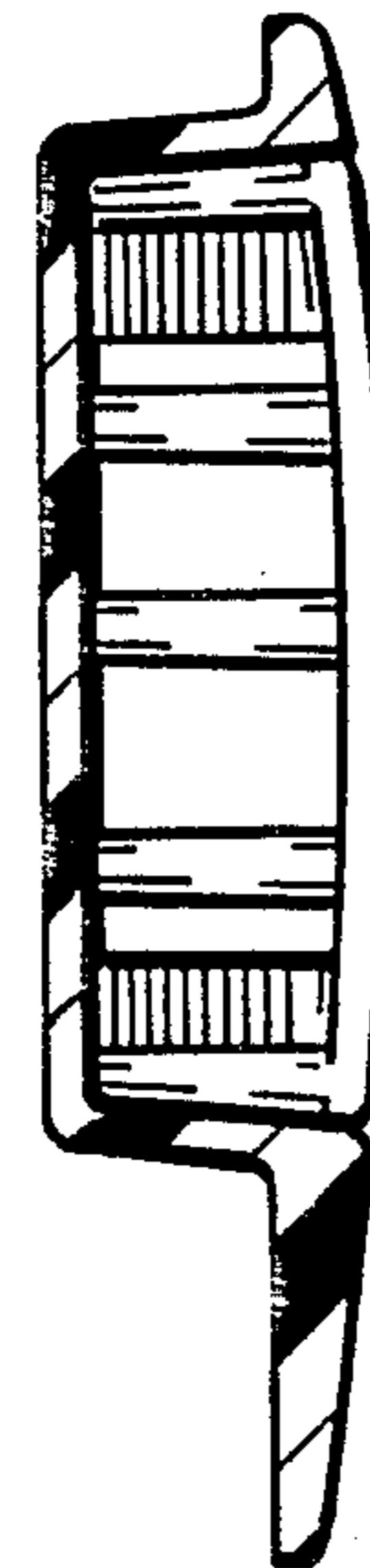

FIG. 9

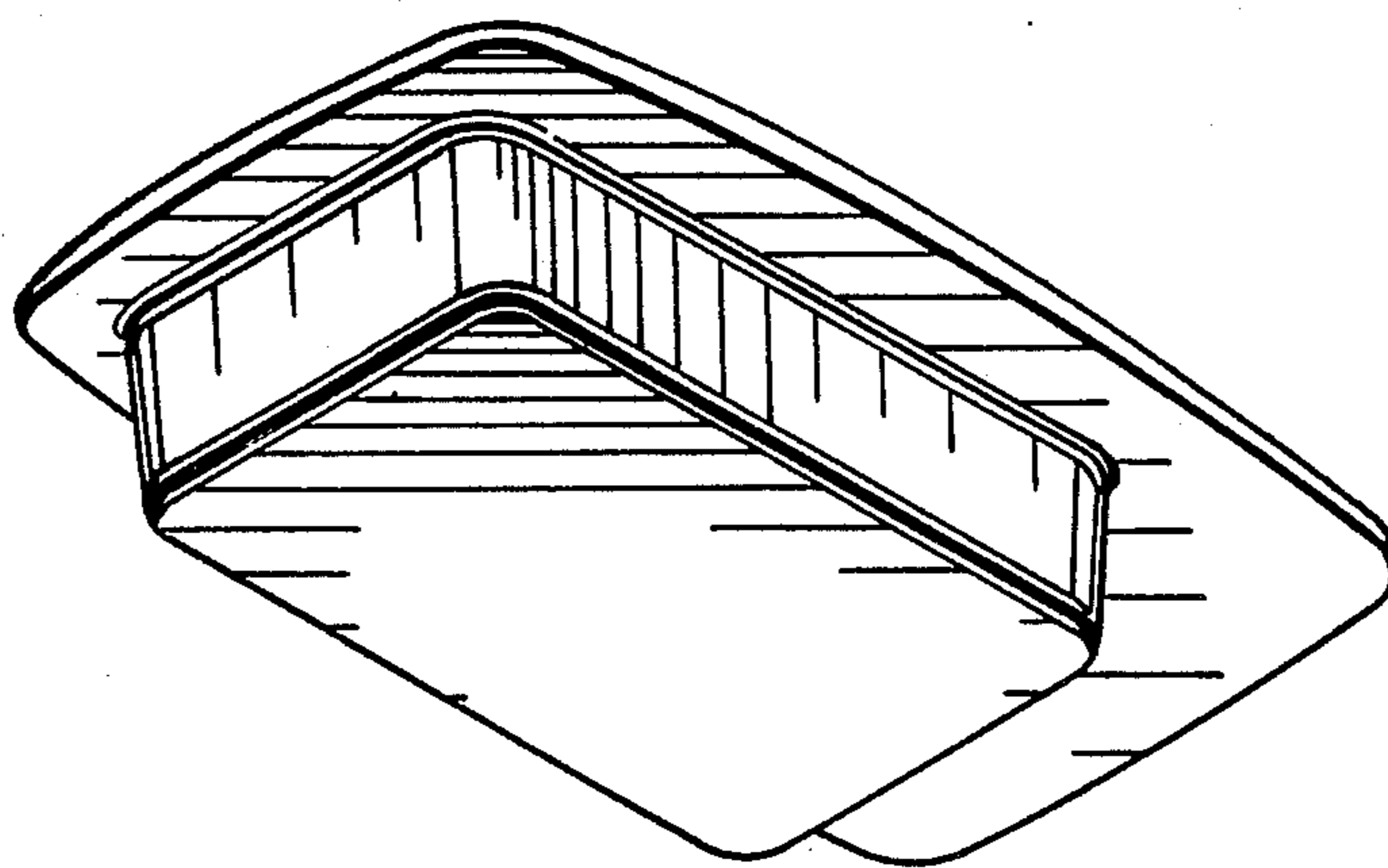

FIG. 10

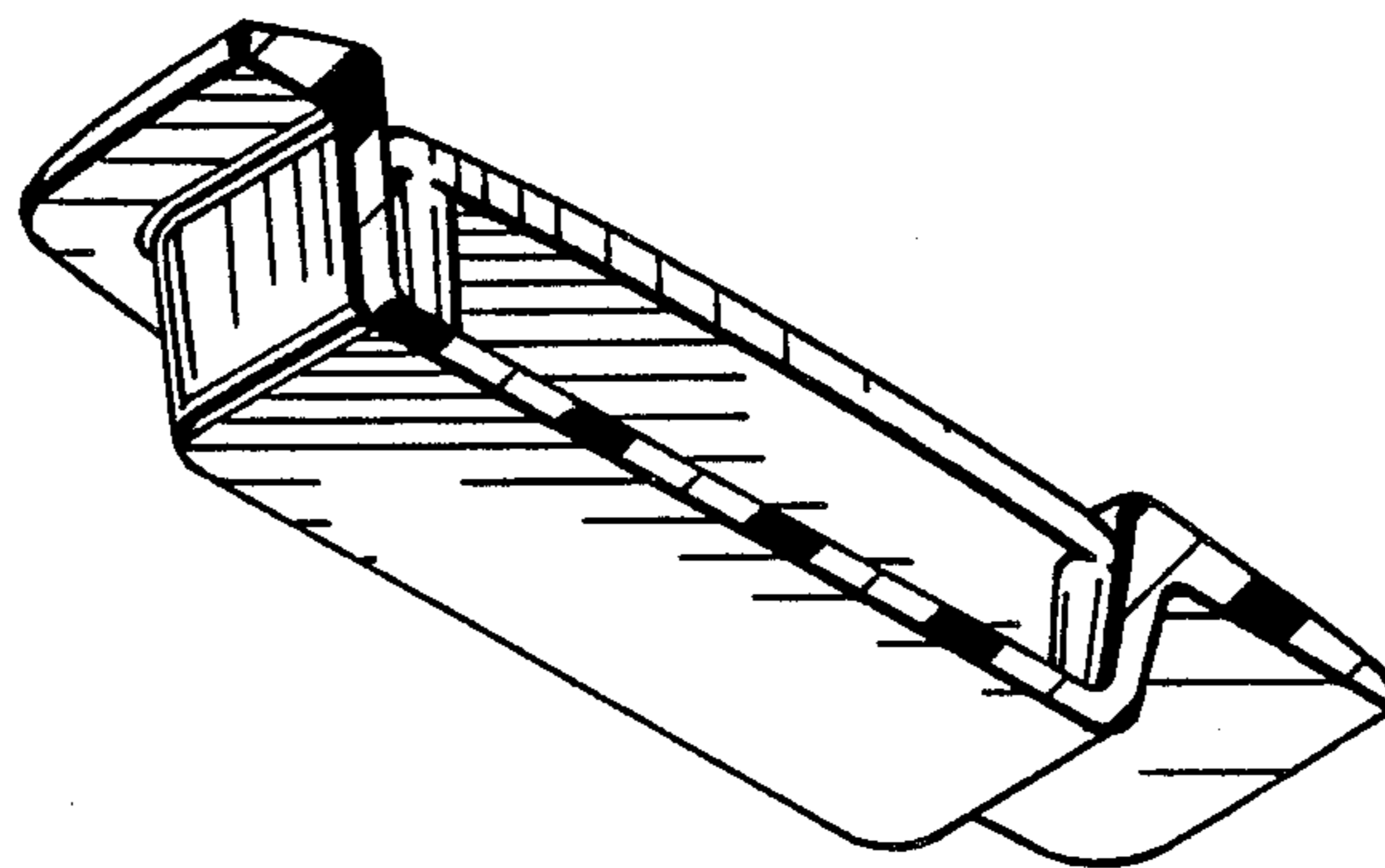

FIG. 11

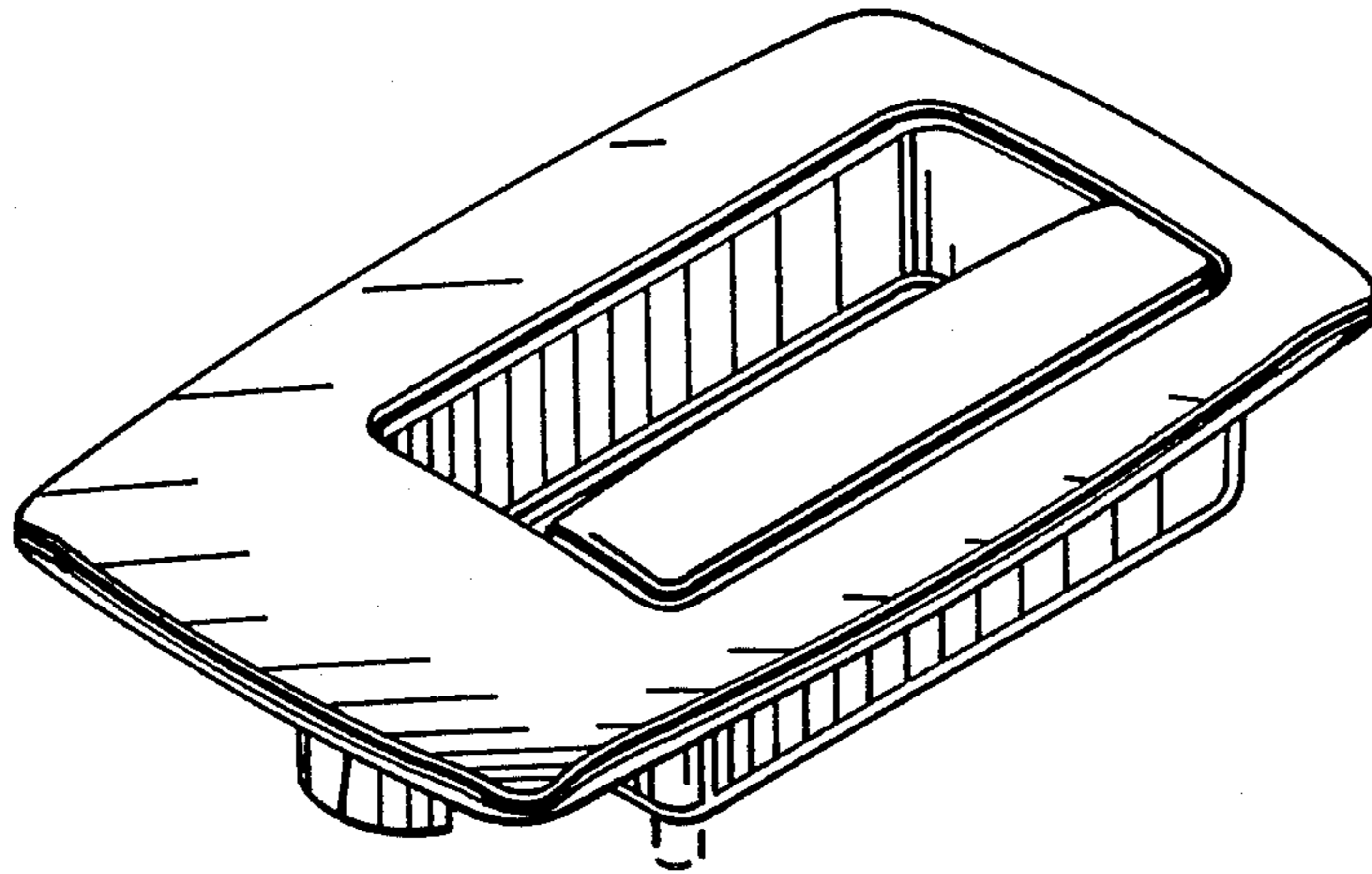

FIG. 12

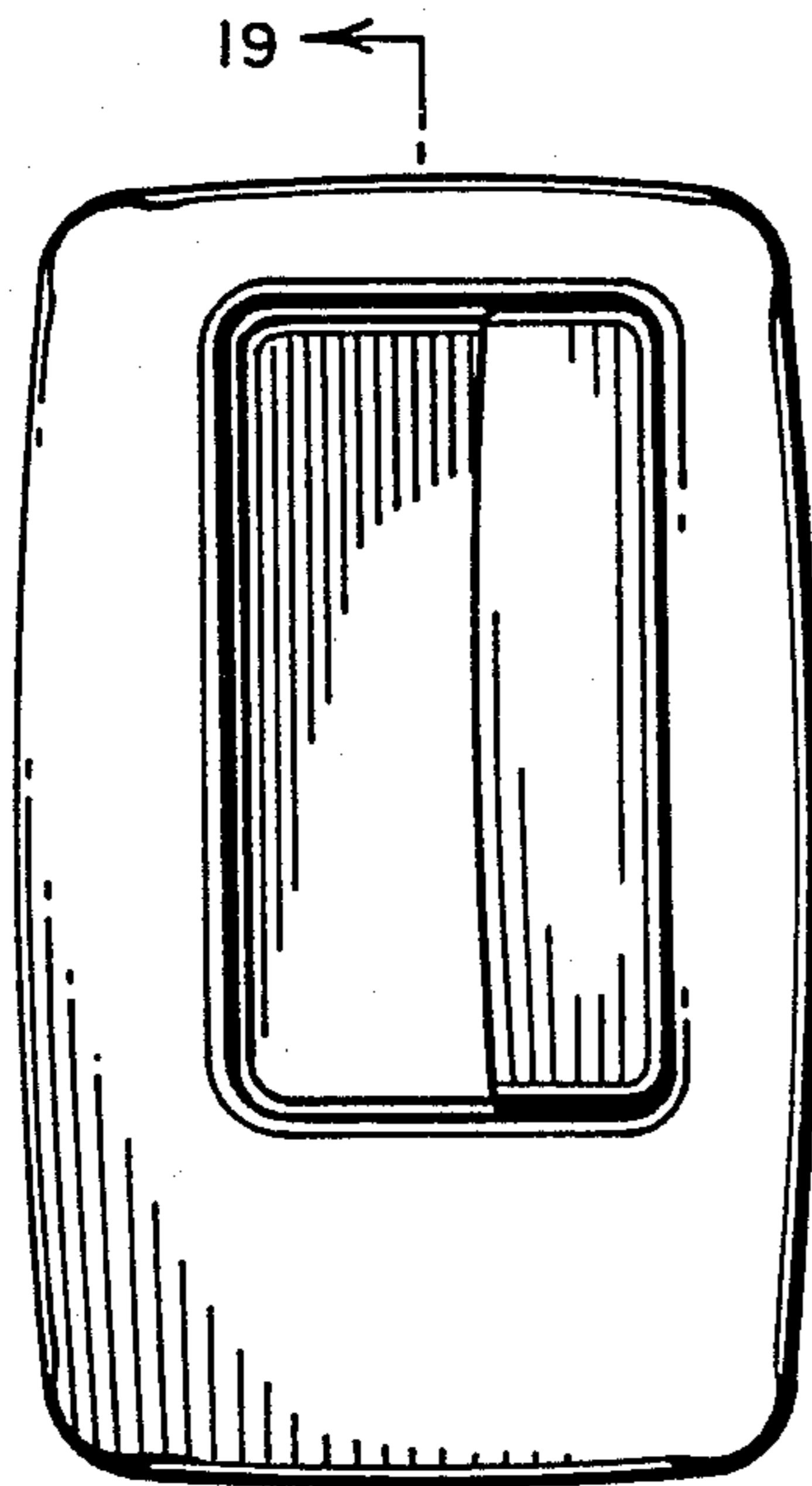

FIG. 13

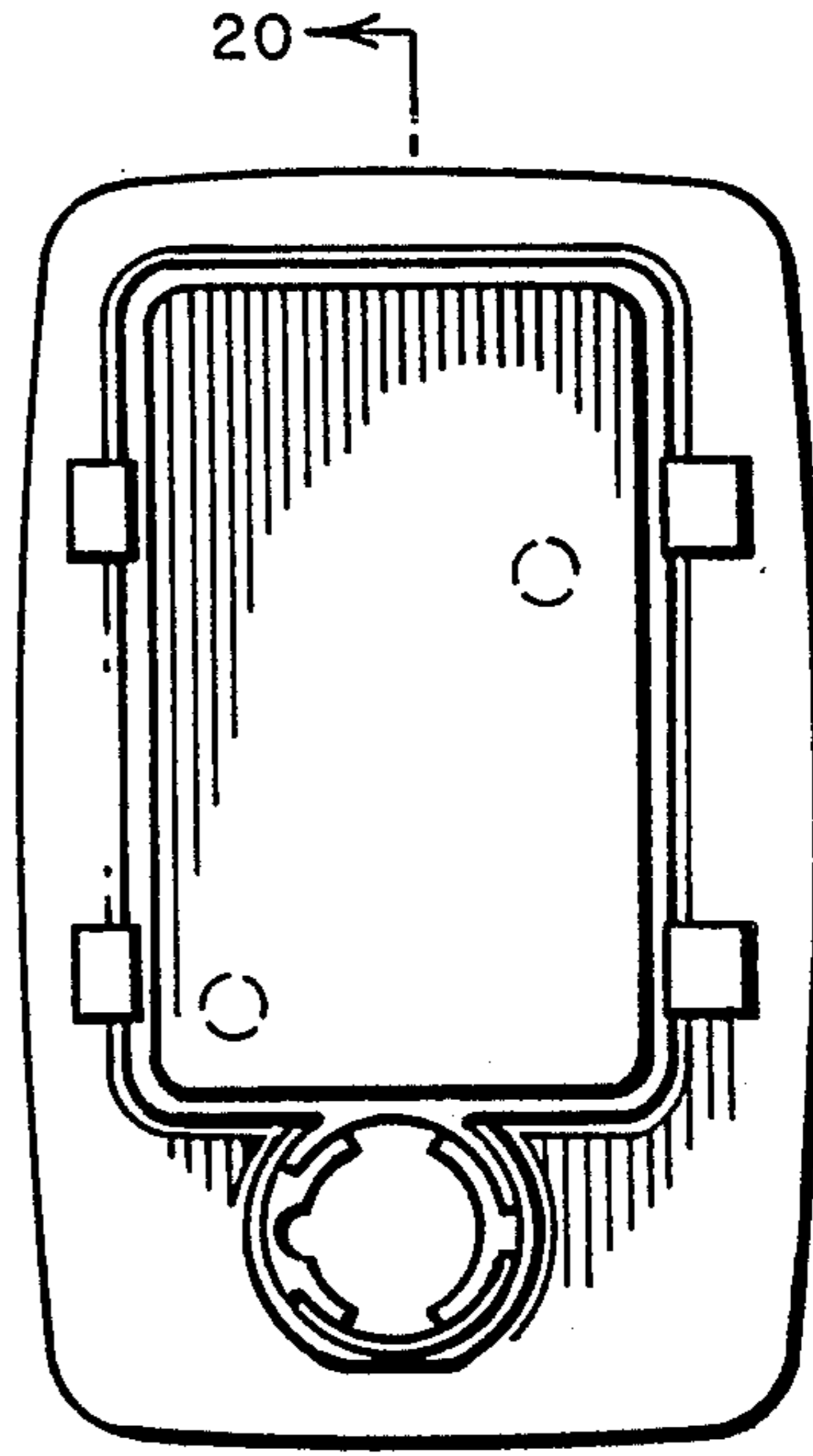

FIG. 14

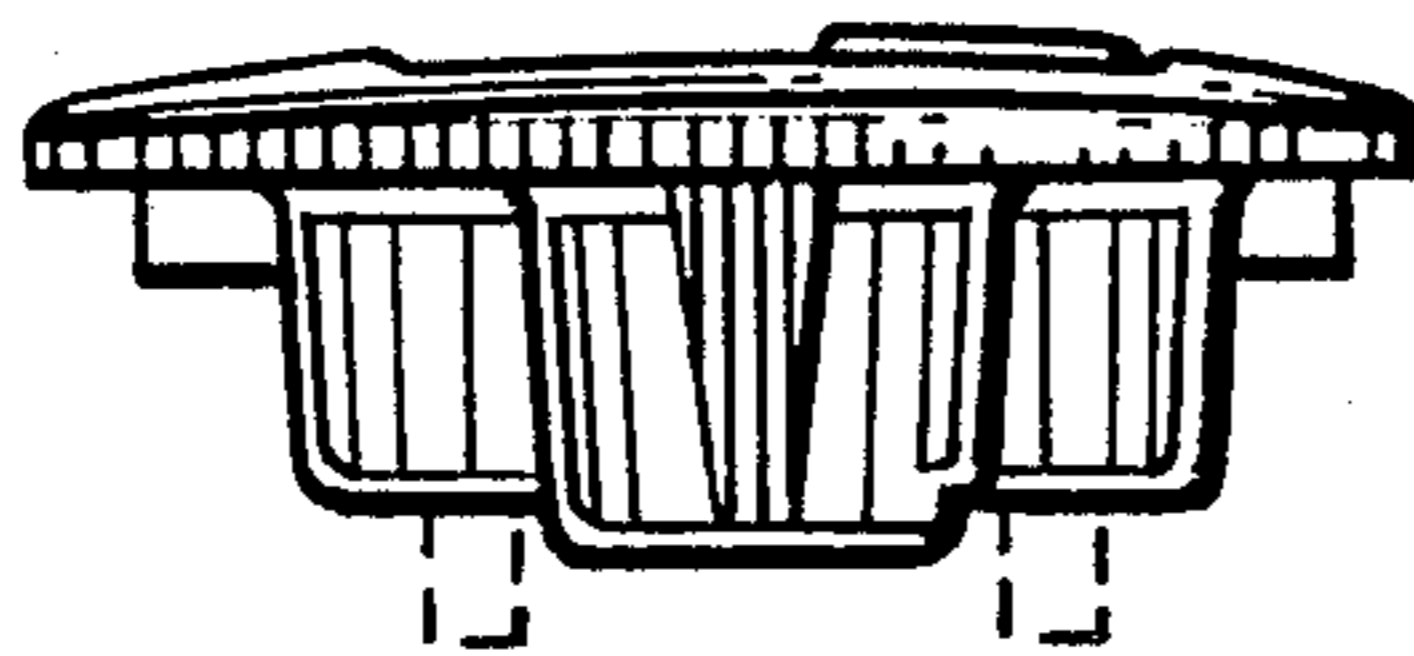

FIG. 15

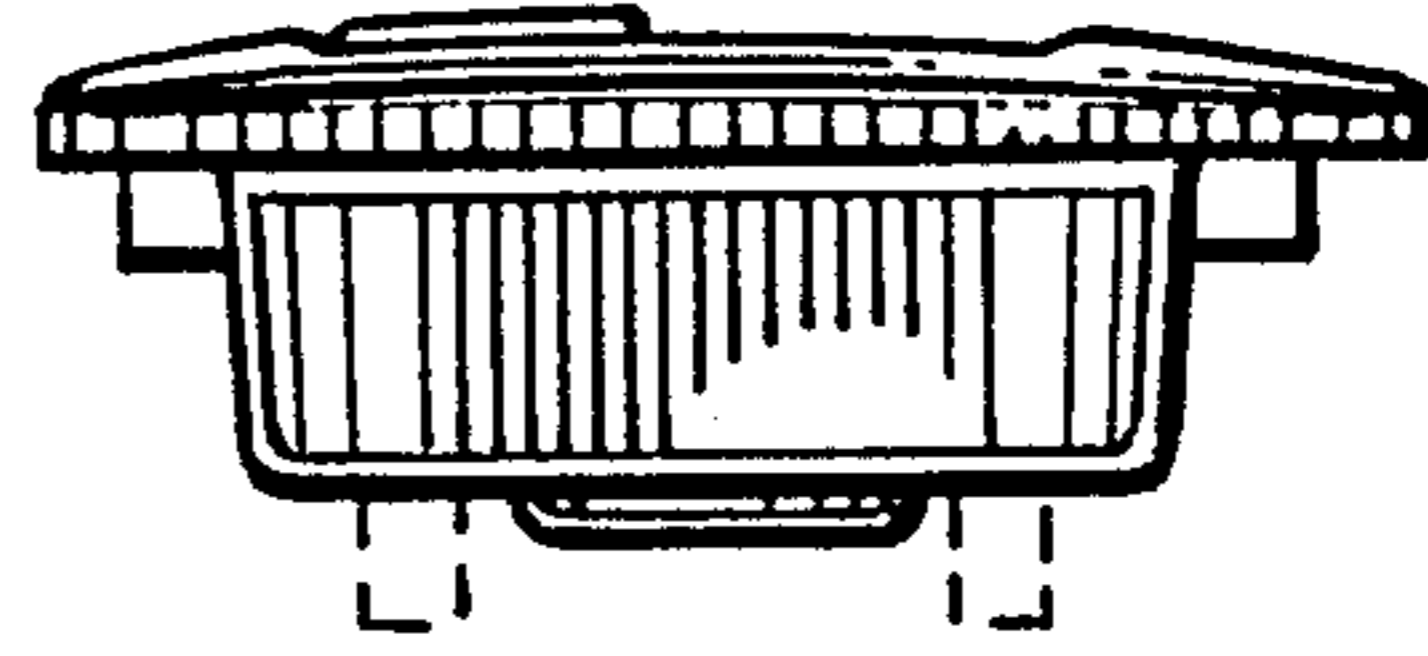

FIG. 16

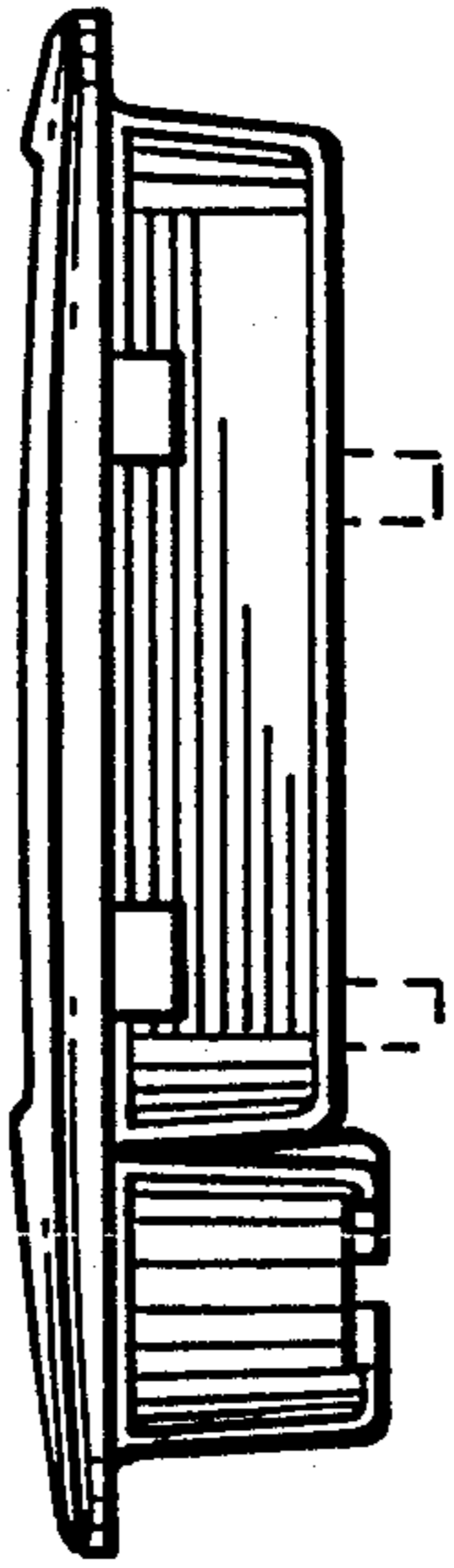

FIG. 17

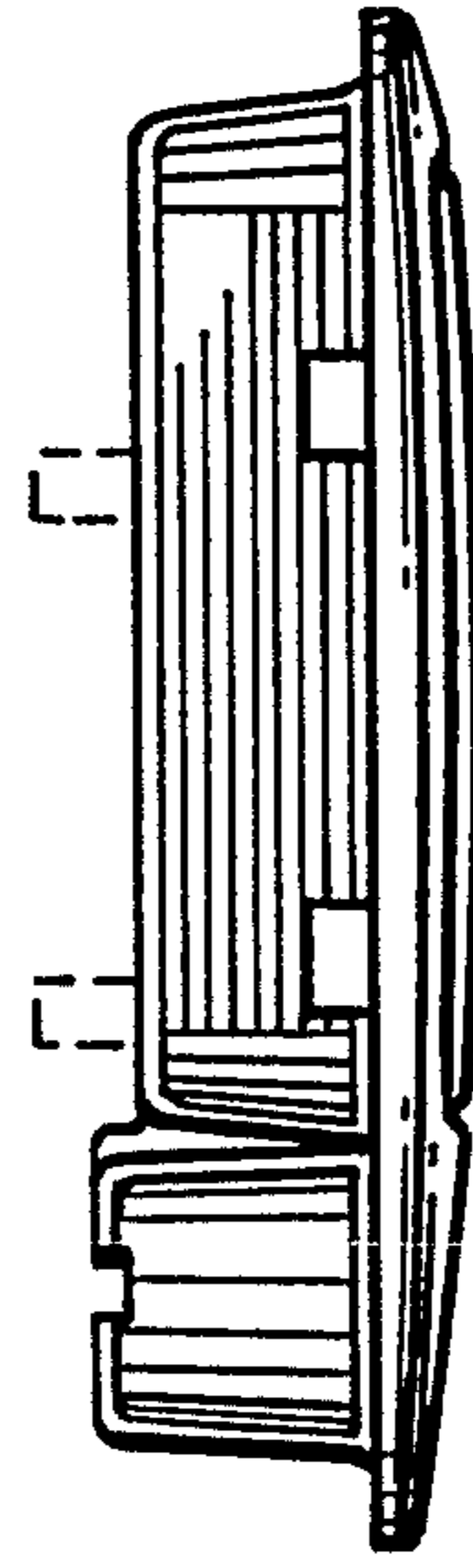

FIG. 18

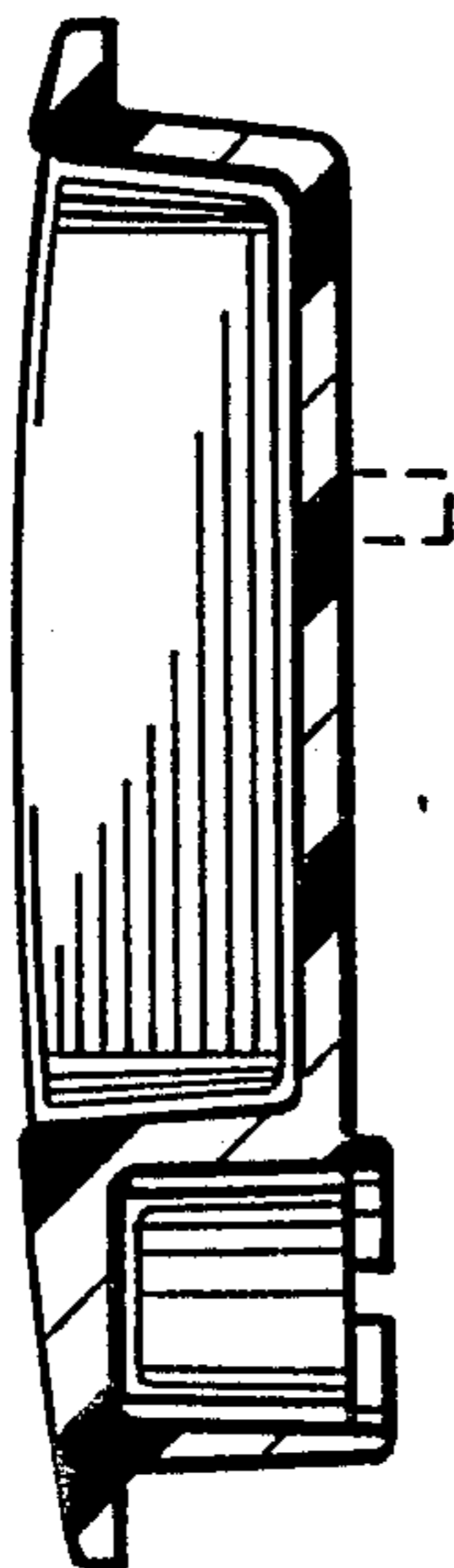

FIG. 19

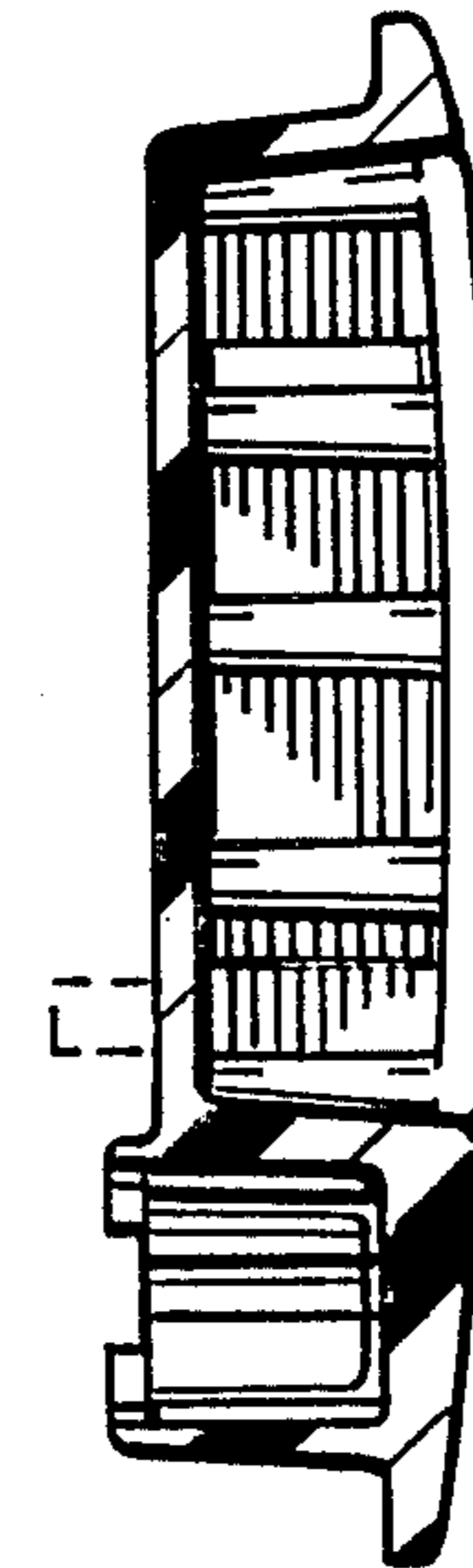

FIG. 20

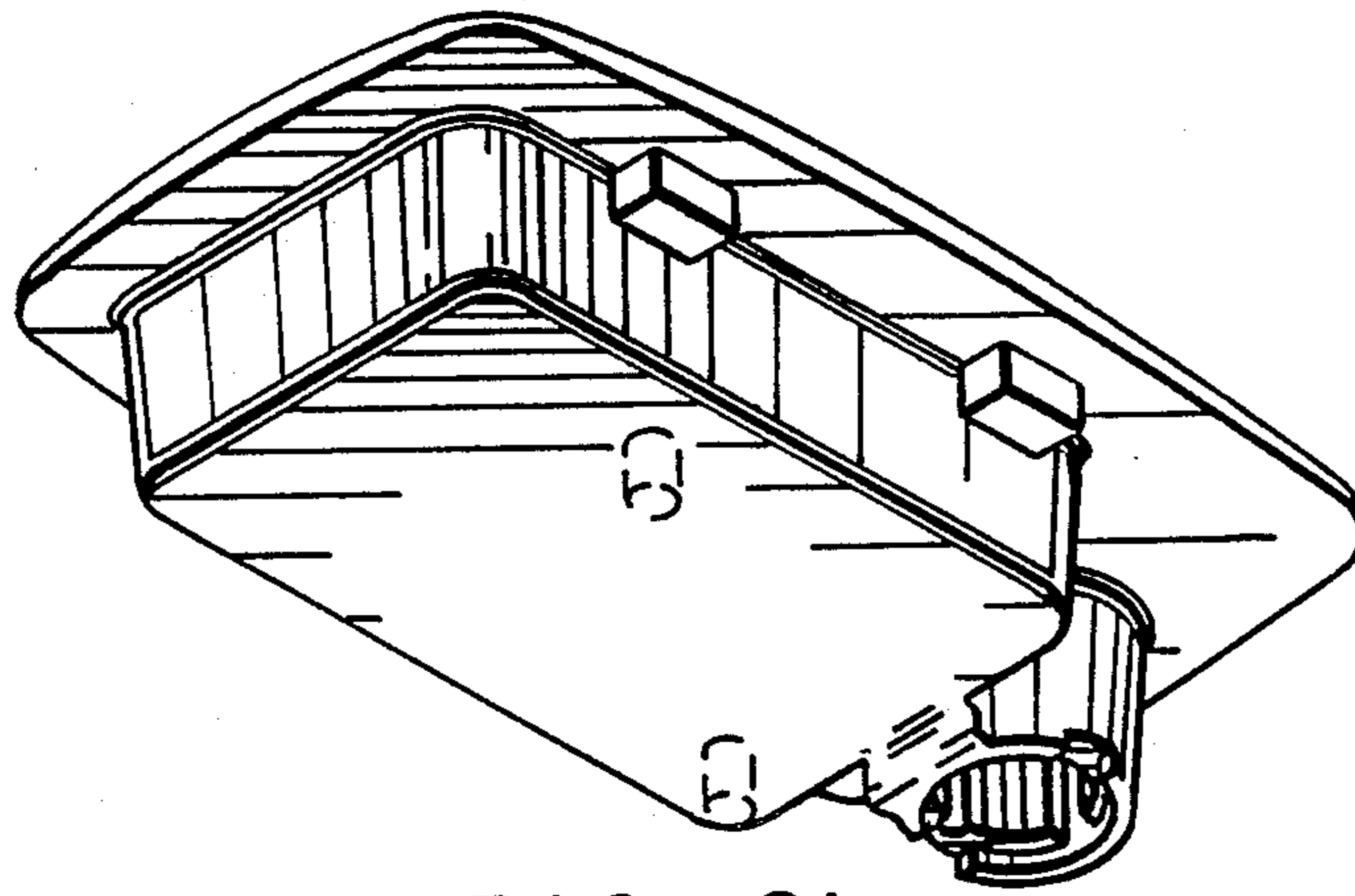

FIG. 21

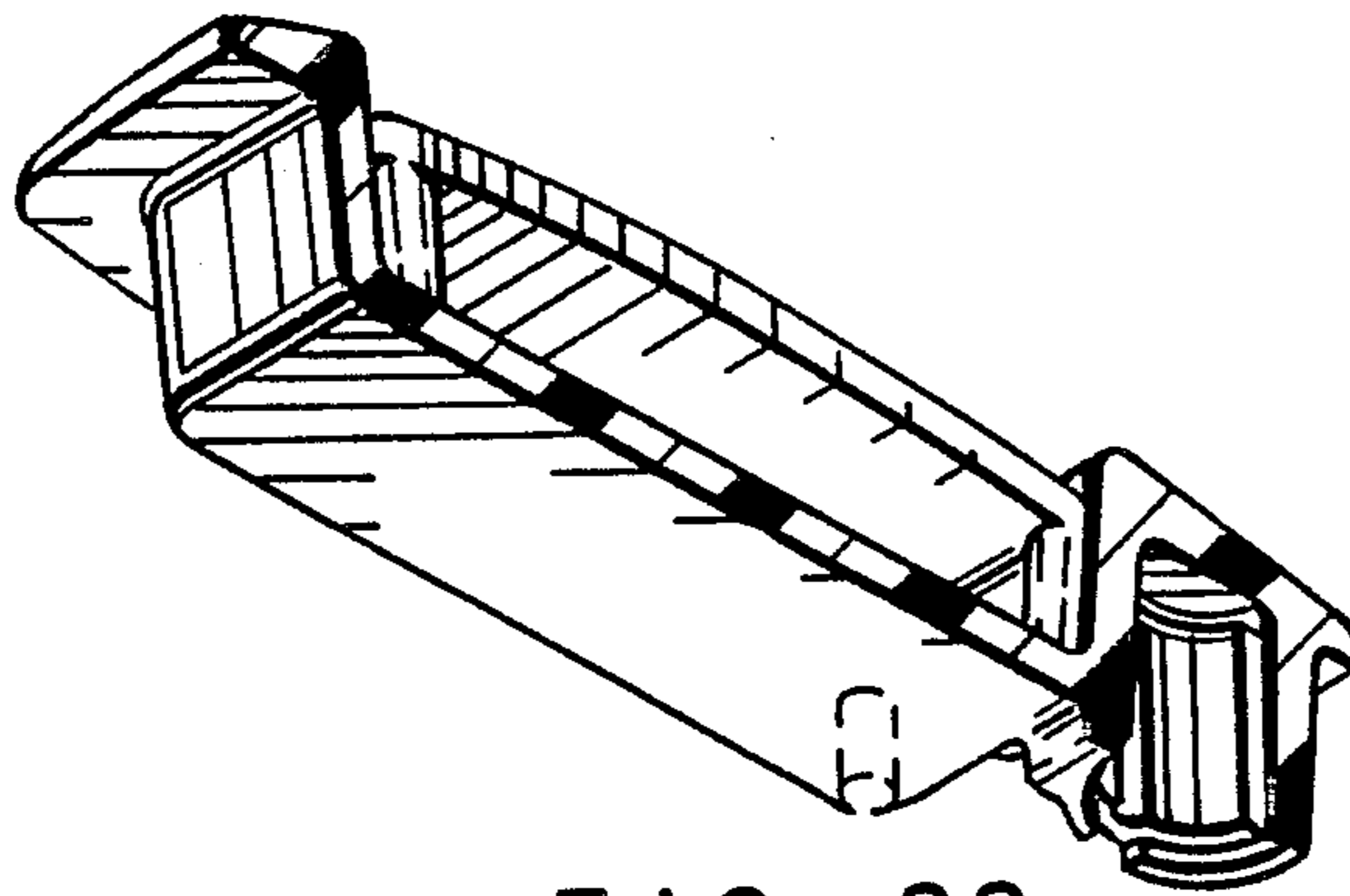

FIG. 22

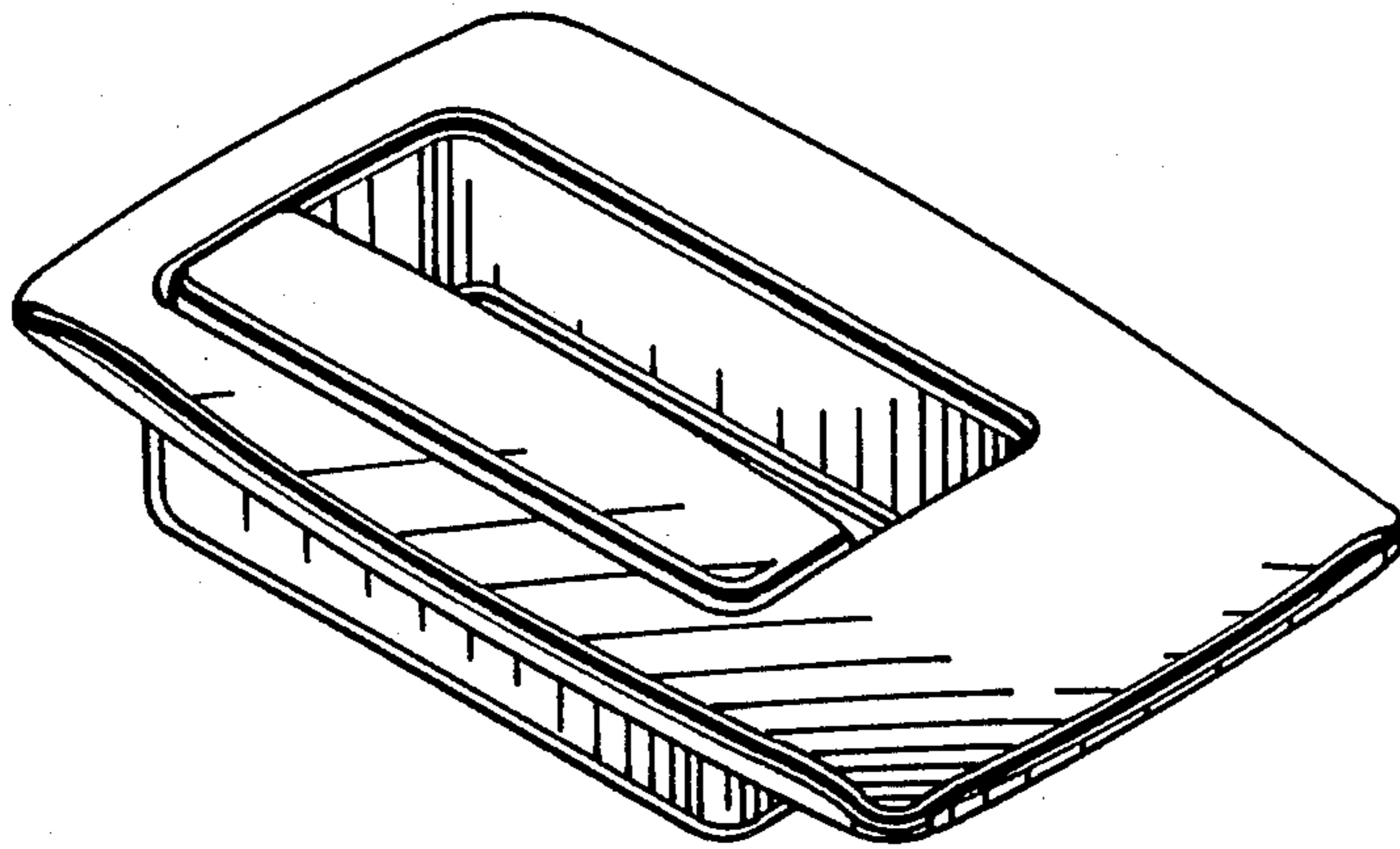

FIG. 23

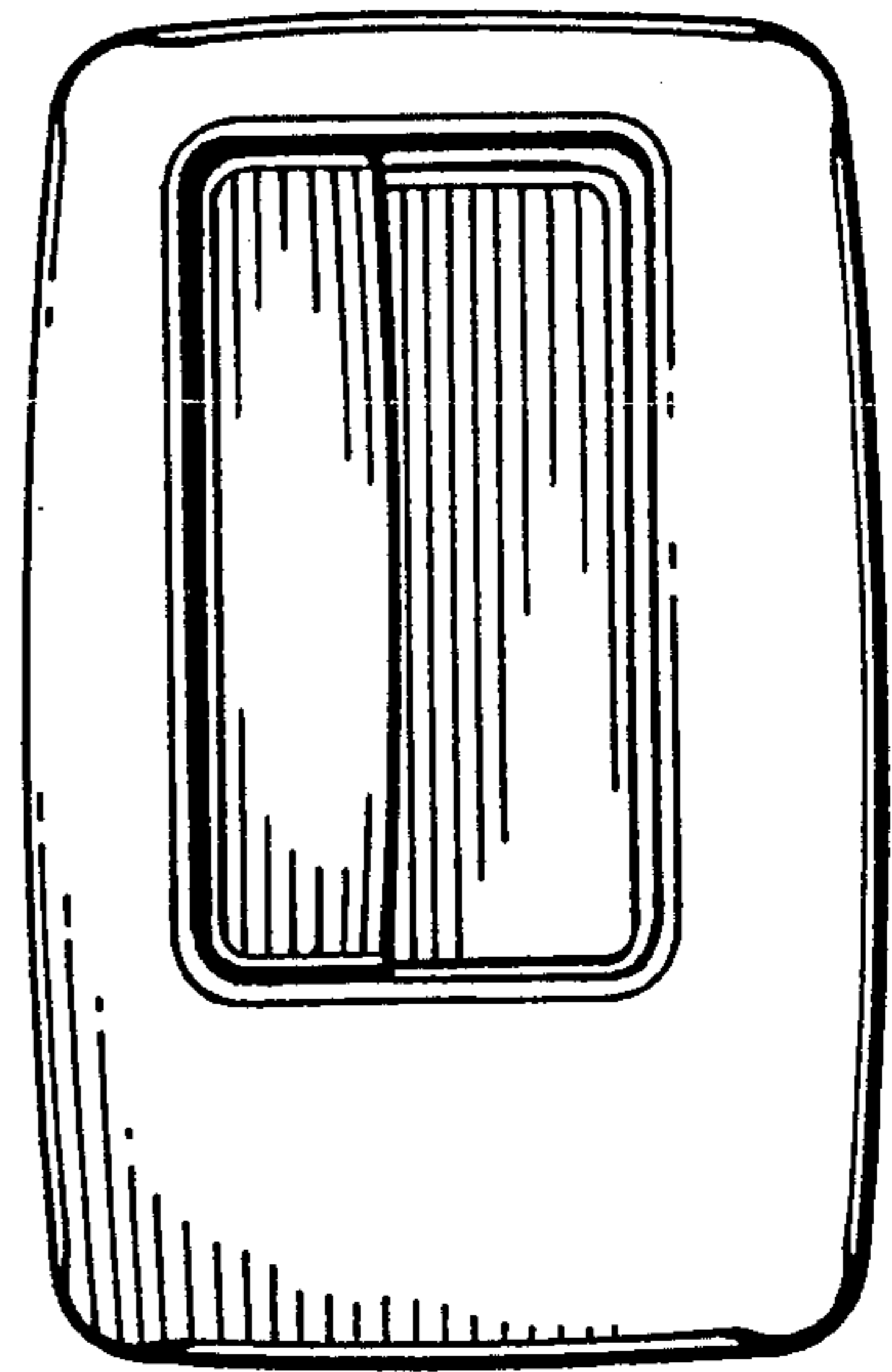

FIG. 24

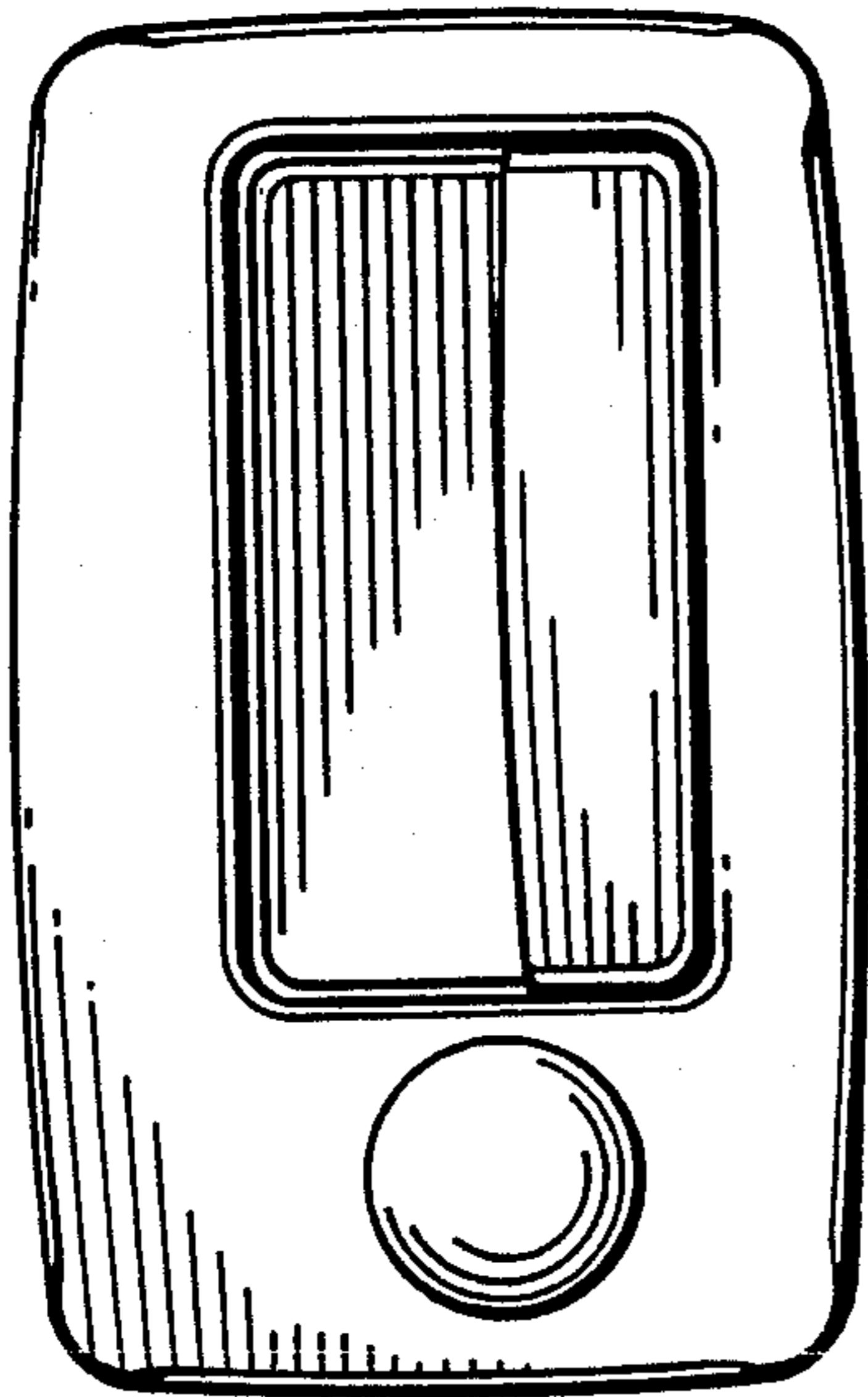

FIG. 25

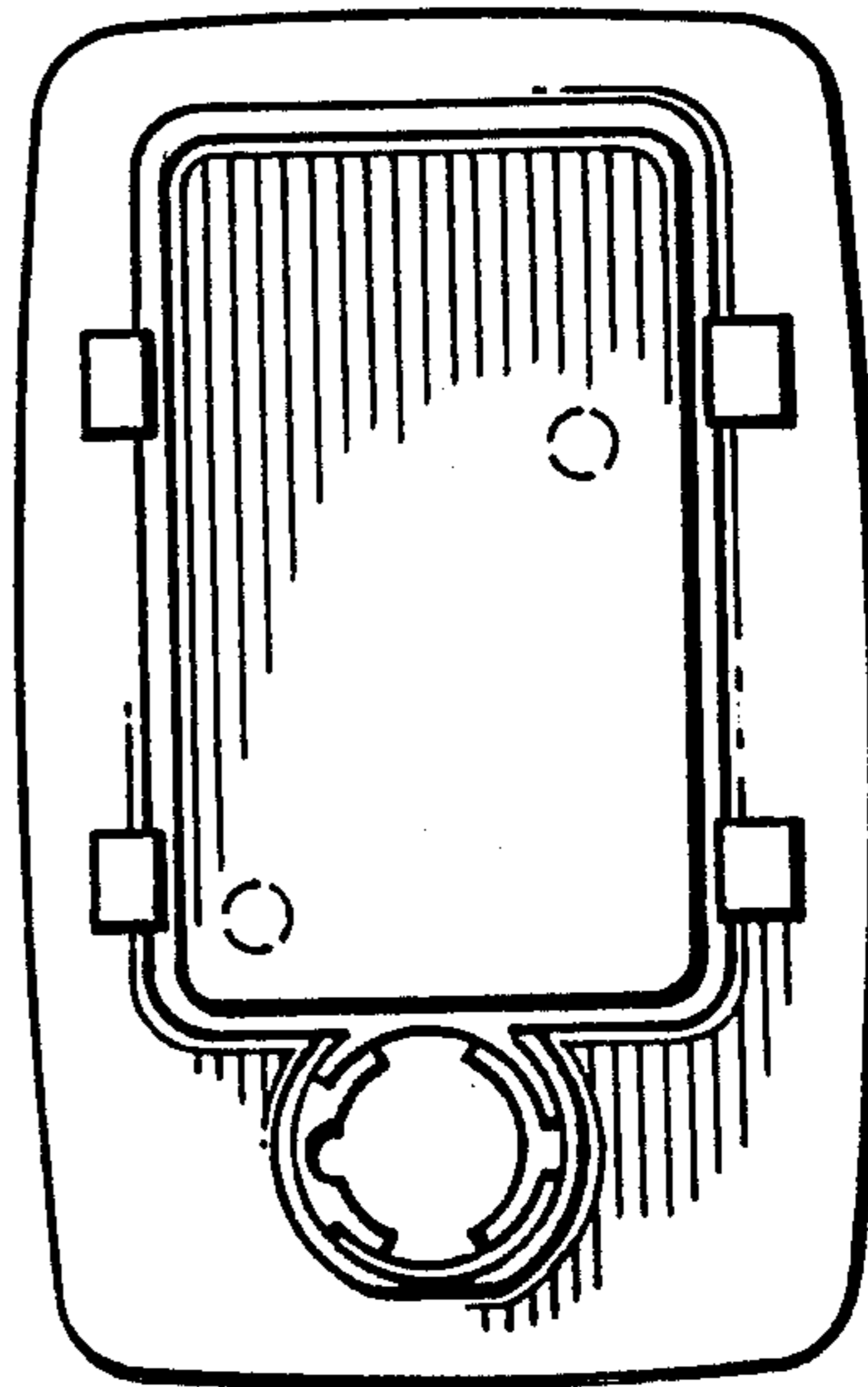

FIG. 26

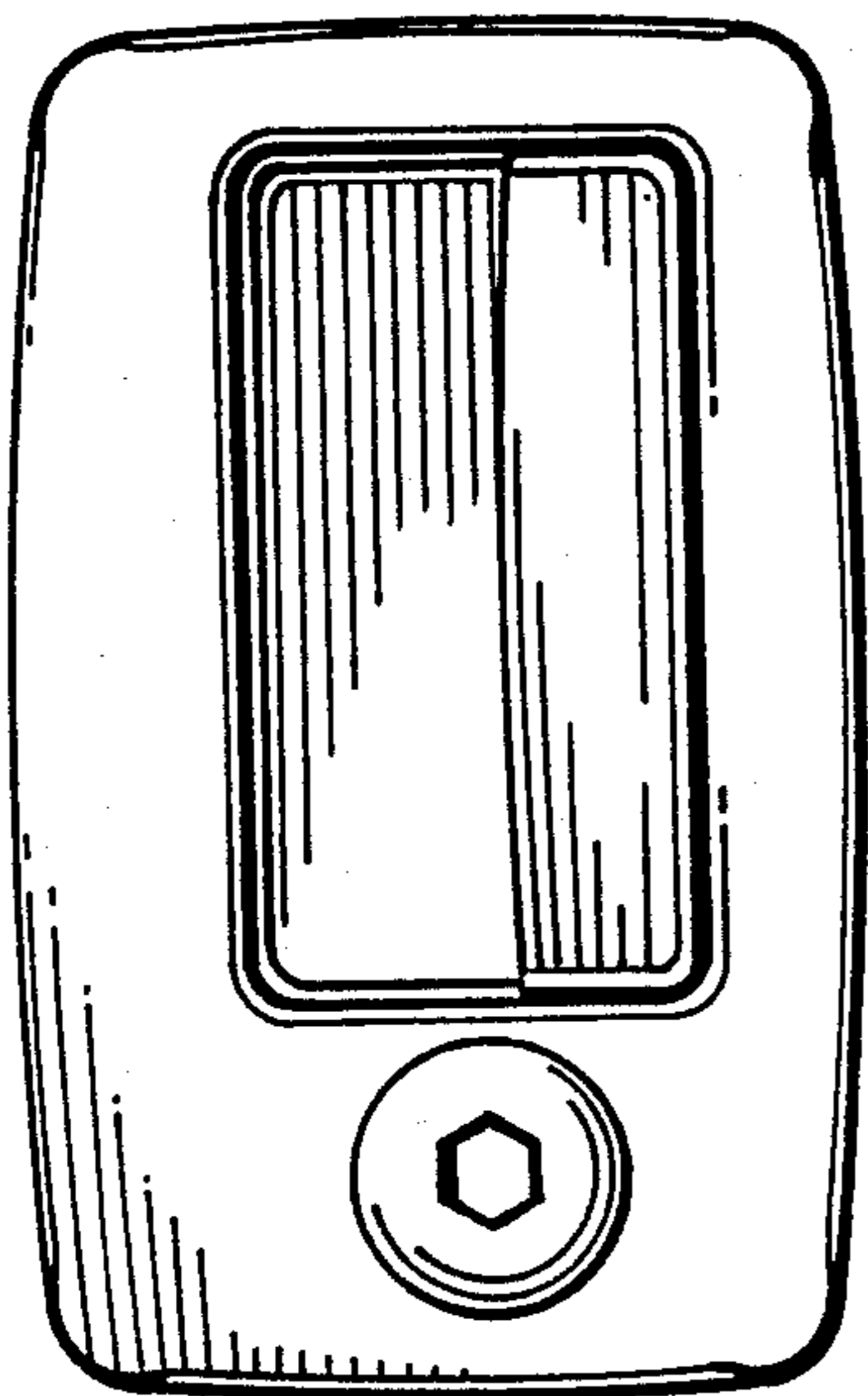

FIG. 27

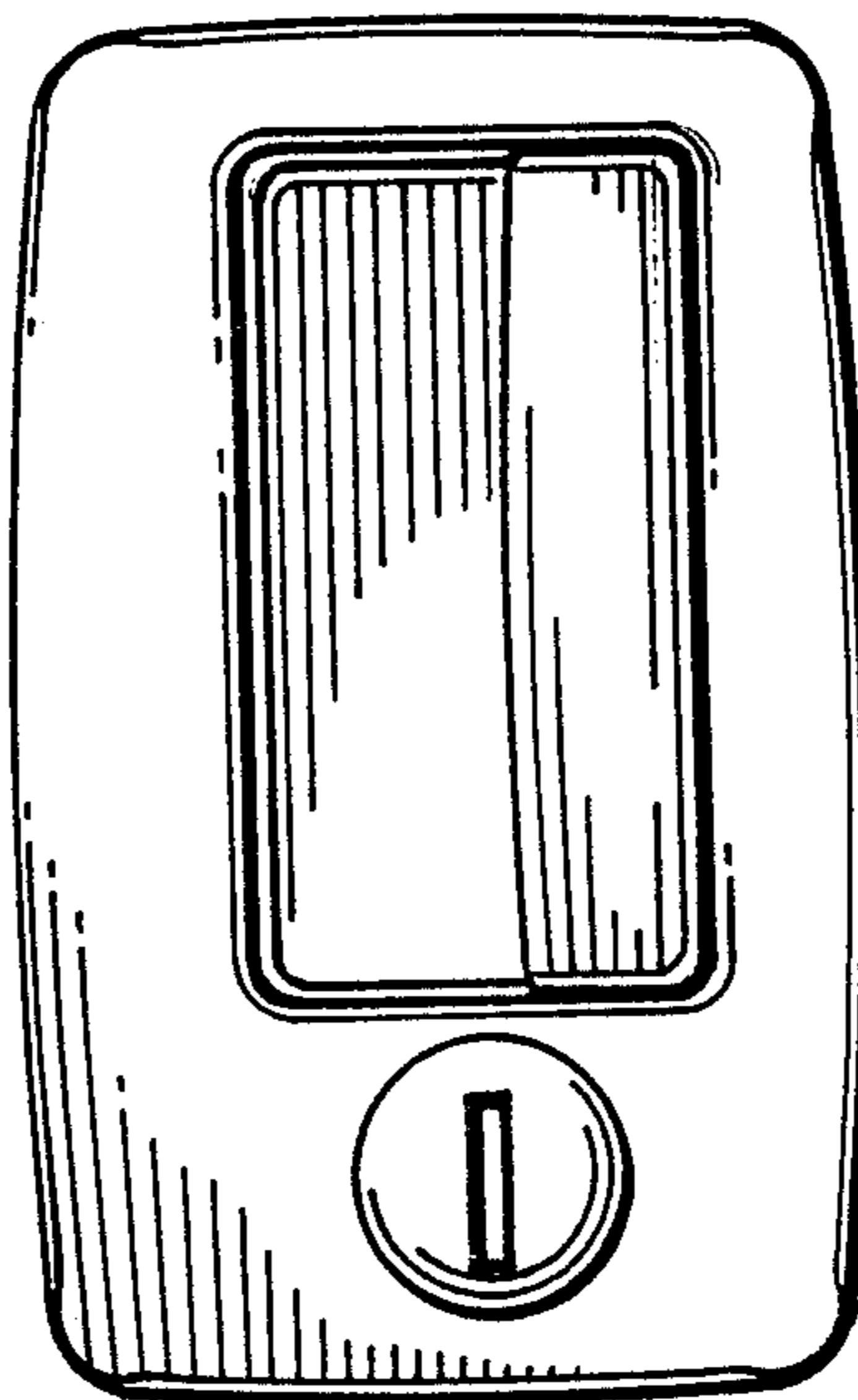

FIG. 28

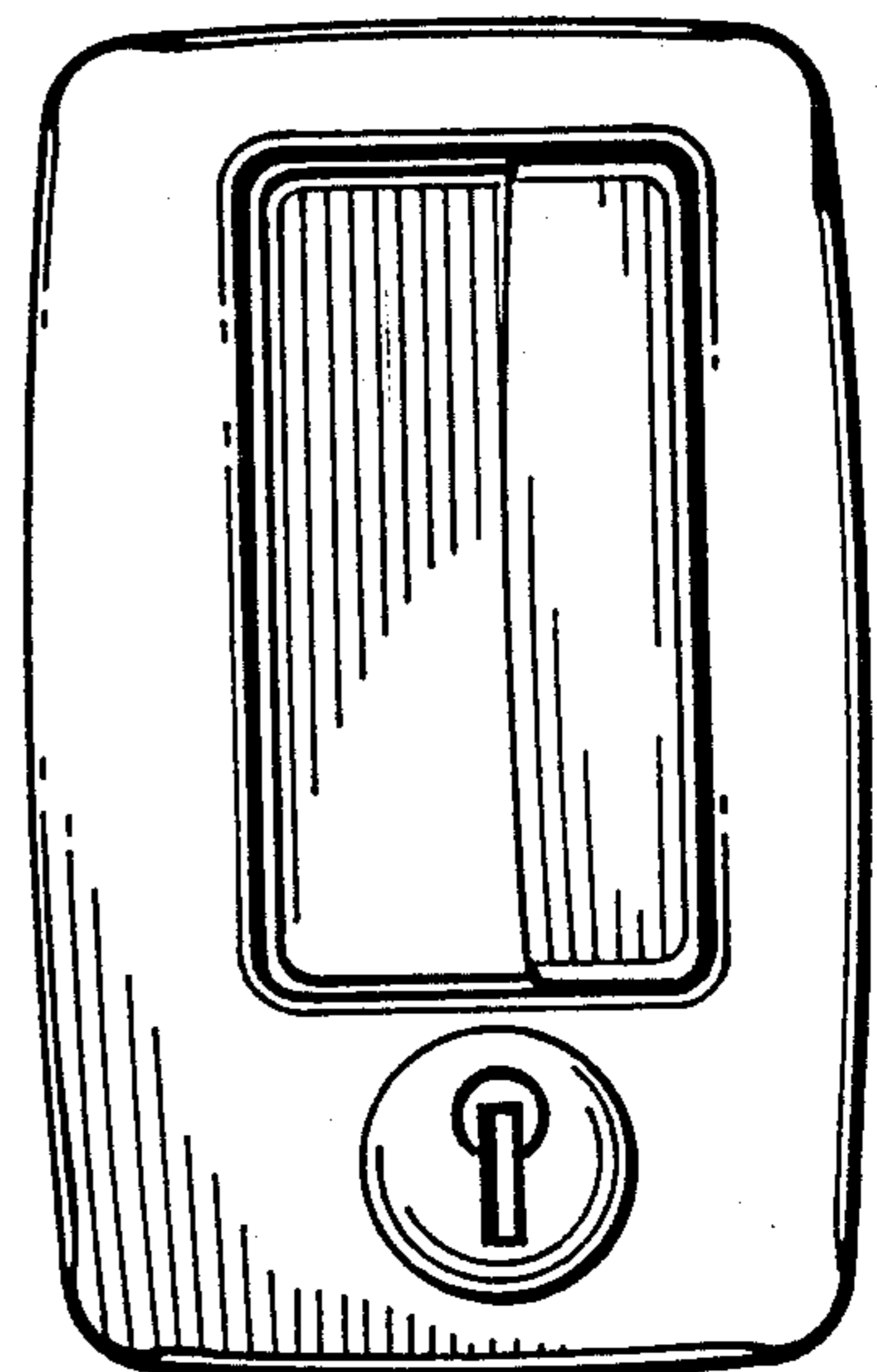

FIG. 29