

[54] TOTE BOX

[75] Inventor: Norman W. Pontbriand, Jr., Wallingford, Conn.

[73] Assignee: United Technologies Corporation, Hartford, Conn.

[**] Term: 14 Years

[21] Appl. No.: 65,192

[22] Filed: Jun. 22, 1987

[52] U.S. Cl. D34/43; D34/45

[58] Field of Search D34/40-46; D9/424, 425, 432, 433; 206/139, 203, 201, 499, 427, 510, 503, 513, 821; 220/1.5, 71-74, 83-84, DIG. 2, DIG. 12, DIG. 14, DIG. 15

[56] References Cited

U.S. PATENT DOCUMENTS

D. 198,236	5/1964	Schaefer	D34/44
D. 235,488	6/1975	Swalm	D34/44
D. 246,633	12/1977	Torokvei	D34/44
D. 255,094	5/1980	Wright	D34/45
D. 268,791	4/1983	Wood	D34/45 X
3,635,361	1/1972	Hayes	.	
3,756,396	9/1973	Kilroy	206/65
3,856,178	12/1974	Norgaard	220/23.83
3,878,980	4/1975	Crane	229/34 R
3,968,879	7/1976	Lucas, Sr. et al.	206/509
4,234,114	11/1980	Wood	206/510 X

4,247,004	1/1981	Bird	206/506
4,266,714	5/1981	Crane	229/34 HW
4,499,997	2/1985	Swingley, Jr.	206/509
4,655,360	4/1987	Juhanson	206/427 X
4,660,724	4/1987	Gaynes	206/509

FOREIGN PATENT DOCUMENTS

1239410	7/1960	France	.
1550780	of 1968	France	.
2428576	of 1980	France	.
674883	11/1964	Italy	.
892961	4/1962	United Kingdom	.
1202142	8/1970	United Kingdom	.

Primary Examiner—Bernard Ansher
Assistant Examiner—Prabhakar Deshmukh
Attorney, Agent, or Firm—William J. Sapone

[57] CLAIM

The ornamental design of a tote box, as shown and described.

DESCRIPTION

FIG. 1 is a front elevation of a tote box showing my new design;
FIG. 2 is a top plan view thereof;
FIG. 3 is a rear side elevation thereof;
FIG. 4 is a bottom plan view thereof;
FIG. 5 is a right side elevation thereof;
FIG. 6 is a left side elevation thereof; and
FIG. 7 is a sectional elevation taken along line 7—7 of FIG. 2.

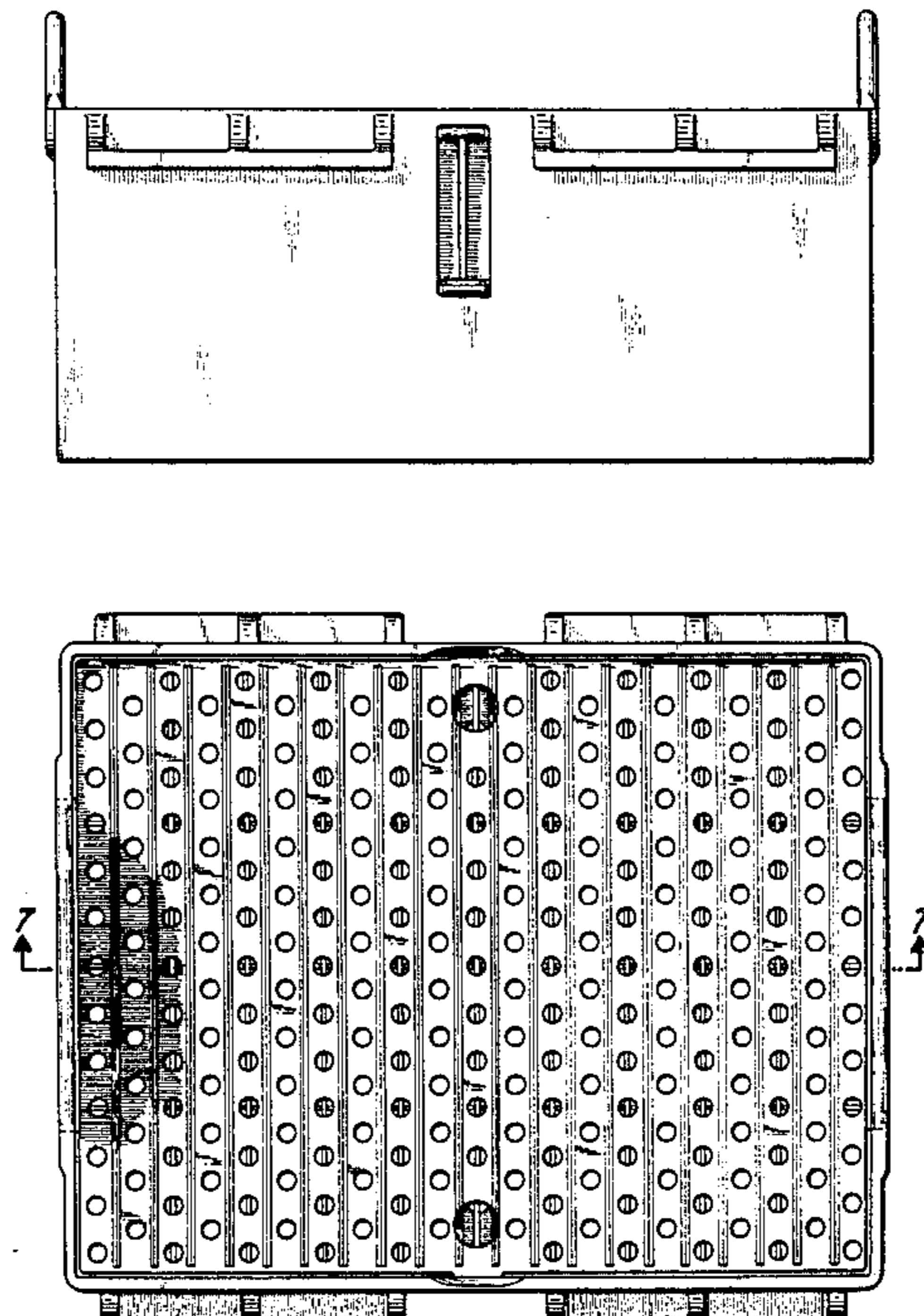

FIG. 1

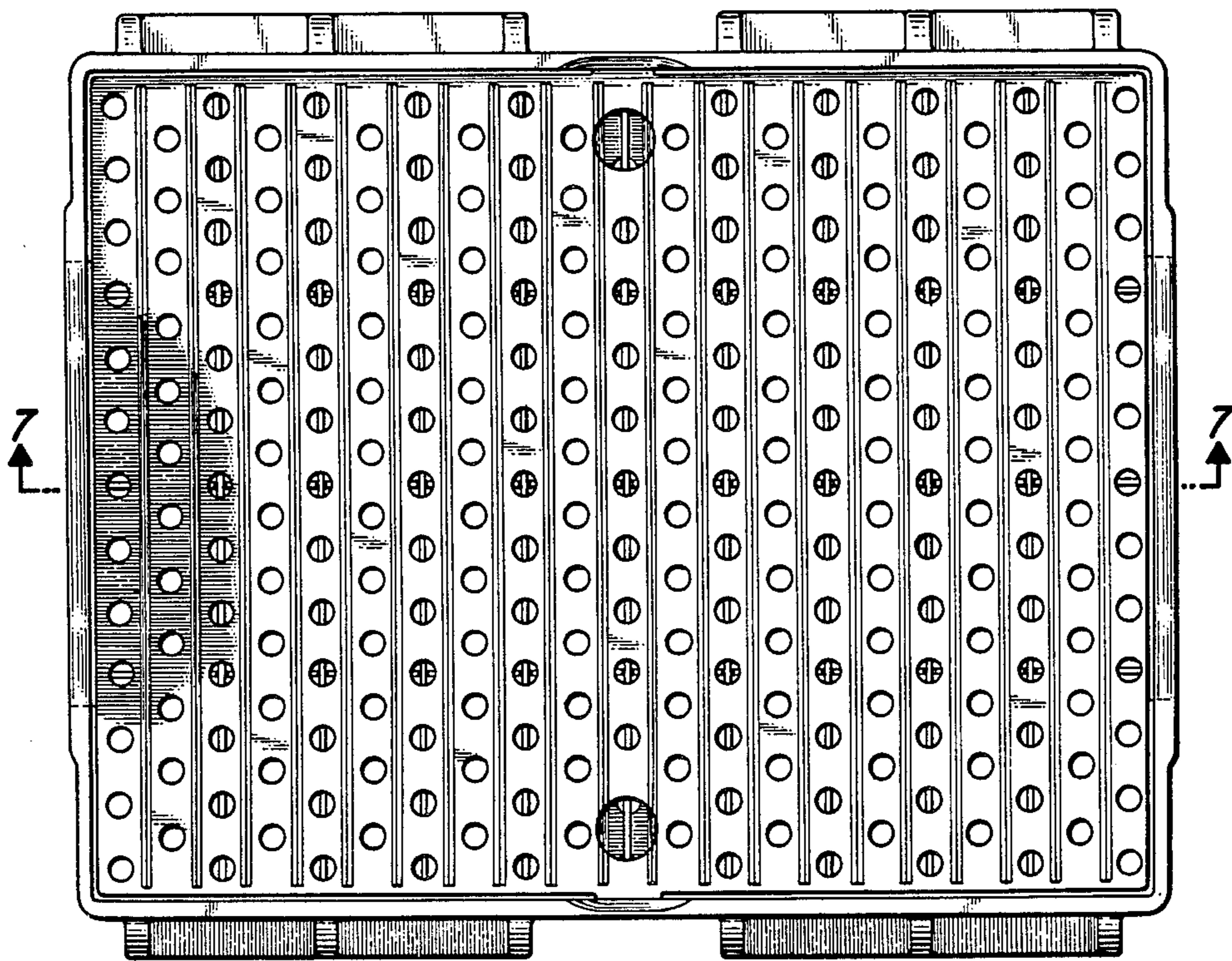
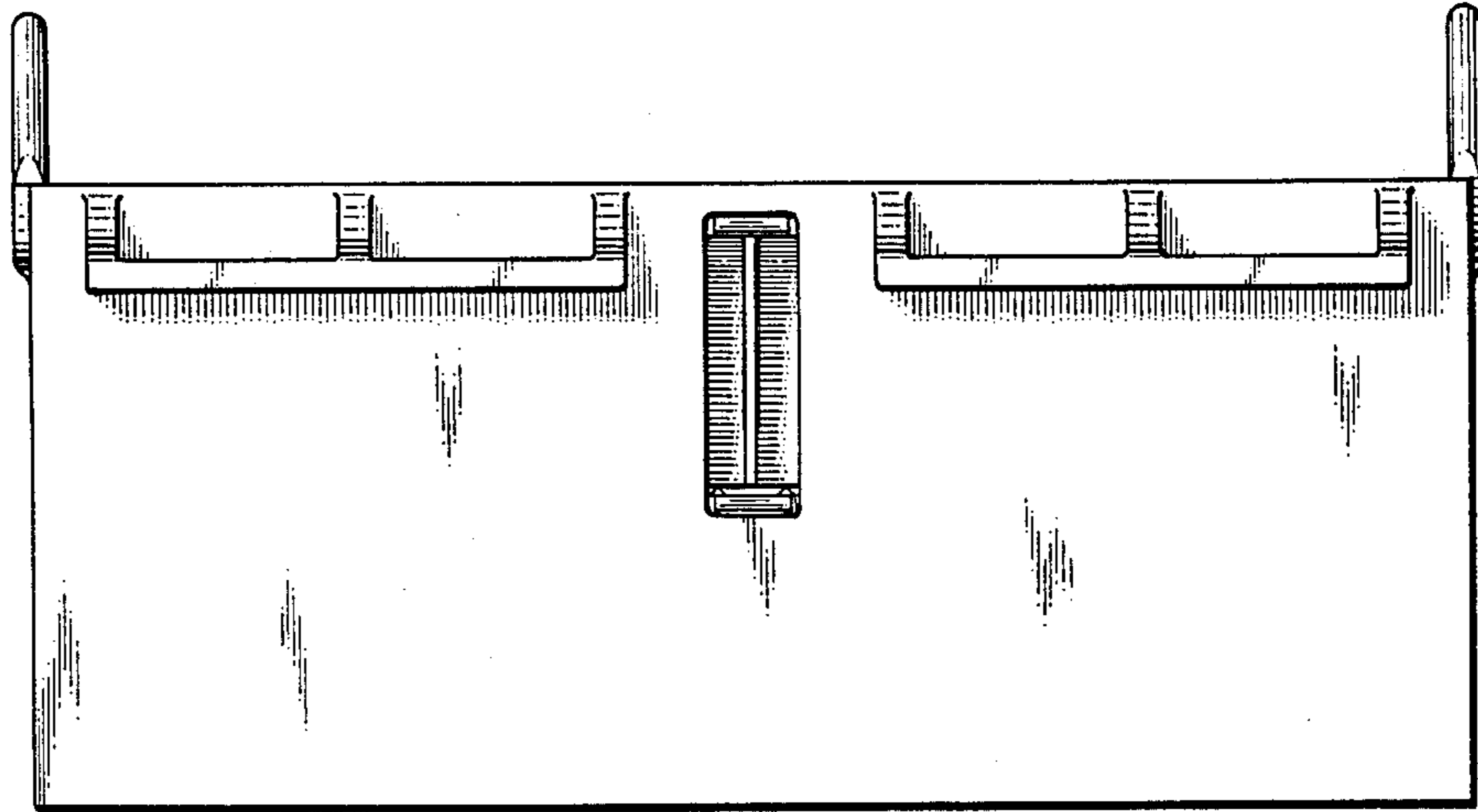

FIG. 2

FIG. 3

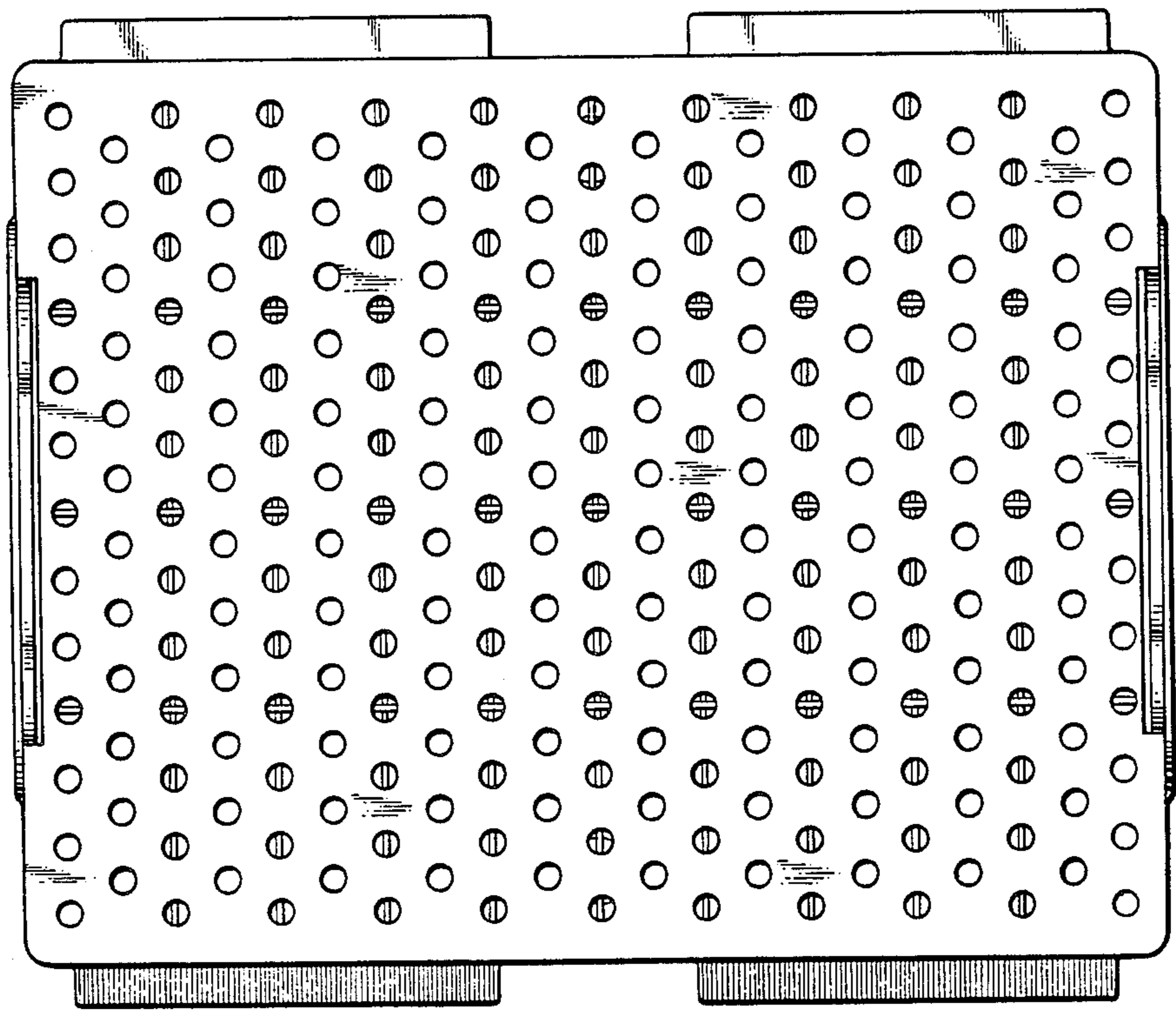
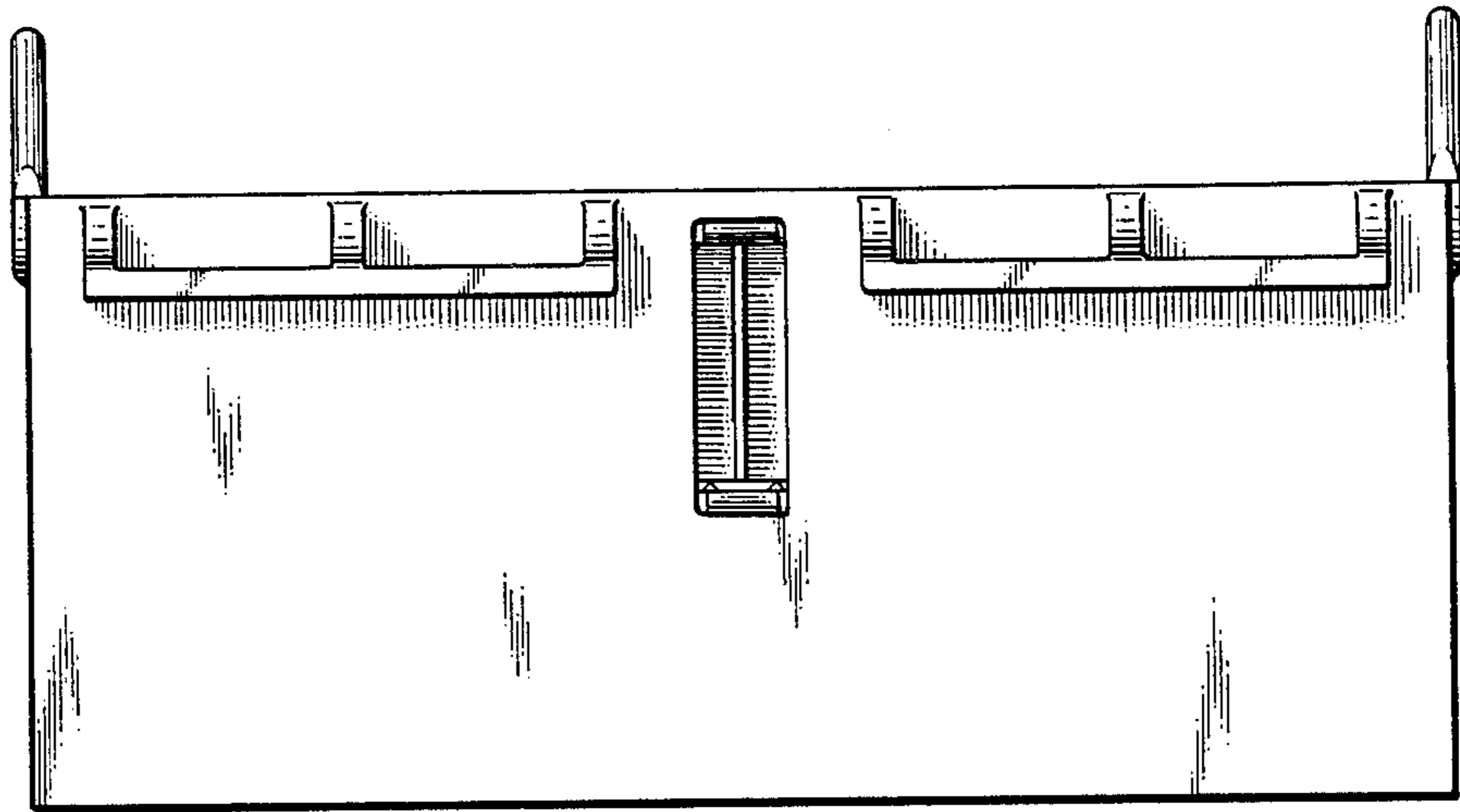

FIG. 4

FIG. 5

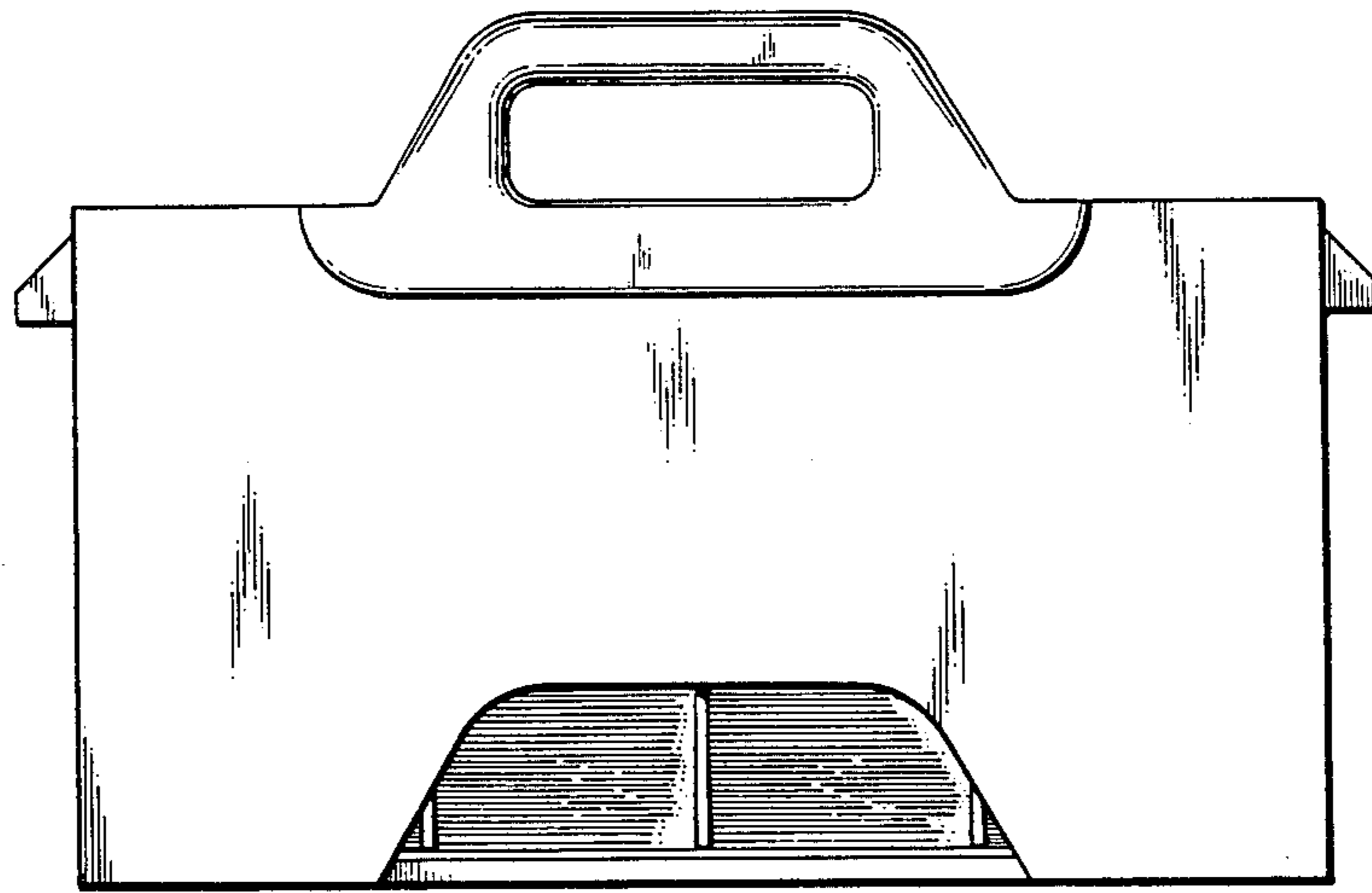
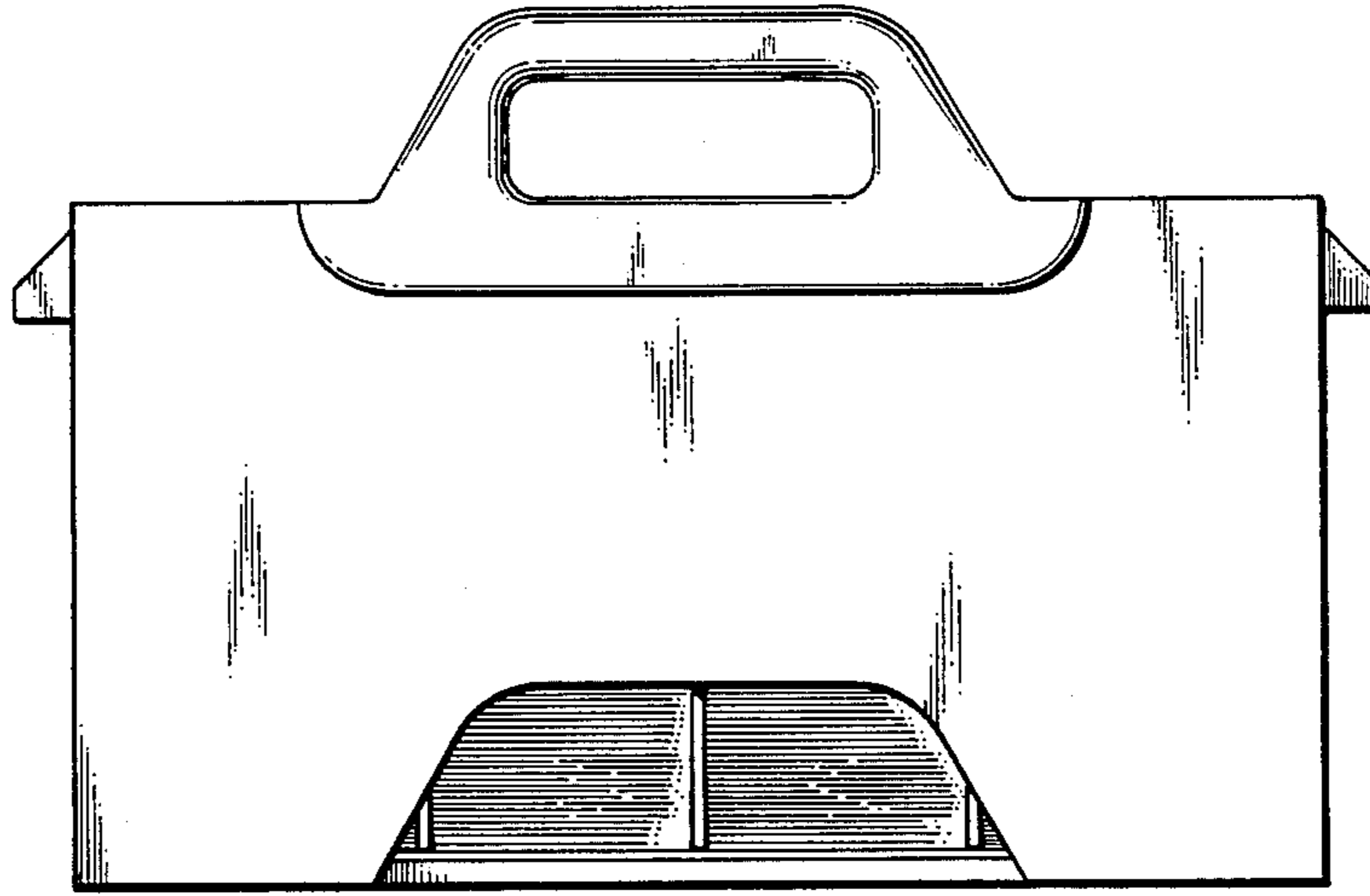

FIG. 6

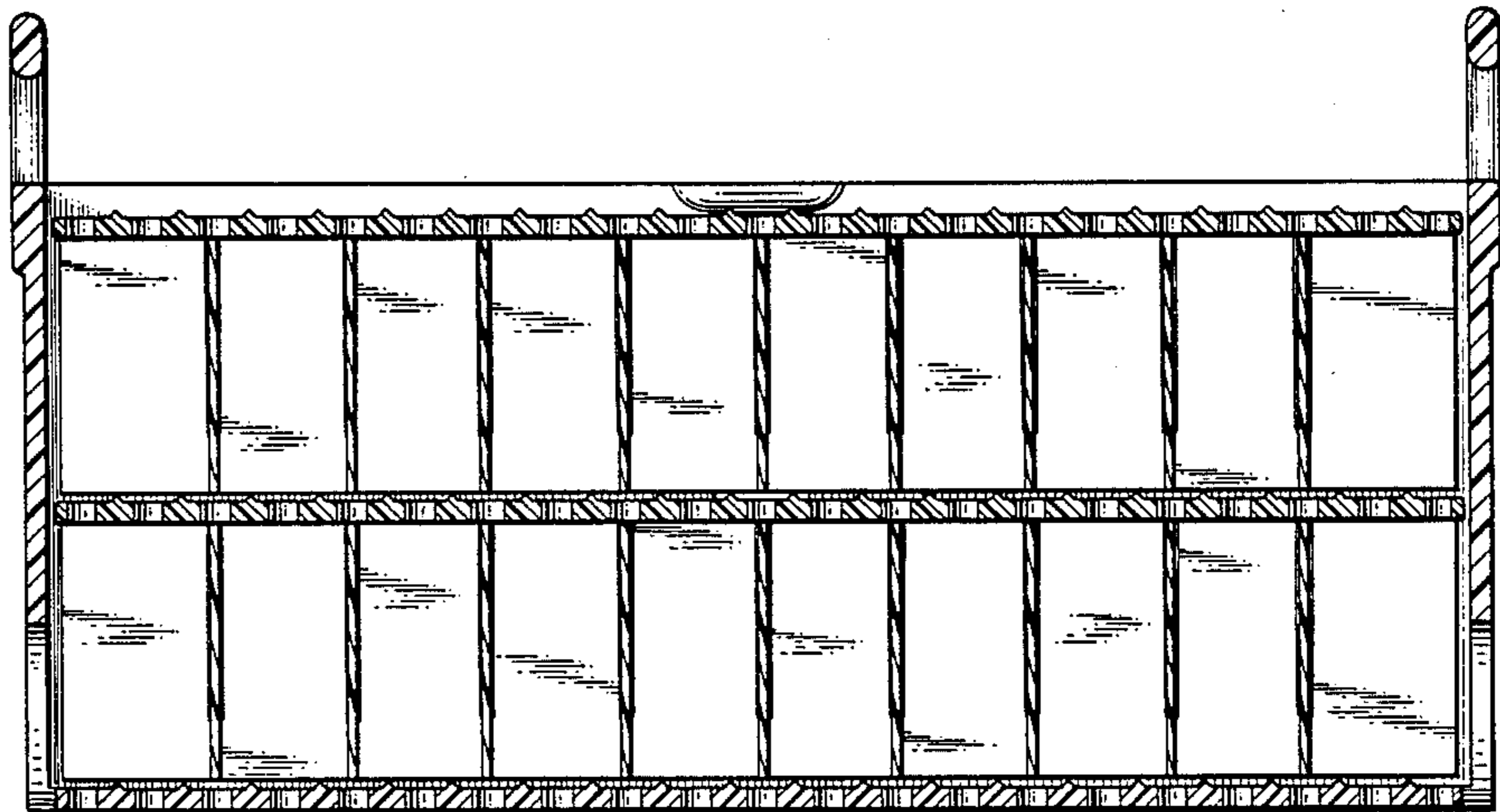

FIG. 7