

[54] EMERGENCY MEDICAL CRASH CART

[75] Inventor: Robert J. Welch, Dallas, Pa.

[73] Assignee: InterMetro Industries Corporation, Wilkes-Barre, Pa.

[\*\*] Term: 14 Years

[21] Appl. No.: 10,650

[22] Filed: Feb. 4, 1987

[52] U.S. Cl. .... D24/1.1

[58] Field of Search ..... D24/1.1; 312/209, 218, 312/216

[56] References Cited

U.S. PATENT DOCUMENTS

|            |        |                        |           |
|------------|--------|------------------------|-----------|
| D. 230,716 | 3/1974 | Ceranowicz et al. .... | D24/1.1 X |
| D. 263,995 | 4/1982 | Steele .....           | D24/1.1   |
| 3,428,383  | 2/1969 | Nobel .....            | 312/209   |
| 3,969,006  | 7/1976 | Brown .....            | 312/209 X |
| 4,583,795  | 4/1986 | Brown et al. ....      | 312/209   |
| 4,652,062  | 3/1987 | Greenwood .....        | 312/209   |

Primary Examiner—Wallace R. Burke.  
Assistant Examiner—Stella M. Reid  
Attorney, Agent, or Firm—Fitzpatrick, Cella, Harper & Scinto

[57] CLAIM

The ornamental design for an emergency medical crash cart, as shown and described.

DESCRIPTION

FIG. 1 is a front, right perspective view of an emergency medical crash cart showing my new design, with the handle in upright position;  
FIG. 2 is a right side elevational view thereof;  
FIG. 3 is a left side elevational view thereof;  
FIG. 4 is a rear elevational view thereof;  
FIG. 5 is a front elevational view thereof;  
FIG. 6 is a top plan view thereof;  
FIG. 7 is a bottom plan view thereof; and  
FIG. 8 is a rear, left perspective view thereof, with the handle in collapsed position.

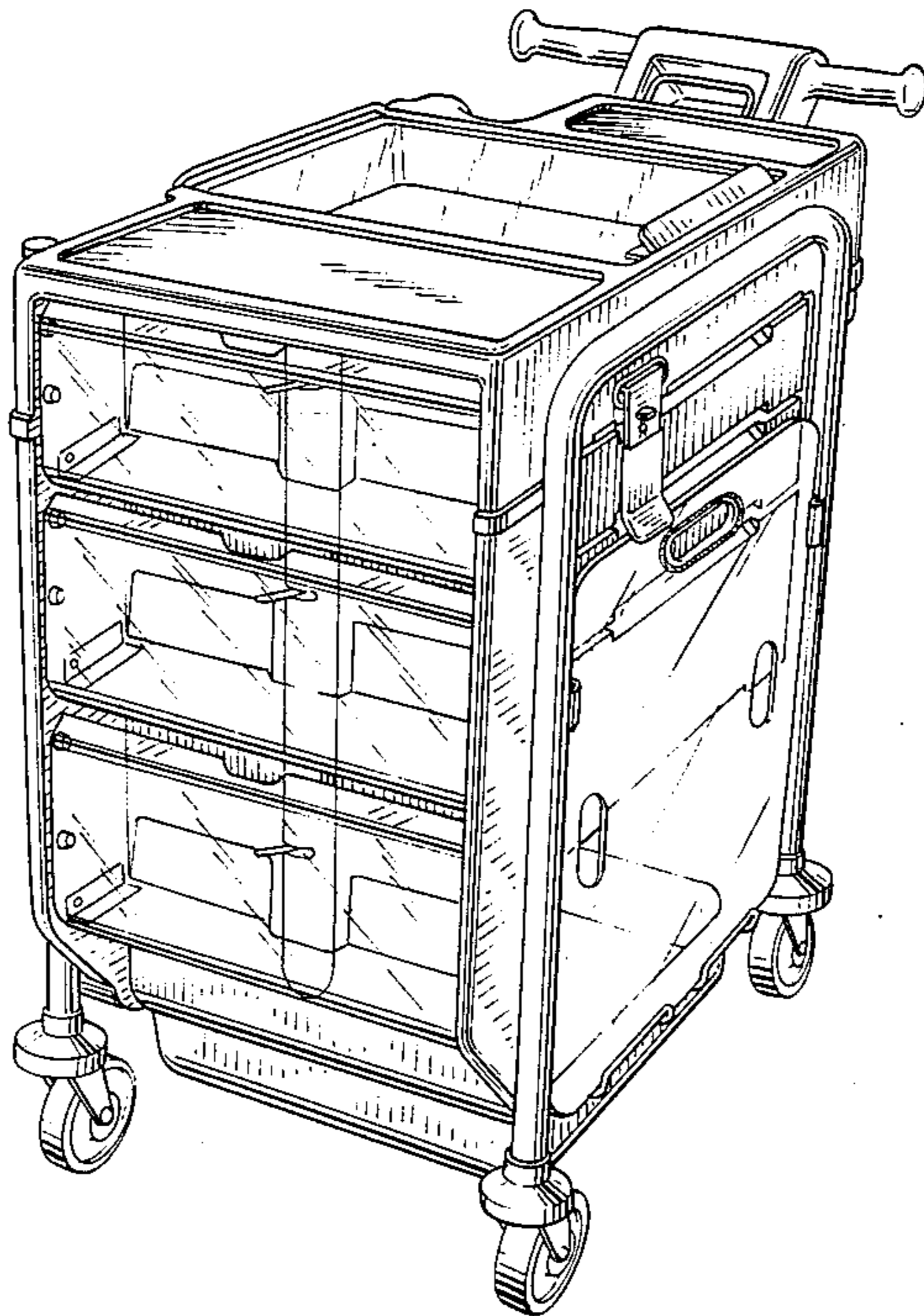

FIG. 1

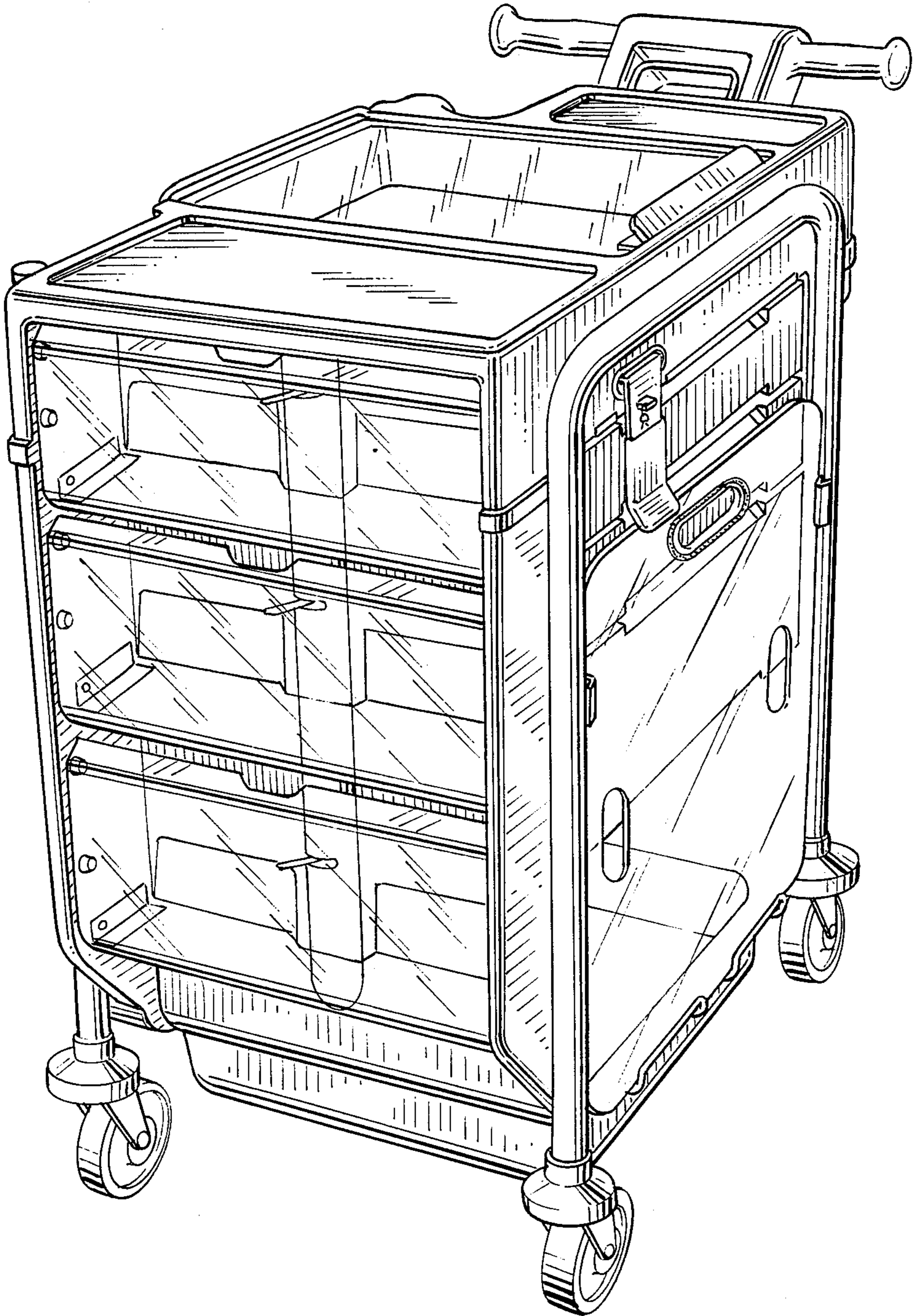

FIG. 2

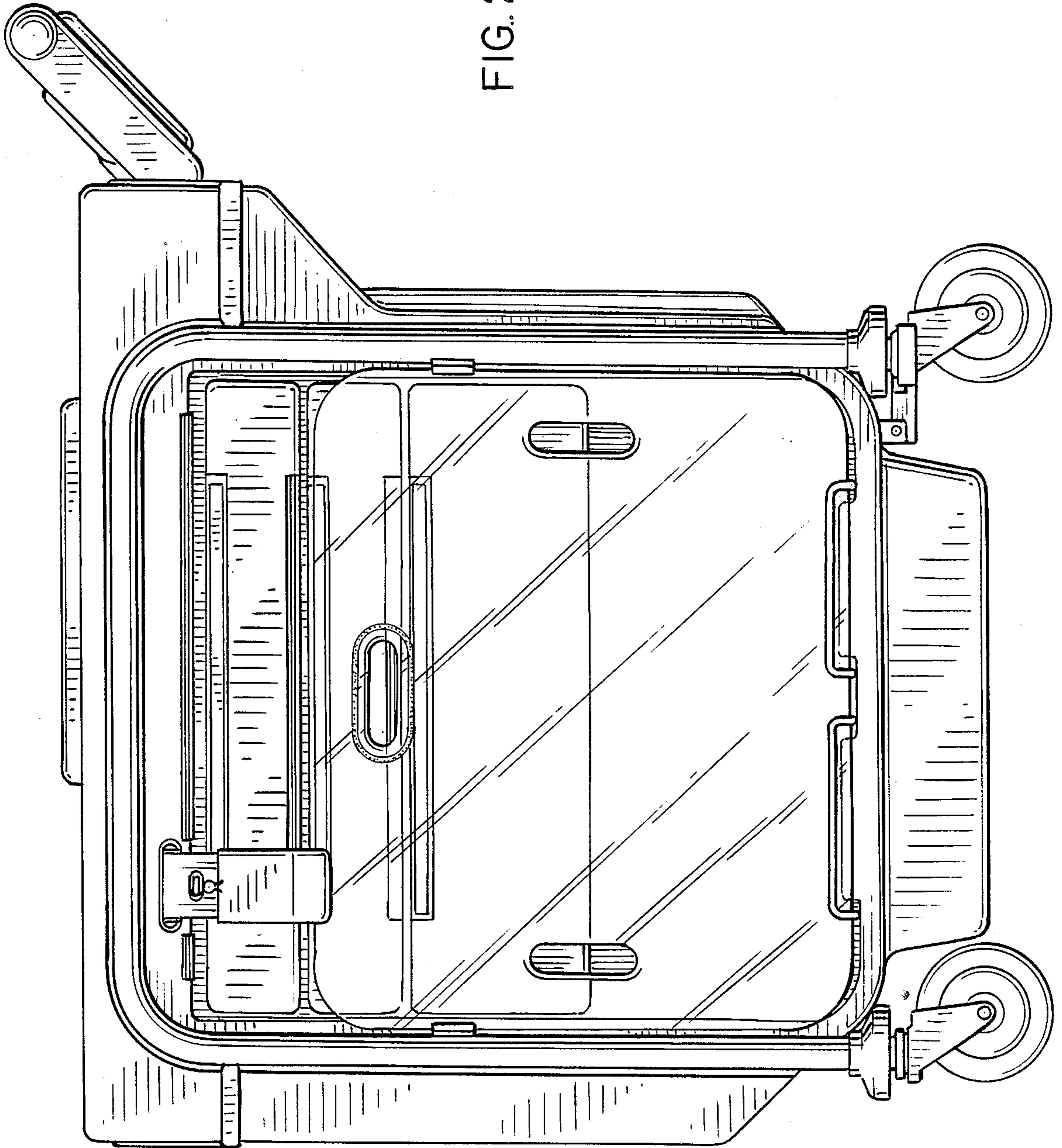

FIG. 3

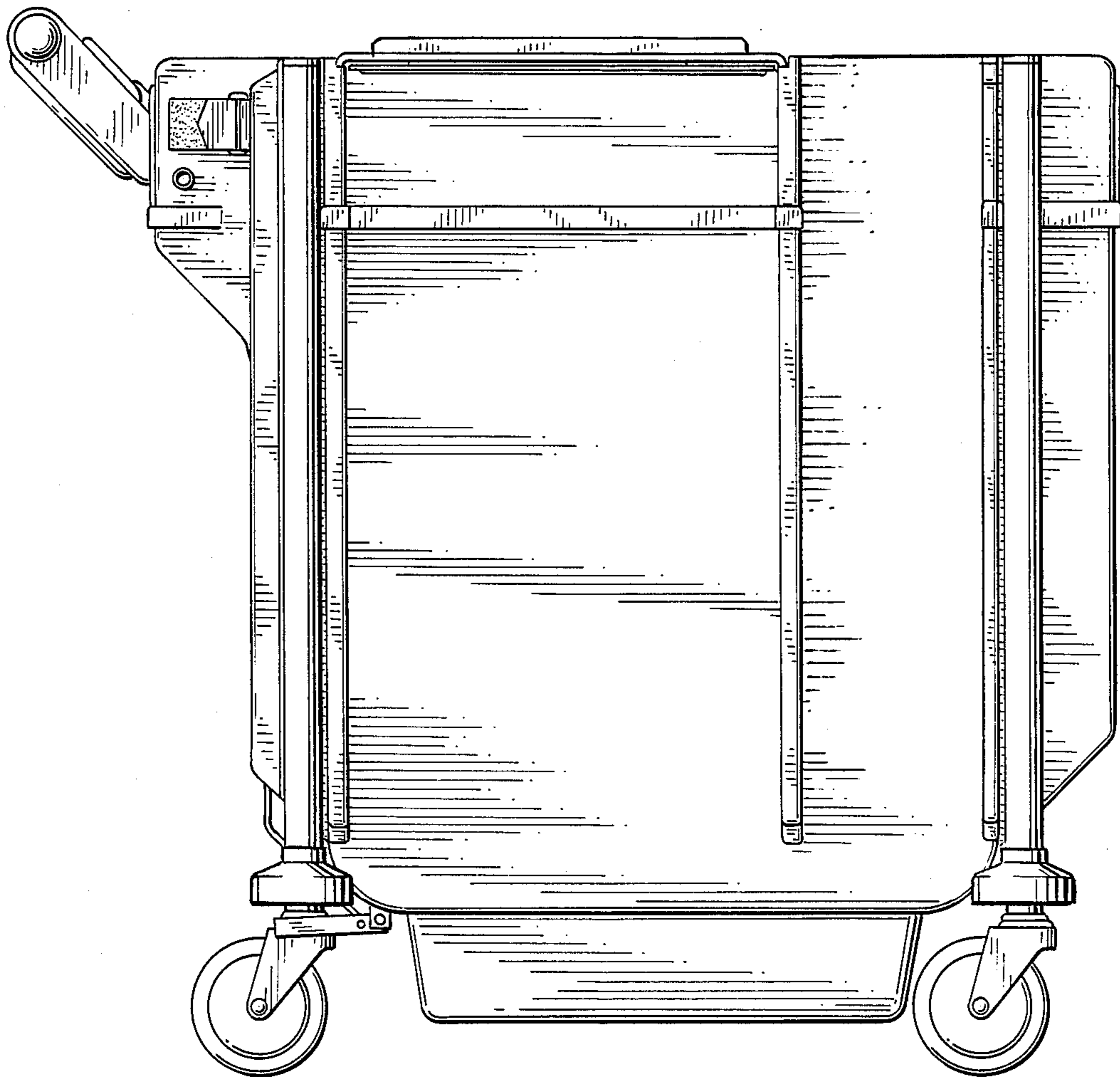

FIG. 5

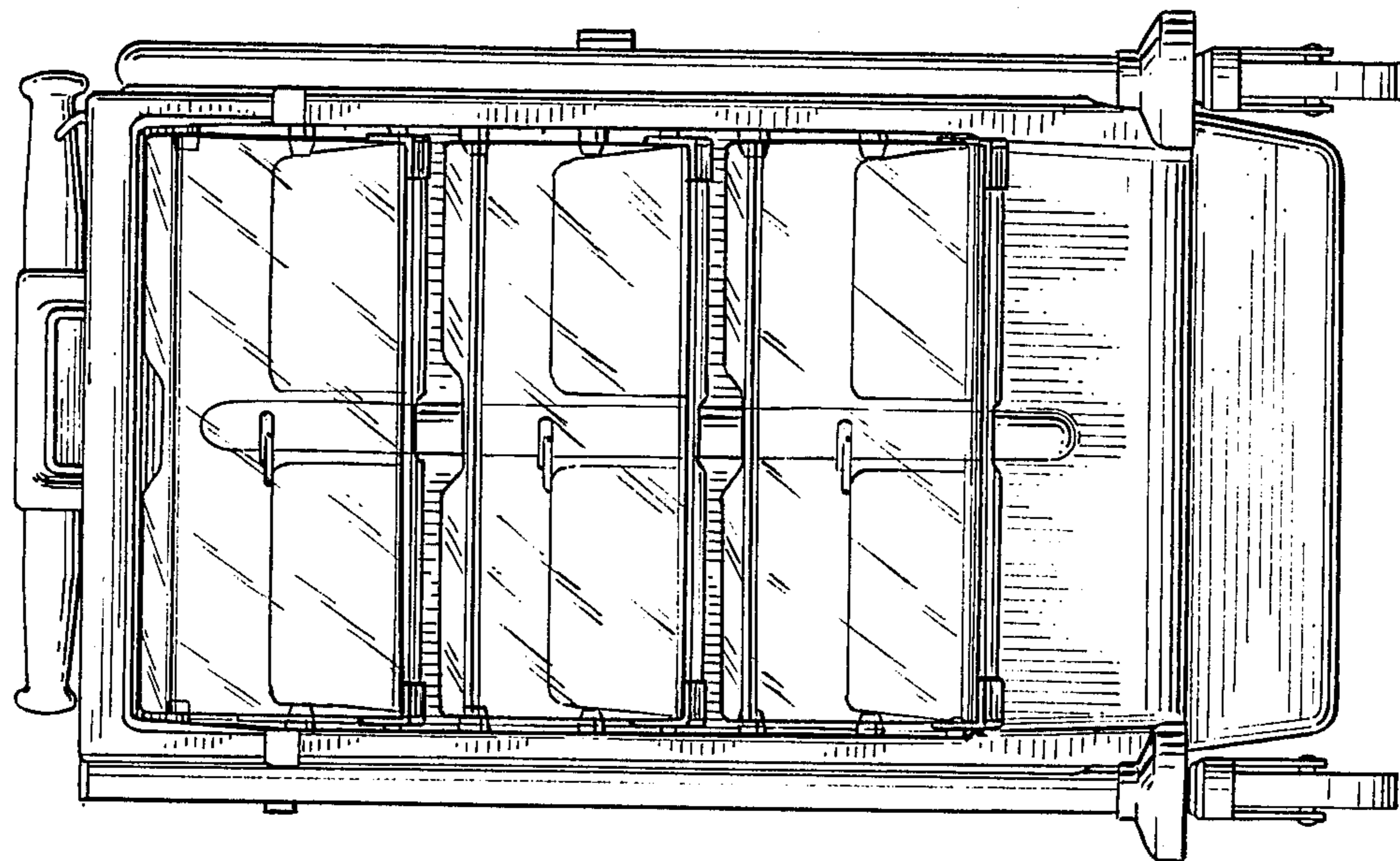

FIG. 4

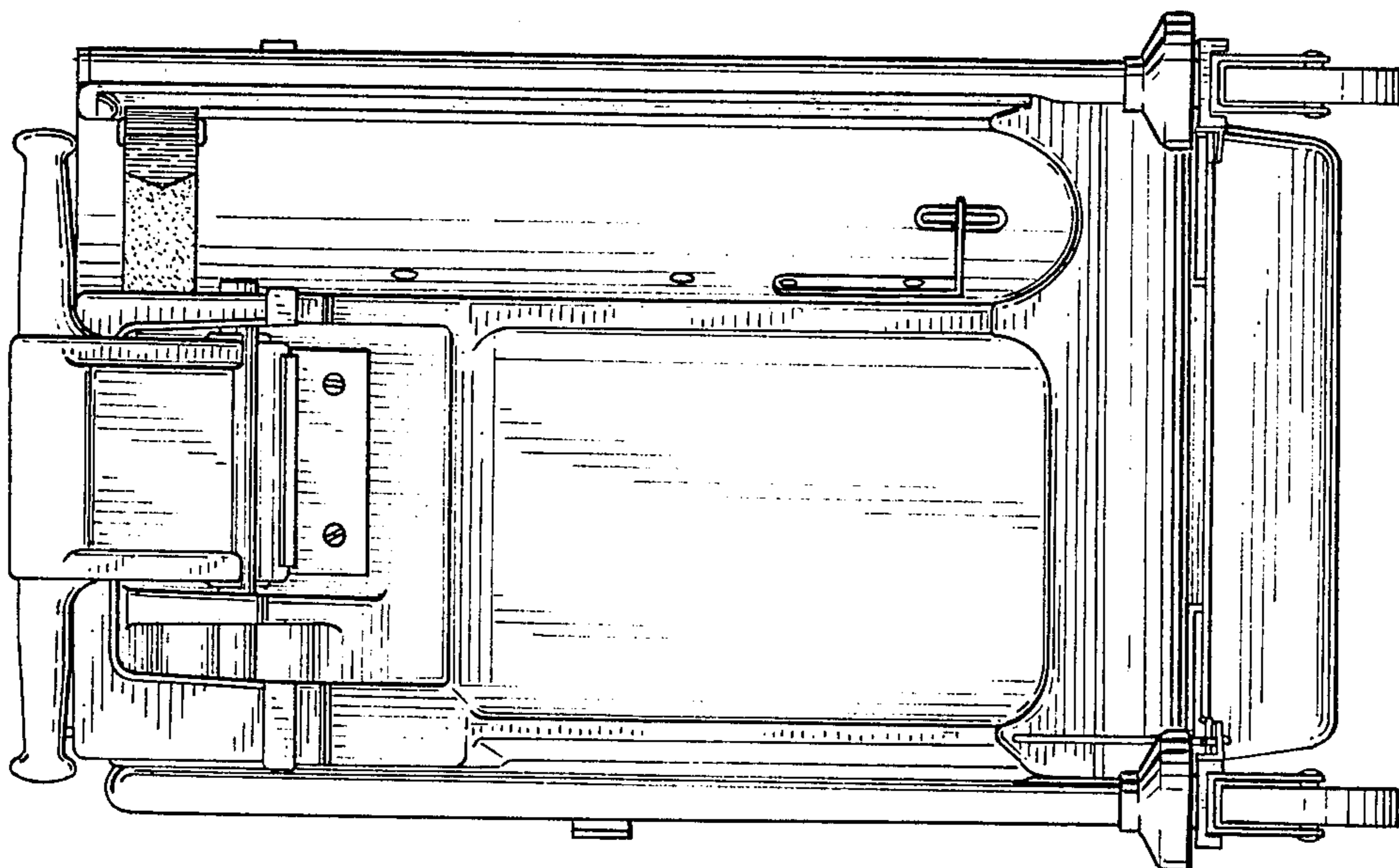

FIG. 8

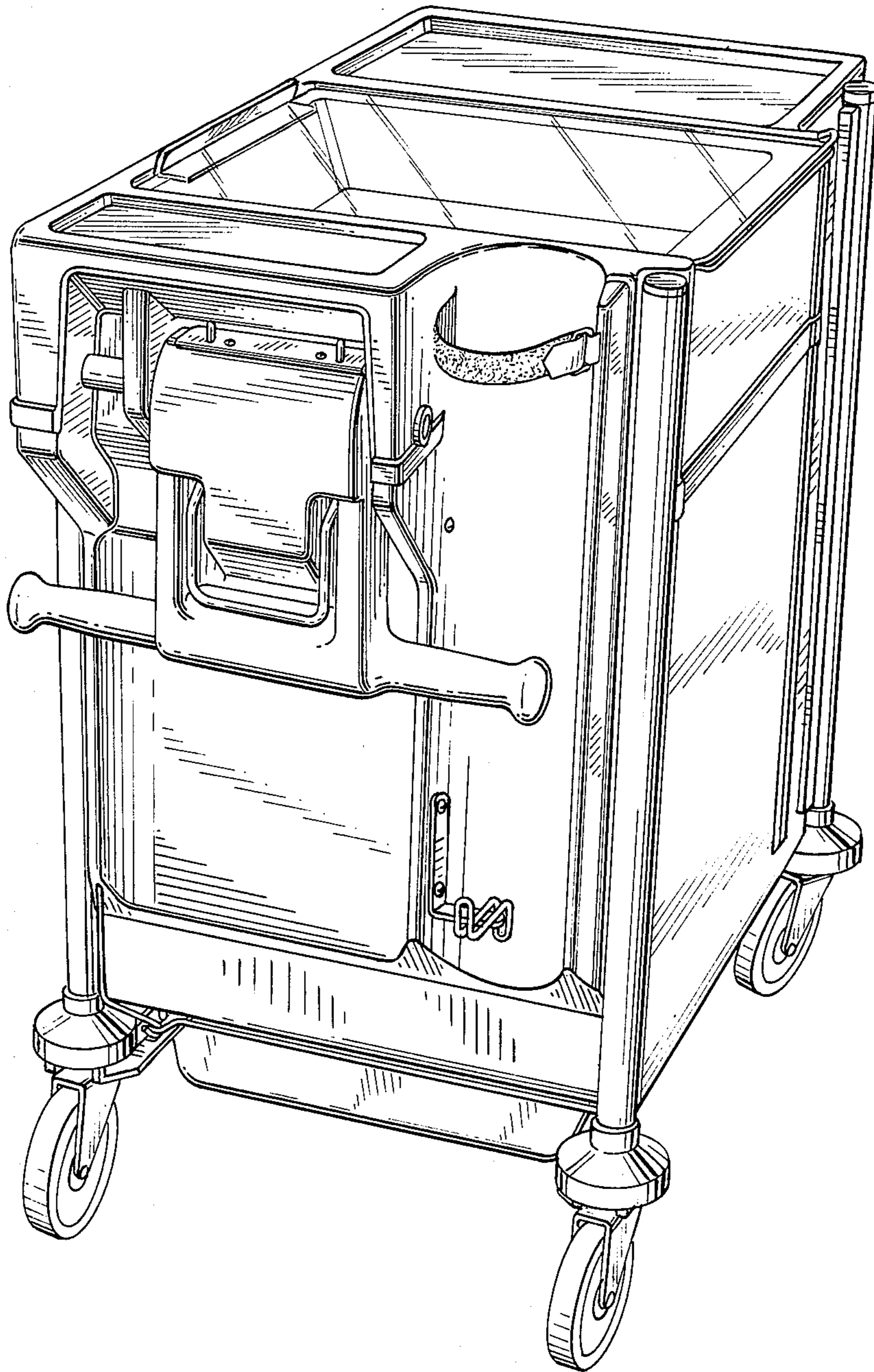

FIG. 6

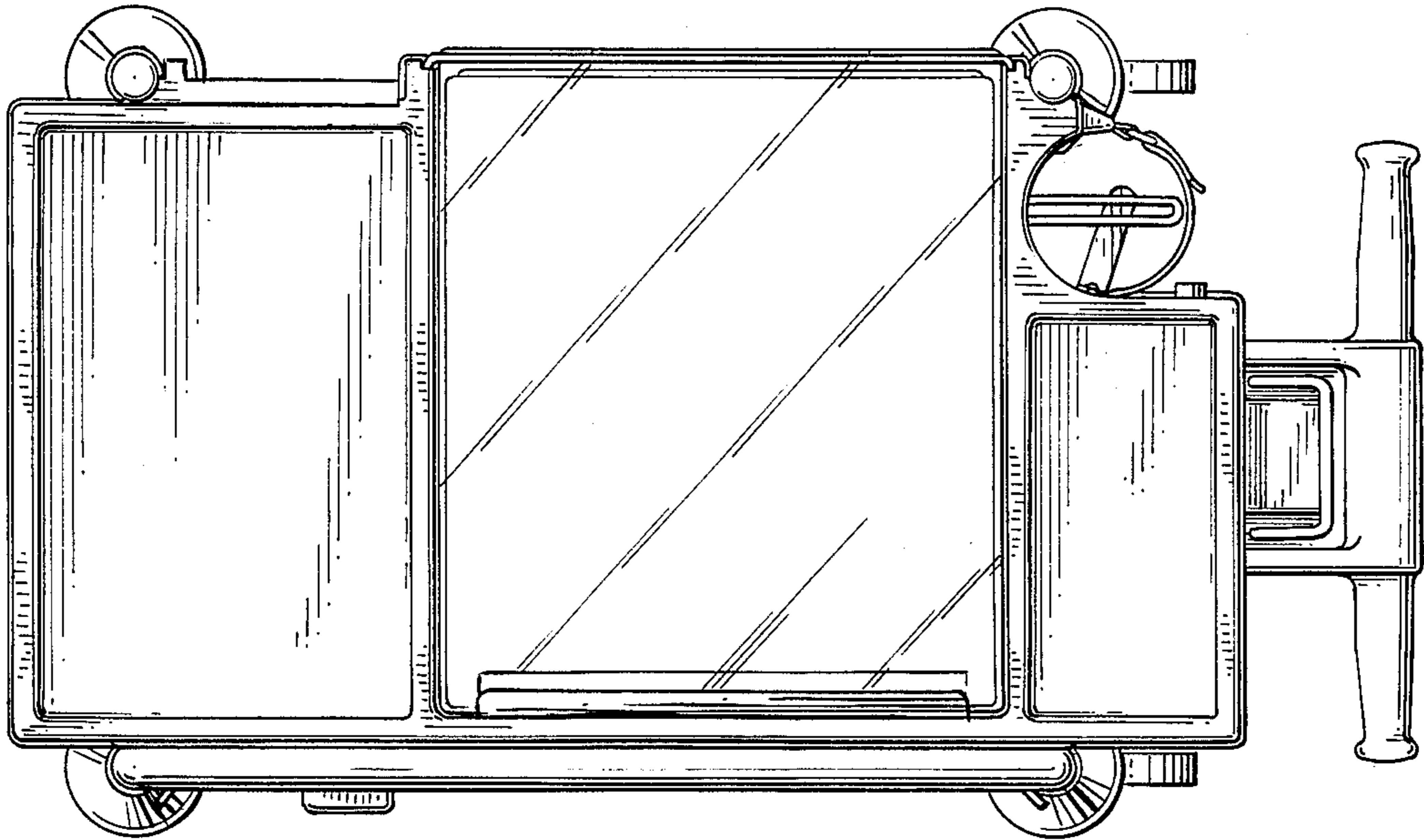
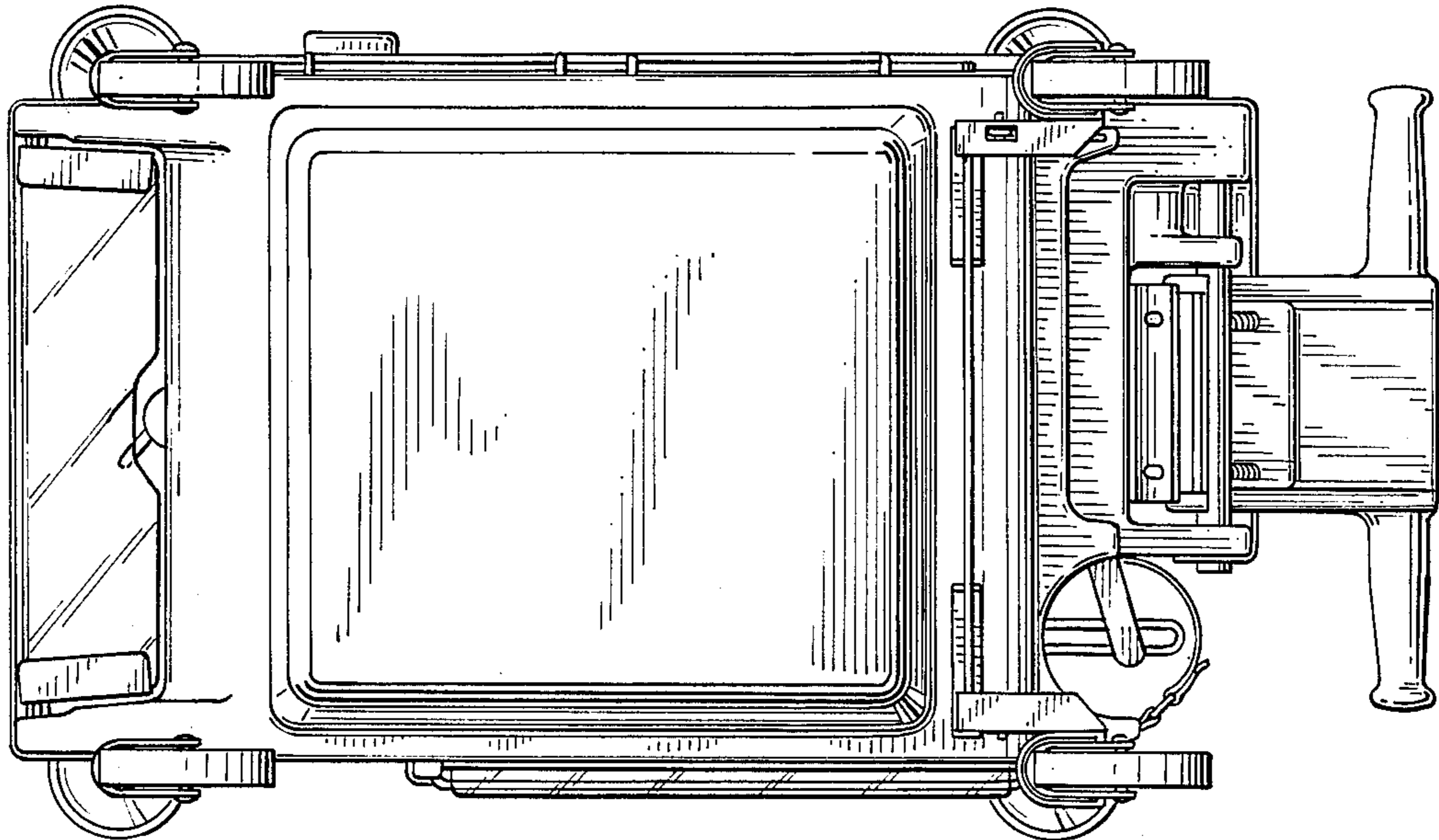

FIG. 7



UNITED STATES PATENT AND TRADEMARK OFFICE  
CERTIFICATE OF CORRECTION

PATENT NO. : Des. 304,075  
DATED : October 17, 1989  
INVENTOR(S) : ROBERT J. WELCH

It is certified that error appears in the above-identified patent and that said Letters Patent is hereby corrected as shown below:

ON THE TITLE PAGE, AT [56] REFERENCES CITED

After "4,652,062 3/1987 Greenwood ... 312/209"  
insert

--Foreign Patent Documents

1,144,064 2/1963 West Germany

Other Documents

Emergency Trolley EMT 300/2, S&W Teknik, A/S,

Denmark Mehrzwechwagen, Germany, pp. 14,18,31--.

Signed and Sealed this  
Twenty-eighth Day of May, 1991

*Attest:*

HARRY E. MANBECK, JR.

*Attesting Officer*

*Commissioner of Patents and Trademarks*