

[54] **PRINTER FOR CASH REGISTER**

[75] Inventor: **Maki Tomoike, Osaka, Japan**

[73] Assignee: **Sharp Kabushiki Kaisha, Osaka, Japan**

[\*\*] Term: **14 Years**

[21] Appl. No.: **922,109**

[22] Filed: **Oct. 20, 1986**

[30] **Foreign Application Priority Data**

Apr. 22, 1986 [JP] Japan ..... 61-15404

[52] U.S. Cl. .... **D18/13**

[58] Field of Search ..... D14/100, 107, 111;  
D18/3, 4, 11, 12, 13, 14, 99; 235/3, 379, 380;  
364/401, 405, 406, 407

[56] **References Cited**

**U.S. PATENT DOCUMENTS**

D. 215,676 10/1969 Majesty ..... D14/111

D. 224,666 8/1972 Schmeek et al. .... D18/13

D. 236,489 8/1975 Pycha et al. .... D14/107  
D. 253,820 1/1980 Coppola et al. .... D14/100  
D. 264,600 5/1982 Yamasaki et al. .... D18/4  
D. 286,152 10/1986 Norton et al. .... D14/107  
D. 294,357 2/1988 Klein et al. .... D18/13 X  
D. 294,367 2/1988 Nishibori et al. .... D18/4  
4,720,785 1/1988 Shapiro ..... 235/378 X

*Primary Examiner*—James R. Largen  
*Attorney, Agent, or Firm*—Flehr, Hohbach, Test,  
Albritton & Herbert

[57] **CLAIM**

The ornamental design for a printer for cash register, as shown and described.

**DESCRIPTION**

FIG. 1 is a front elevational view of the printer for cash register showing my new design;  
FIG. 2 is a top plan view thereof;  
FIG. 3 is a rear elevational view thereof;  
FIG. 4 is a bottom plan view thereof;  
FIG. 5 is a right side elevational view thereof; and  
FIG. 6 is a left side elevational view thereof.

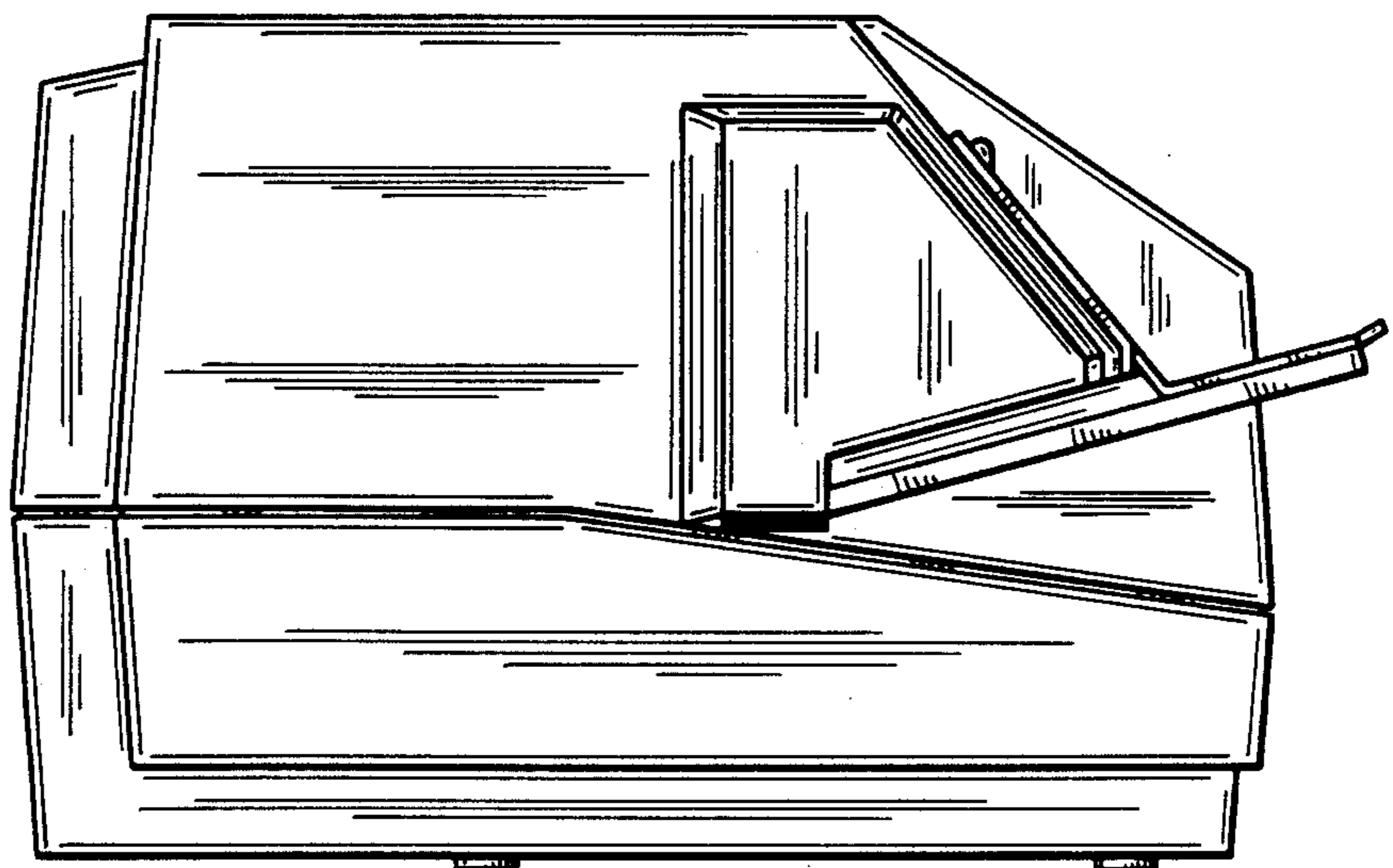
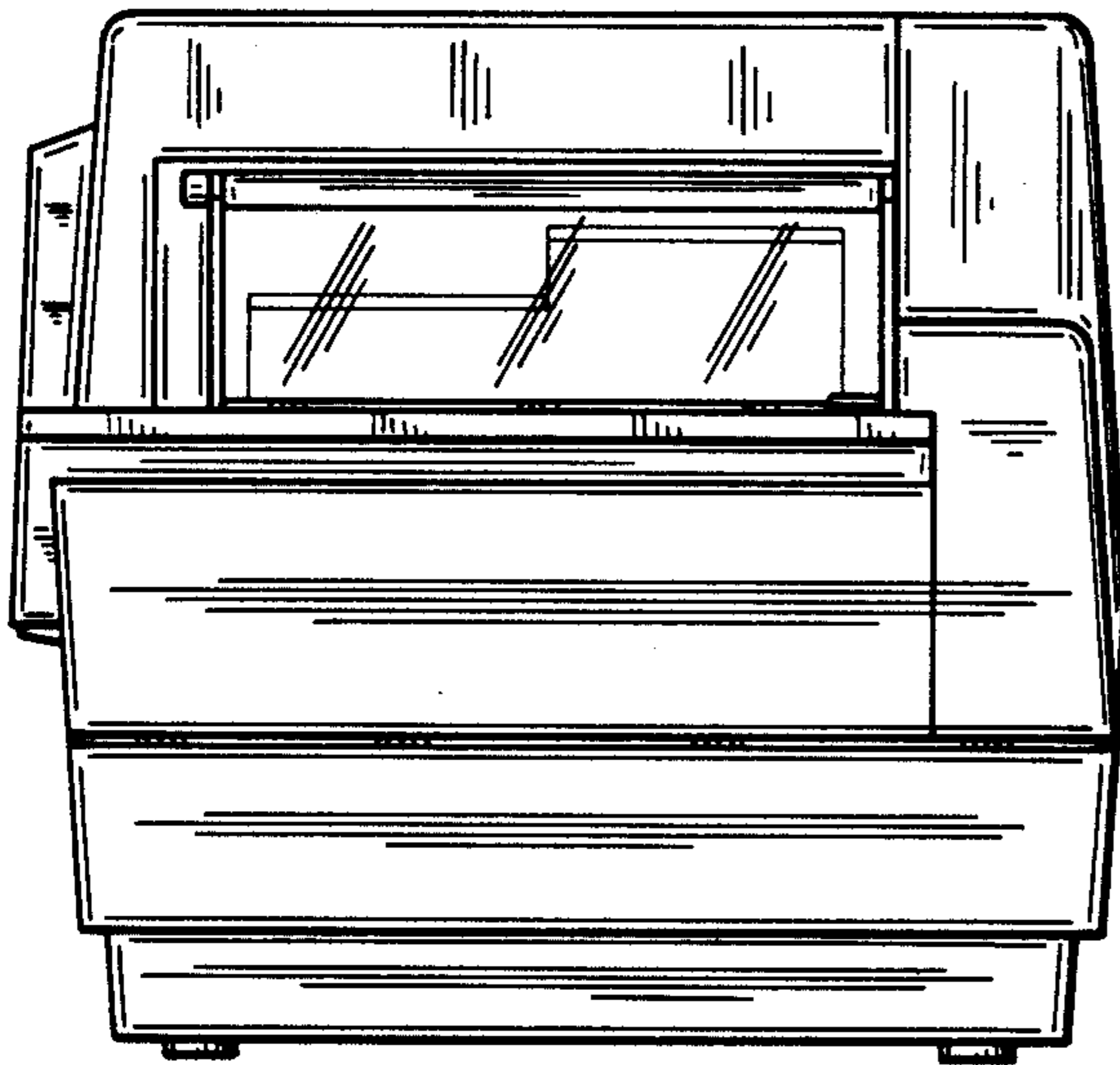

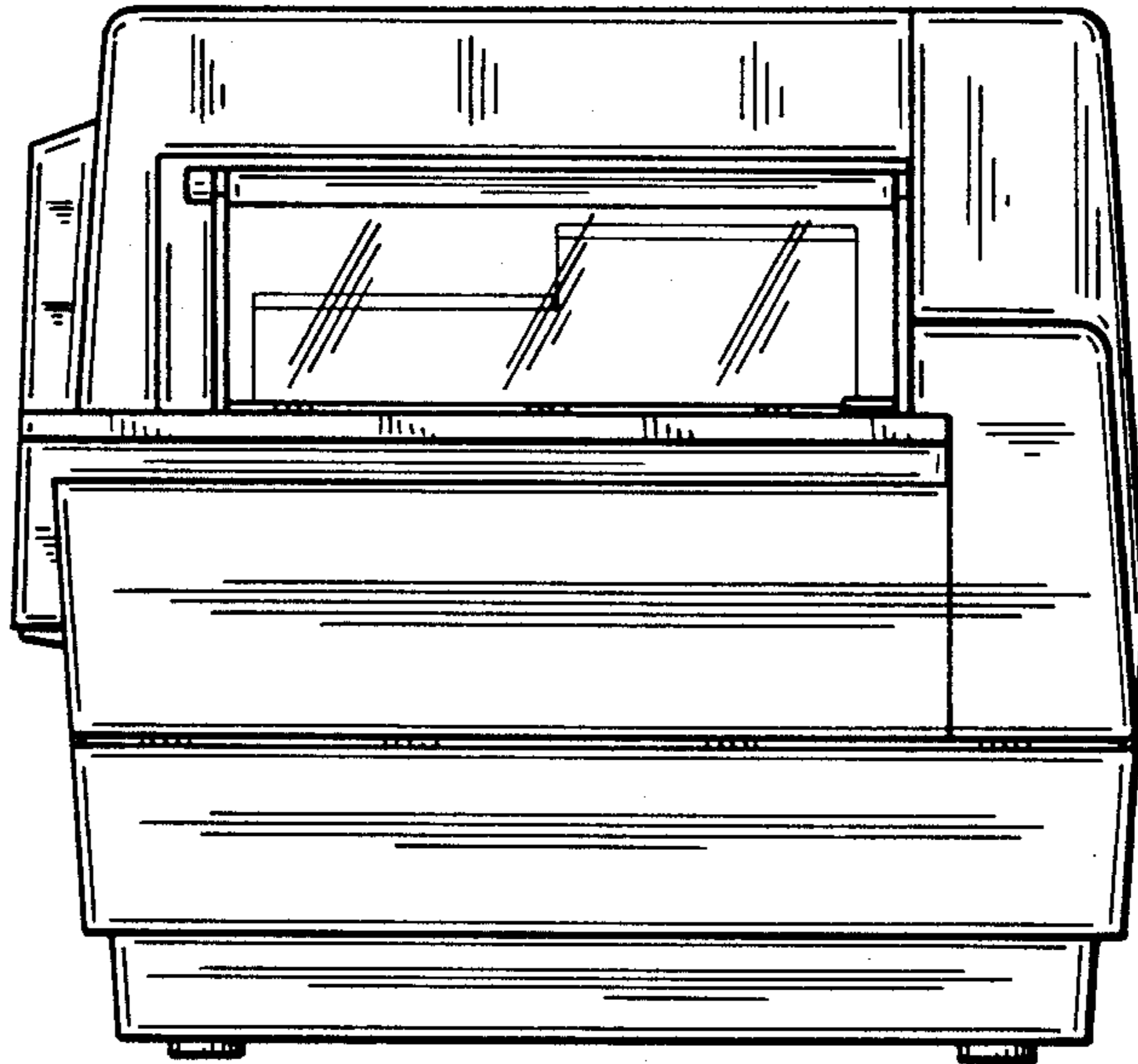

*FIG\_1*

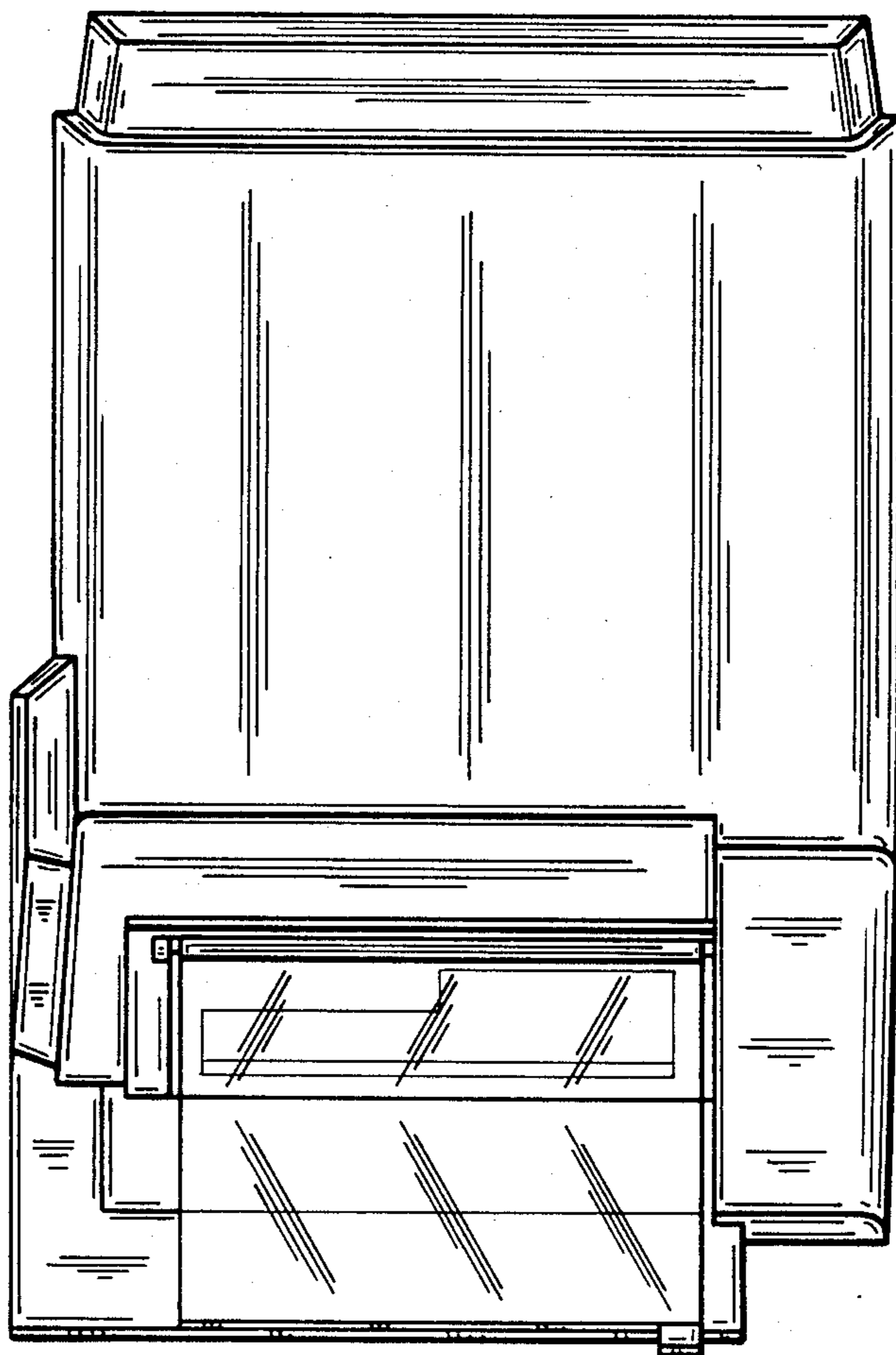

*FIG\_2*

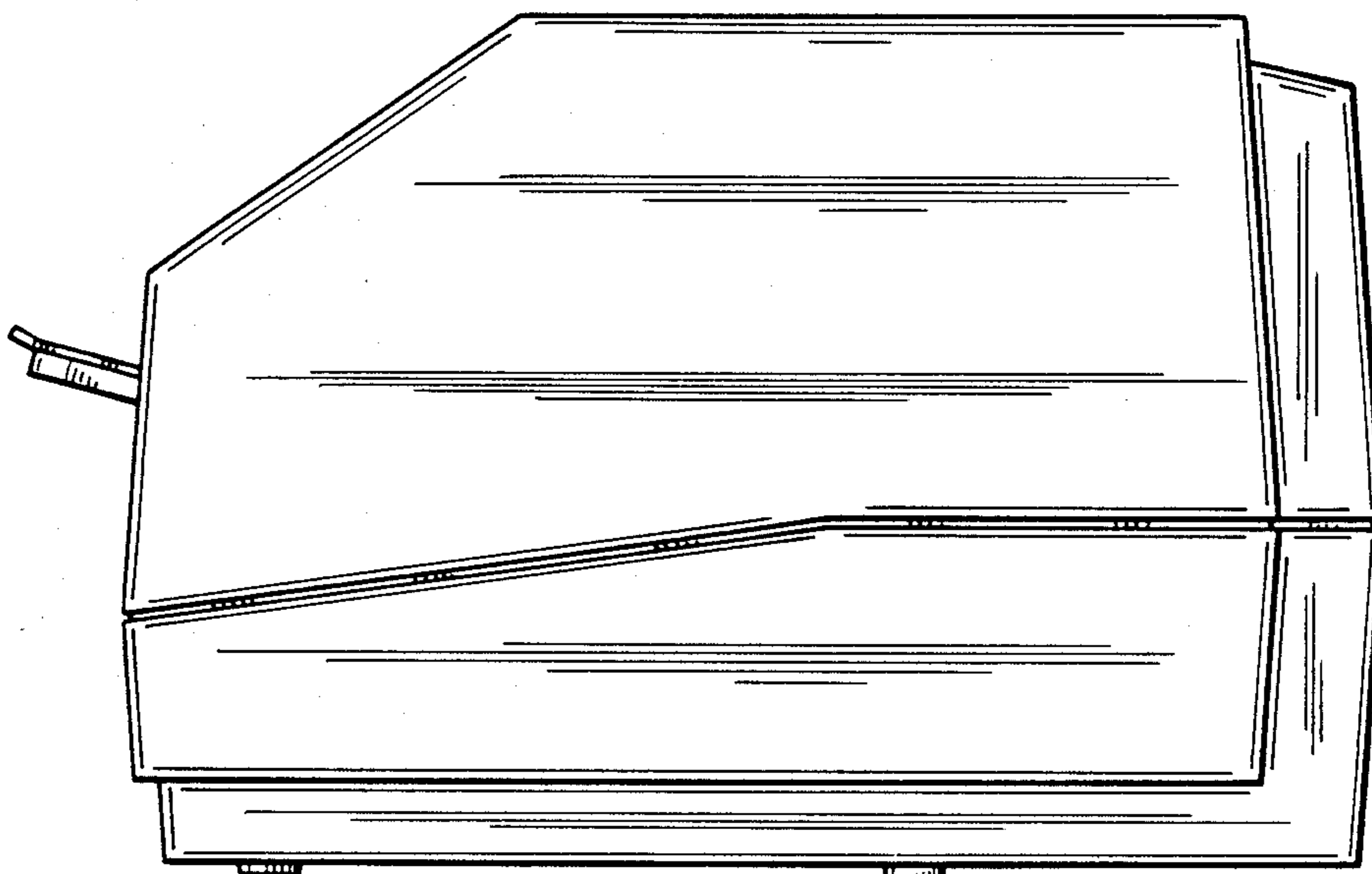

FIG\_5

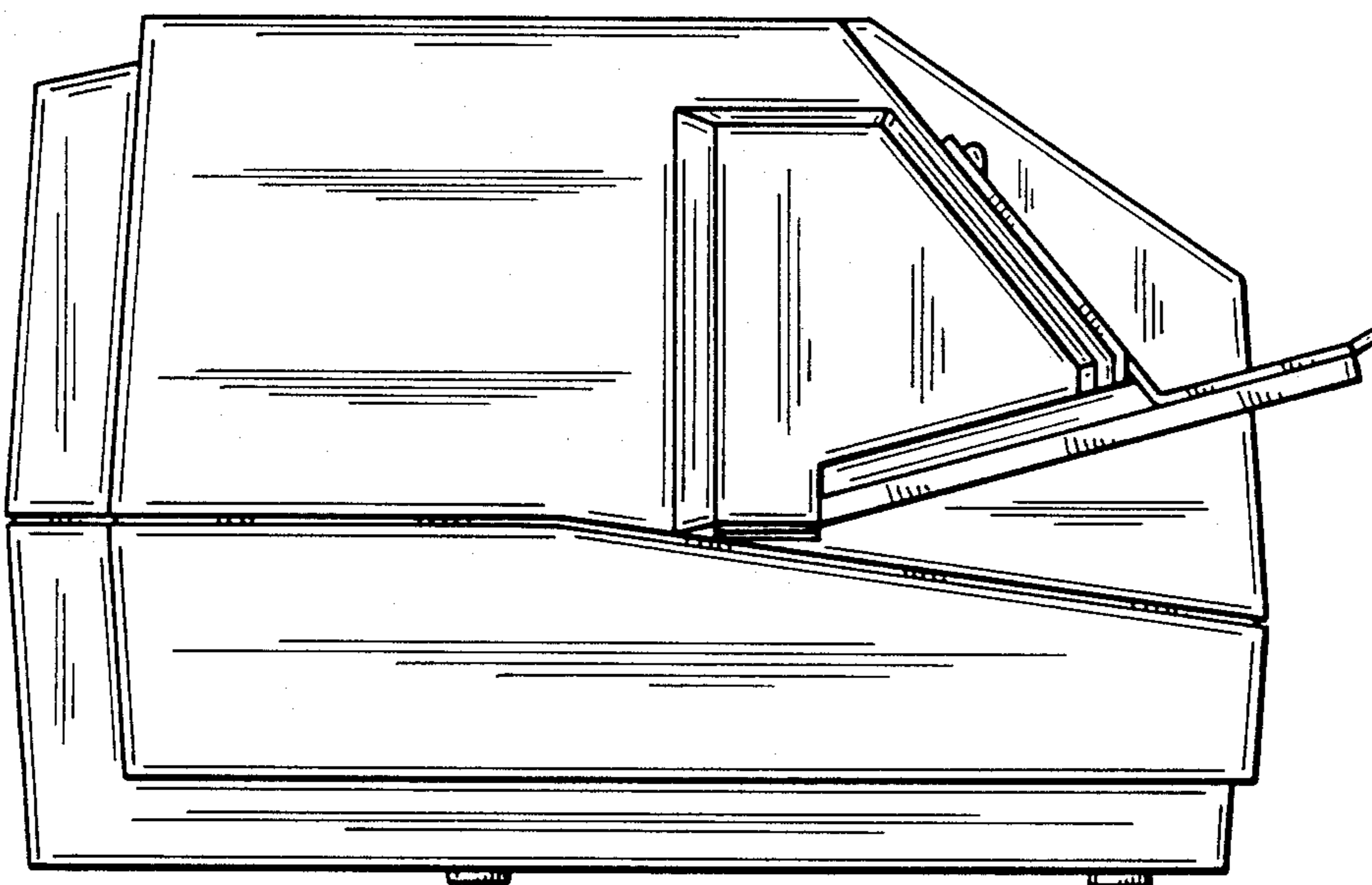

FIG\_6

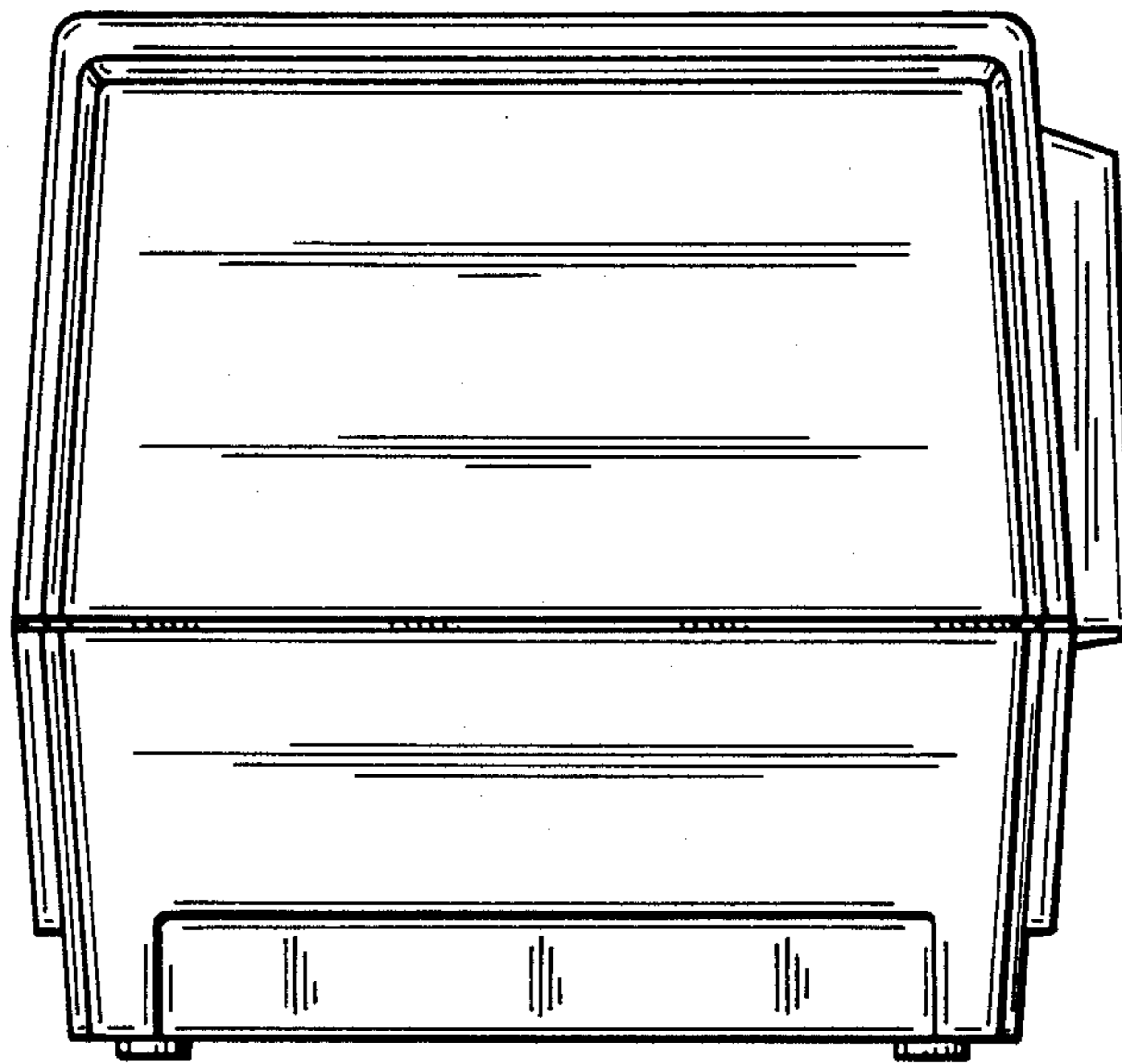

*FIG\_3*

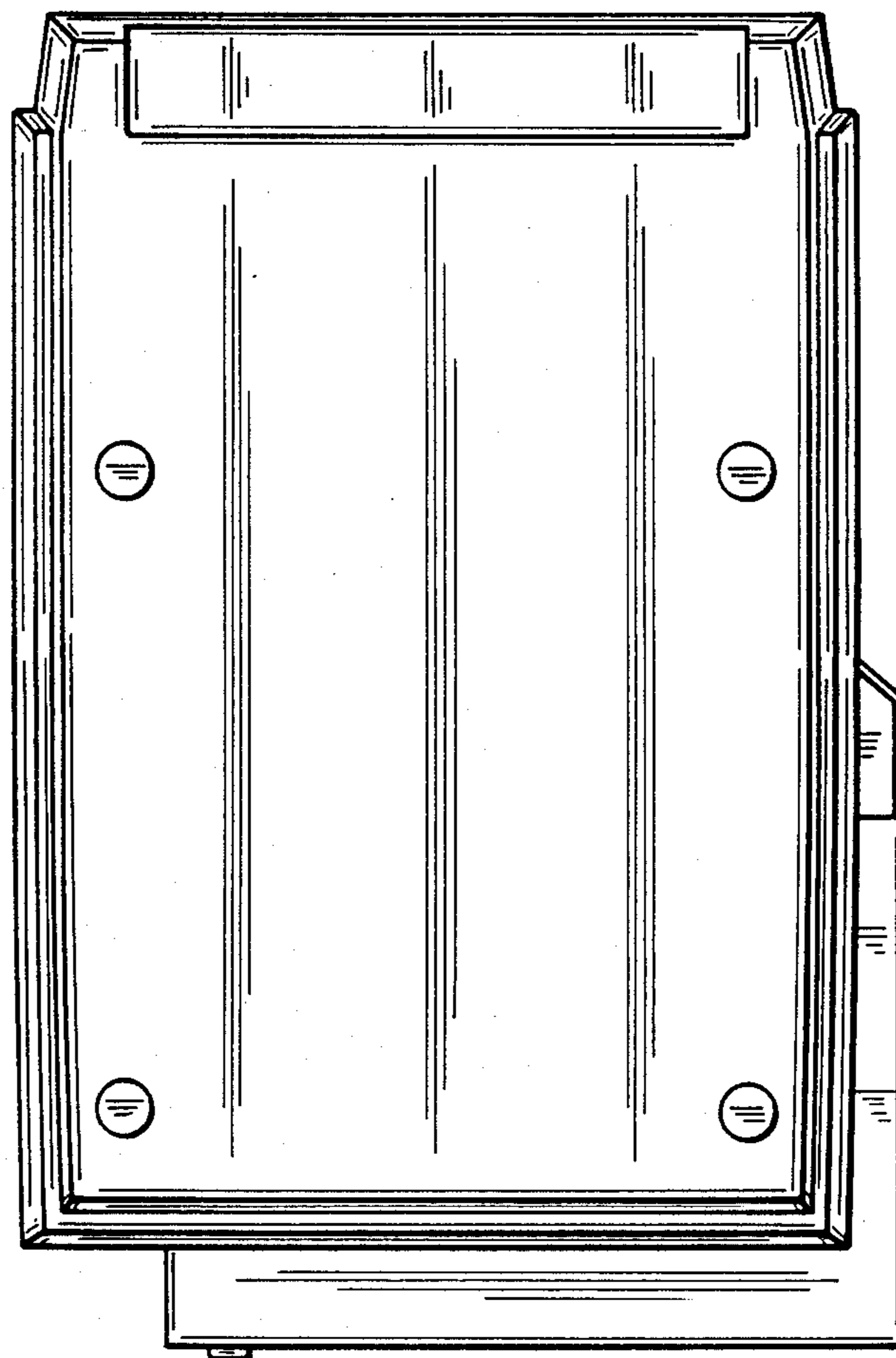

*FIG\_4*