

[54] PORTABLE INTERNAL COMBUSTION ENGINE AND TOOLS

[75] Inventors: **Katsumi Kiyooka, Warabi; Tetsuo Ueno, Higashiyamato; Keiko Iramina, Tachikawa; Hideko Inomata, Higashiyamato, all of Japan**

[73] Assignee: **Komatsu Zenoah Company, Tokyo, Japan**

[**] Term: **14 Years**

[21] Appl. No.: **819,357**

[22] Filed: **Jan. 16, 1986**

[30] Foreign Application Priority Data

Jul. 16, 1985 [JP] Japan 60-030056
Jul. 29, 1985 [JP] Japan 60-32067
Aug. 2, 1985 [JP] Japan 60-032807

[52] U.S. Cl. **D15/10**

[58] Field of Search D15/1, 10-12, D15/16, 28-29; D32/19, 25, 15-16; D8/70, 7, 62; 417/234; 239/346; 15/328

[56] References Cited

U.S. PATENT DOCUMENTS

D. 190,665	6/1961	Heiniger	D15/11
D. 209,735	1/1968	Smith	D32/25
D. 255,764	7/1980	Lombard	D15/12
D. 258,908	4/1981	Satoh	D15/11
D. 260,394	8/1981	Tuggle	D15/1
D. 274,620	7/1984	Murakami et al.	D15/1
D. 279,319	6/1985	McCloskey et al.	D32/15
D. 279,626	7/1985	McCloskey	D32/19
D. 285,848	9/1986	Iida et al.	D32/15
D. 286,927	11/1986	Aiyama	D32/15
D. 292,980	12/1987	Tomita et al.	D15/16

Primary Examiner—Bruce W. Dunkins
Assistant Examiner—Ruth Takemoto
Attorney, Agent, or Firm—Foley & Lardner, Schwartz, Jeffery, Schwaab, Mack, Blumenthal & Evans

[57] CLAIM

The ornamental design for a portable internal combustion engine and tools, as shown and described.

DESCRIPTION

FIG. 1 is a left side elevational view of a portable internal combustion engine, showing our new design; FIG. 2 is a right side elevational view thereof; FIG. 3 is a top plan view thereof; FIG. 4 is a bottom view thereof; FIG. 5 is a rear elevational view thereof; and FIG. 6 is a front elevational view thereof.

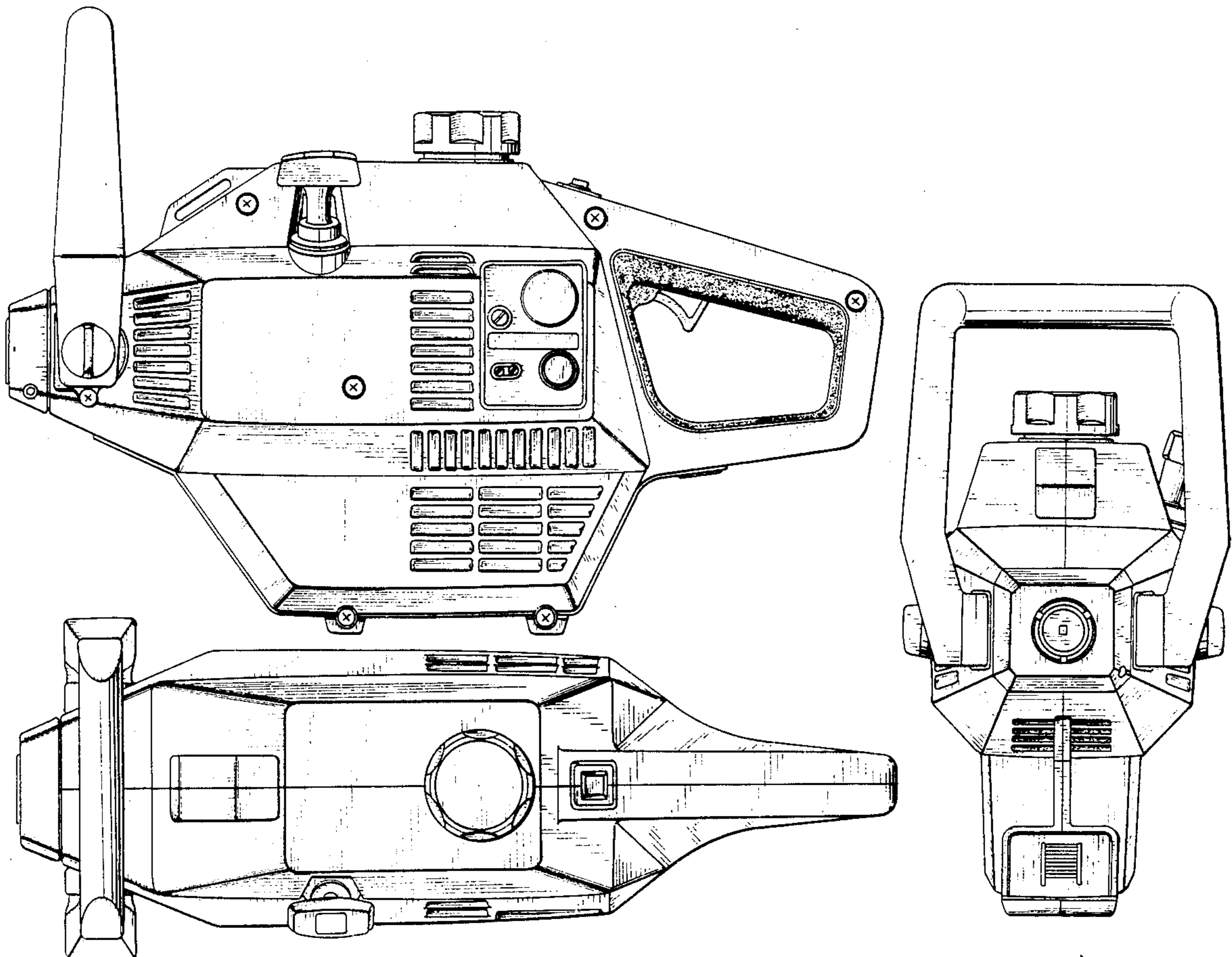

FIG. 1

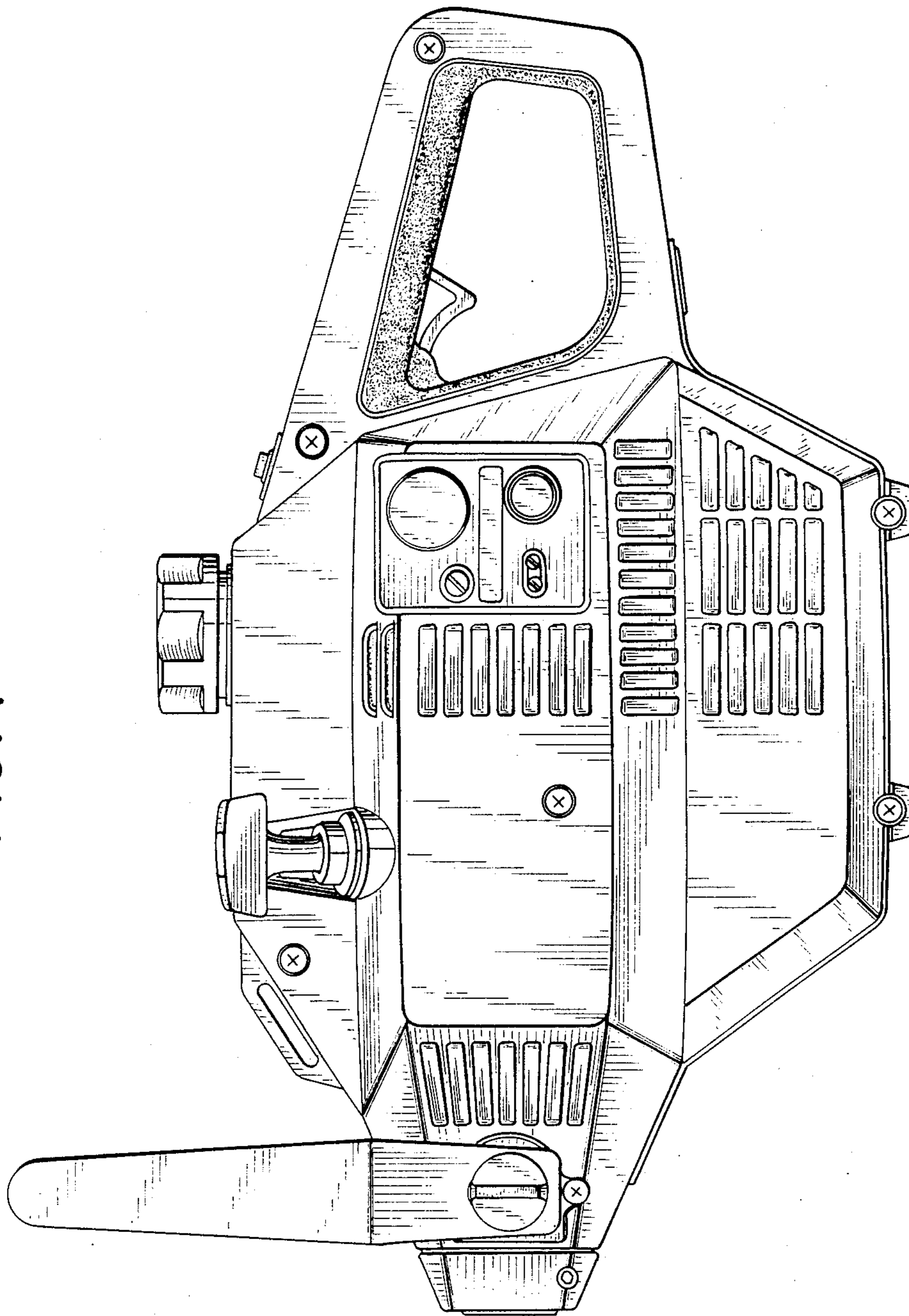

FIG. 2

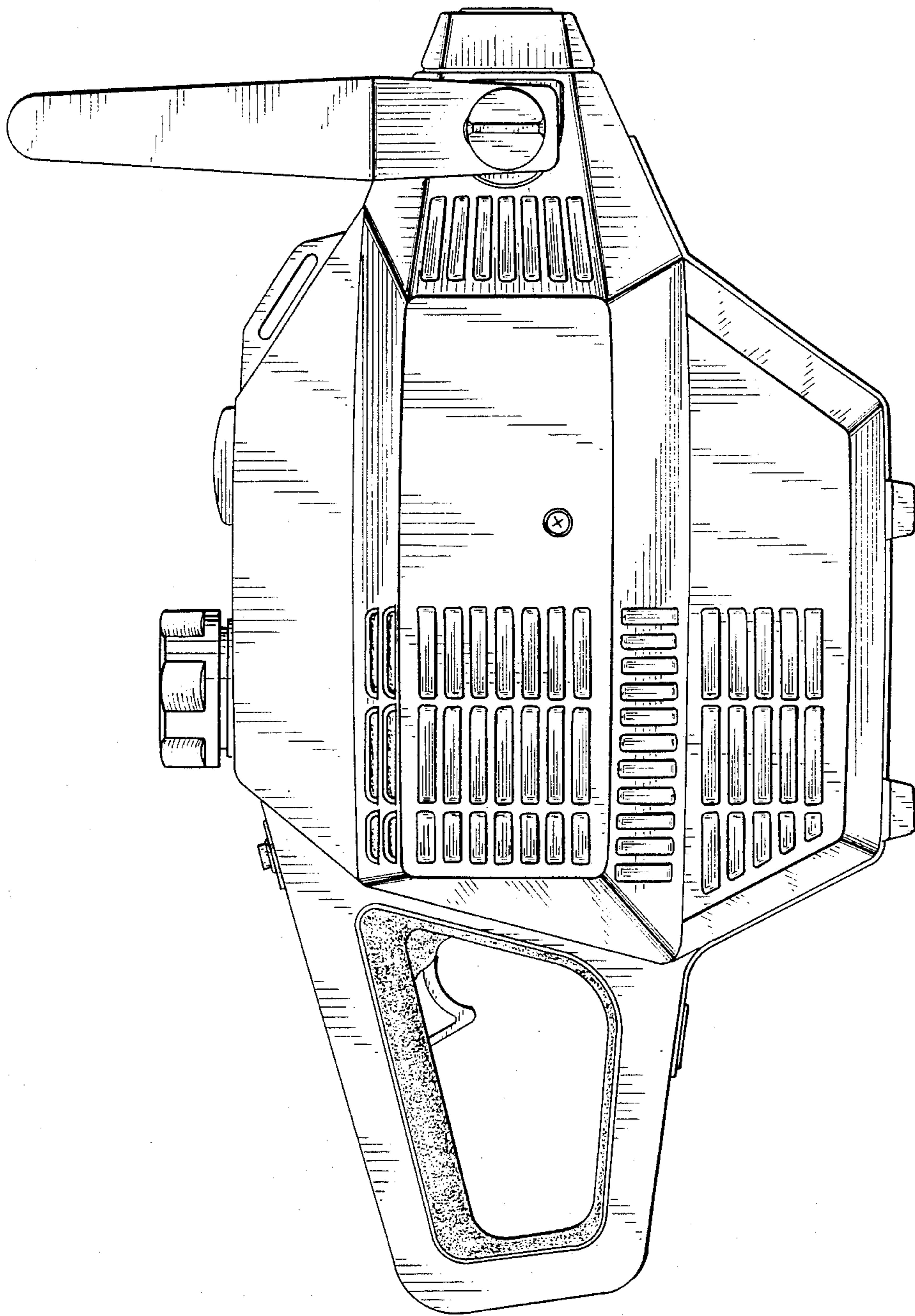

FIG. 3

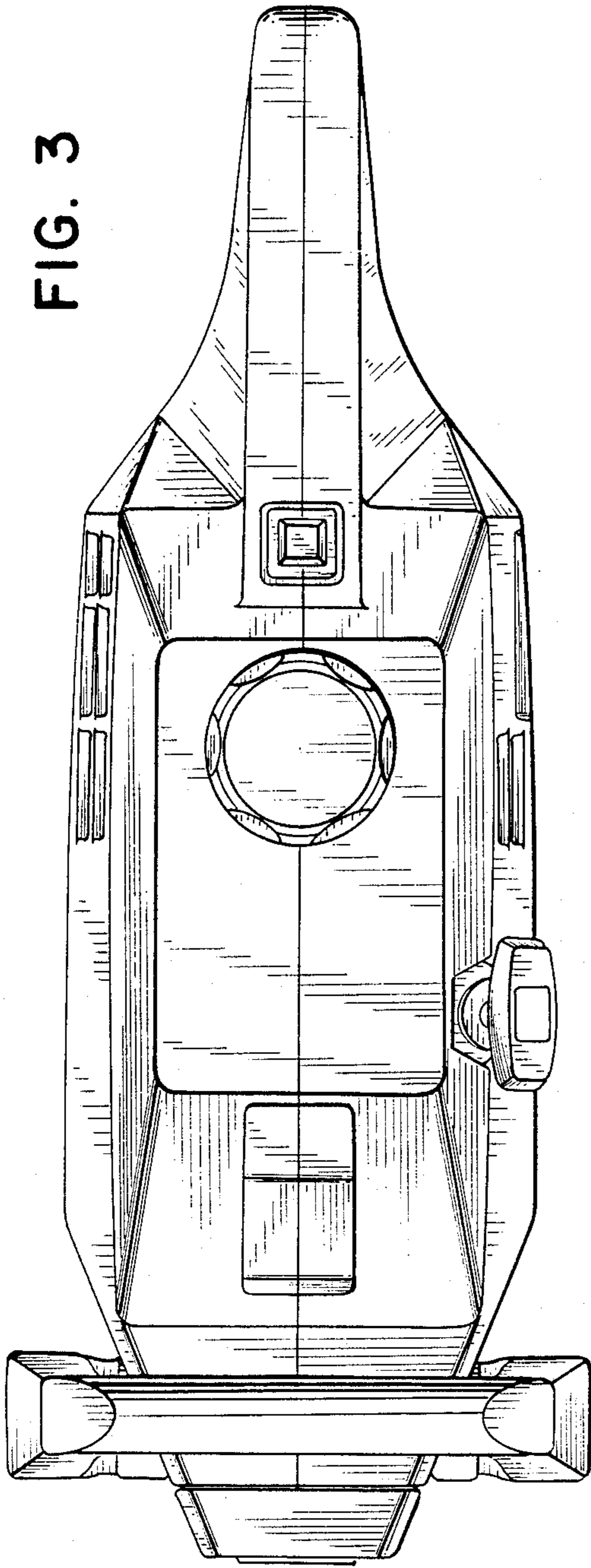

FIG. 4

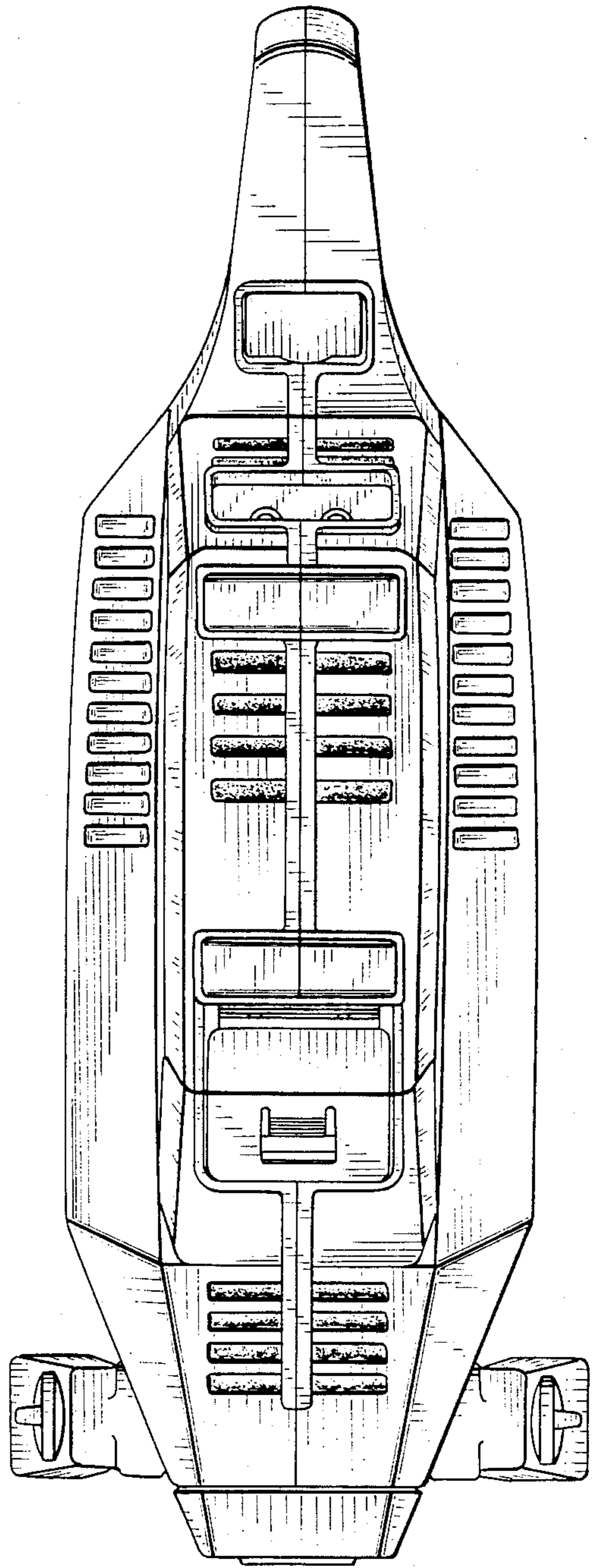

FIG. 6

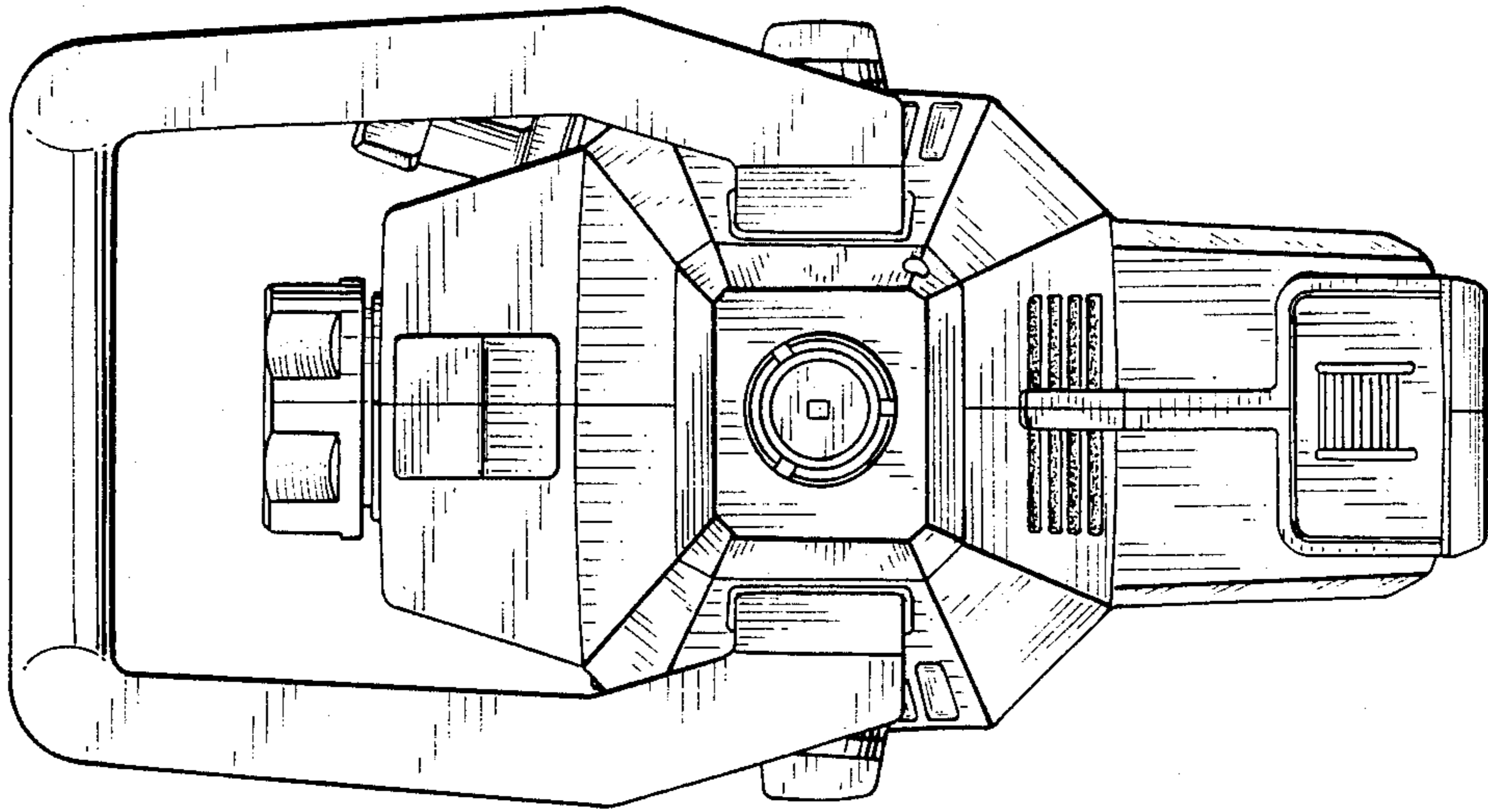

FIG. 5

