

United States Patent [19]

Kamlukin et al.

[11] Patent Number: **Des. 303,804**

[45] Date of Patent: **** Oct. 3, 1989**

[54] **SELF-PROPELLED RIDING TRACTOR**

[75] Inventors: **Igor Kamlukin; John F. Brackin**, both of Mequon; **Edward Freier, Jr.**, Port Washington, all of Wis.

[73] Assignee: **Simplicity Manufacturing, Inc.**, Port Washington, Wis.

[**] Term: **14 Years**

[21] Appl. No.: **47,705**

[22] Filed: **May 7, 1987**

[52] U.S. Cl. **D15/23**

[58] Field of Search **D15/10, 15, 23, 25, D15/30-33; 56/244, 249, 255-257, 264, 13.3-13.4, DIG. 22**

[56] **References Cited**

U.S. PATENT DOCUMENTS

- D. 215,110 9/1969 Schreckengost D15/15
- D. 243,270 2/1977 Ehrlin et al. D15/15
- D. 248,655 7/1978 Klein D15/15

- D. 284,968 8/1986 Watanabe et al. D15/15
- D. 298,539 11/1988 Katoh et al. D15/23

Primary Examiner—Bruce W. Dunkins
Assistant Examiner—Ruth Takemoto
Attorney, Agent, or Firm—Michael D. Rehtin; Philip P. Mann

[57] **CLAIM**

The ornamental design for a self-propelled riding tractor, as shown.

DESCRIPTION

FIG. 1 is a left side elevation view of self-propelled riding tractor showing our new design; FIG. 2 is a top plan view thereof; FIG. 3 is a right side elevational view thereof; FIG. 4 is a bottom plan view thereof; FIG. 5 is a front elevational view thereof; FIG. 6 is a rear elevational view thereof; and FIG. 7 is a top, front and side perspective view thereof. The cross hatch pattern shown in FIGS. 1 and 3 is understood to repeat throughout the indicated area as shown in FIG. 7.

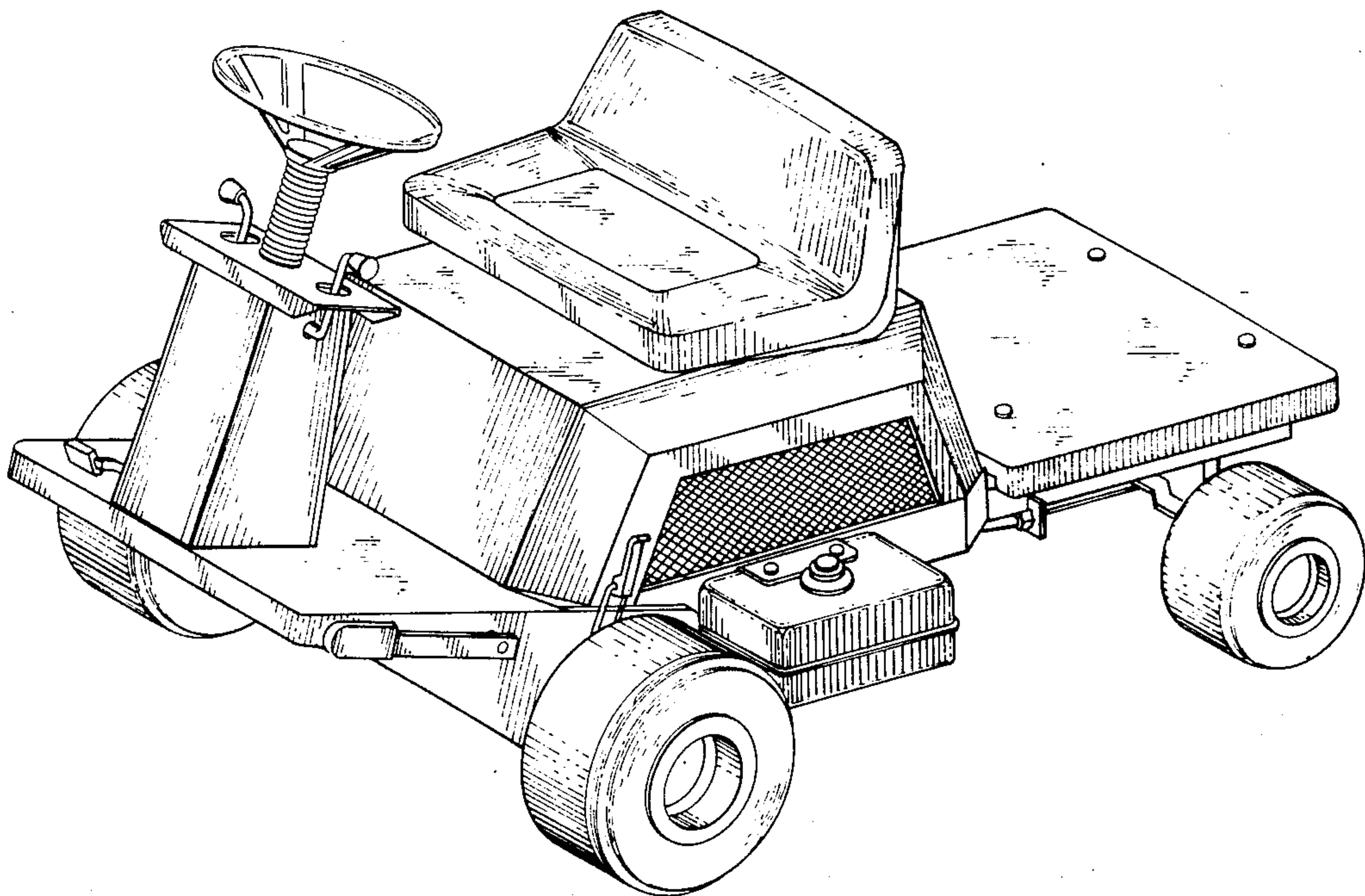

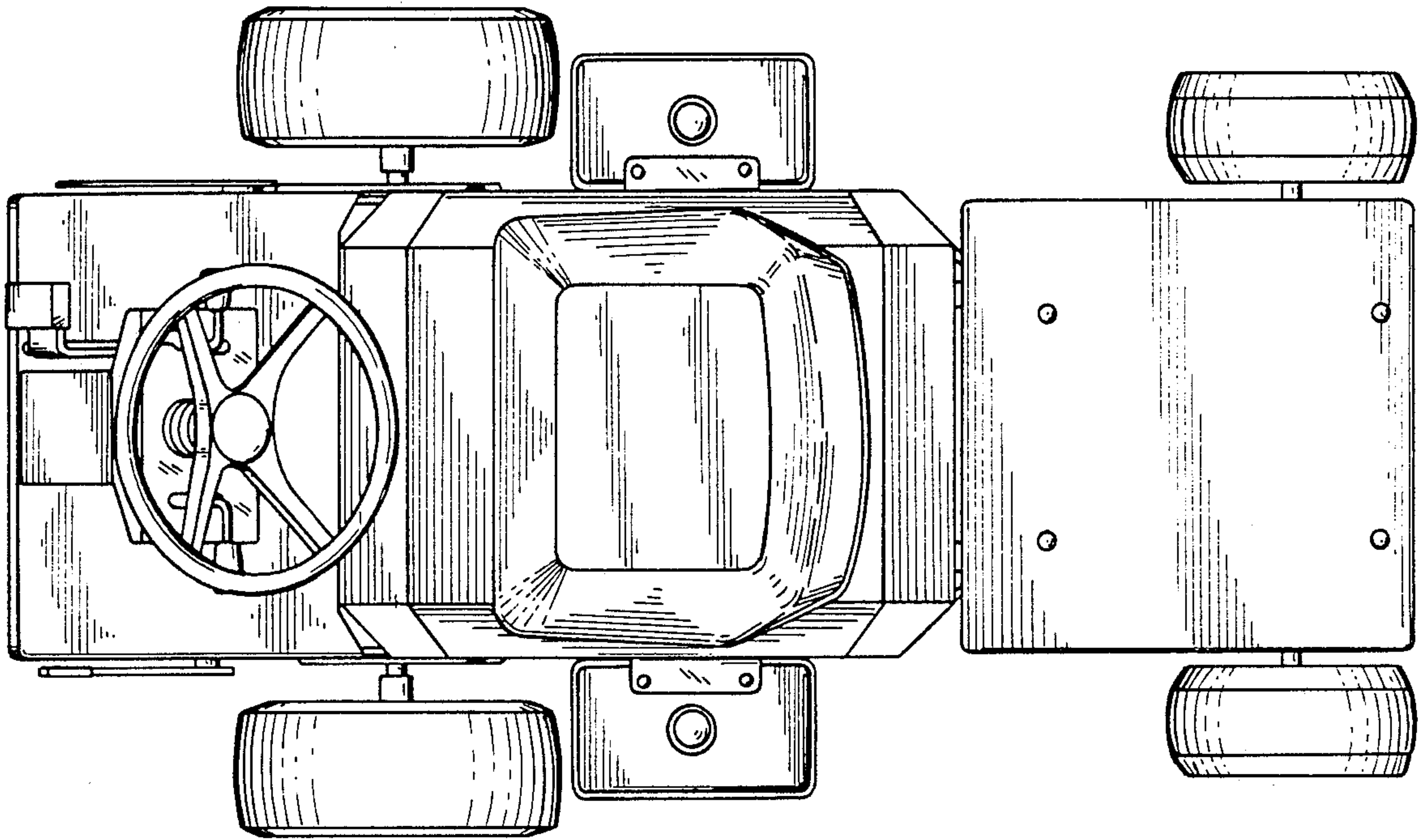

FIG. 2

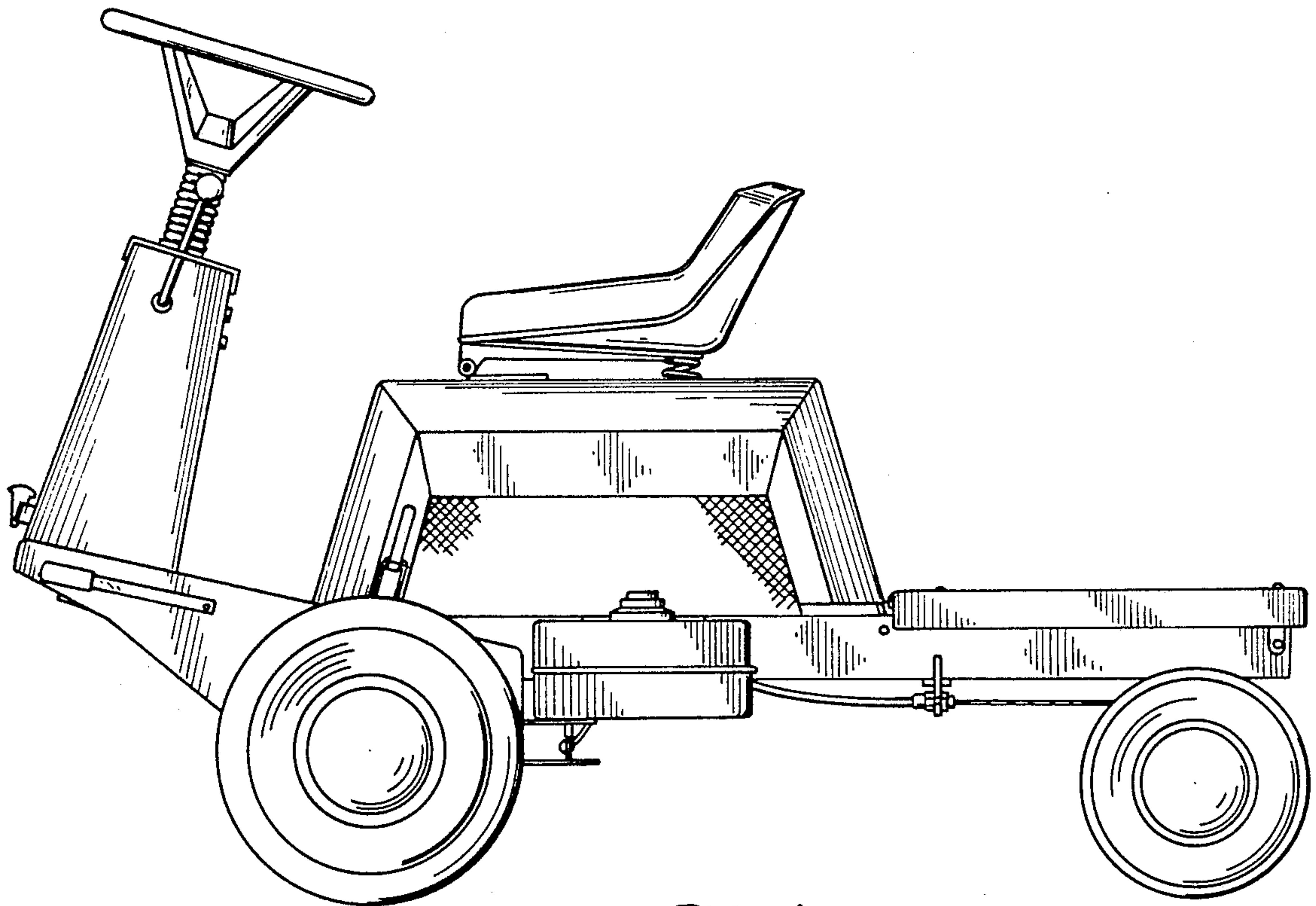

FIG. 1

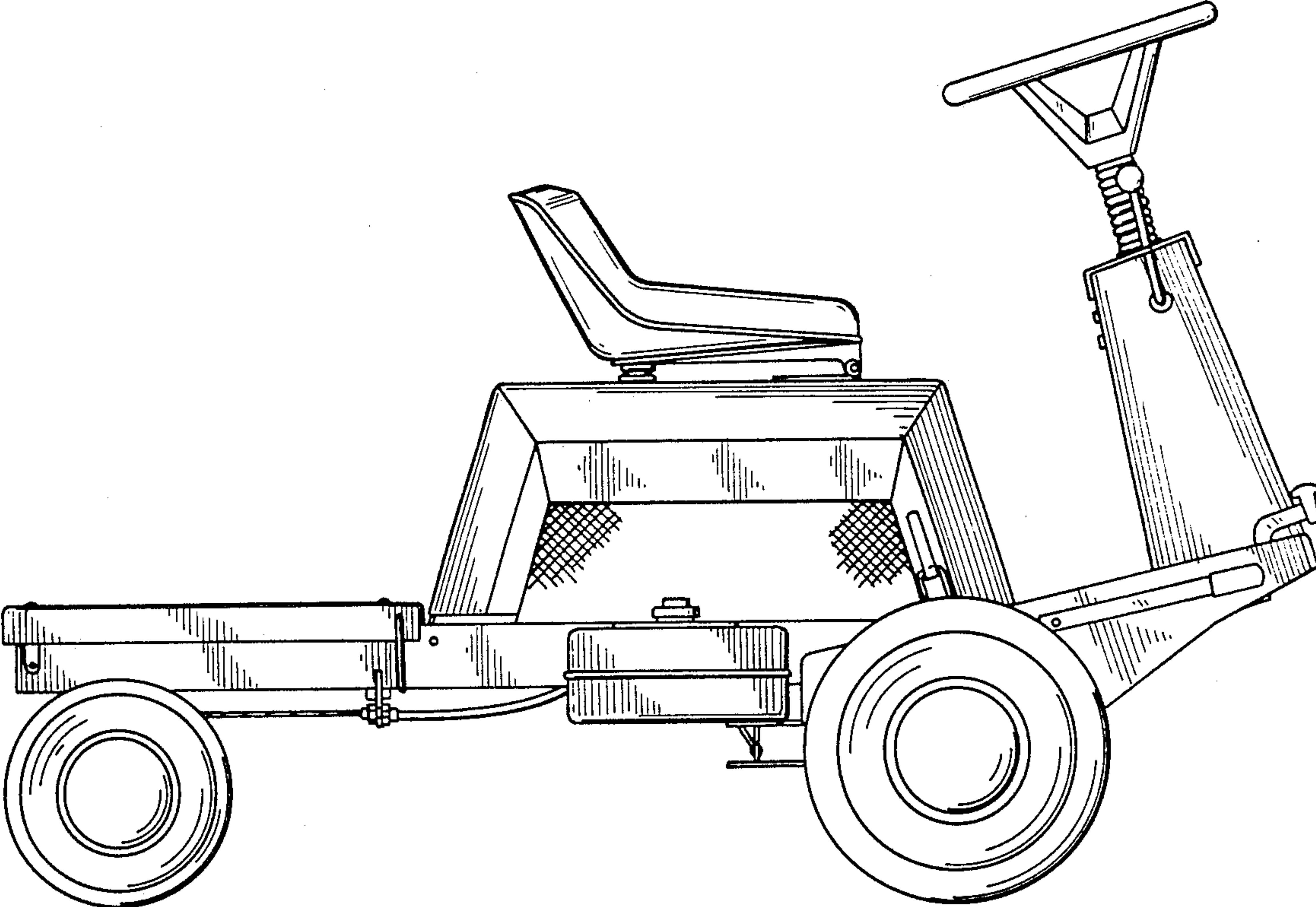

FIG. 3

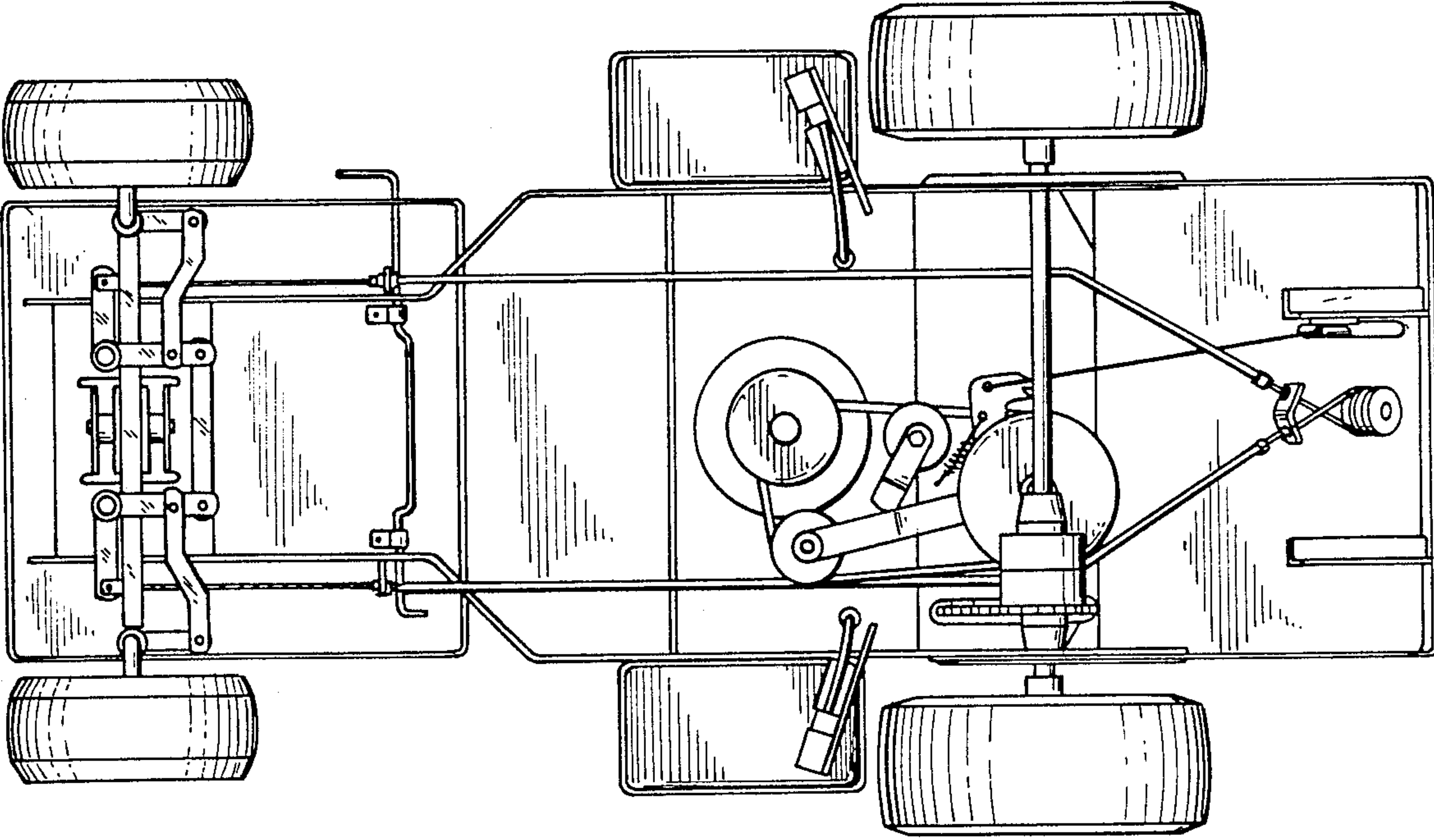

FIG. 4

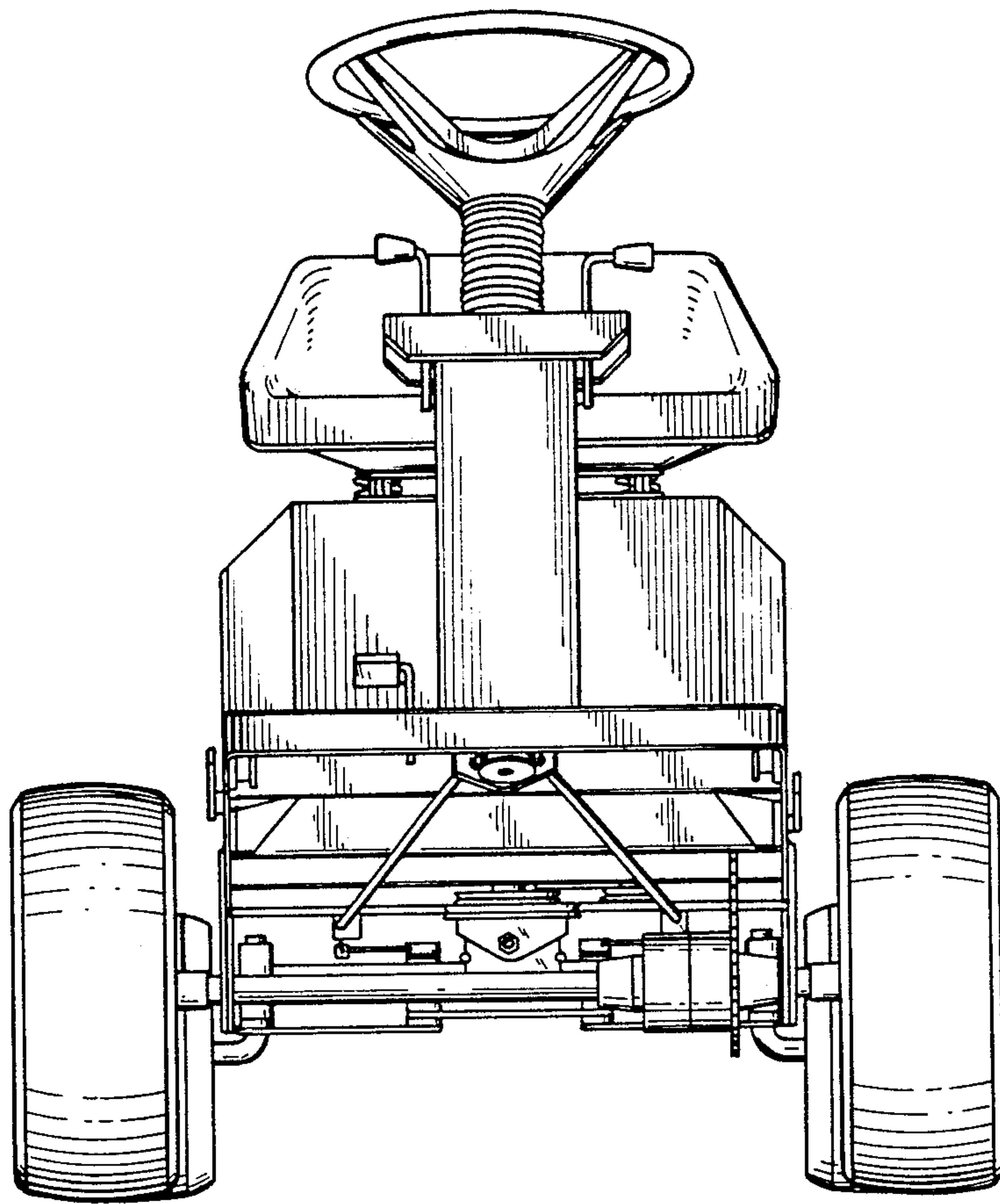

FIG. 5

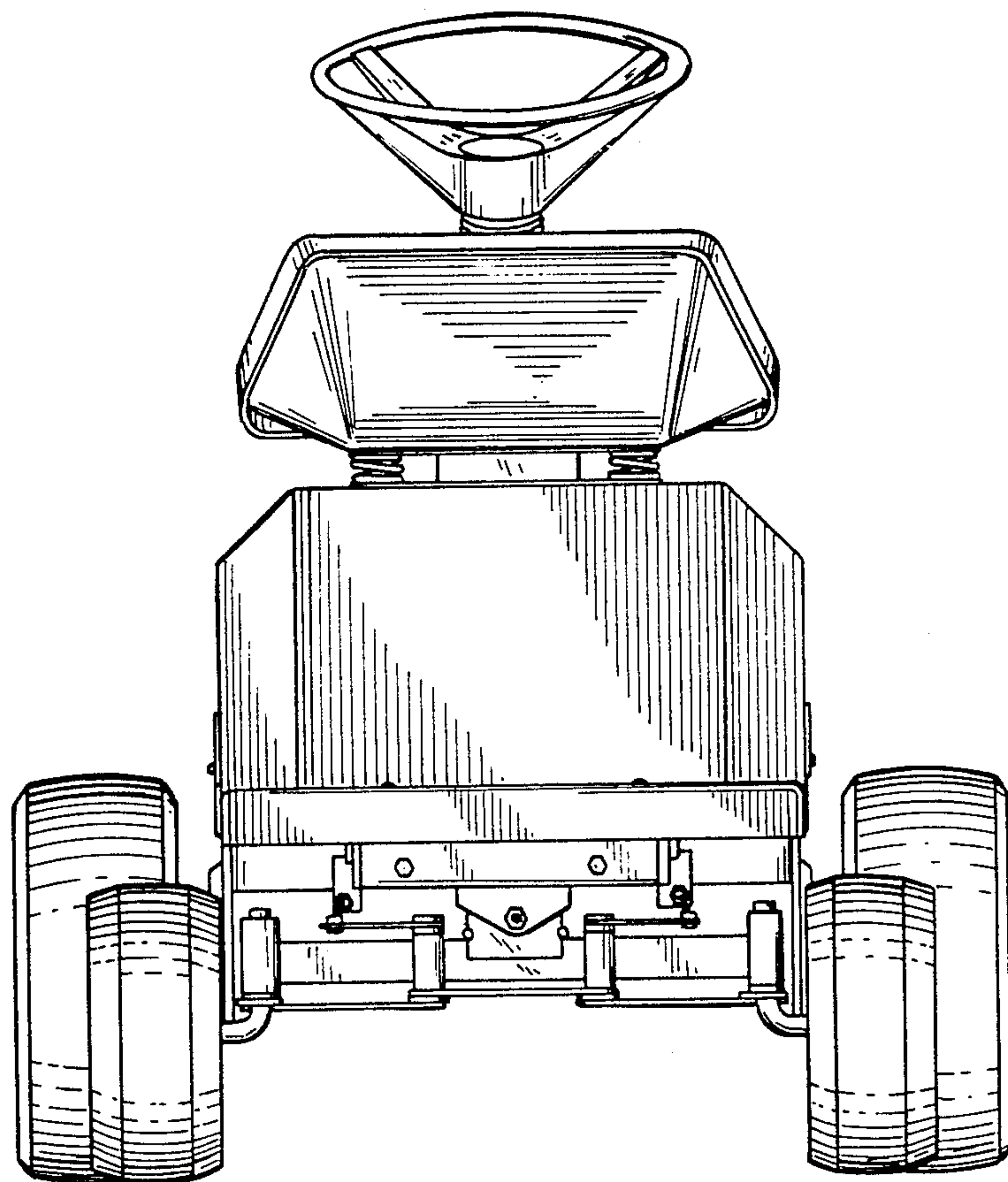

FIG. 6

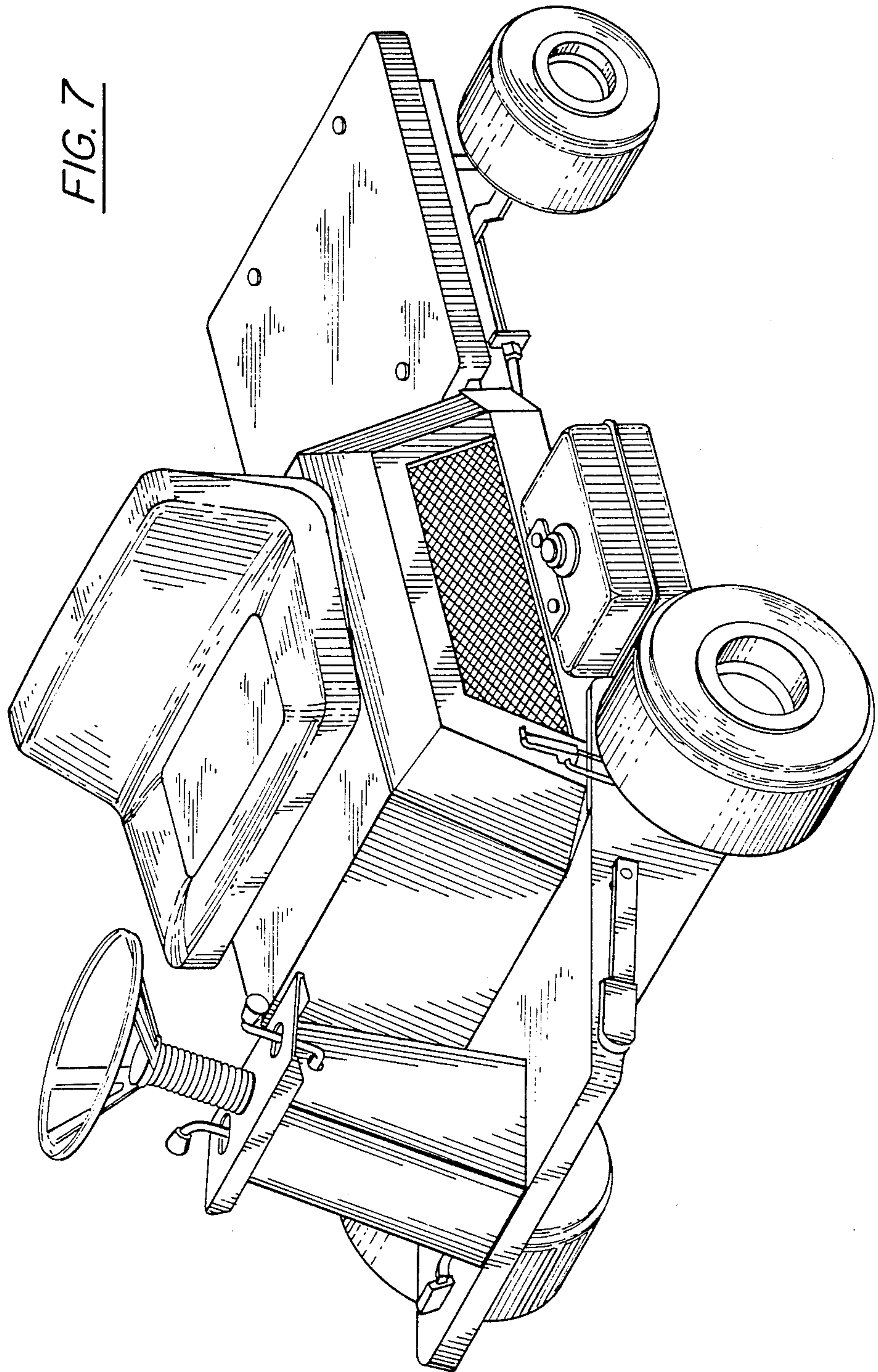

FIG. 7