

[54] **DATA INPUT UNIT FOR A SEWING MACHINE WITH A TOUCH ENTRY PAD**

[75] **Inventors: Nobuyuki Kondoh; Yoshinori Abe, both of Kamakura; Iwao Yamane, Nagoya, all of Japan**

[73] **Assignee: Mitsubishi Denki Kabushiki Kaisha, Tokyo, Japan**

[**] **Term: 14 Years**

[21] **Appl. No.: 883,809**

[22] **Filed: Jul. 9, 1986**

[30] **Foreign Application Priority Data**

Jan. 10, 1986 [JP] Japan 401/86
 Feb. 4, 1986 [JP] Japan 3712/86
 Feb. 4, 1986 [JP] Japan 3713/86

[52] **U.S. Cl. D14/100**

[58] **Field of Search D14/100, 105, 106, 107, D14/113, 114, 115; D18/1, 7, 11, 12; 112/455, 456, 457, 458; 364/189, 130; 340/706, 712, 700; 235/145 R, 145 A; 341/22, 23**

[56] **References Cited**

U.S. PATENT DOCUMENTS

D. 258,221 2/1981 Shimasaki D18/7
 D. 279,983 8/1985 Grimes D14/100
 D. 282,843 3/1986 Kurihara D18/7 X
 D. 284,869 7/1986 Kurihara D14/100 X
 D. 286,045 10/1986 McGarvey et al. D14/100
 4,446,520 5/1984 Shigeta et al. 112/456 X
 4,697,244 9/1987 Murakami et al. 340/706 X
 4,703,432 10/1987 Müller 112/457 X
 4,720,781 1/1988 Crossland et al. 340/700 X

Primary Examiner—Susan J. Lucas

Assistant Examiner—Freda S. Nunn
Attorney, Agent, or Firm—Sughrue, Mion, Zinn, Macpeak & Seas

[57] **CLAIM**

The ornamental design for a data input device for a sewing machine, as shown and described.

DESCRIPTION

FIG. 1 is a front, top and right side perspective view of a data input unit for a sewing machine with a touch entry pad showing our new design;

FIG. 2 is a front, top and right side perspective view thereof, with the liquid crystal indicator in a raised condition;

FIG. 3 is a front elevational view thereof;

FIG. 4 is a rear elevational view thereof;

FIG. 5 is a left side elevational view thereof;

FIG. 6 is a right side elevational view thereof;

FIG. 7 is a top plan view thereof;

FIG. 8 is a bottom plan view thereof;

FIG. 9 is a front, top and right side perspective view of a data input unit for a sewing machine with a touch entry pad showing a second embodiment of our new design wherein the sole difference resides in the top rear portion thereof; and

FIG. 10 is a front, top and right side perspective view of FIG. 9 with the liquid crystal indicator and adjacent cover in a raised condition;

FIG. 11 is a front, top and right side perspective view of the data input unit for a sewing machine with a touch entry pad showing a third embodiment of our new design; wherein the sole difference resides in the top, rear portion thereof; and

FIG. 12 is a front, top and right side perspective view of FIG. 11, with the liquid crystal indicator and adjacent cover in a raised condition.

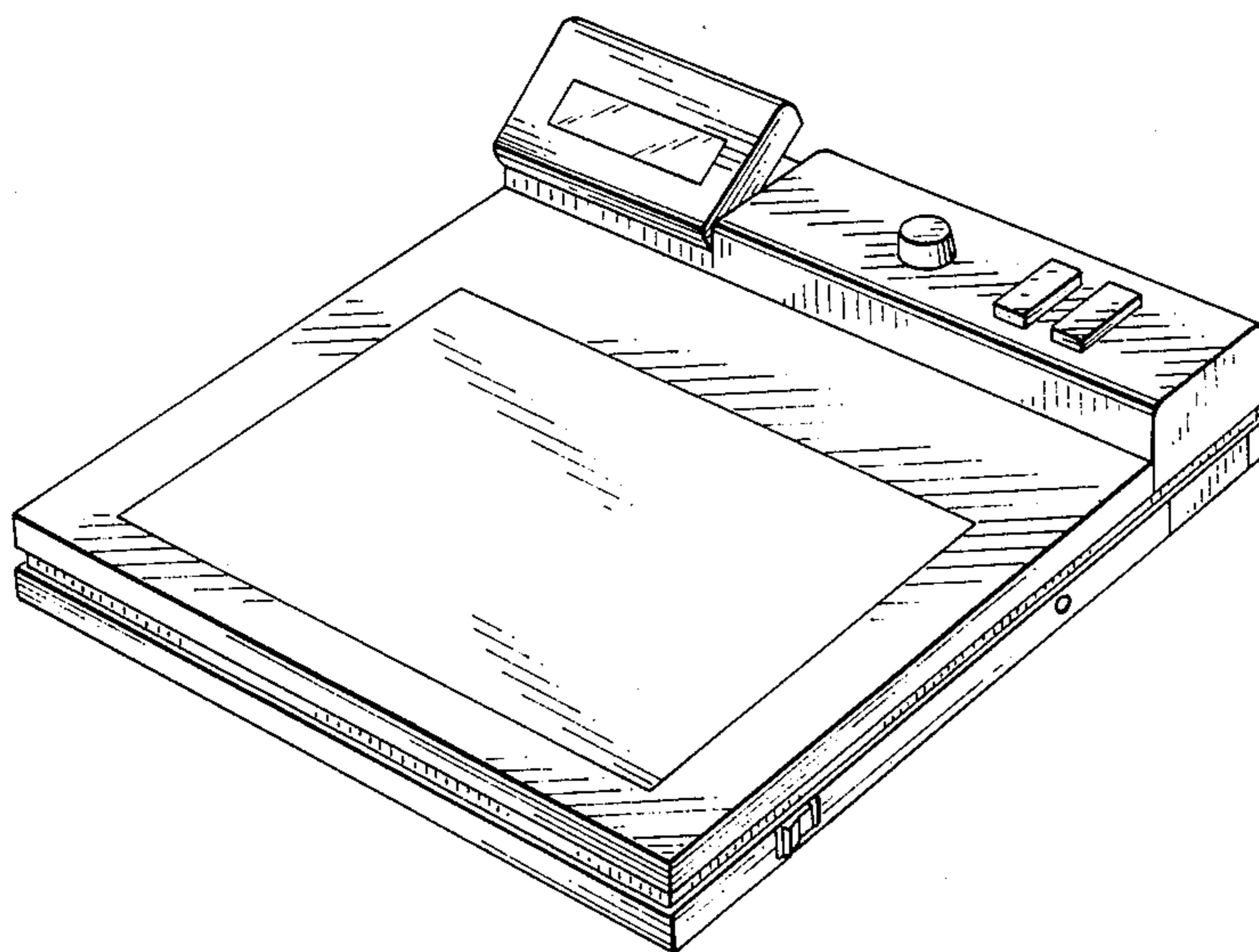

FIG. 1

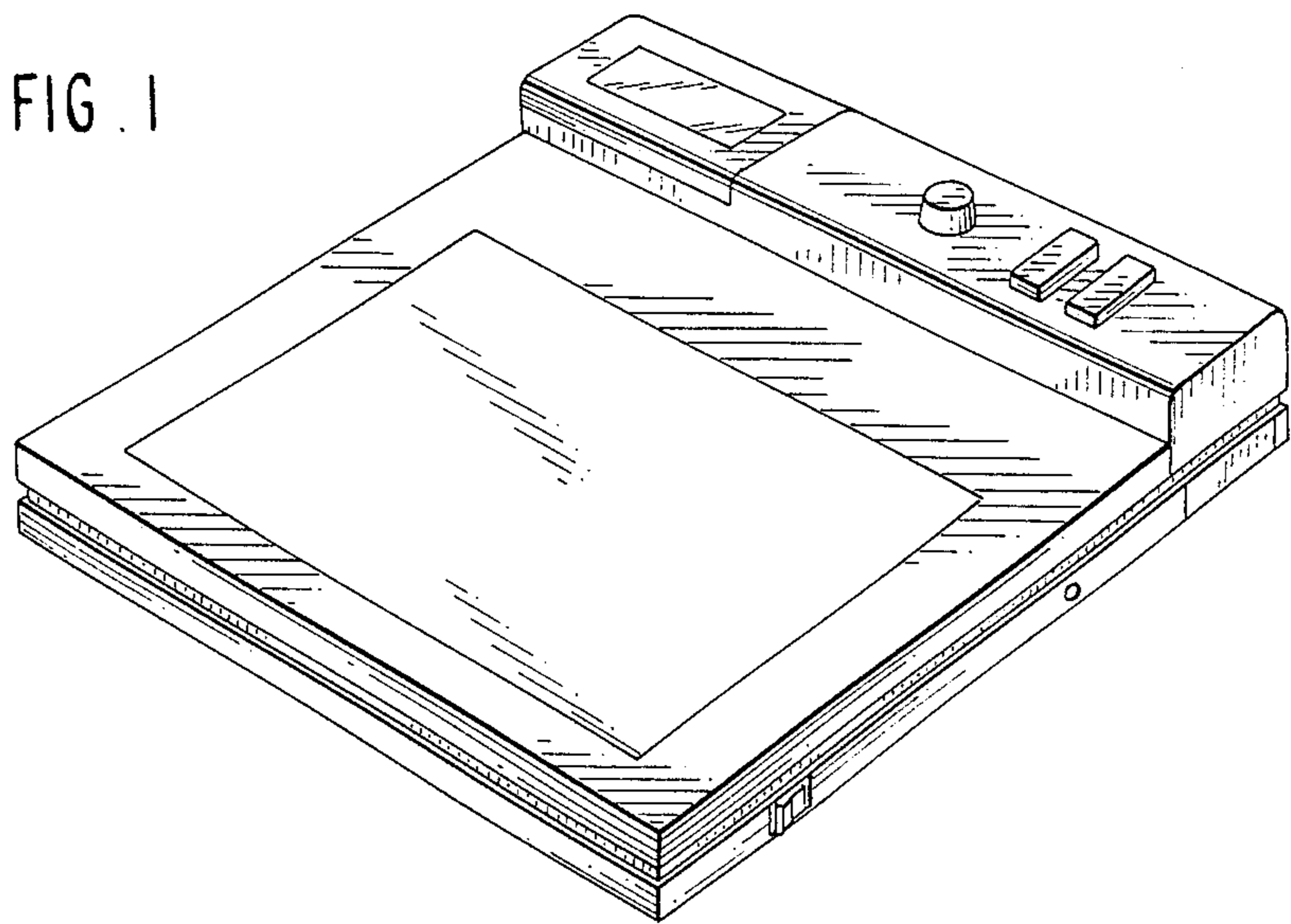

FIG. 2

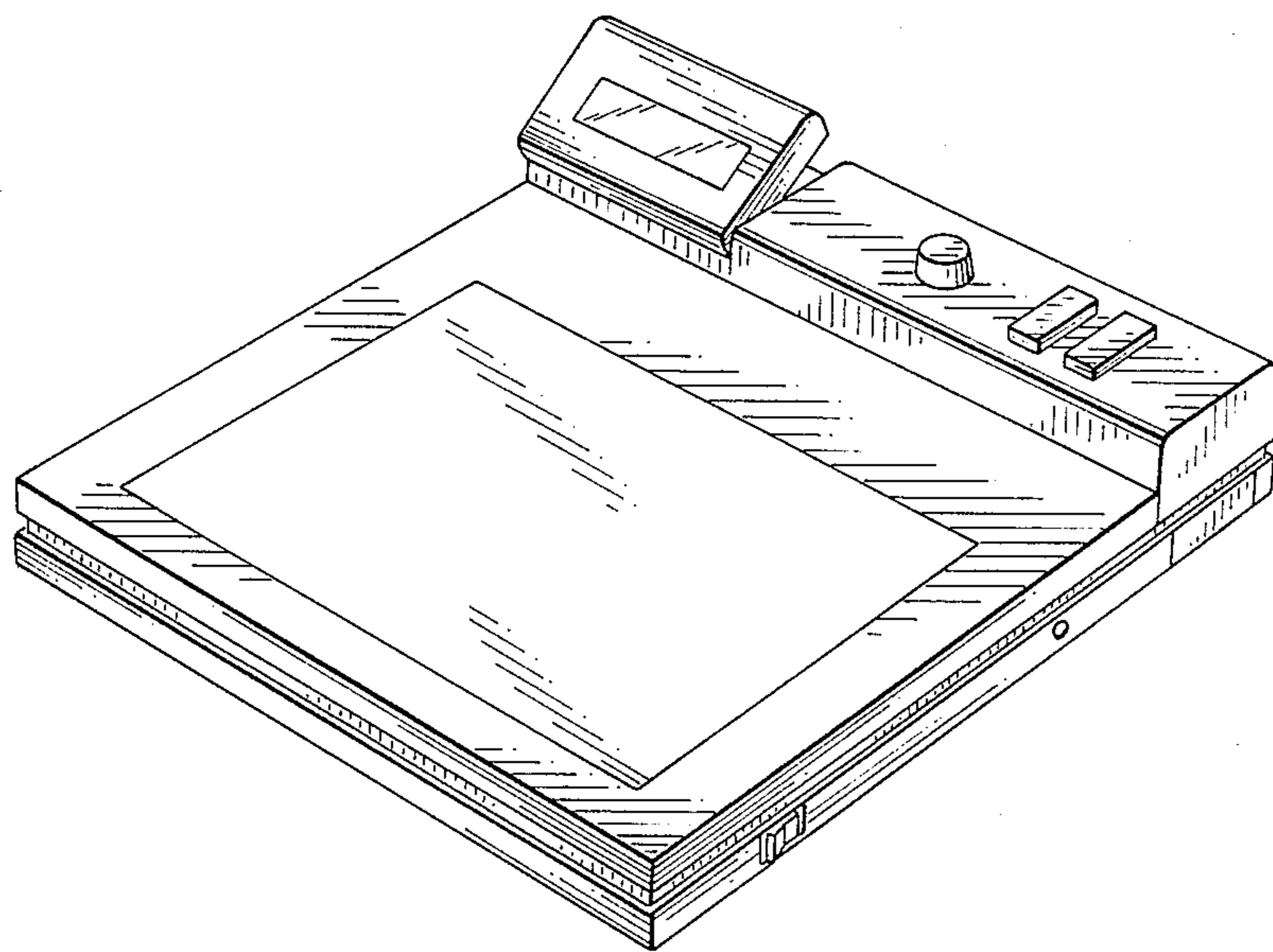

FIG. 3

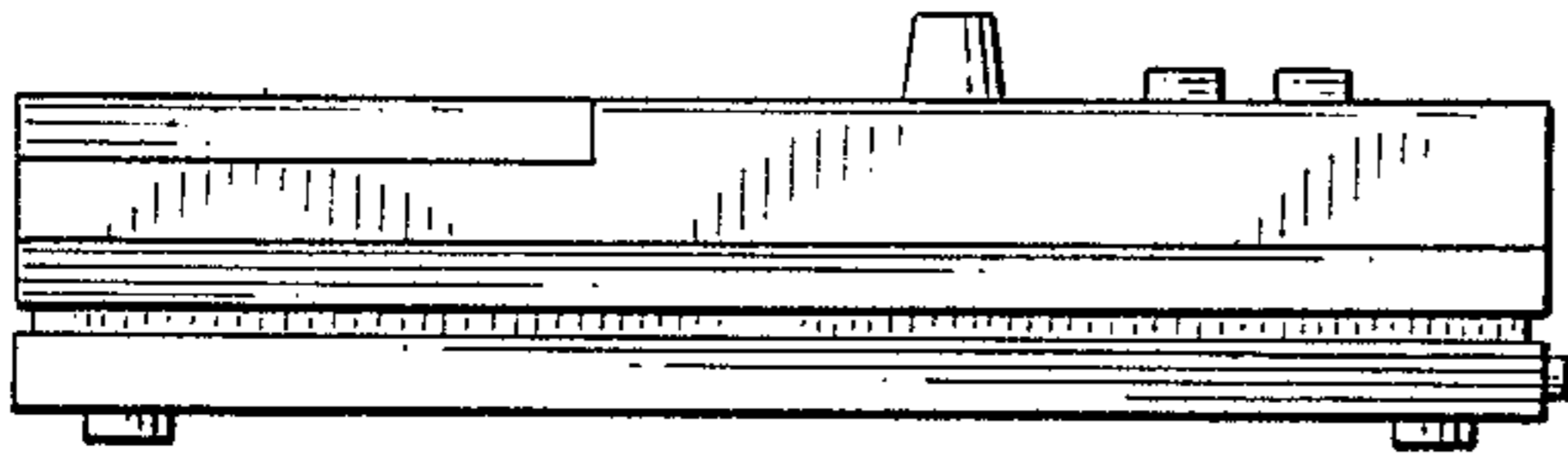

FIG. 4

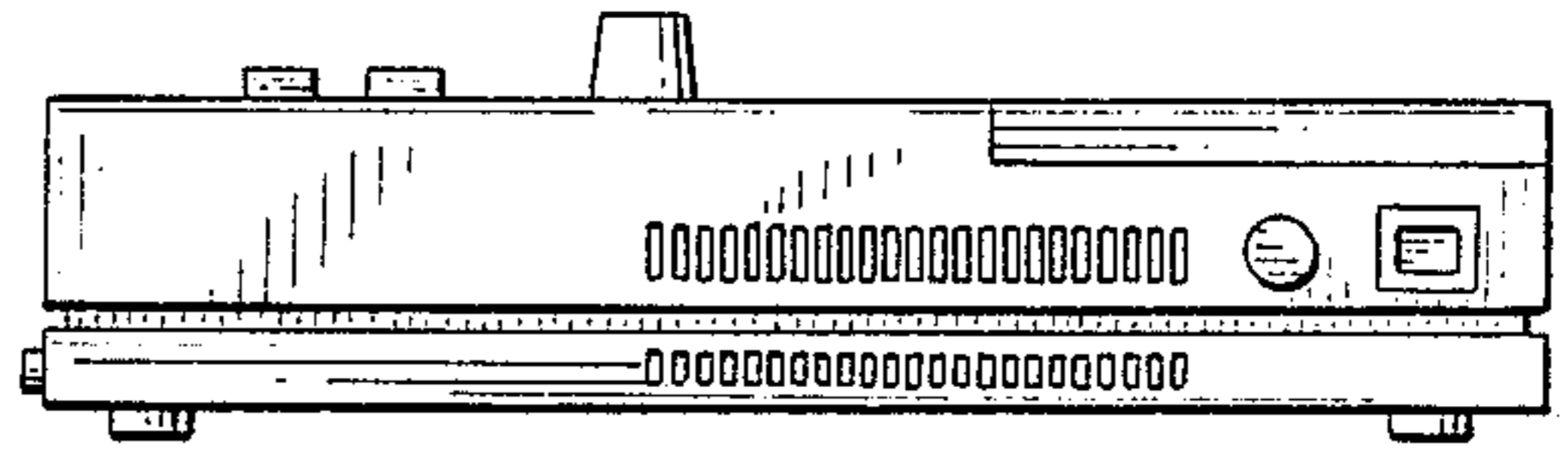

FIG. 5

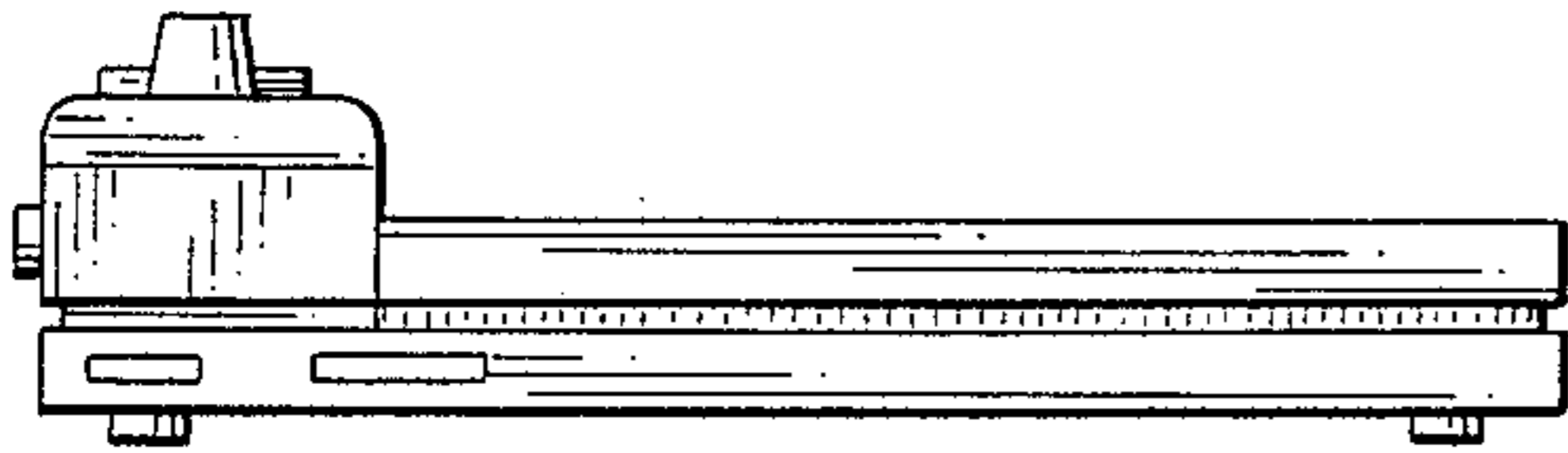

FIG. 6

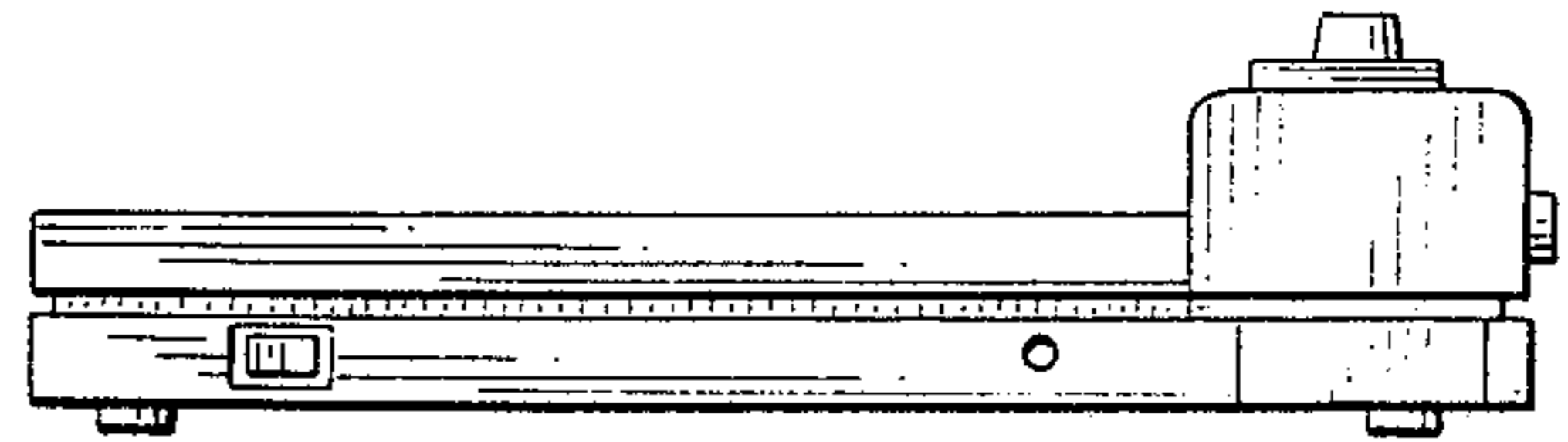

FIG. 7

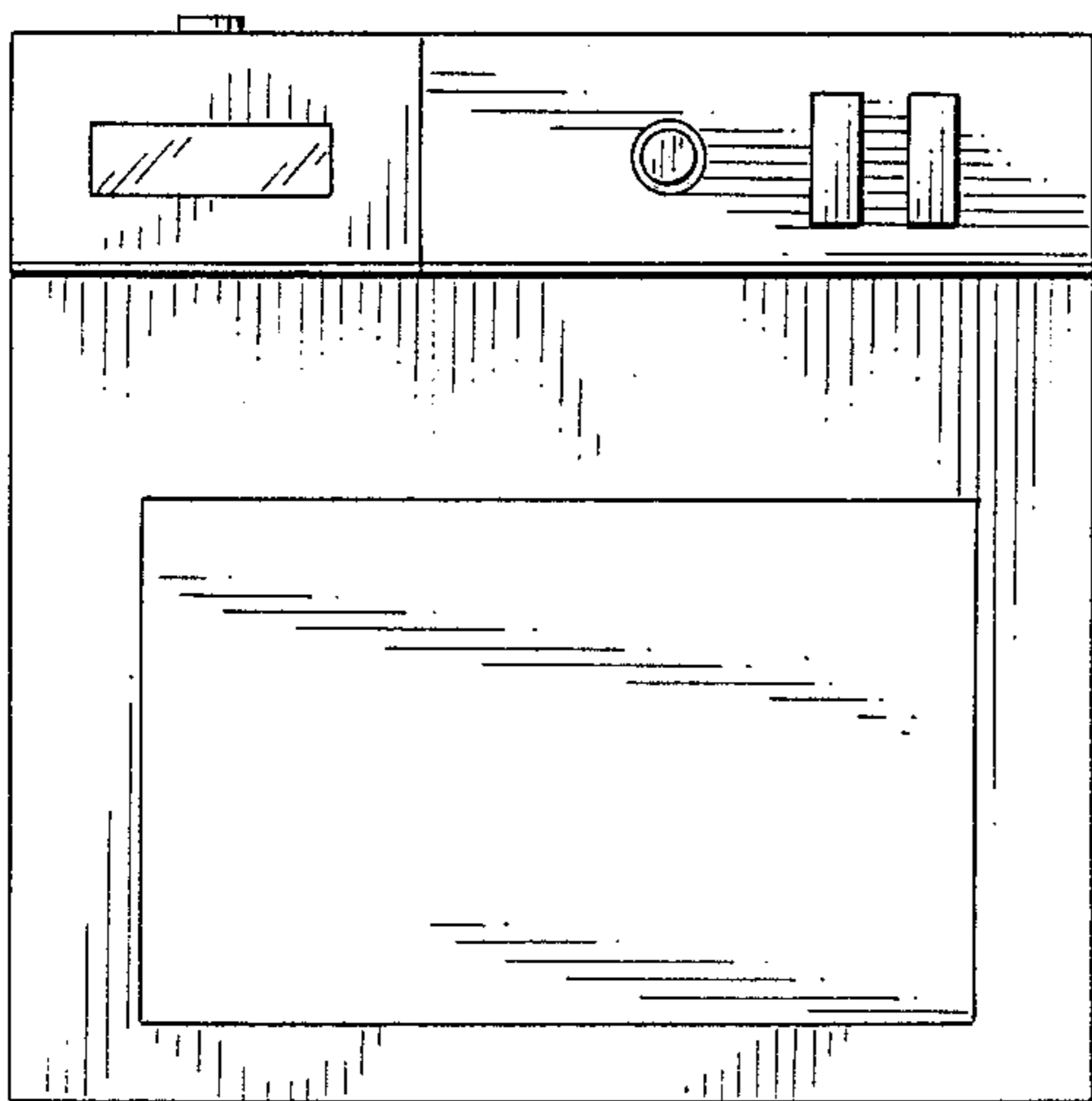

FIG. 8

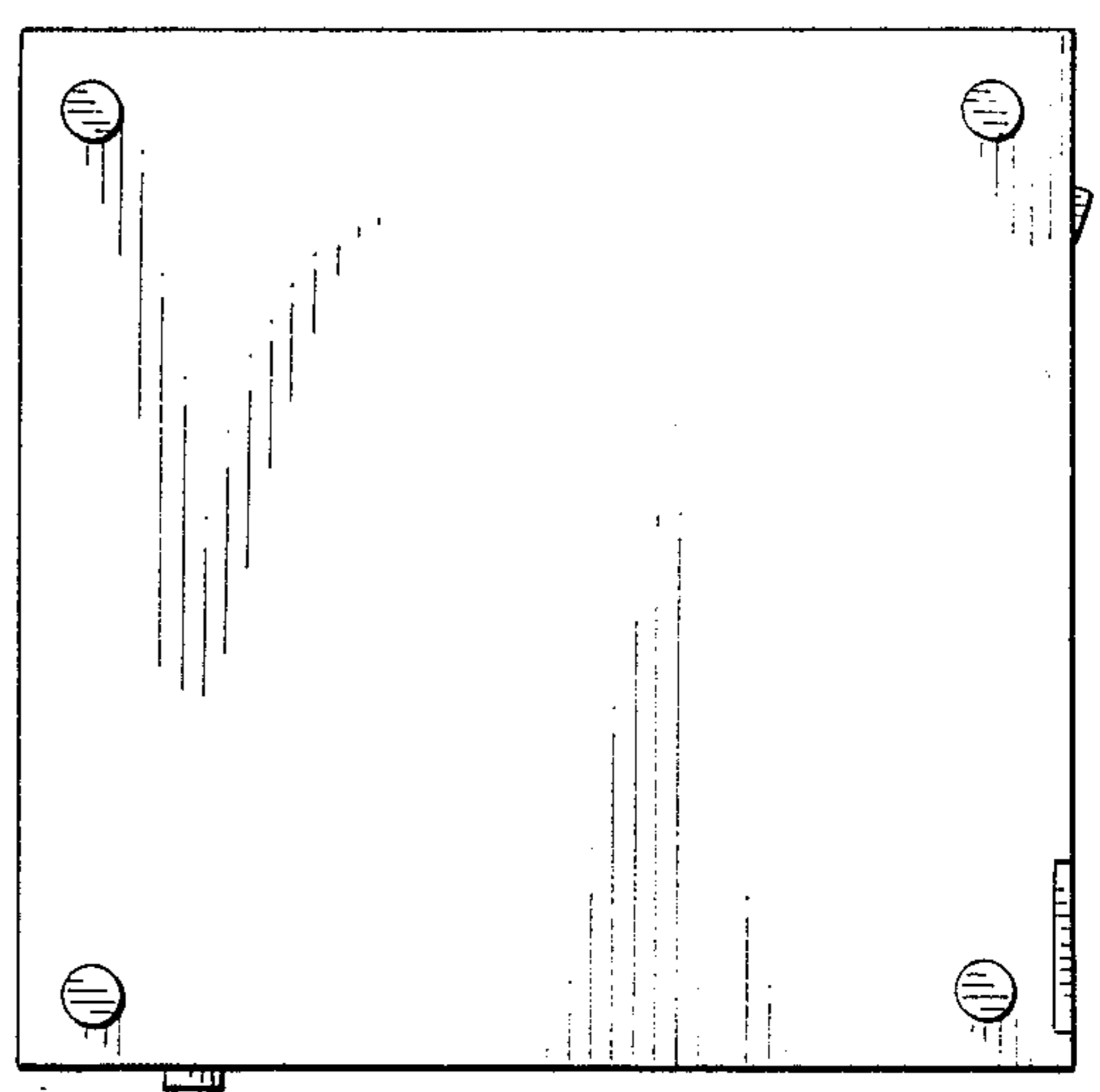

FIG. 9

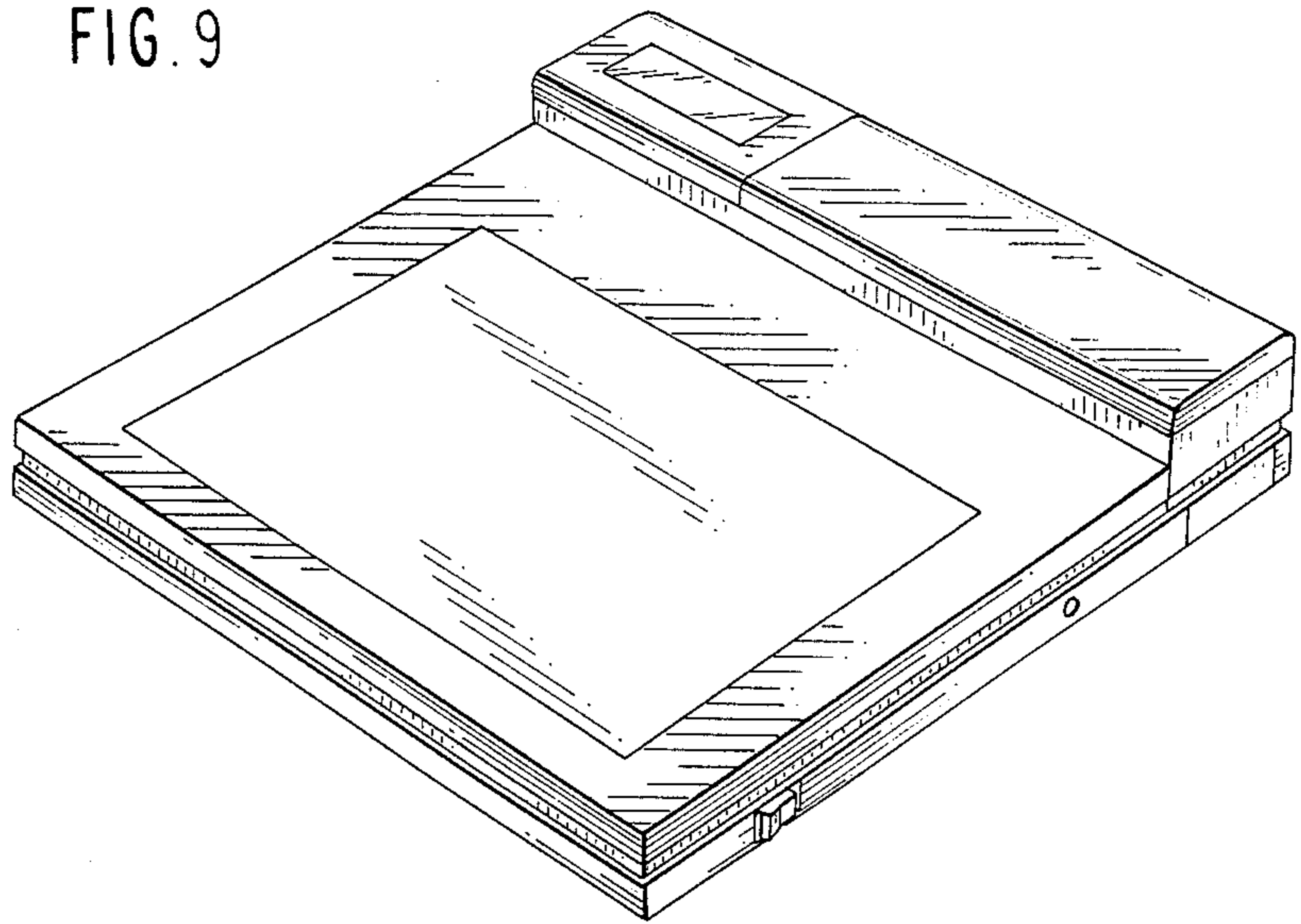

FIG. 10

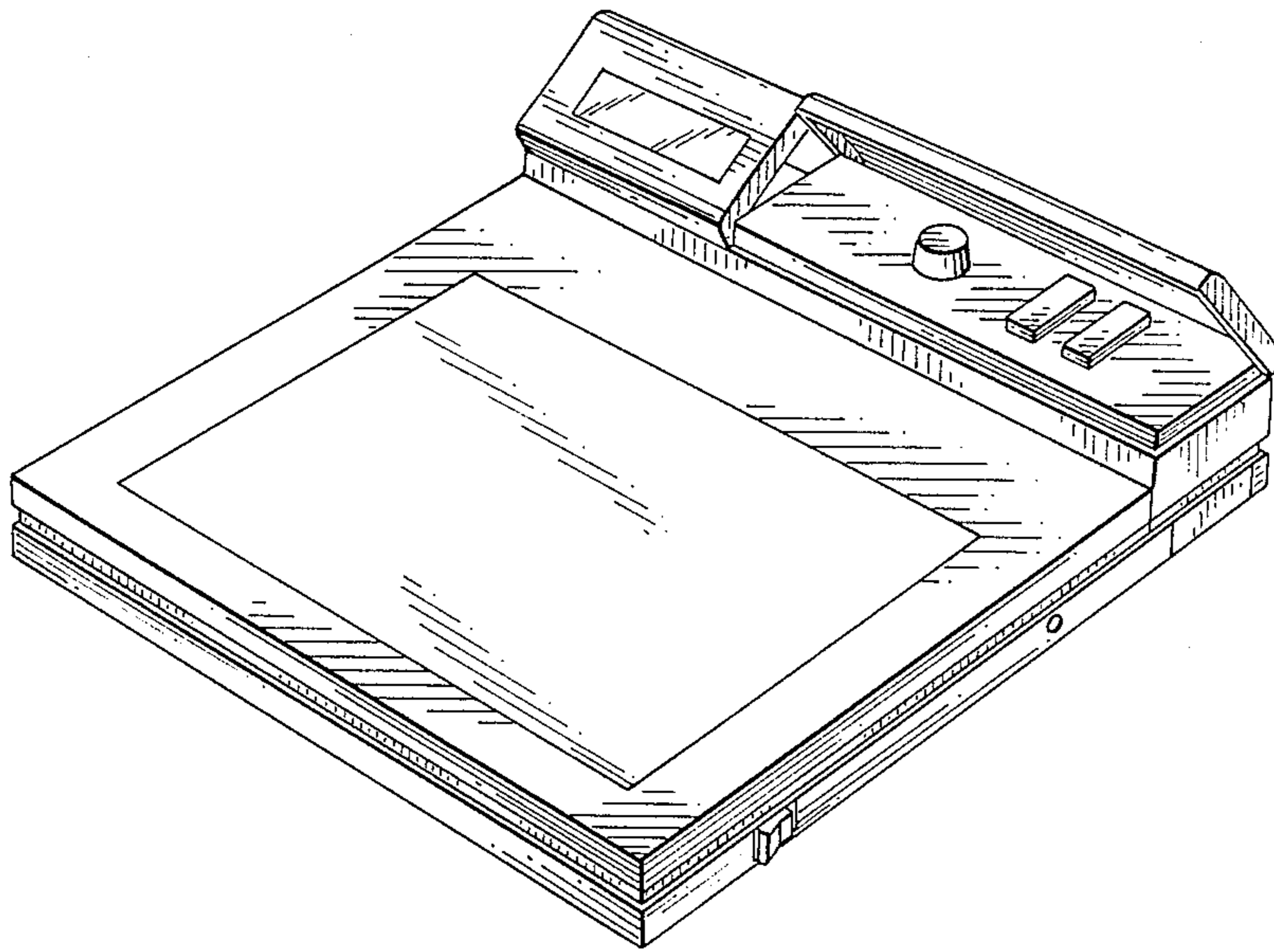

FIG. 11

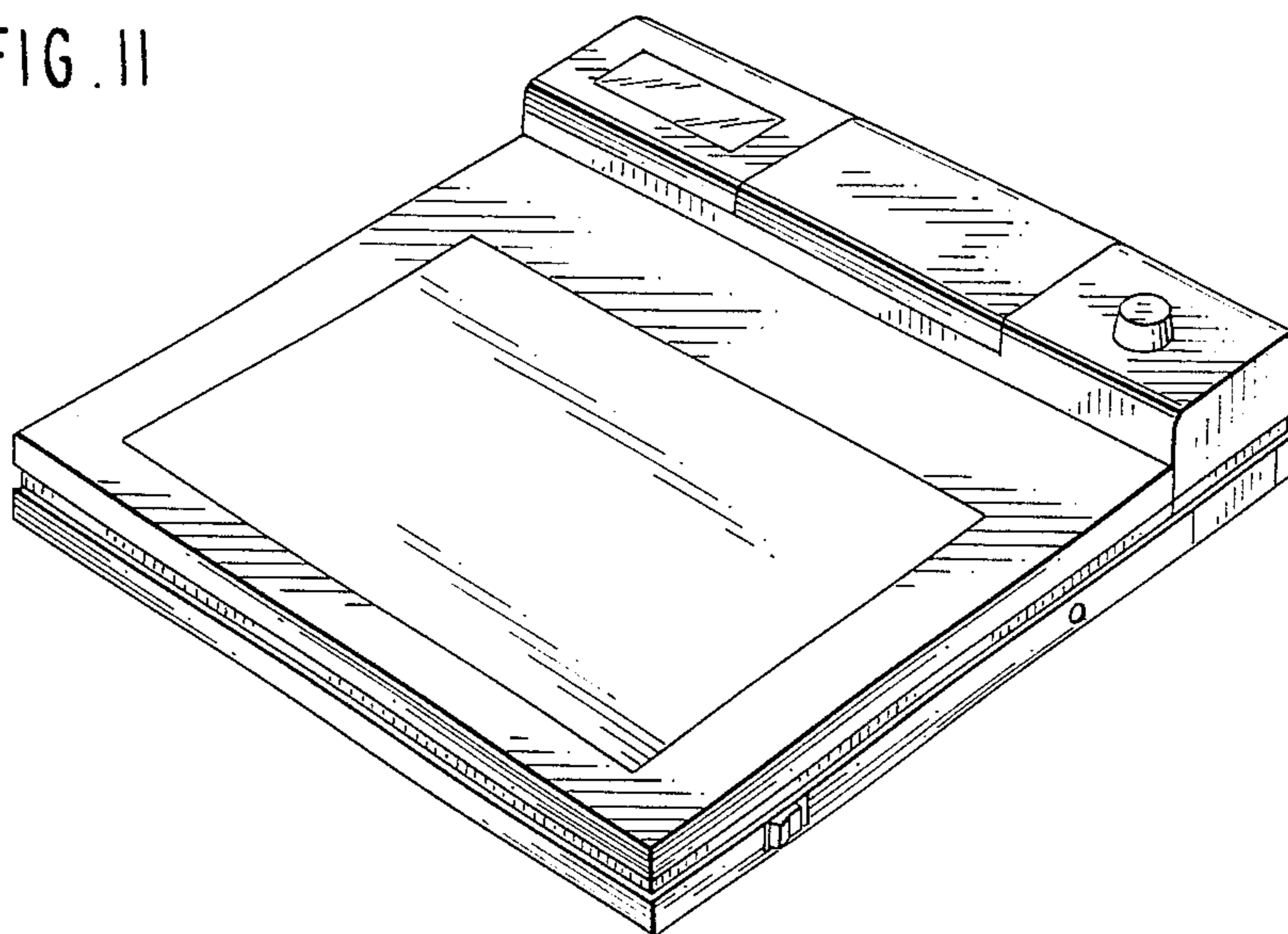

FIG. 12

