

[54] TOY AIRCRAFT

[75] Inventor: Erik P. Tapdrup, Virum, Denmark

[73] Assignee: Interlego A.G., Baar, Switzerland

[**] Term: 14 Years

[21] Appl. No.: 128,474

[22] Filed: Dec. 2, 1987

[52] U.S. Cl. D21/90; D21/148

[58] Field of Search D21/82, 84, 85, 86, D21/87, 90, 91, 108, 150; D12/319, 320, 323, 325; 446/36, 85, 88, 93, 94, 108, 116, 118, 120, 220, 225, 230, 231, 232

[56] References Cited

U.S. PATENT DOCUMENTS

- D. 225,248 11/1972 Ostrander D21/87
- D. 254,918 5/1980 Havranek D21/87
- D. 280,222 8/1985 Tapdrup et al. D21/108
- D. 280,838 10/1985 Tapdrup et al. D21/108
- D. 290,031 5/1987 Dideriksen D21/87

FOREIGN PATENT DOCUMENTS

- 1092356 11/1957 Fed. Rep. of Germany 446/232

OTHER PUBLICATIONS

Sears Specialog 1982, p. 612, #3, Jetliner.
Hong Kong Toys '85, p. 12, #84/4.

Primary Examiner—Charles A. Rademaker
Assistant Examiner—Alicia A. Farrell
Attorney, Agent, or Firm—Kane, Dalsimer, Sullivan, Kurucz, Levy, Eisele and Richard

[57] CLAIM

The ornamental design for a toy aircraft, as shown and described.

DESCRIPTION

FIG. 1 is a top perspective view of a toy aircraft showing my new design;
FIG. 2 is a bottom perspective view thereof;
FIG. 3 is a top plan view thereof;
FIG. 4 is a left side elevational view thereof;
FIG. 5 is a right side elevational view thereof;
FIG. 6 is a front elevational view thereof;
FIG. 7 is a rear elevational view thereof;
FIG. 8 is a bottom plan view thereof; and,
FIG. 9 is a top perspective view thereof, in an opened position.

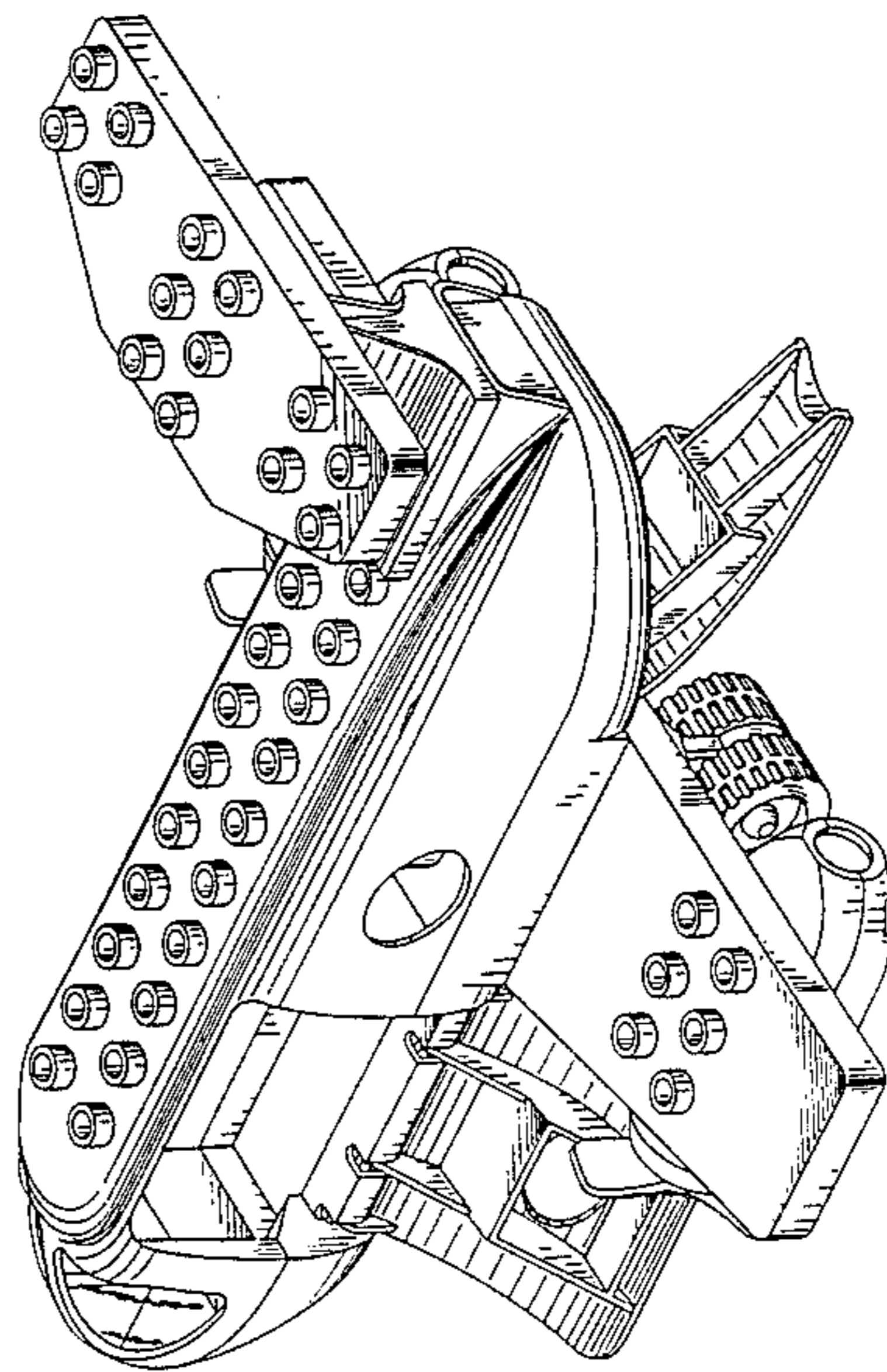
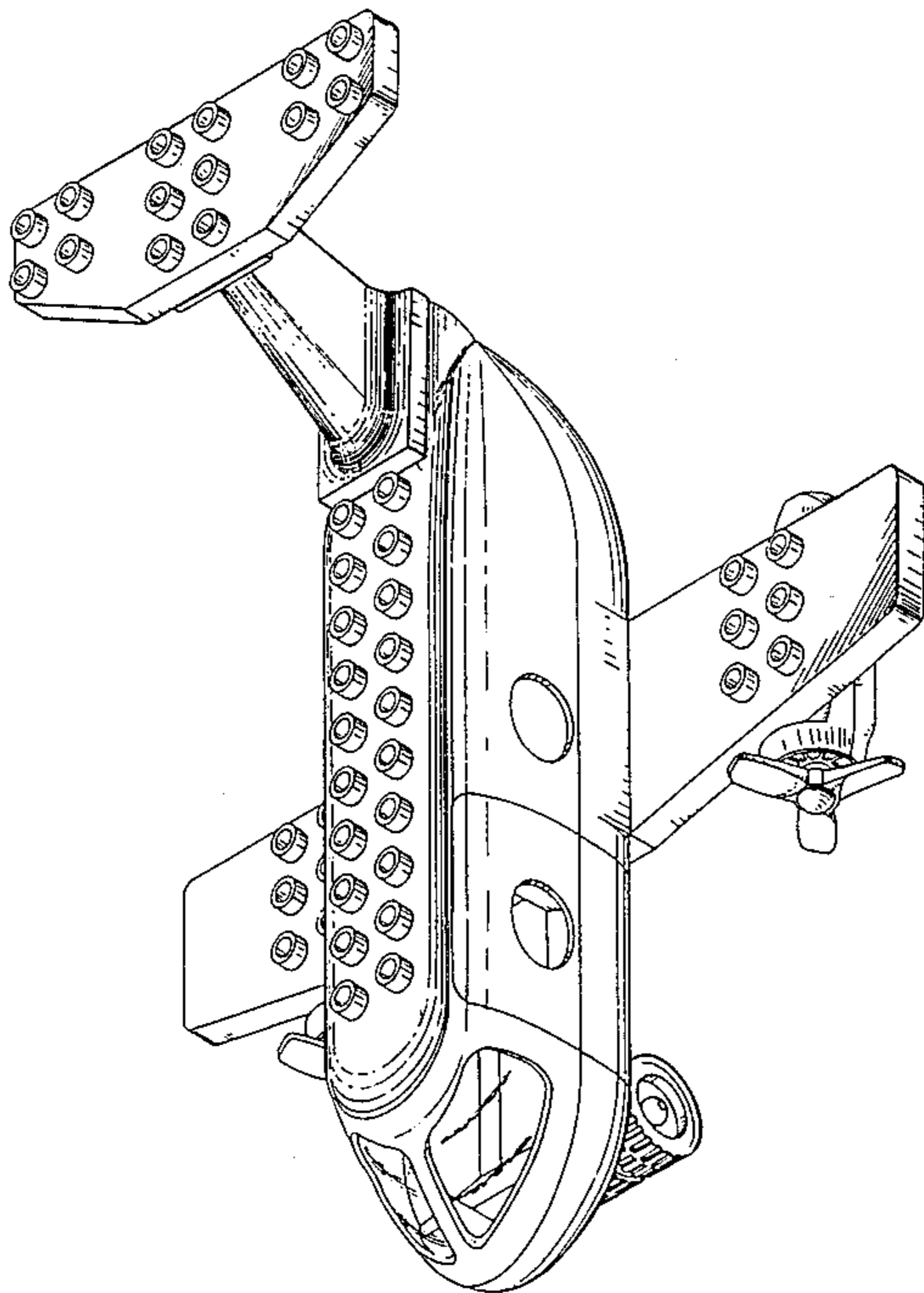

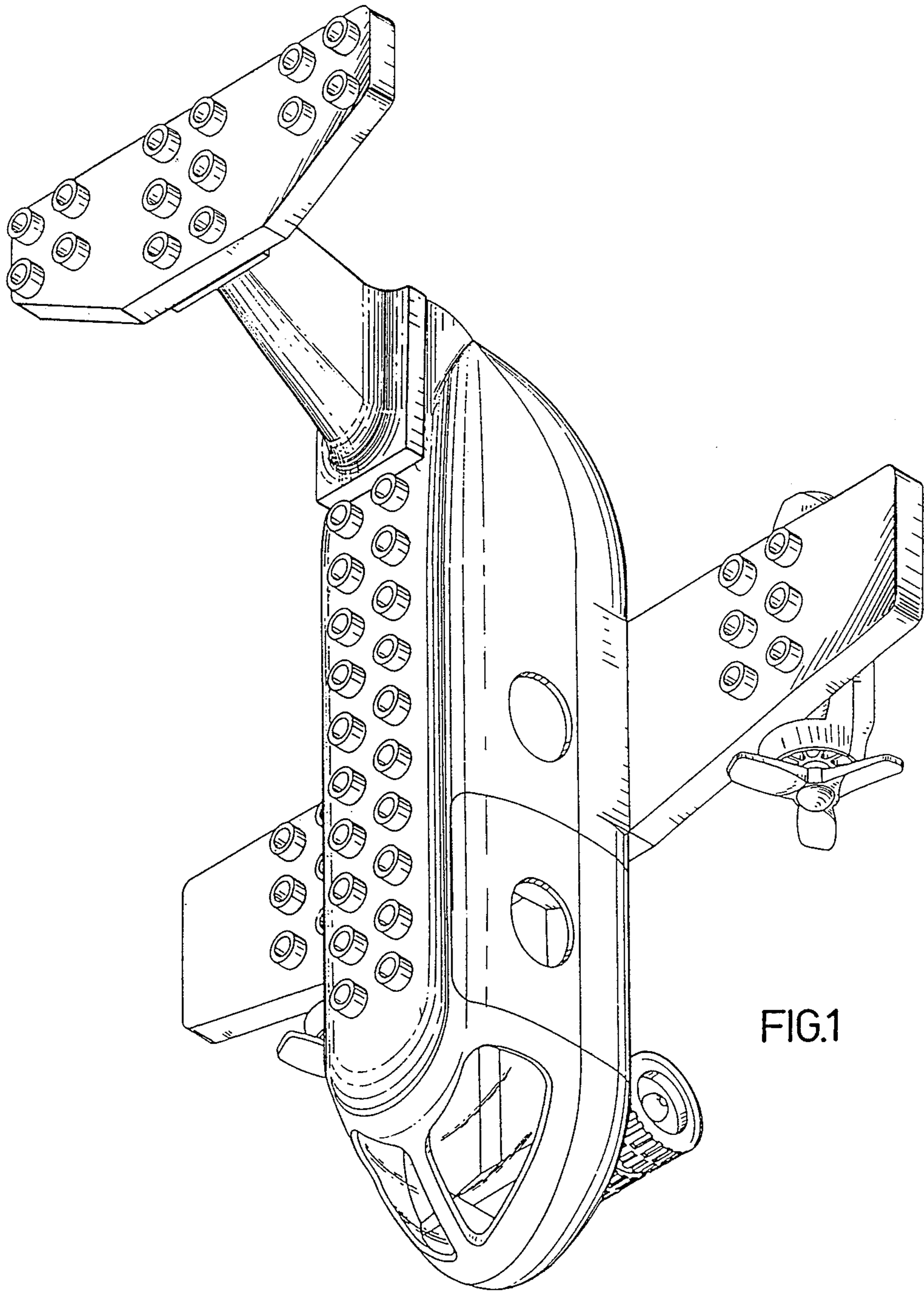

FIG.1

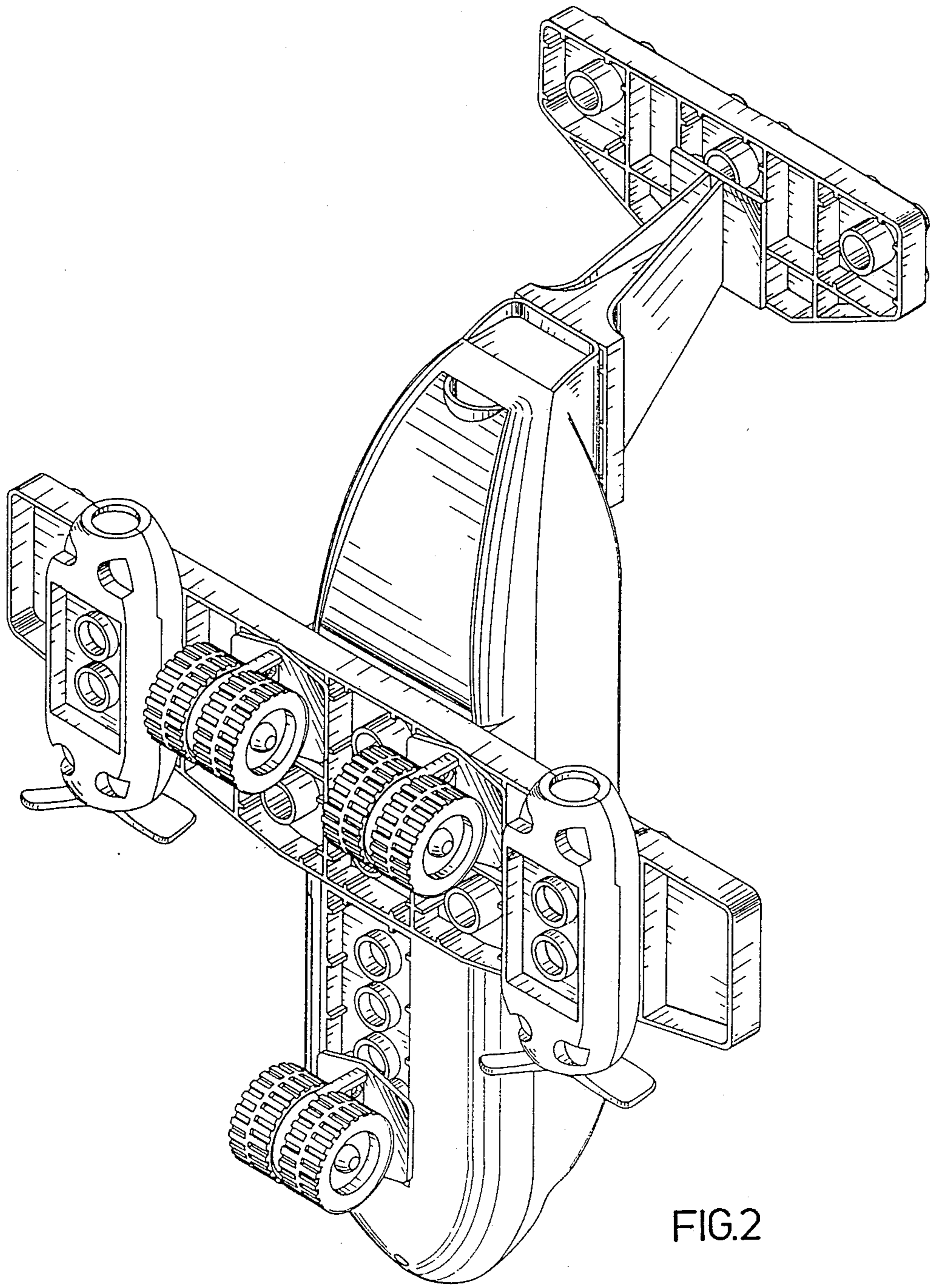

FIG.2

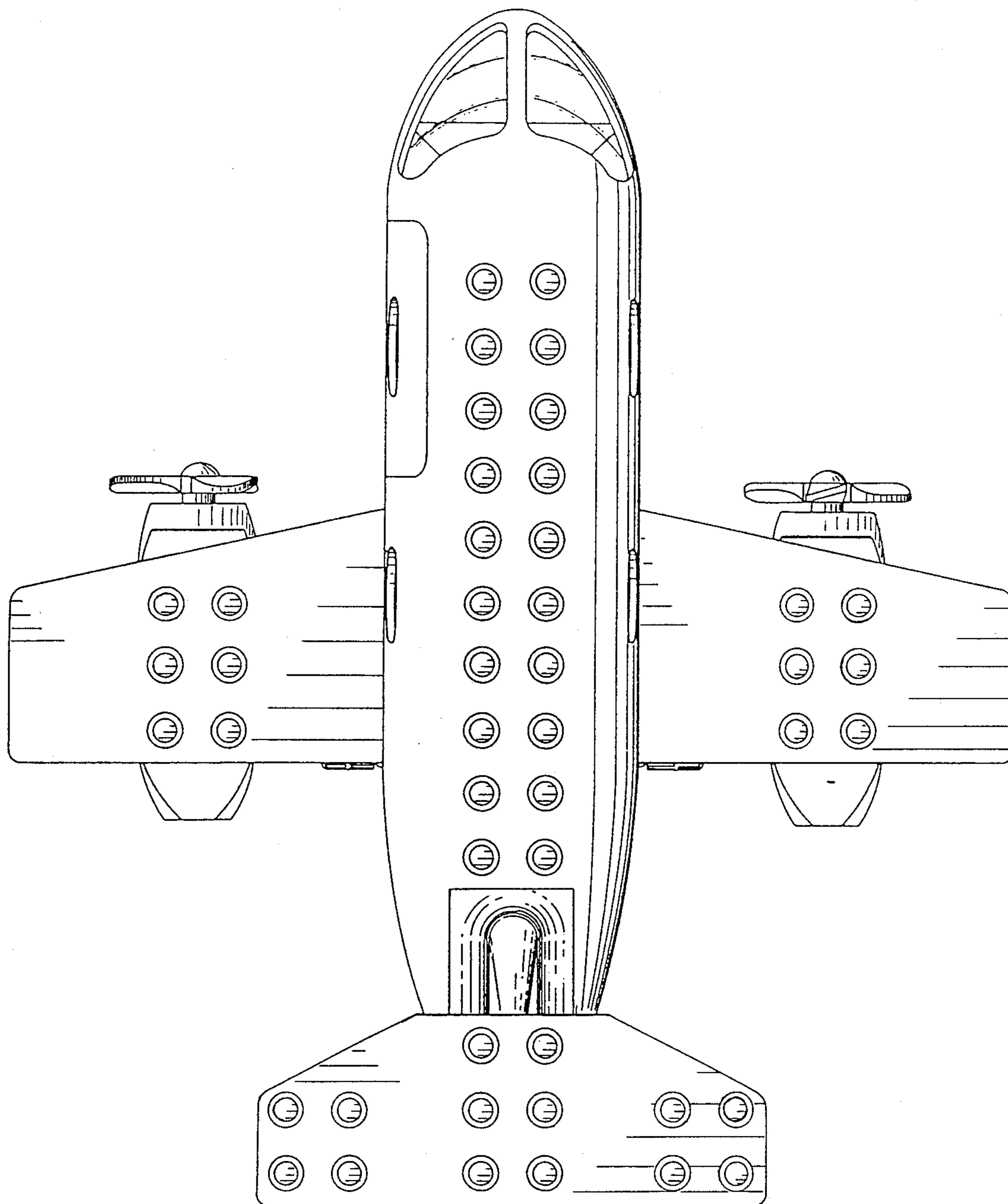

FIG.3

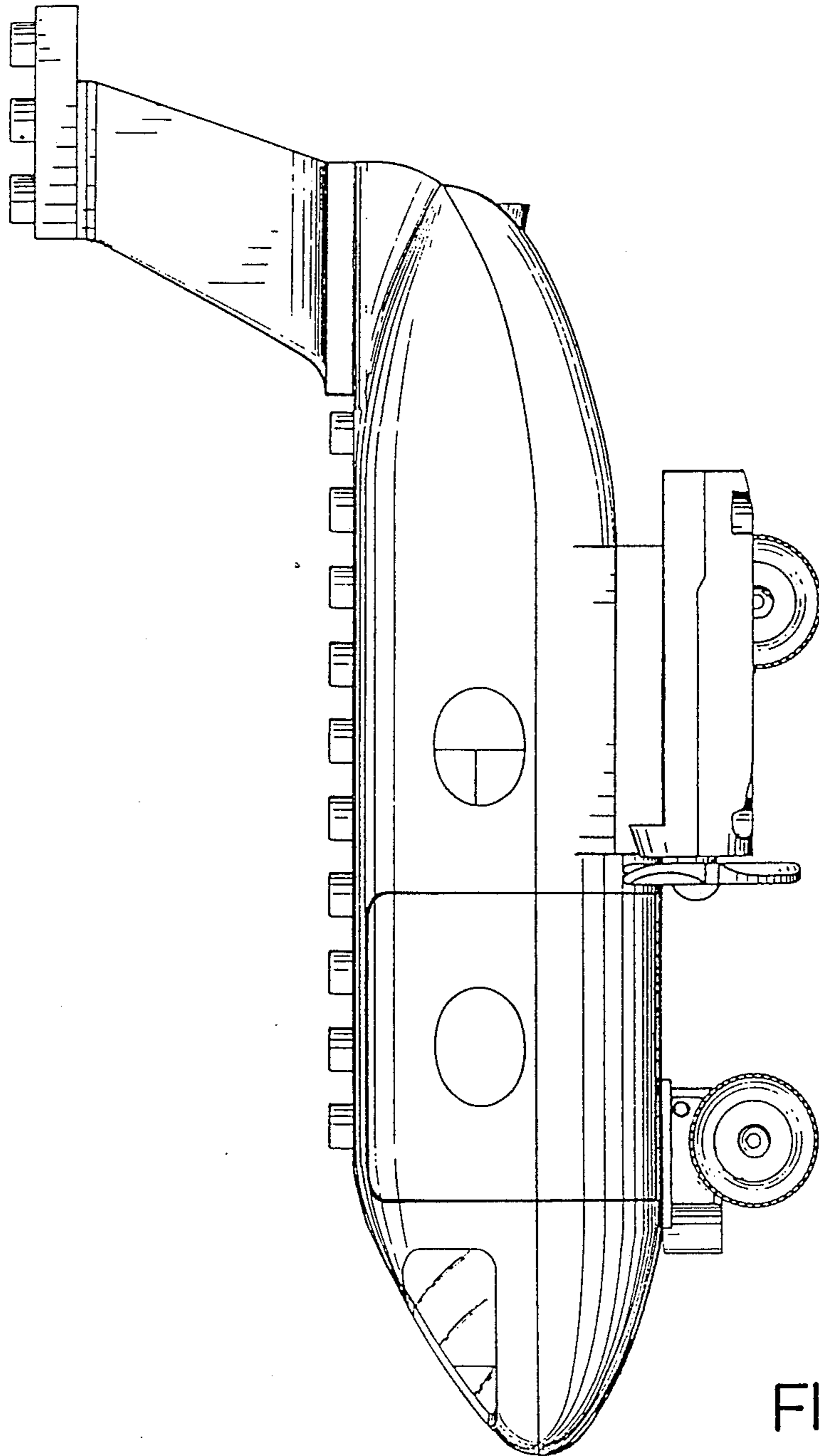
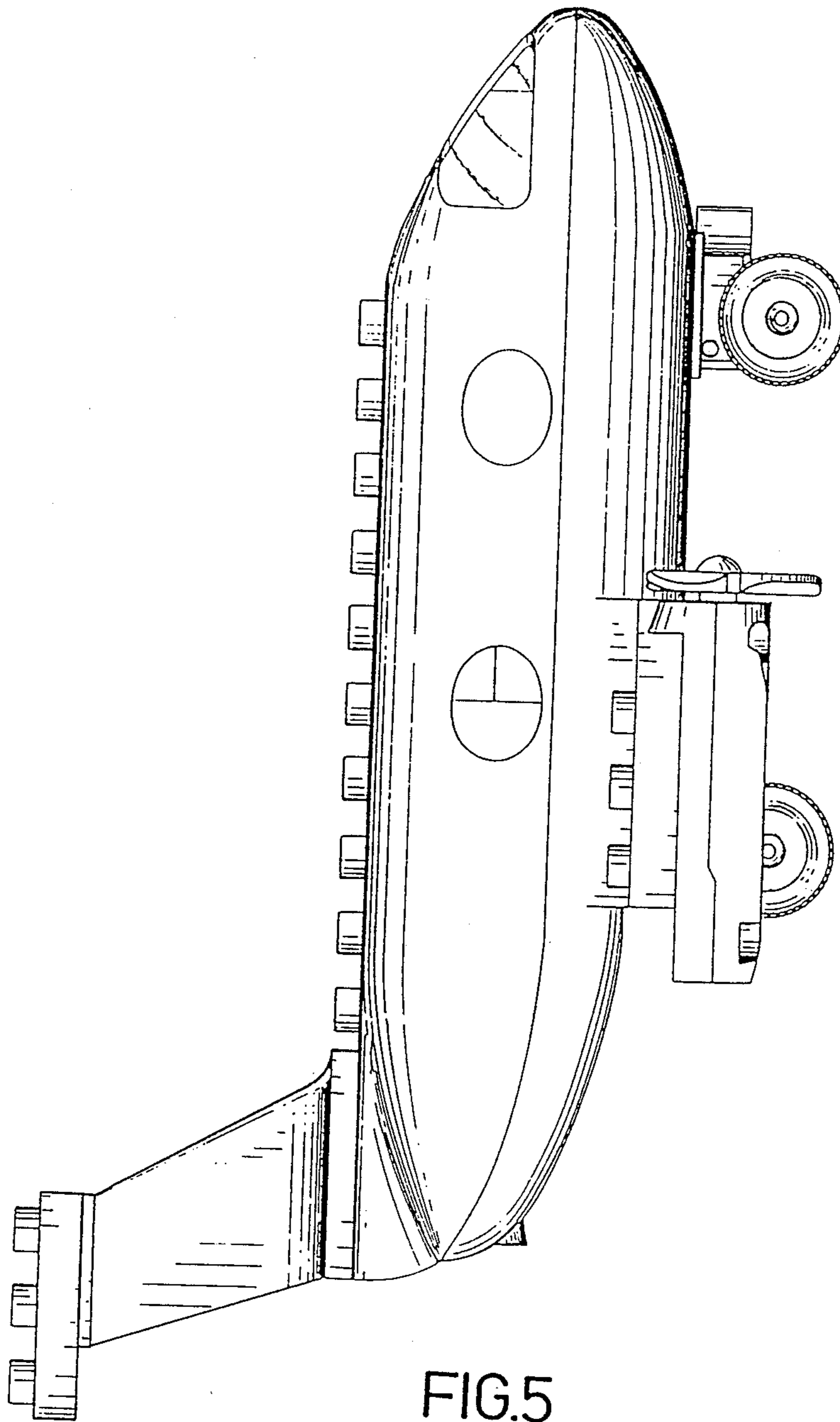

FIG.4



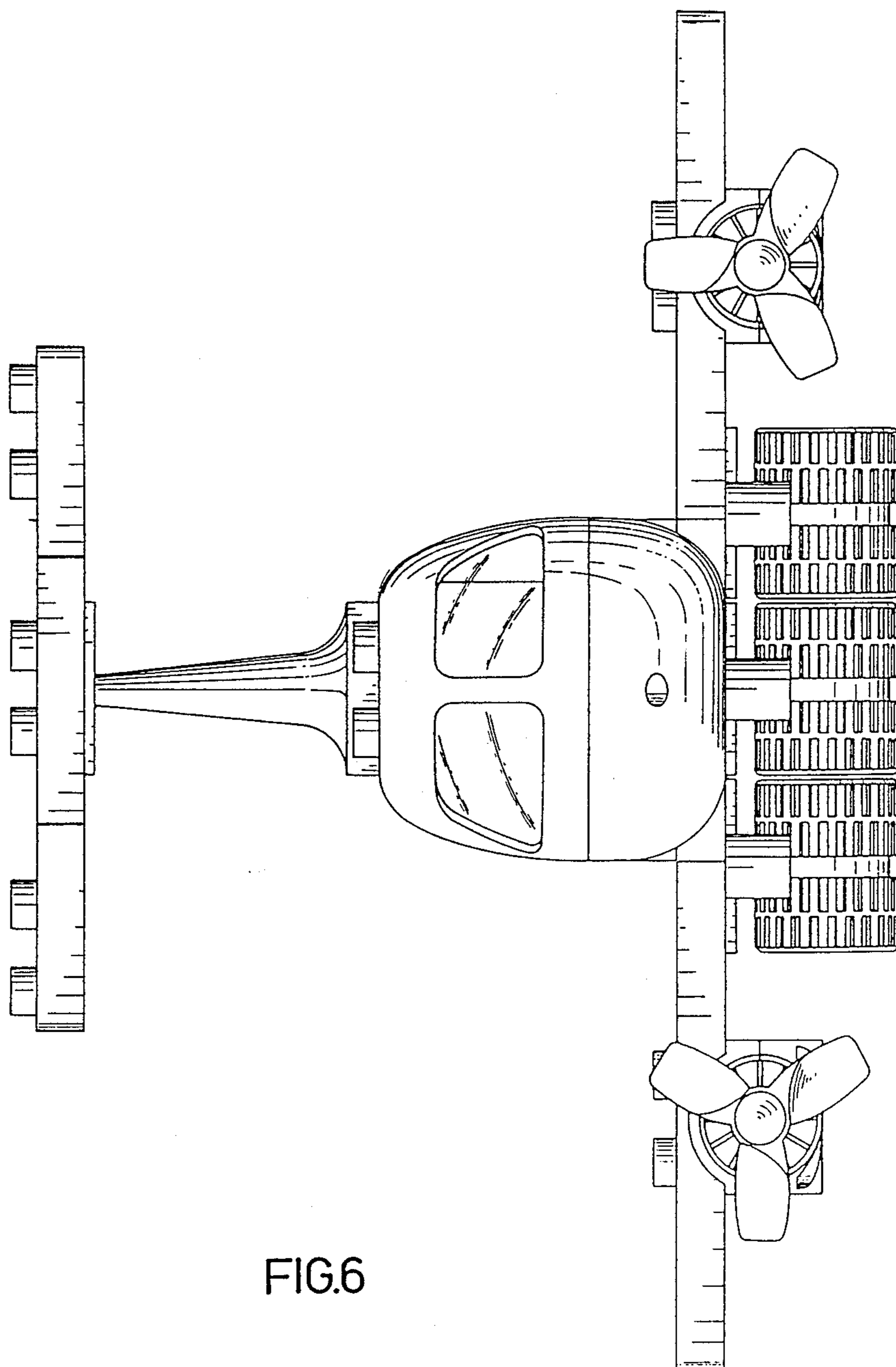

FIG.6

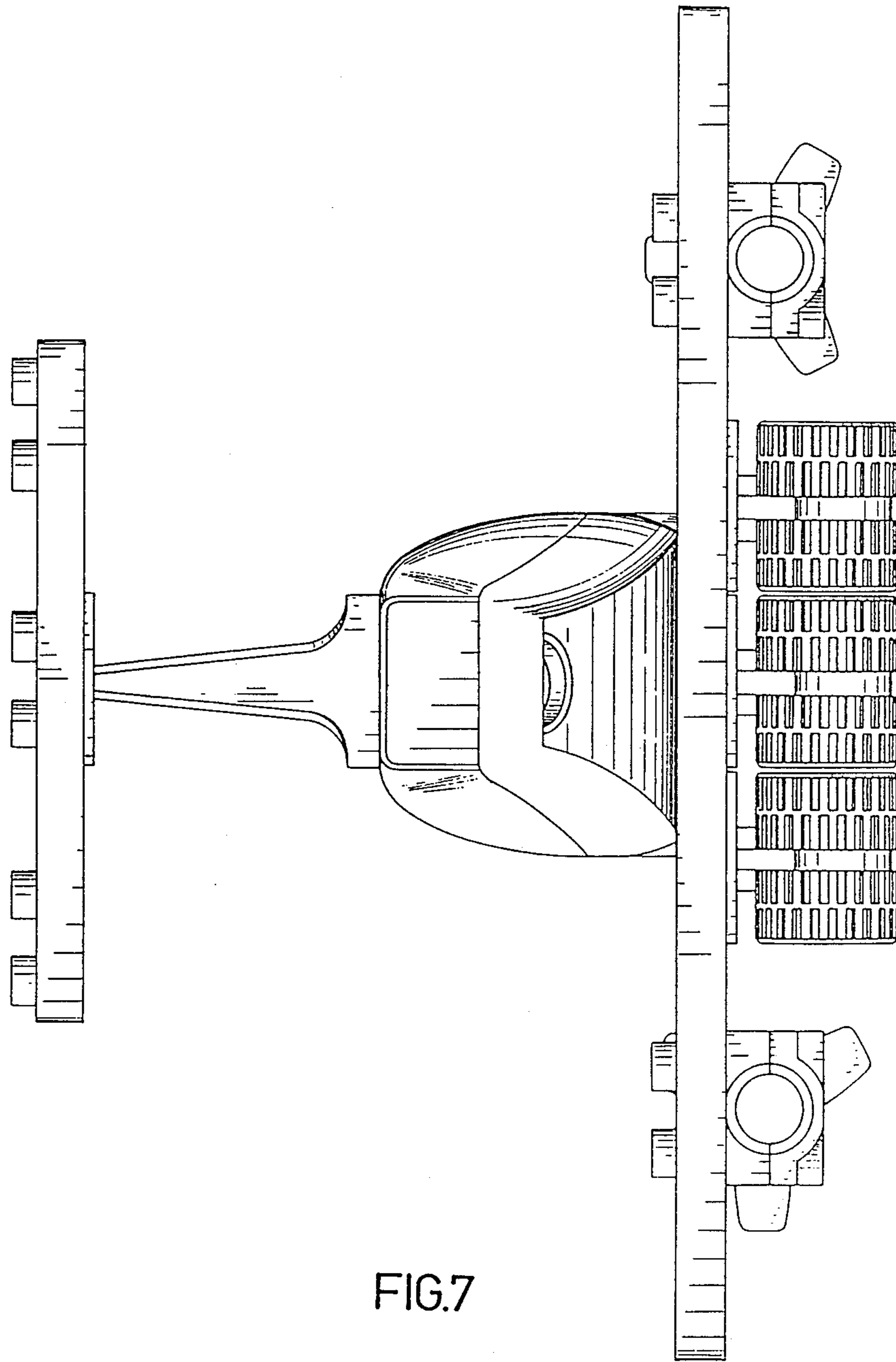

FIG.7

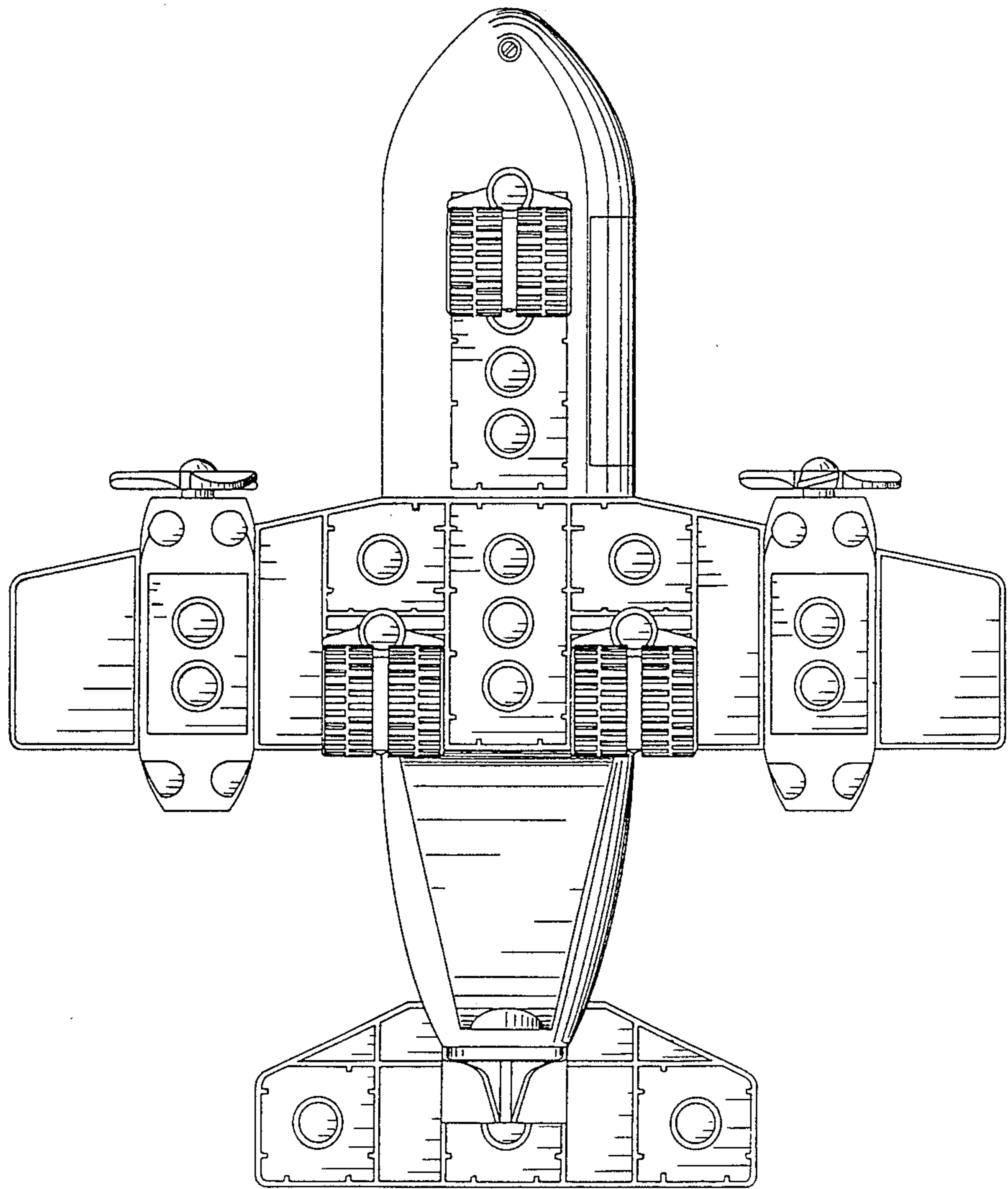

FIG. 8

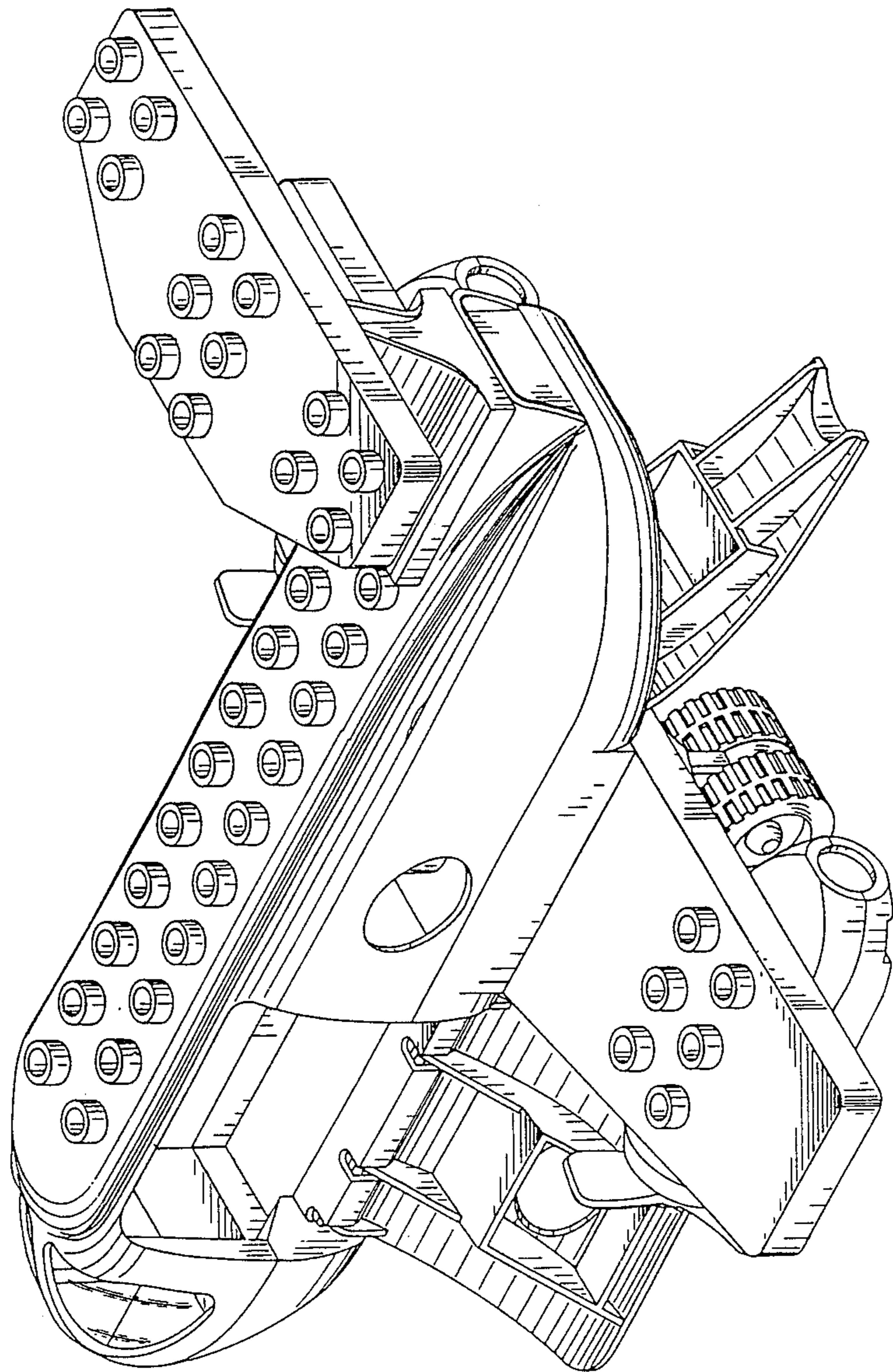

FIG.9