

[54] COMBINED PORTABLE INTERNAL COMBUSTION ENGINE AND TOOL

D. 290,365 6/1987 Hatano et al. D15/10
D. 292,890 12/1987 Tomita et al. D15/16

[75] Inventors: Katsumi Kiyooka, Warabi; Tetsuo Ueno, Higashiyamato; Hideko Inomata, Higashi-Yamato; Kiyoshi Anbo, Fussaku, all of Japan

Primary Examiner—Bruce W. Dunkins
Assistant Examiner—Ruth Takemoto
Attorney, Agent, or Firm—Foley & Lardner, Schwartz, Jeffery, Schwaab, Mack, Blumenthal & Evans

[73] Assignee: Komatsu Zenoah Company, Tokyo, Japan

[57] CLAIM

[**] Term: 14 Years

The ornamental design for a combined portable internal combustion engine and tool, as shown and described.

[21] Appl. No.: 865,286

DESCRIPTION

[22] Filed: May 21, 1986

[52] U.S. Cl. D15/10

[58] Field of Search D15/1, 10-12, D15/16, 28-29; D8/7, 70; D32/15-16, 25, 19; 417/234; 239/346; 15/328

FIG. 1 is a left side elevational view of a combined portable internal combustion engine and tool showing our new design;

FIG. 2 is a right side elevational view thereof;

FIG. 3 is a top plan view thereof;

FIG. 4 is a bottom plan view thereof;

FIG. 5 is a front elevational view thereof;

FIG. 6 is a rear elevational view thereof;

FIG. 7 is an enlarged left side elevational view of the engine;

FIG. 8 is an enlarged right side elevational view thereof;

FIG. 9 is an enlarged top plan view thereof;

FIG. 10 is an enlarged bottom plan view thereof;

FIG. 11 is an enlarged front elevational view thereof; and

FIG. 12 is an enlarged rear elevational view thereof.

FIGS. 7-12 are shown separate for clarity of illustration only.

[56] References Cited

U.S. PATENT DOCUMENTS

D. 190,665	6/1961	Heiniger	D15/11
D. 255,764	7/1980	Lombard	D15/12
D. 258,908	4/1981	Satoh	D15/11
D. 260,394	8/1981	Tuggle	D15/1
D. 266,427	10/1982	McMickle et al.	D15/12
D. 274,620	7/1984	Murakami et al.	D15/1
D. 278,537	4/1985	Krapowicz et al.	D15/12
D. 279,319	6/1985	McCloskey et al.	D32/15
D. 285,848	9/1986	Iida et al.	D32/15
D. 286,927	11/1986	Aiyama	D32/15
D. 287,367	12/1986	Woods	D15/12

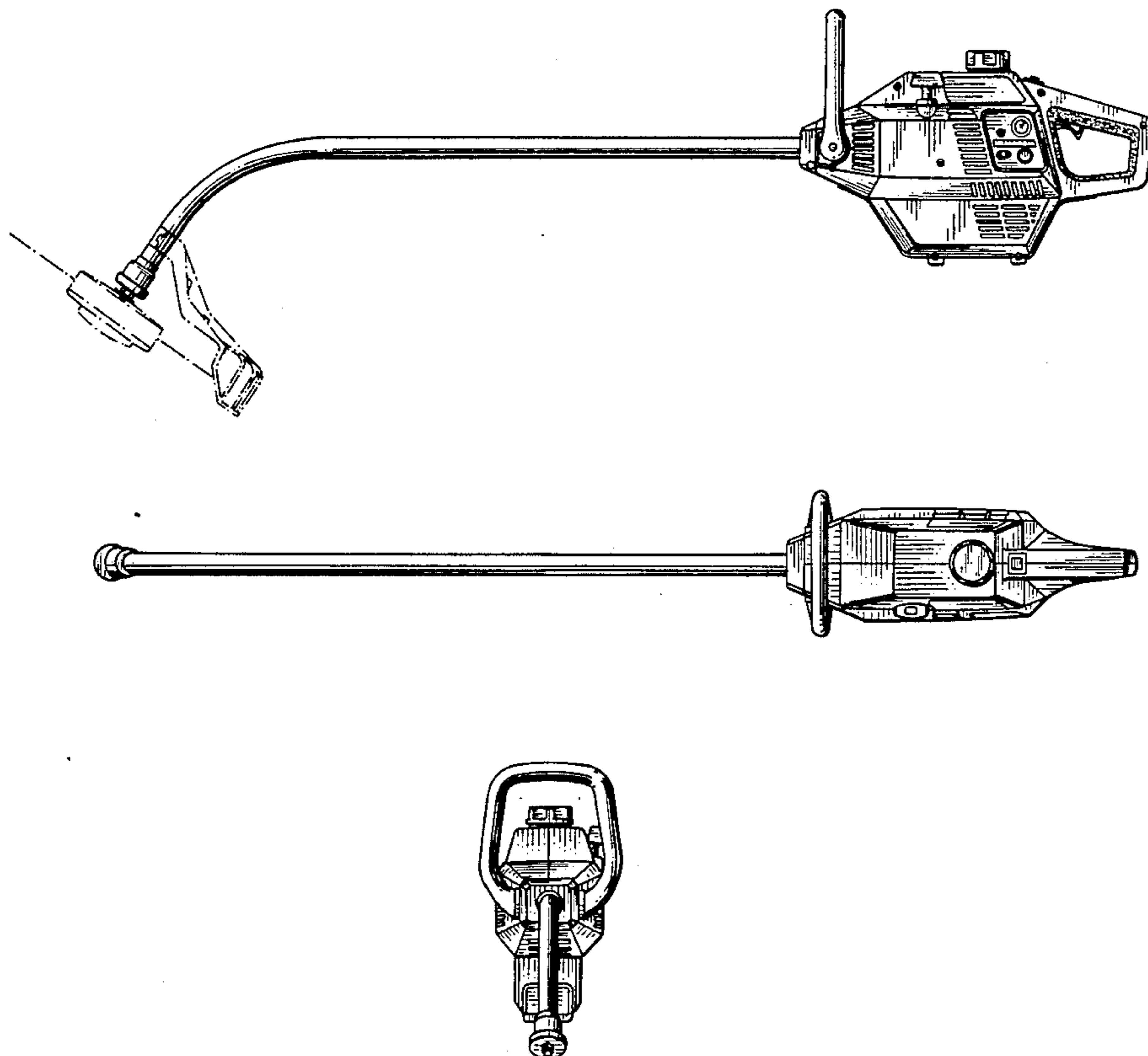

FIG. 1

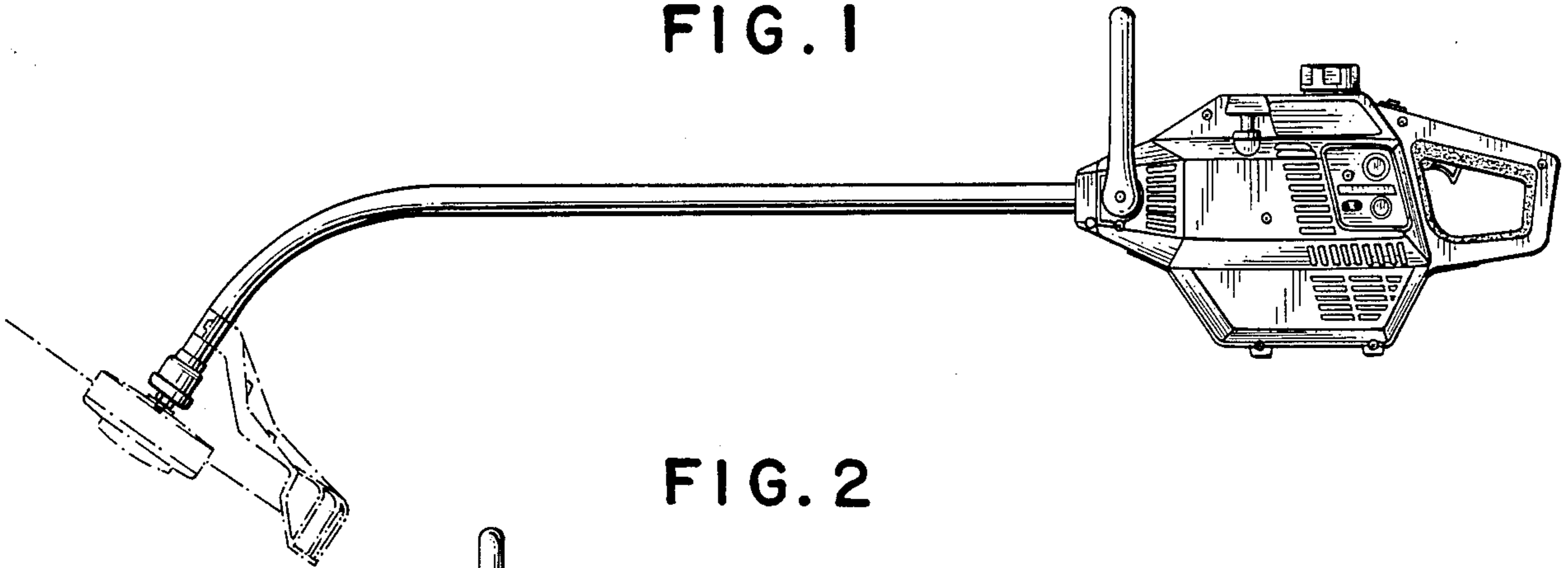

FIG. 2

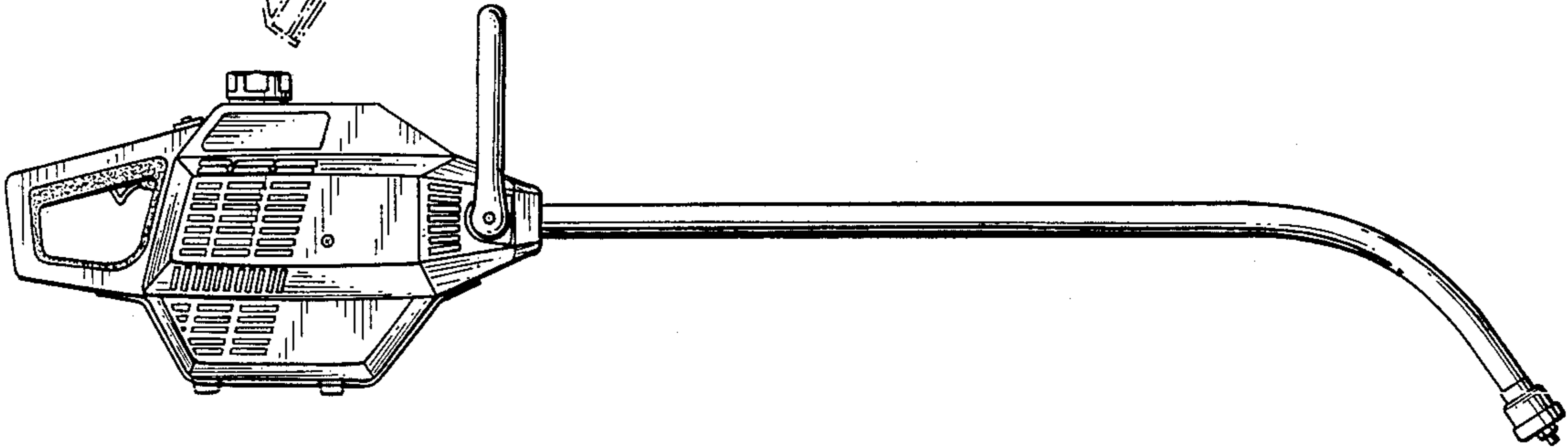

FIG. 3

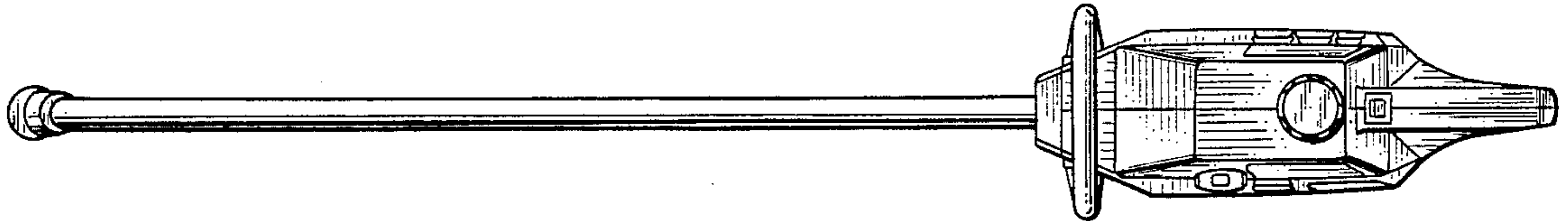

FIG. 4

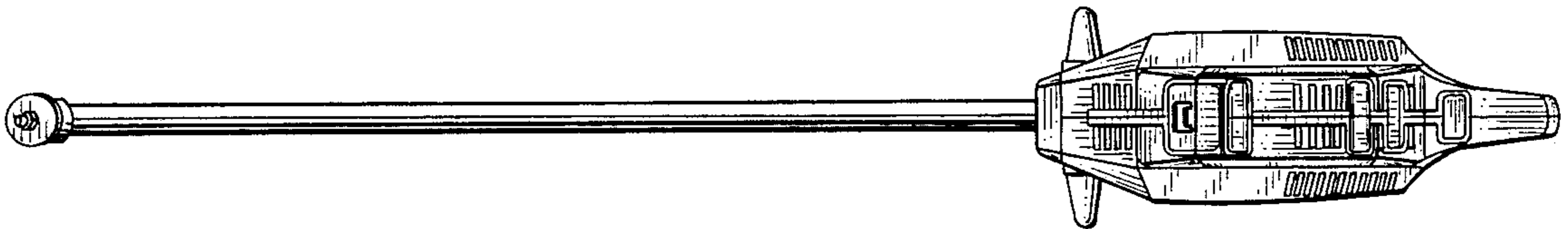

FIG. 5

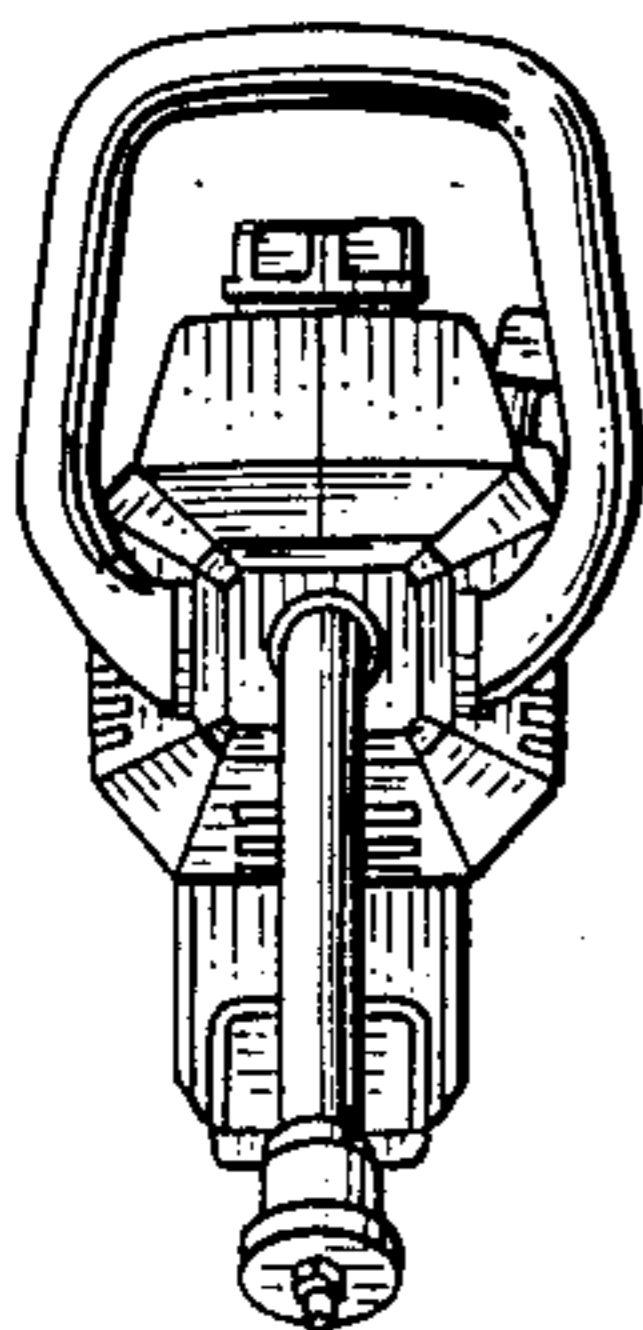

FIG. 6

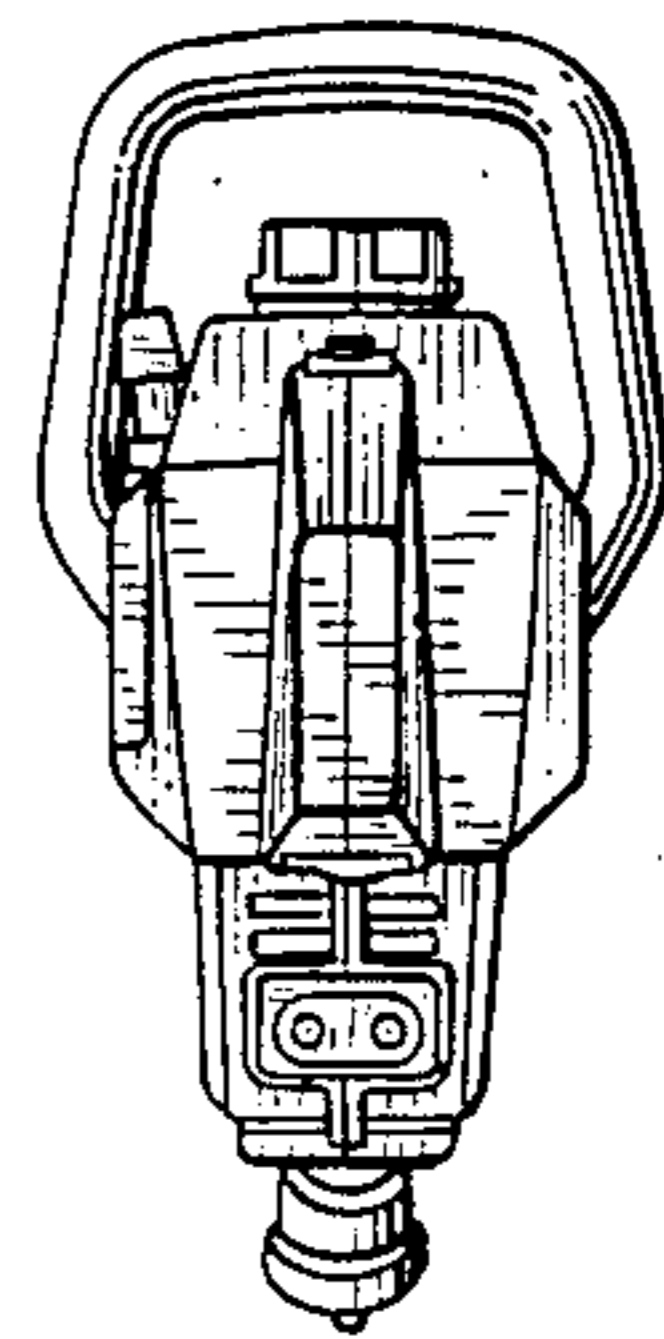

FIG. 7

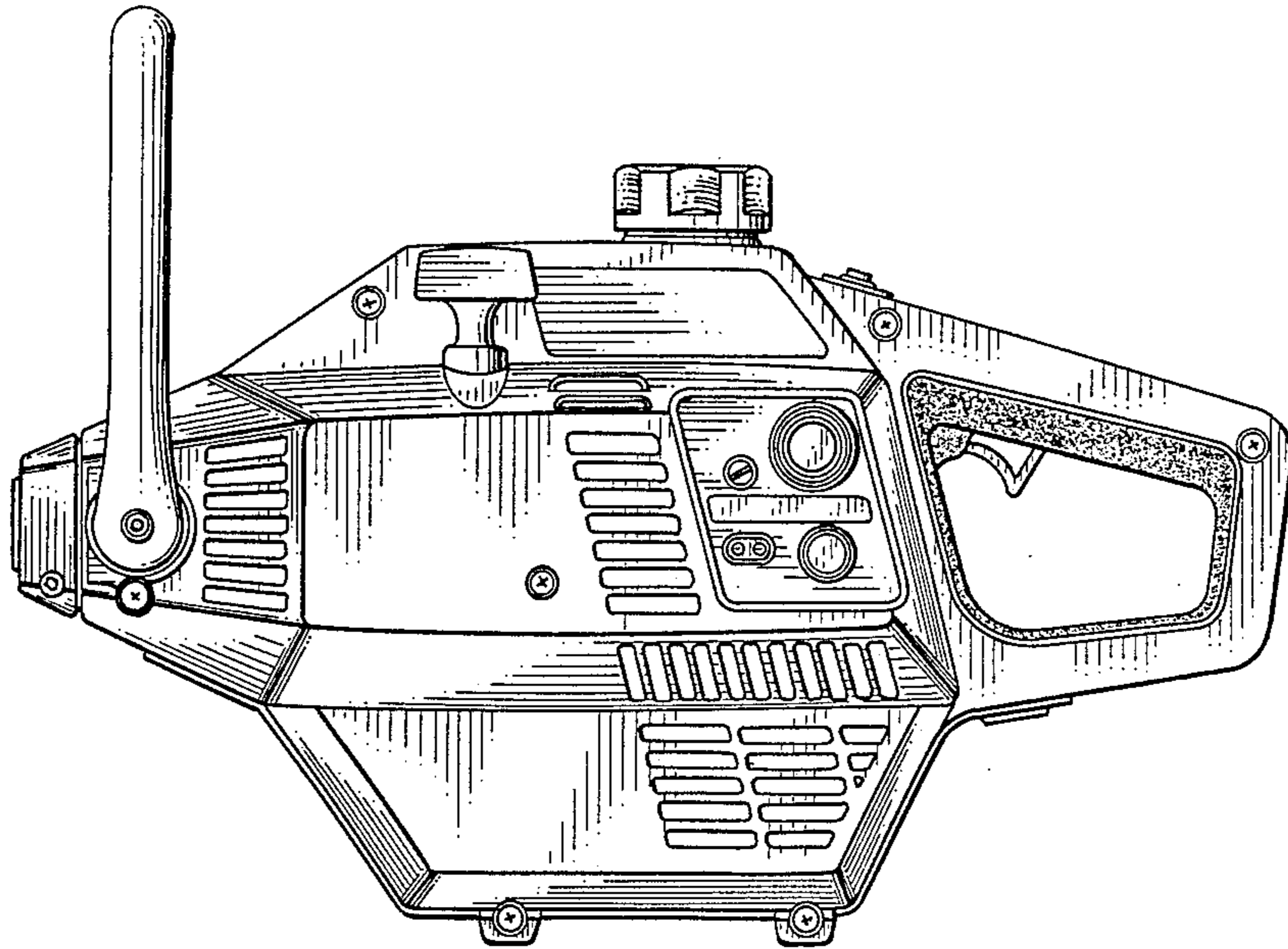

FIG. 8

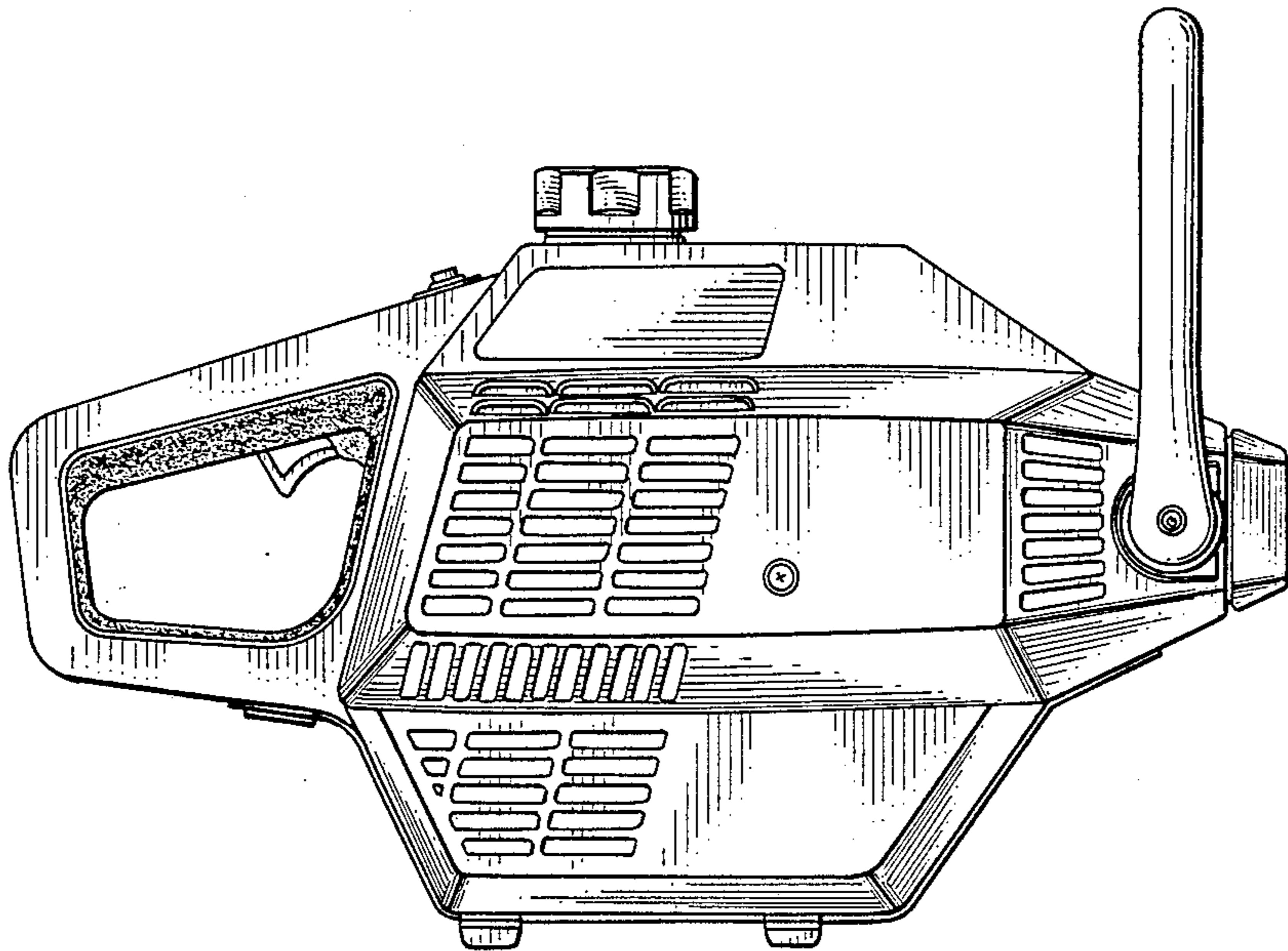

FIG. 9

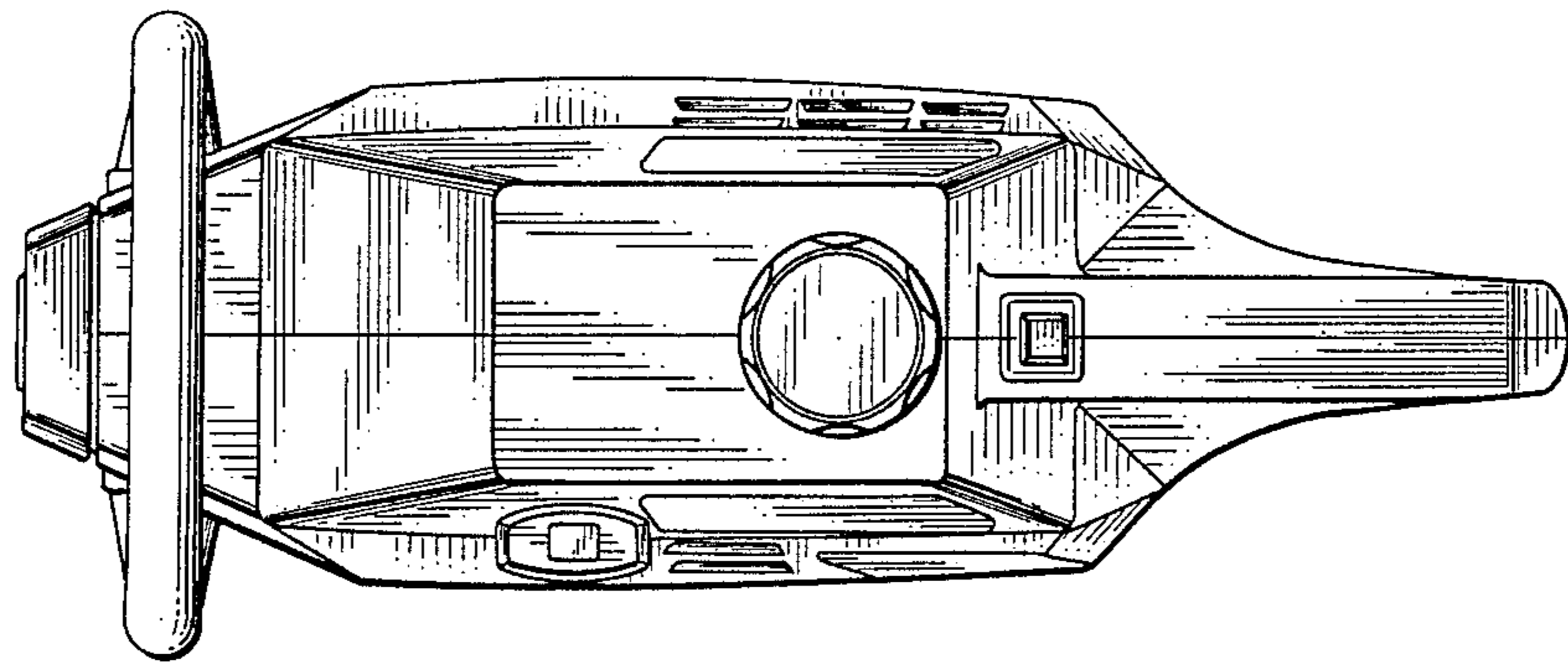

FIG. 10

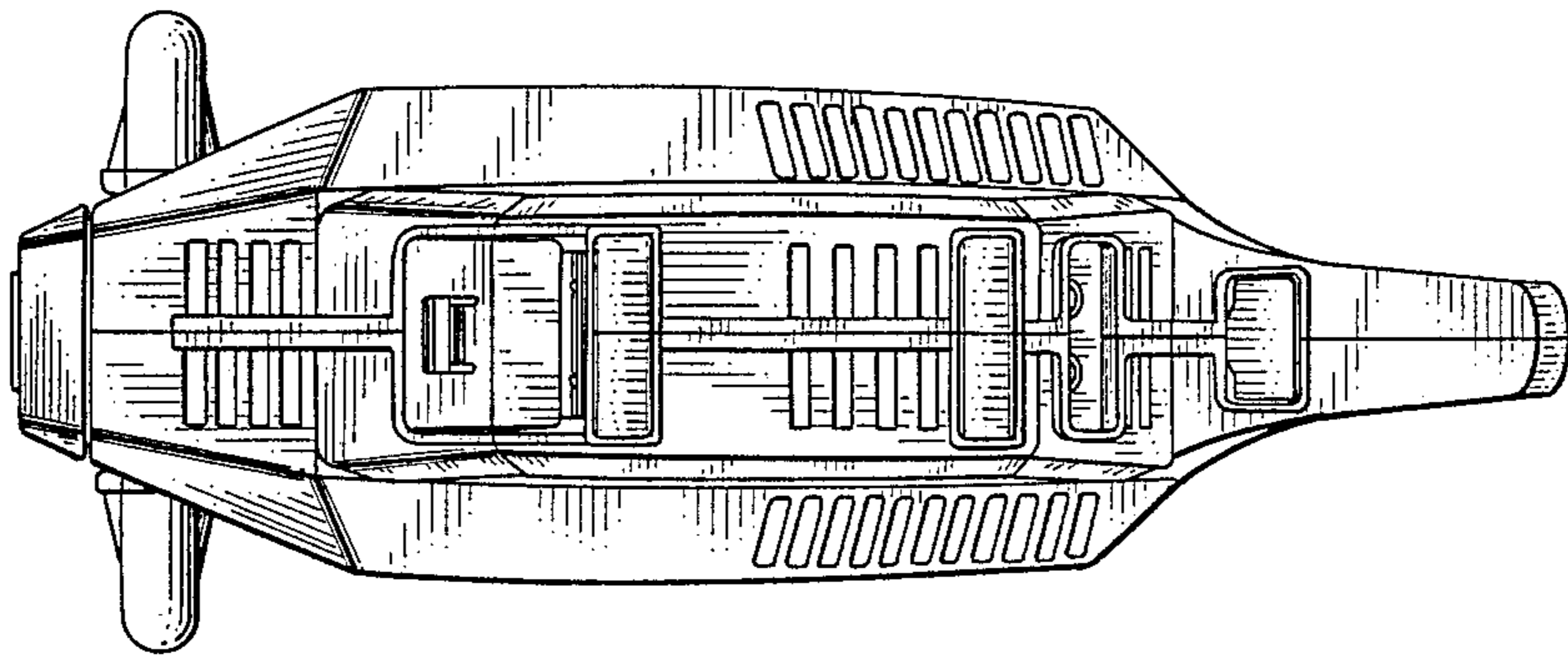

FIG. 11

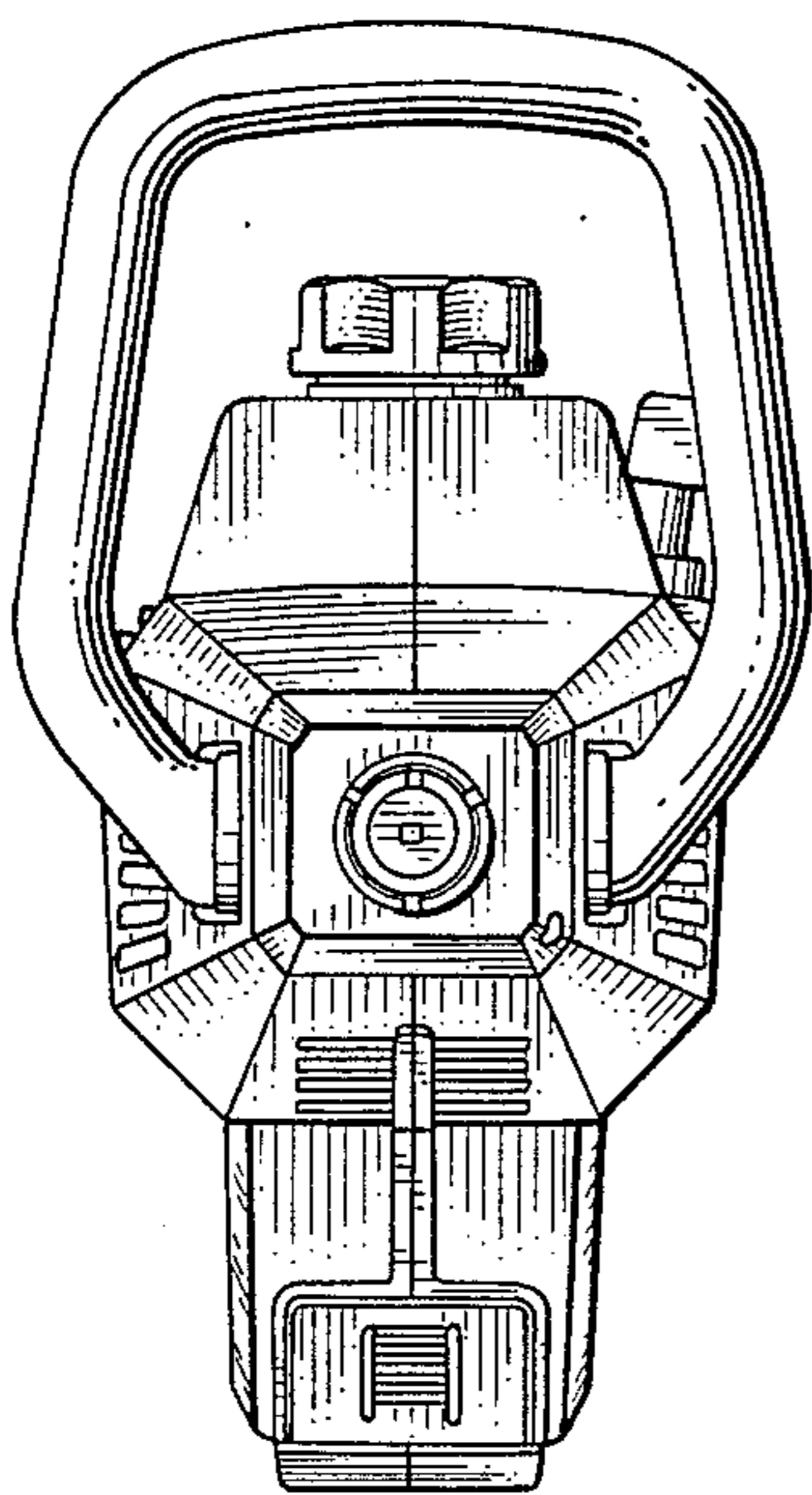

FIG. 12

