

[54] AUTOMOBILE WHEEL

[75] Inventor: Motoaki Minowa, Saitama, Japan

[73] Assignee: Honda Giken Kogyo Kabushiki Kaisha, Tokyo, Japan

[\*\*] Term: 14 Years

[21] Appl. No.: 62,823

[22] Filed: Jun. 15, 1987

[52] U.S. Cl. .... D12/211

[58] Field of Search ..... D12/209, 211, 206; 301/63 R, 64 R, 64 SD, 65

[56] References Cited

U.S. PATENT DOCUMENTS

- D. 99,055 3/1936 Sinclair ..... D12/211
- D. 292,507 10/1987 Reid ..... D12/211
- D. 294,342 2/1988 Chapman ..... D12/211

OTHER PUBLICATIONS

Tire Review, 5/86, p. 9W, 1100 FWD Wheel, lower left side of page.

Primary Examiner—James M. Gandy  
Attorney, Agent, or Firm—Lyon & Lyon

[57] CLAIM

The ornamental design for an automobile wheel, as shown.

DESCRIPTION

FIG. 1 is a front elevation view of the automobile wheel showing my new design.

FIG. 2 is a rear elevation view thereof.

FIG. 3 is a side elevation view thereof.

FIG. 4 is a sectional view thereof taken along line IV—IV in FIG. 1.

FIG. 5 is a sectional view thereof taken along line V—V in FIG. 1.

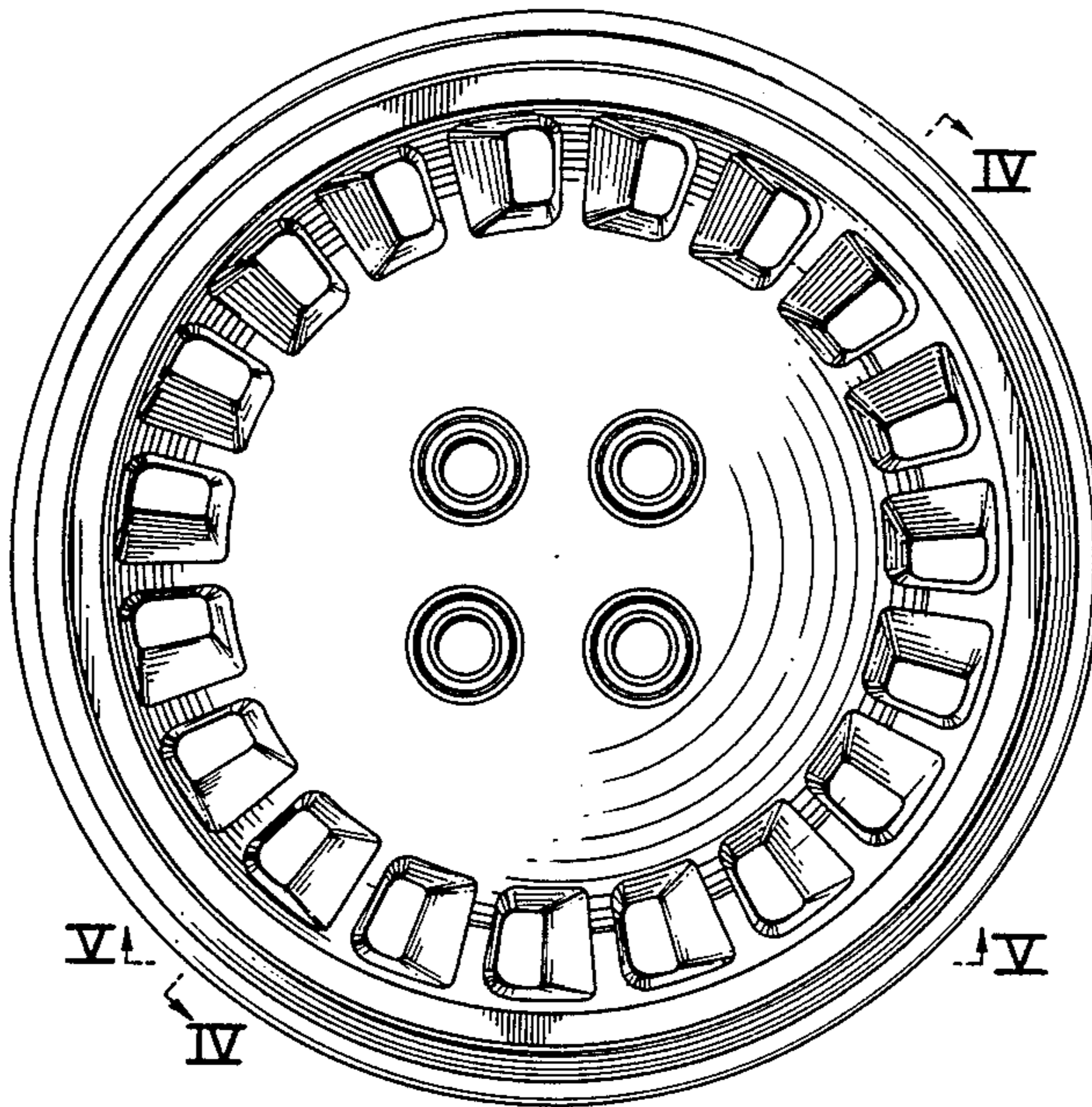

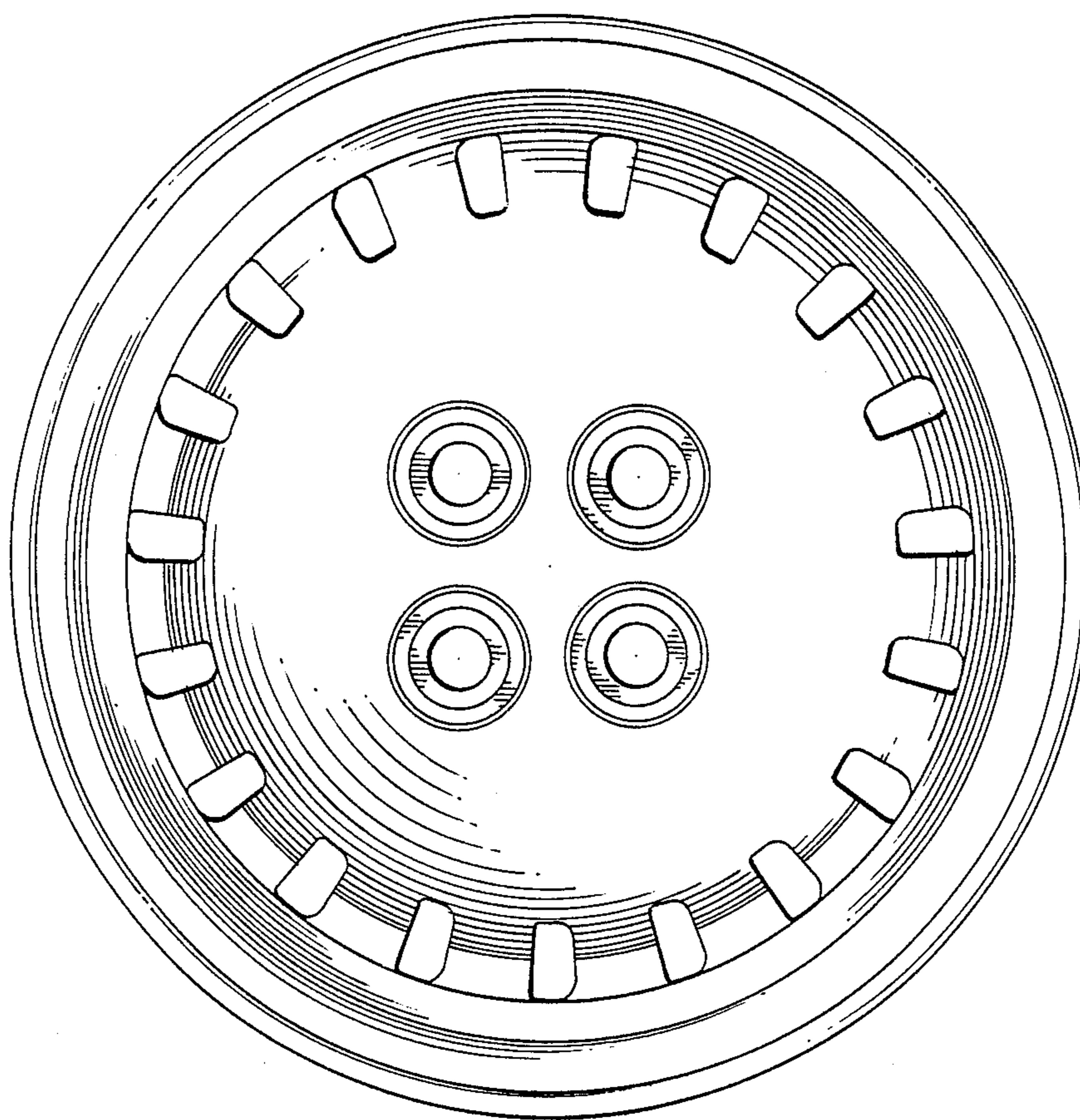

FIG. 2.

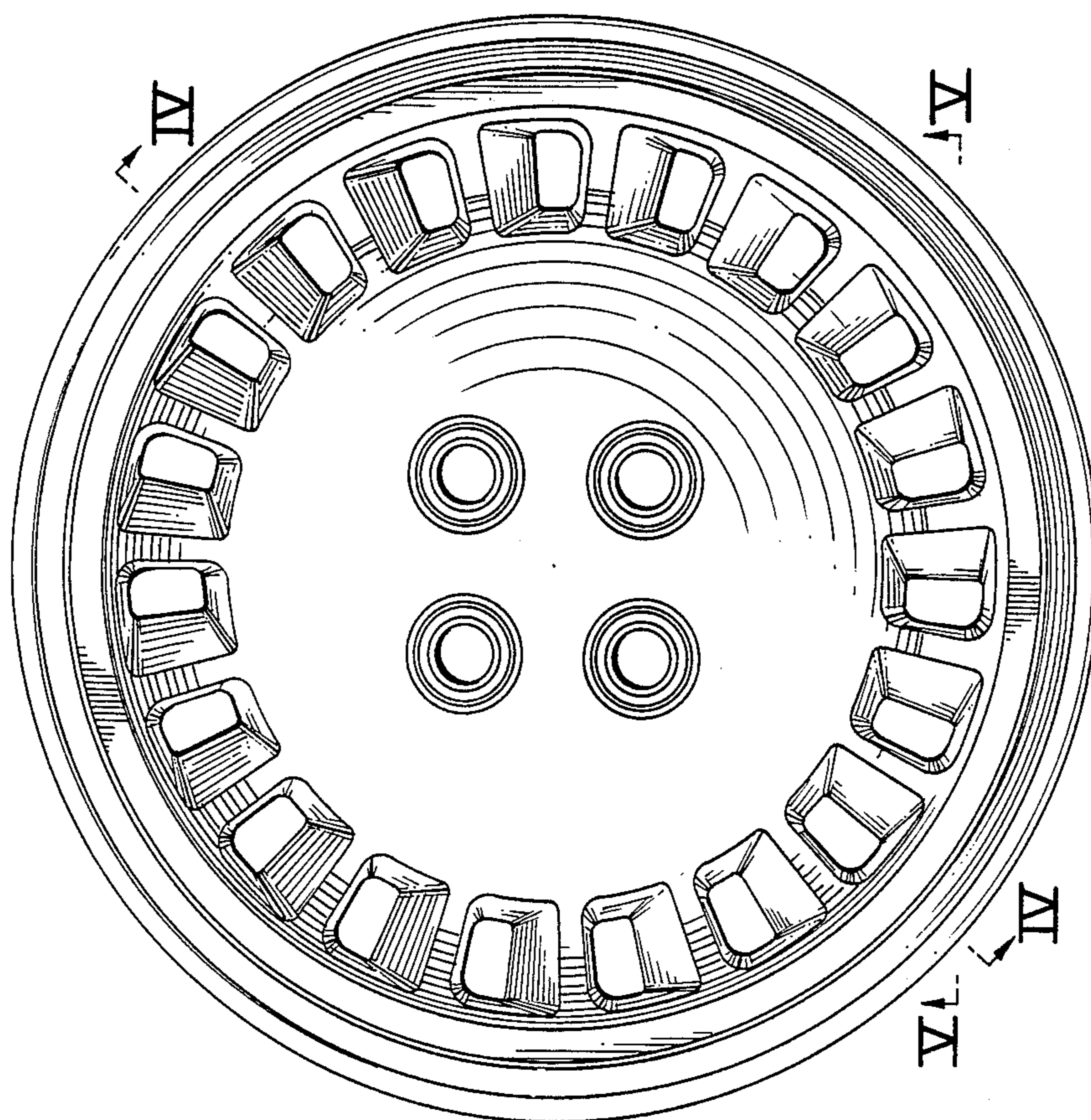

FIG. 1.

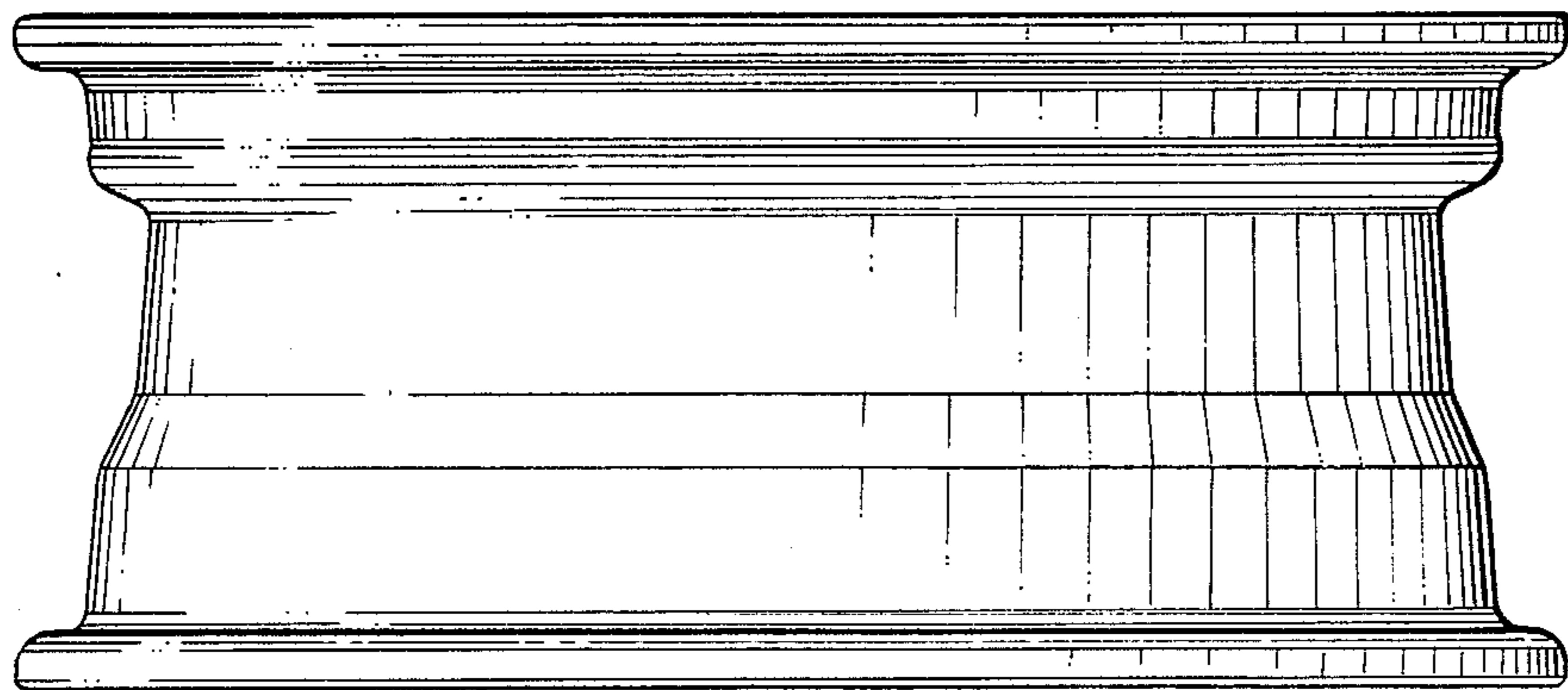

FIG. 3.

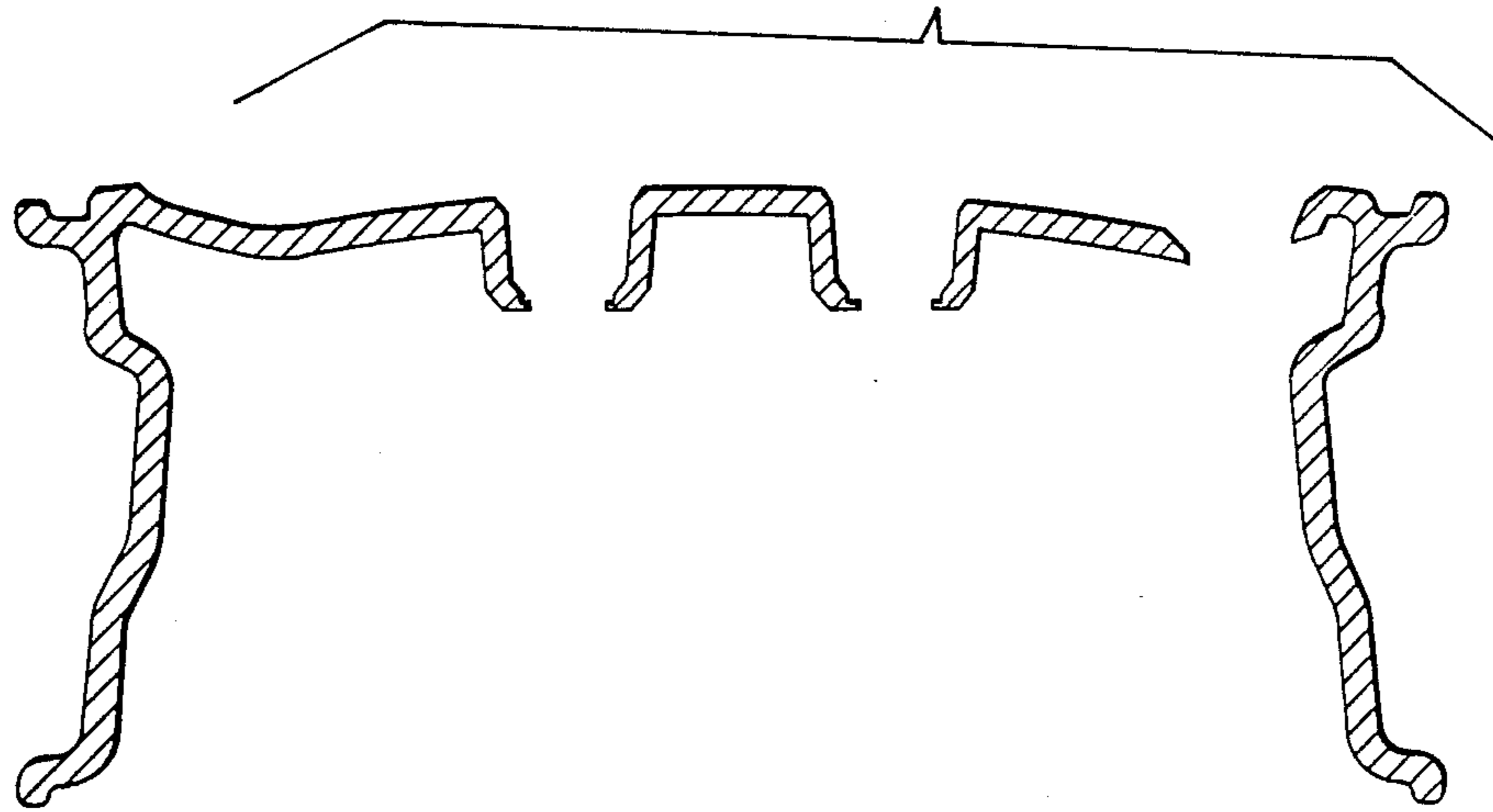

FIG. 4.

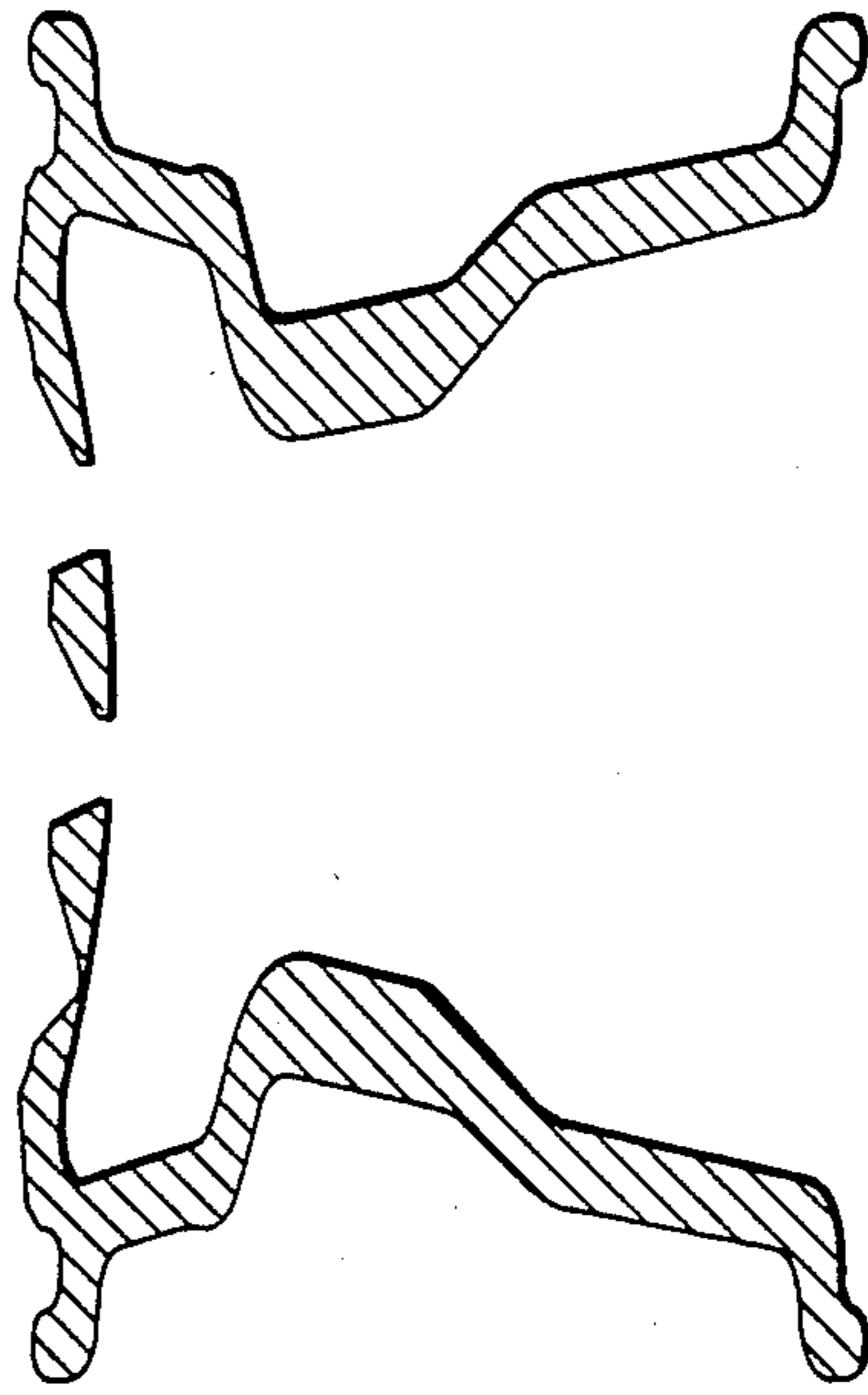

FIG. 5.