

[54] **WEATHER-PROTECTED REAR VIEW MIRROR**

[76] **Inventor: David L. Clark, P.O. Box 105, Brookings, Oreg. 97415**

[**] **Term: 14 Years**

[21] **Appl. No.: 88,202**

[22] **Filed: Aug. 24, 1987**

[52] **U.S. Cl. D12/187; D12/189**

[58] **Field of Search D12/187, 189; 350/629, 350/631, 605, 600; 248/475.1, 479, 484, 485, 487**

[56] **References Cited**

U.S. PATENT DOCUMENTS

- D. 166,429 4/1952 Triphahn D12/187
- D. 249,340 9/1978 Braid D12/187
- D. 263,295 3/1982 Lauve D12/187

3,424,517 1/1969 Budreck D12/187

Primary Examiner—James M. Gandy
Attorney, Agent, or Firm—Marger & Johnson

[57] **CLAIM**

The ornamental design for a weather-protected rear view mirror, as shown and described.

DESCRIPTION

FIG. 1 is a left, front perspective view of a weather-protected rear view mirror showing my new design, it being understood that the broken lines are for illustrative purposes only and form no part of the claimed design;

FIG. 2 is a top plan view thereof;

FIG. 3 is a left side elevation view thereof;

FIG. 4 is a front elevation view thereof;

FIG. 5 is a right side elevation view thereof;

FIG. 6 is a bottom plan view thereof; and

FIG. 7 is a rear elevation view thereof.

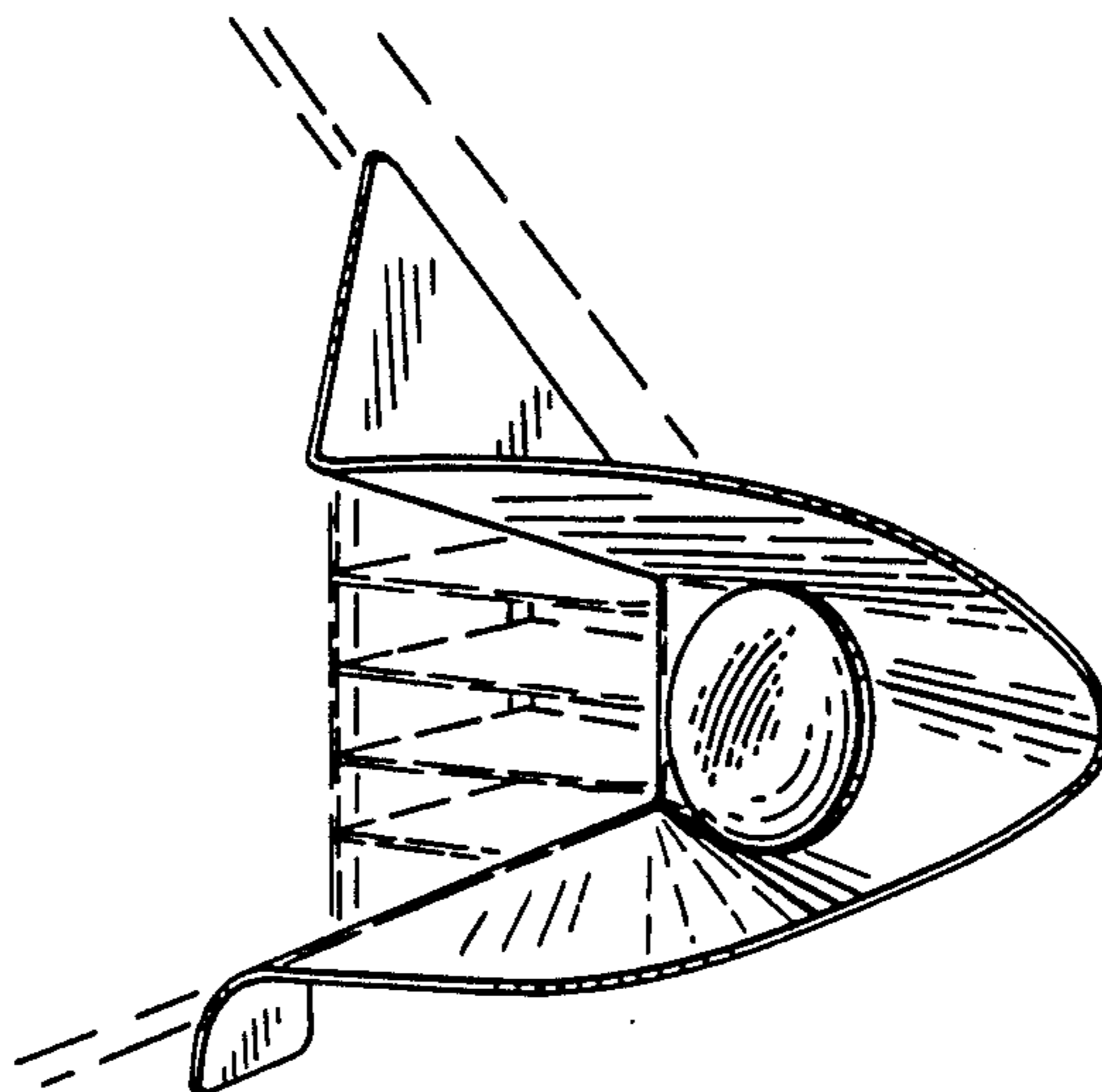

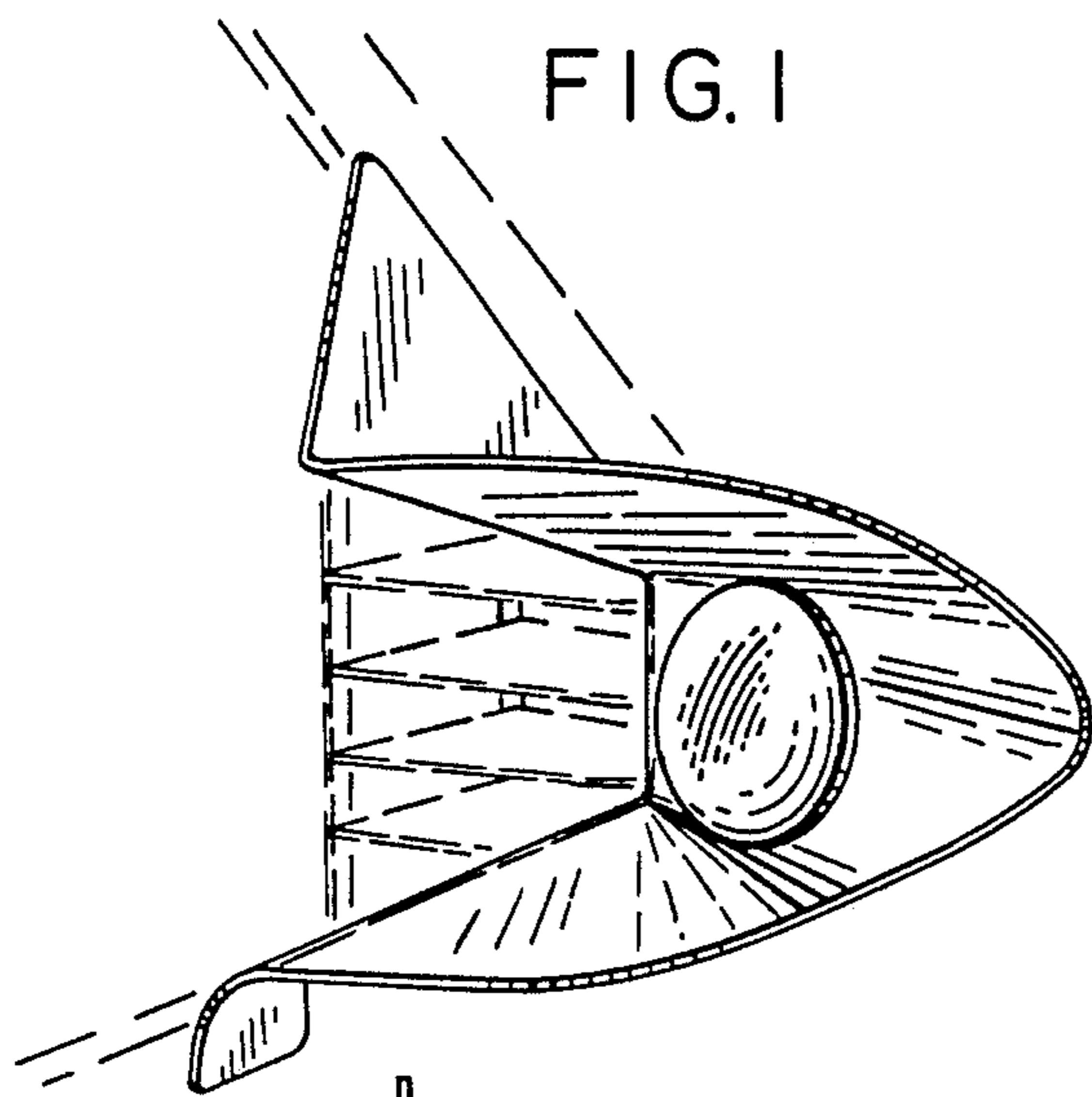

FIG. 1

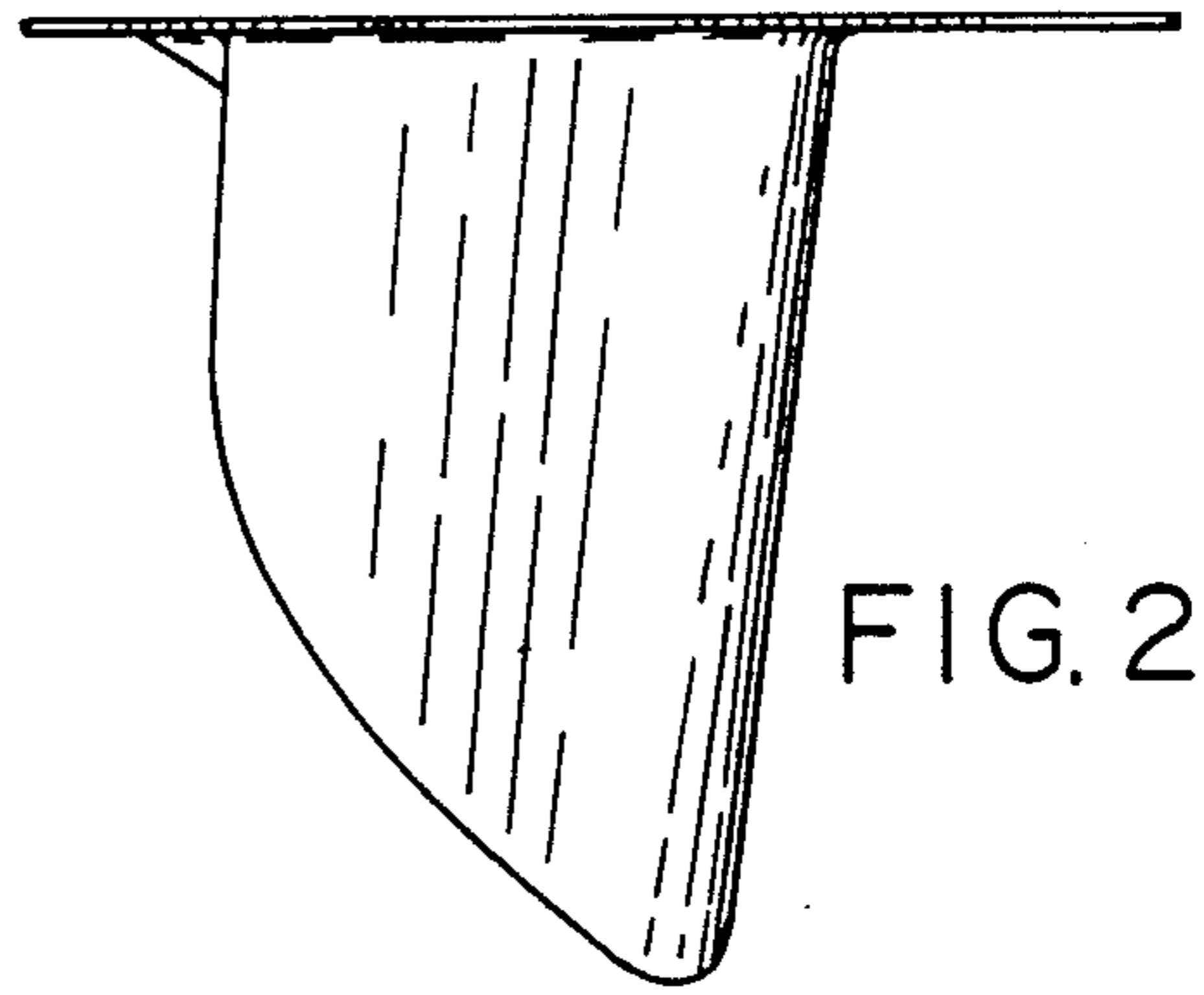

FIG. 2

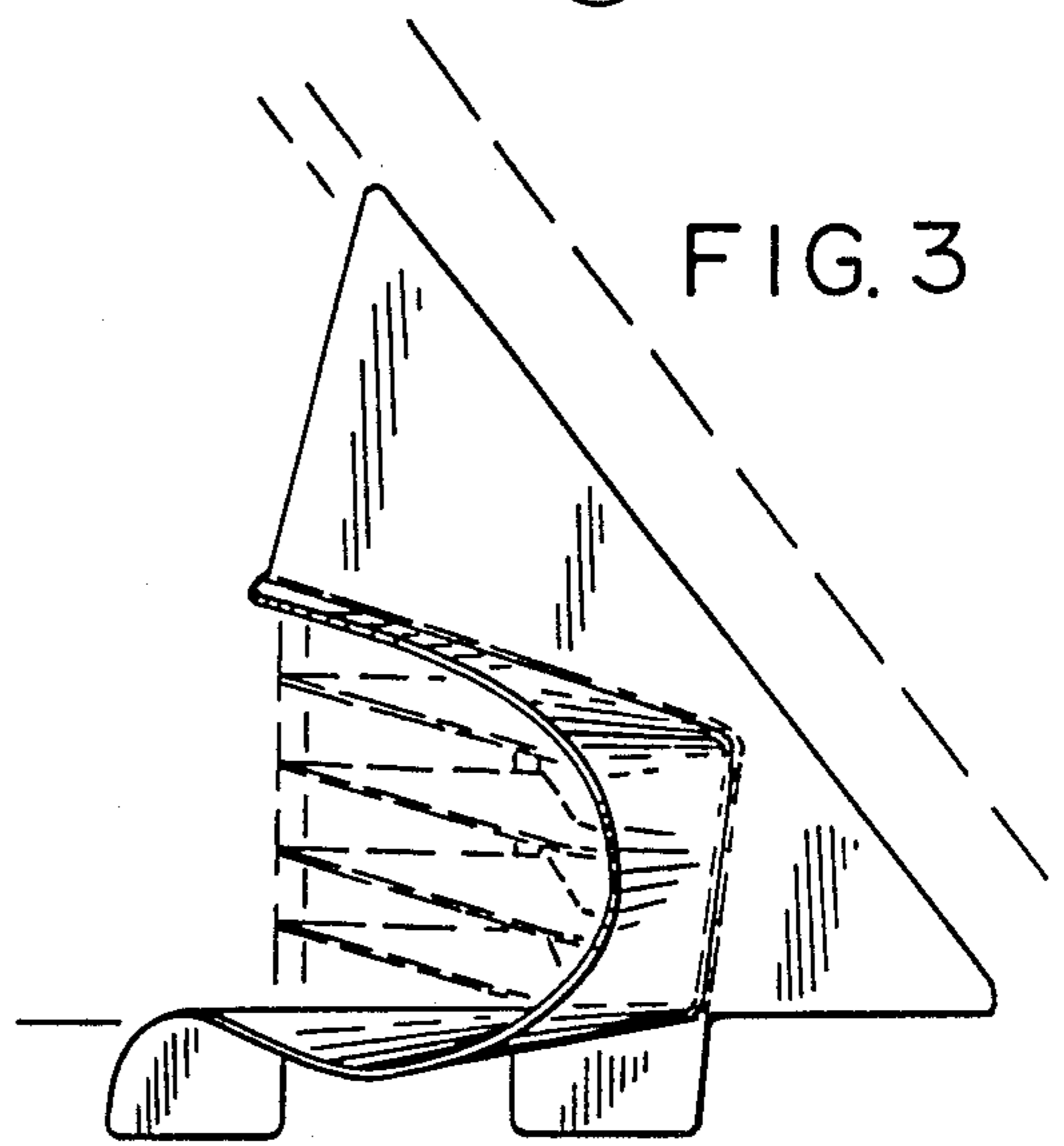

FIG. 3

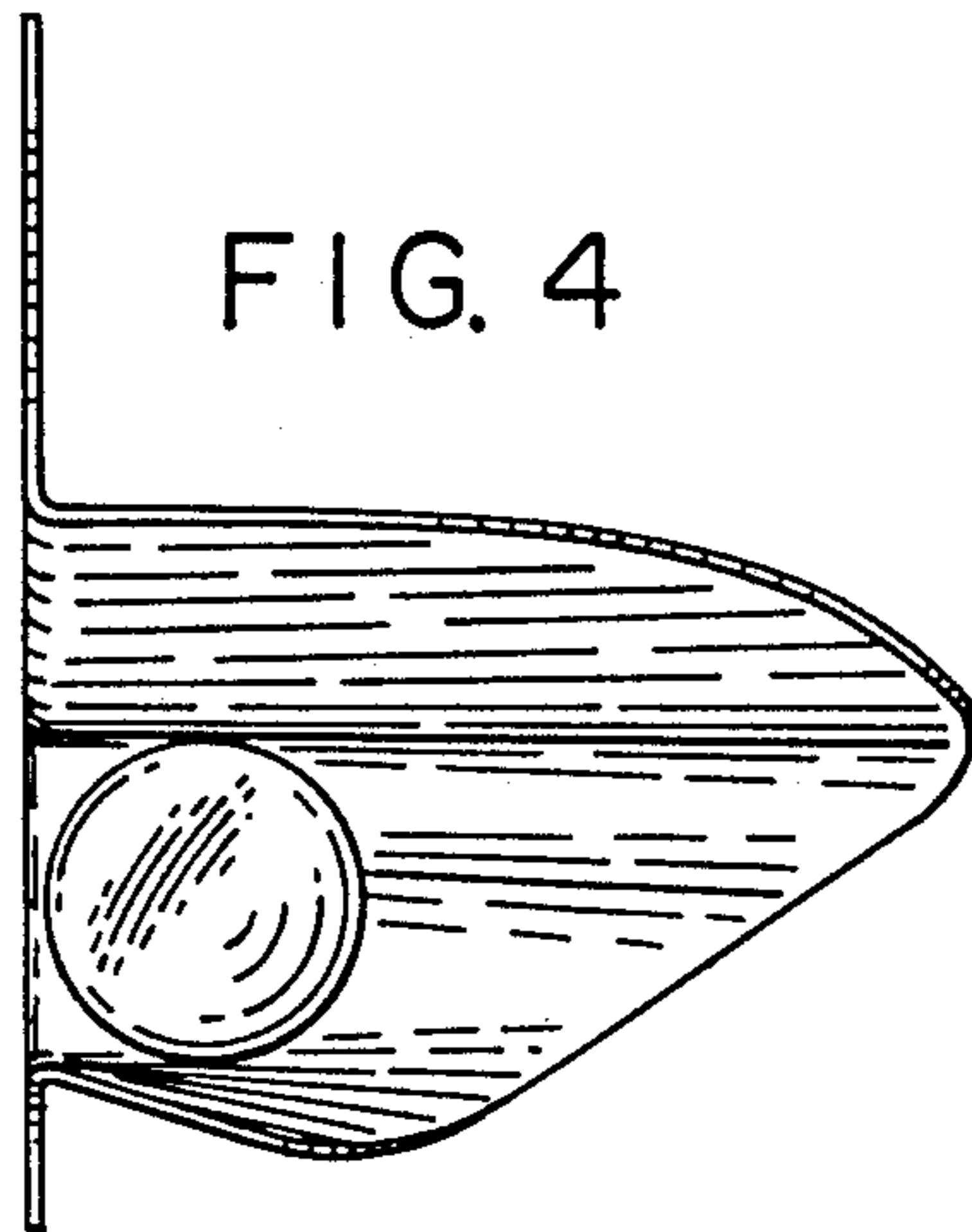

FIG. 4

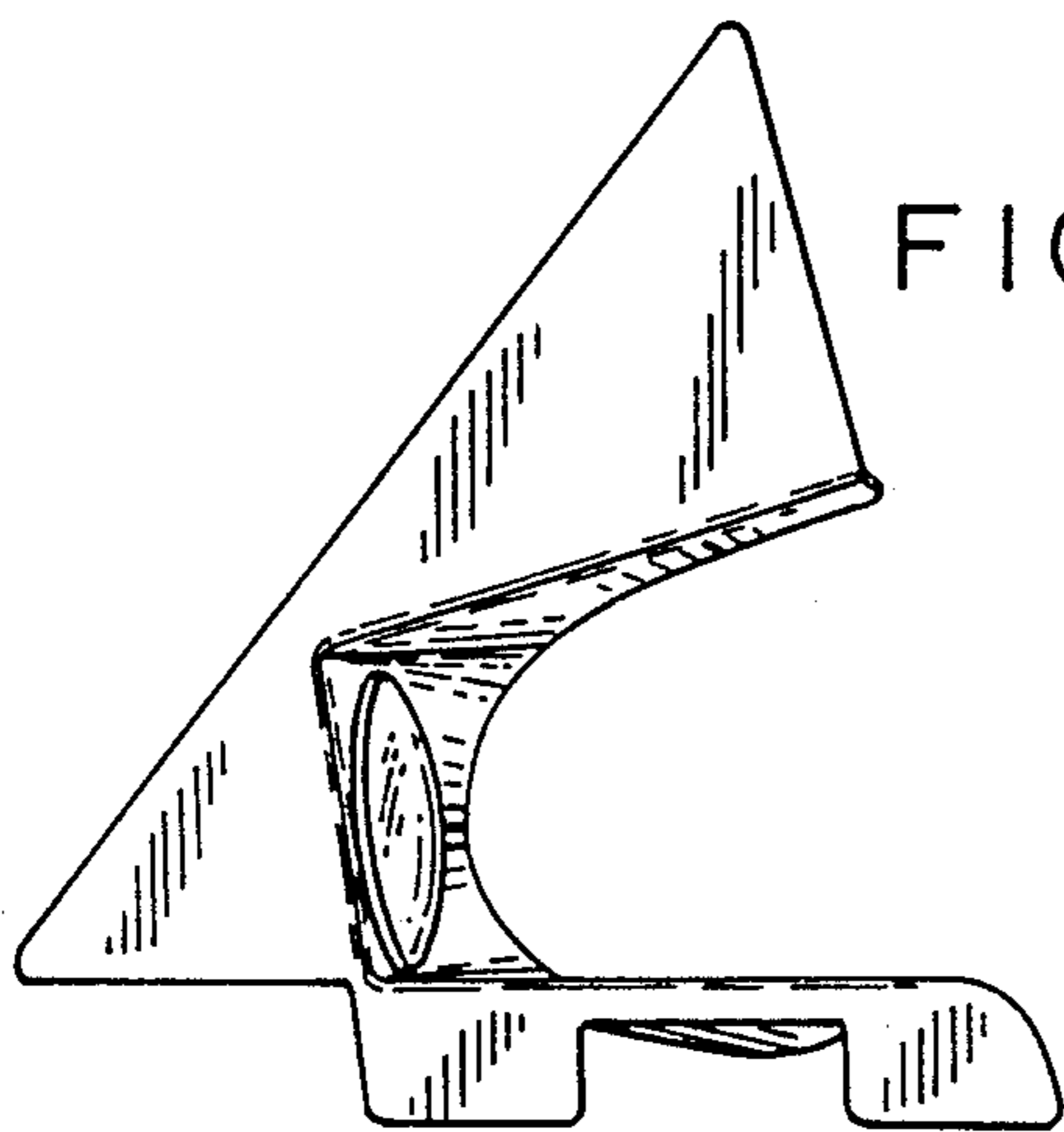

FIG. 5

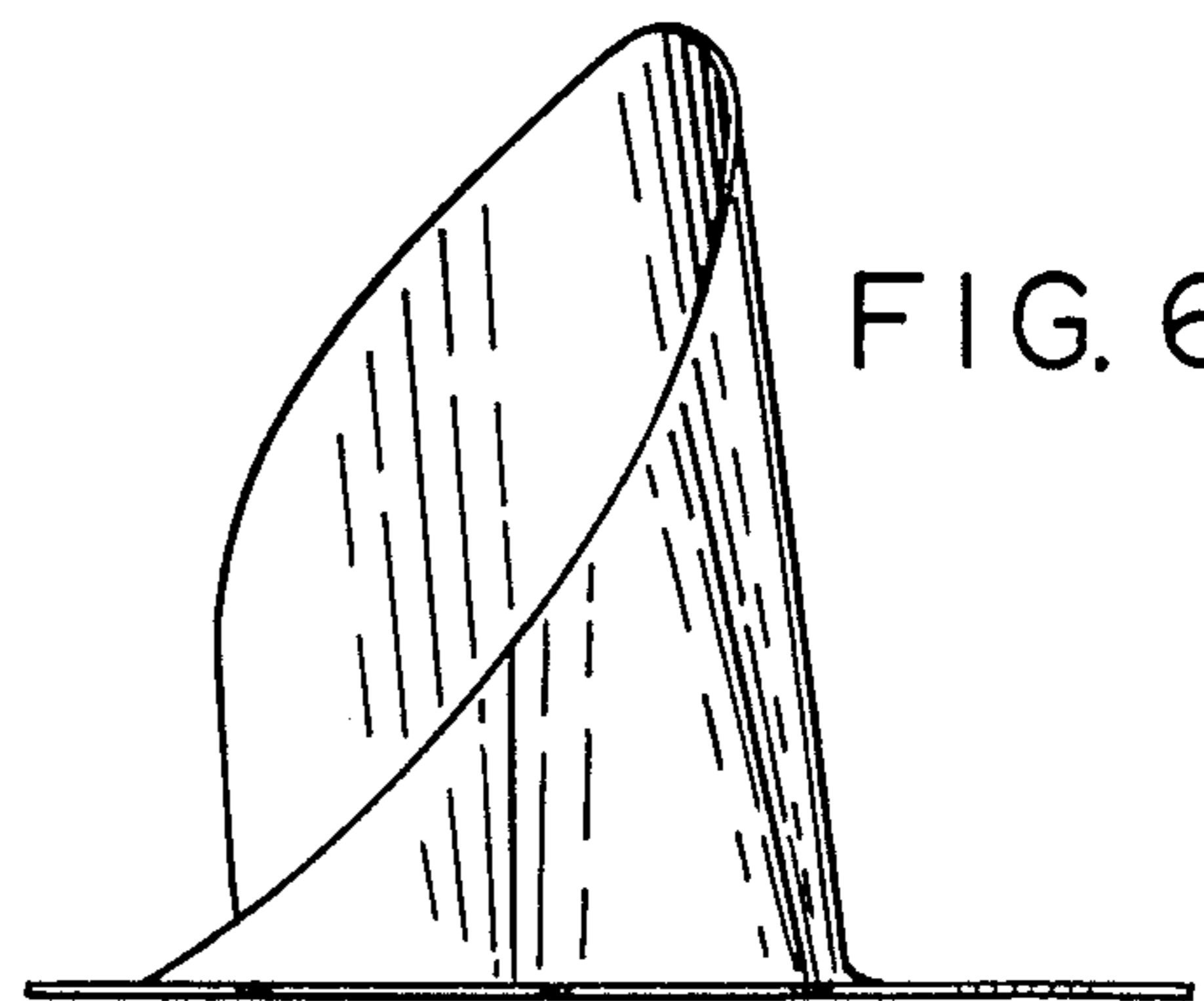

FIG. 6

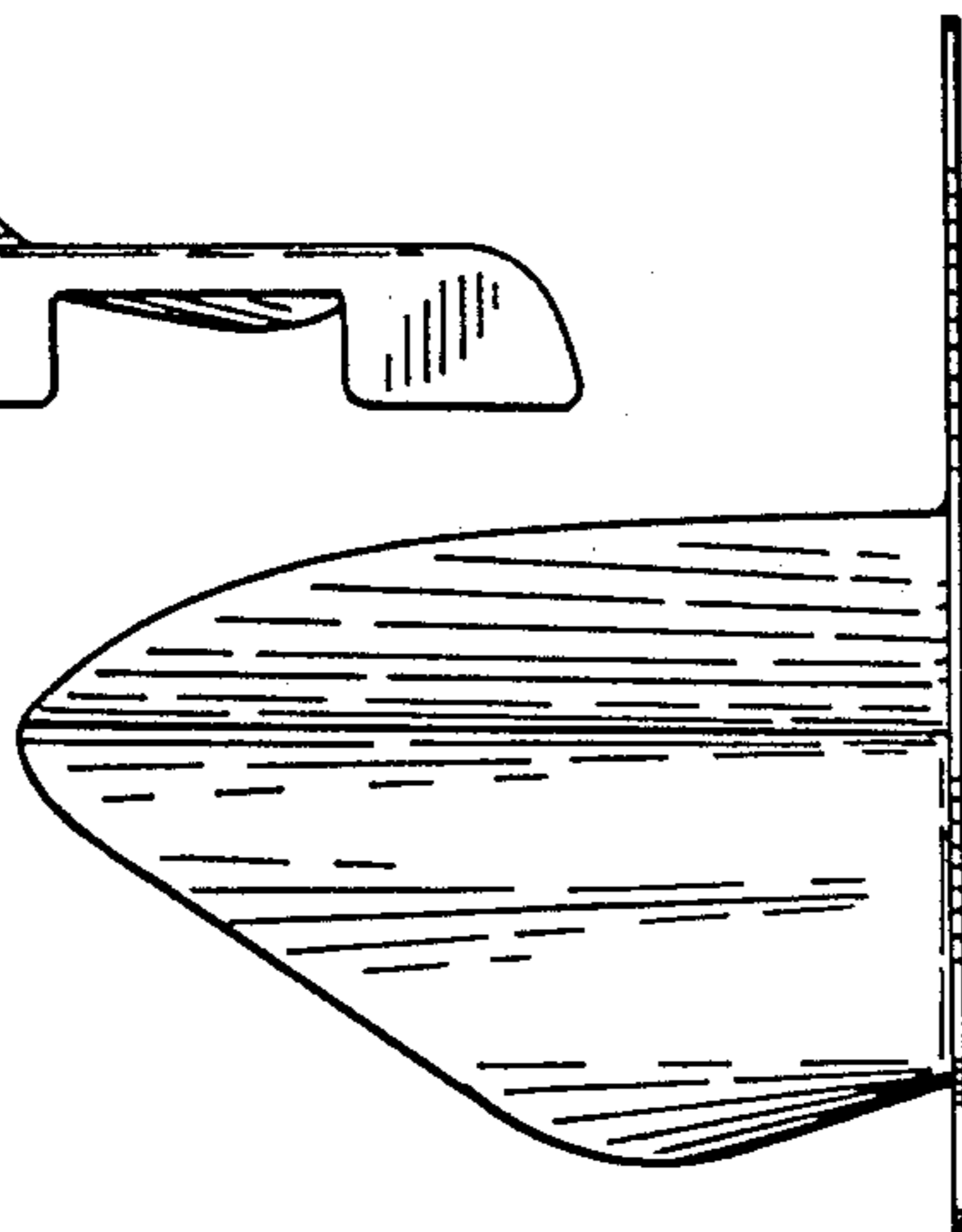

FIG. 7