

[54] **FLUSH MOUNTED LATCH ASSEMBLY**

[75] **Inventors: Richard H. Russell, Farmington; David W. Kaiser, North Haven, both of Conn.**

[73] **Assignee: The Eastern Company, Cleveland, Ohio**

[*] **Notice: The portion of the term of this patent subsequent to Sep. 26, 2003 has been disclaimed.**

[**] **Term: 14 Years**

[21] **Appl. No.: 72,573**

[22] **Filed: Jul. 10, 1987**

[52] **U.S. Cl. D8/306; D8/300; D8/331**

[58] **Field of Search D8/300, 302, 306-308, D8/322, 330-331, 336, 338, 346, 350, 353; 70/57, 63, 78, 84, 99, 101, 141**

[56] **References Cited**

U.S. PATENT DOCUMENTS

D. 196,424 10/1963 Are D10/8

D. 210,152 2/1968 Pastva D50/5

D. 210,153 2/1968 Pastva D50/5

D. 218,672 9/1970 Lauper D8/109

D. 230,132 1/1974 Pastva D8/109

D. 265,965 8/1982 Davis et al. D8/302

D. 270,328 8/1983 Davis et al. D8/302

D. 271,562 11/1983 Weinerman D8/338

D. 292,482 10/1987 Weinerman et al. D8/302

2,317,700 4/1943 Thompson 292/254

2,387,187 10/1945 Smith 70/97

2,594,940 4/1952 Levine 70/66

2,637,585 5/1953 Troche et al. 292/336.3

2,642,300 6/1953 Pelcin 292/173

2,649,322 8/1953 Mack 292/173

2,668,076 2/1954 Troche et al. 292/336.3

2,721,751 10/1955 Holritz 292/169

2,735,706 2/1956 Pelcin 292/34

2,746,784 3/1956 Holritz 292/175

2,763,503 9/1956 Tasch et al. 292/173

2,784,993 3/1957 Collar 292/223

2,840,407 6/1958 Sellon, Jr. 292/169

2,871,048 1/1959 Balogh 292/173

2,900,204 8/1959 Pelcin 292/173

2,916,905 12/1959 Podlesak 70/150

2,987,080 6/1961 Pelcin 70/146

3,044,287 7/1962 Pelcin 70/99

3,044,814 7/1962 Pelcin 292/126

3,055,204 9/1962 Pelcin 70/153

3,081,617 3/1963 McKay 70/153

3,209,563 10/1965 Pelcin 70/146

3,209,564 10/1965 Pelcin 70/148

3,338,610 8/1967 Pelcin et al. 292/126

3,357,734 12/1967 Pastva, Jr. 292/165

3,371,511 3/1968 Atkinson 70/71

3,389,932 6/1968 Pastva, Jr. 292/173

3,449,005 6/1969 Pastva, Jr. 292/173

3,495,862 2/1970 McClintock 292/173

3,576,118 4/1971 Doerrfeld 70/146

3,668,907 6/1972 Pastva, Jr. 70/153

3,707,862 1/1973 Pastva, Jr. 70/150

3,743,336 7/1973 Andrews 292/173

3,758,140 9/1973 Prete, Jr. 292/223

3,782,141 1/1974 Doerrfeld 70/146

3,795,416 3/1974 Hehl et al. 292/336.3

3,841,674 10/1974 Bisbing et al. 292/175

3,850,464 11/1974 Bisbing et al. 292/175

3,857,594 12/1974 Pastva, Jr. 292/27

3,871,198 3/1975 Miller 70/146

4,038,718 8/1977 Reilhac et al. 16/110

4,116,027 9/1978 Tannery 70/472

4,131,002 12/1978 Gianelo 70/84

4,134,281 1/1979 Pelcin 70/208

4,138,869 2/1979 Pelcin 70/151

4,170,119 10/1979 Kalis, Jr. 70/221

4,177,656 12/1979 Davis 70/84

4,231,597 11/1980 Pelcin 292/164

4,309,884 1/1982 Davis 70/472

4,312,202 1/1982 Pastva, Jr. et al. 70/472

4,312,203 1/1982 Davis 70/472

4,312,204 1/1982 Davis 70/472

4,312,205 1/1982 Reed et al. 70/472

4,320,642 3/1982 Pastva, Jr. 70/472

4,321,812 3/1982 Pelcin 70/472

4,335,595 6/1982 Swan et al. 70/149

4,370,874 2/1983 Munn 70/204

4,413,849 11/1983 Davis et al. 292/229

4,420,954 12/1983 Hieronymi et al. 70/150

4,438,964 3/1984 Peters 292/216

4,465,328 8/1984 Tihanyi et al. 312/215

4,492,394 1/1985 Dignan 292/64

4,578,968 4/1986 Messier, Jr. 70/208

4,671,547 6/1987 Weinerman et al. 292/197

4,679,835 7/1987 Weinerman et al. 292/197

4,683,736 8/1987 Weinerman et al. 70/208

4,706,478 11/1987 Swan et al. 70/208

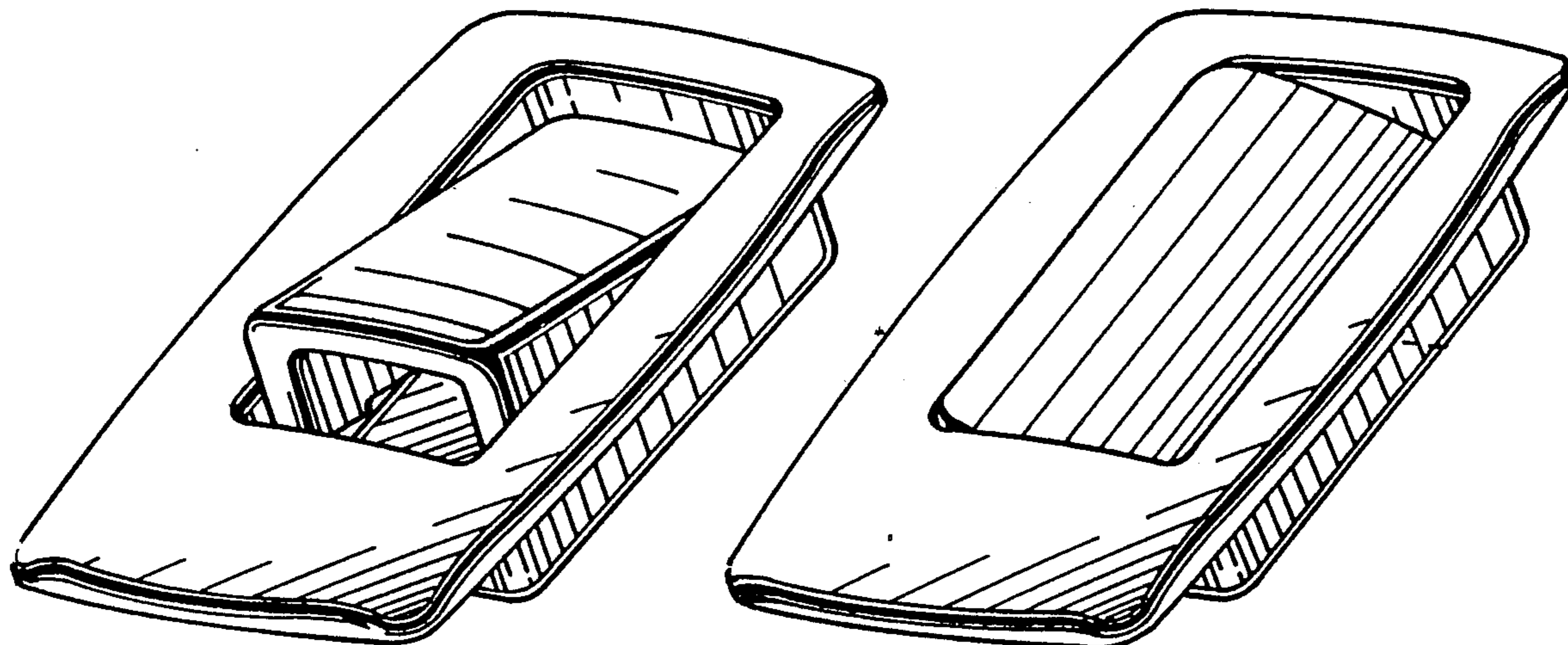

OTHER PUBLICATIONS

Southco Inc., *Southco Fasteners Handbook 37*, Concordville, PA 19331, date unknown.

Eberhard Manufacturing Co., *Handbook of Latches, Locks, Hinges, Handles, and Related Hardware*, No. 103, Cleveland, OH 44136, 1985.

Adams Rite Manufacturing Co., *Hardware for Glass Doors That Swing or Slide*, City of Industry, CA 91749, Jan., 1988.

Primary Examiner—Wallace R. Burke

Assistant Examiner—Brian N. Vinson

Attorney, Agent, or Firm—David A. Burge

[57]

CLAIM

The ornamental design for a flush mounted latch assembly, as shown and described.

DESCRIPTION

FIG. 1 is a front perspective view of a flush mounted latch assembly showing our new design;

FIG. 2 is a front elevational view thereof;

FIG. 3 is a rear elevational view thereof;

FIG. 4 is a bottom plan view thereof;

FIG. 5 is a top plan view thereof;

FIG. 6 is a right side elevational view thereof;

FIG. 7 is a left side elevational view thereof;

FIG. 8 is a vertical cross-sectional view thereof, taken along line 8—8 of FIG. 2;

FIG. 9 is a vertical cross-sectional view thereof, taken along line 9—9 of FIG. 3;

FIG. 10 is a rear perspective view thereof;

FIG. 11 is a rear, fragmentary perspective view thereof, with portions omitted for clarity of illustration;

FIG. 12 is a front perspective view thereof, with the handle shown moved to an operating position;

FIG. 13 is a vertical cross-sectional view thereof taken along line 13—13 of FIG. 12, with the handle shown moved to an operating position;

FIG. 14 is a top perspective view of a second embodiment thereof;

FIG. 15 is a front elevational view of the embodiment of FIG. 14;

FIG. 16 is a rear elevational view of the embodiment of FIG. 14;

FIG. 17 is a bottom plan view of the embodiment of FIG. 14;

FIG. 18 is a top plan view of the embodiment of FIG. 14;

FIG. 19 is a right side elevational view of the embodiment of FIG. 14;

FIG. 20 is a left side elevational view of the embodiment of FIG. 14;

FIG. 21 is a front elevational view of a third embodiment thereof, the only difference from the embodiment of FIG. 14 residing in the inclusion of a hex tool receiving aperture in the operator element;

FIG. 22 is a front elevational view of a fourth embodiment thereof, the only difference from the embodiment of FIG. 14 residing in the inclusion of a screwdriver blade receiving aperture in the operator element;

FIG. 23 is a front elevational view of a fifth embodiment thereof, the only difference from the embodiment of FIG. 14 residing in the inclusion of a key receiving aperture in the operator element;

FIG. 24 is a top perspective view of a sixth embodiment thereof;

FIG. 25 is a front elevational view of the embodiment of FIG. 24;

FIG. 26 is a rear elevational view of the embodiment of FIG. 24;

FIG. 27 is a bottom plan view of the embodiment of FIG. 24;

FIG. 28 is a top plan view of the embodiment of FIG. 24;

FIG. 29 is a right side elevational view of the embodiment of FIG. 24;

FIG. 30 is a left side elevational view of the embodiment of FIG. 24;

FIG. 31 is a vertical cross-sectional view of the embodiment of FIG. 24 taken along line 31—31 of FIG. 25;

FIG. 32 is a vertical cross-sectional view of the embodiment of FIG. 24 taken along line 32—32 of FIG. 25;

FIG. 33 is a rear perspective view of the embodiment of FIG. 24;

FIG. 34 is a rear, fragmentary perspective view of the embodiment of FIG. 24, with portions omitted for clarity of illustration;

FIG. 35 is a front perspective view of the embodiment of FIG. 24 with the handle shown moved to an operating position;

FIG. 36 is a horizontal cross-sectional view of the embodiment of FIG. 24 taken along line 36—36 of FIG. 35, with the handle shown moved to an operating position;

FIG. 37 is a top perspective view of a seventh embodiment thereof;

FIG. 38 is a front elevational view of the embodiment of FIG. 37;

FIG. 39 is a rear elevational view of the embodiment of FIG. 37;

FIG. 40 is a bottom plan view of the embodiment of FIG. 37;

FIG. 41 is a top plan view of the embodiment of FIG. 37;

FIG. 42 is a right side elevational view of the embodiment of FIG. 37;

FIG. 43 is a left side elevational view of the embodiment of FIG. 37;

FIG. 44 is a front elevational view of an eighth embodiment thereof, the only difference from the embodiment of FIG. 37 residing in the inclusion of a hex tool receiving aperture in the operator element;

FIG. 45 is a front elevational view of a ninth embodiment thereof, the only difference from the embodiment of FIG. 37 residing in the inclusion of a screwdriver blade receiving aperture in the operator element; and, FIG. 46 is a front elevational view of a tenth embodiment thereof, the only difference from the embodiment of FIG. 37 residing in the inclusion of a key receiving aperture in the operator element.

The broken line showing in FIGS. 14, 16-20, 37 and 39-43 of mounting elements that extend rearwardly from the housing is for illustrative purposes only and forms no part of the claimed design.

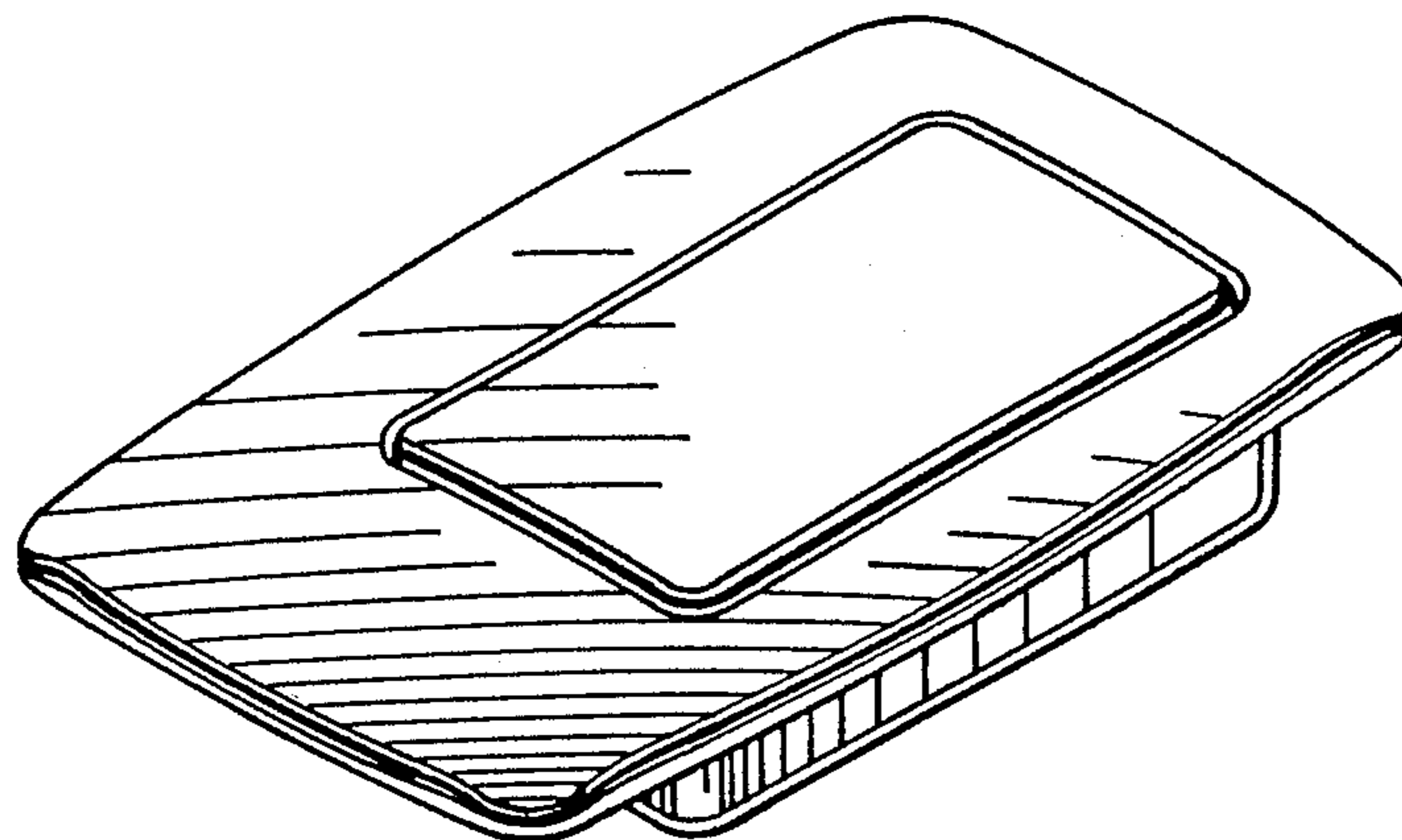

FIG. 1

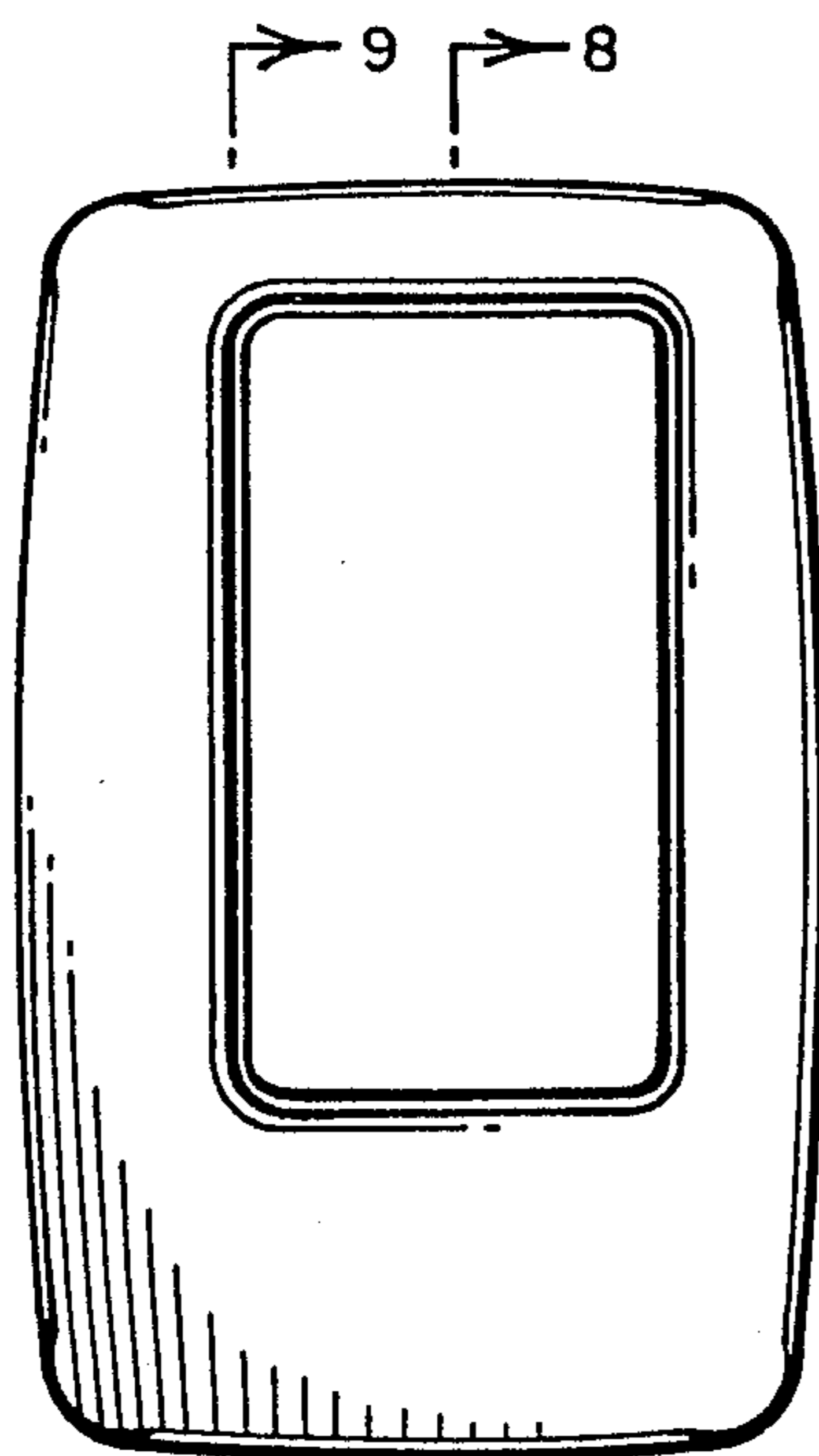

FIG. 2

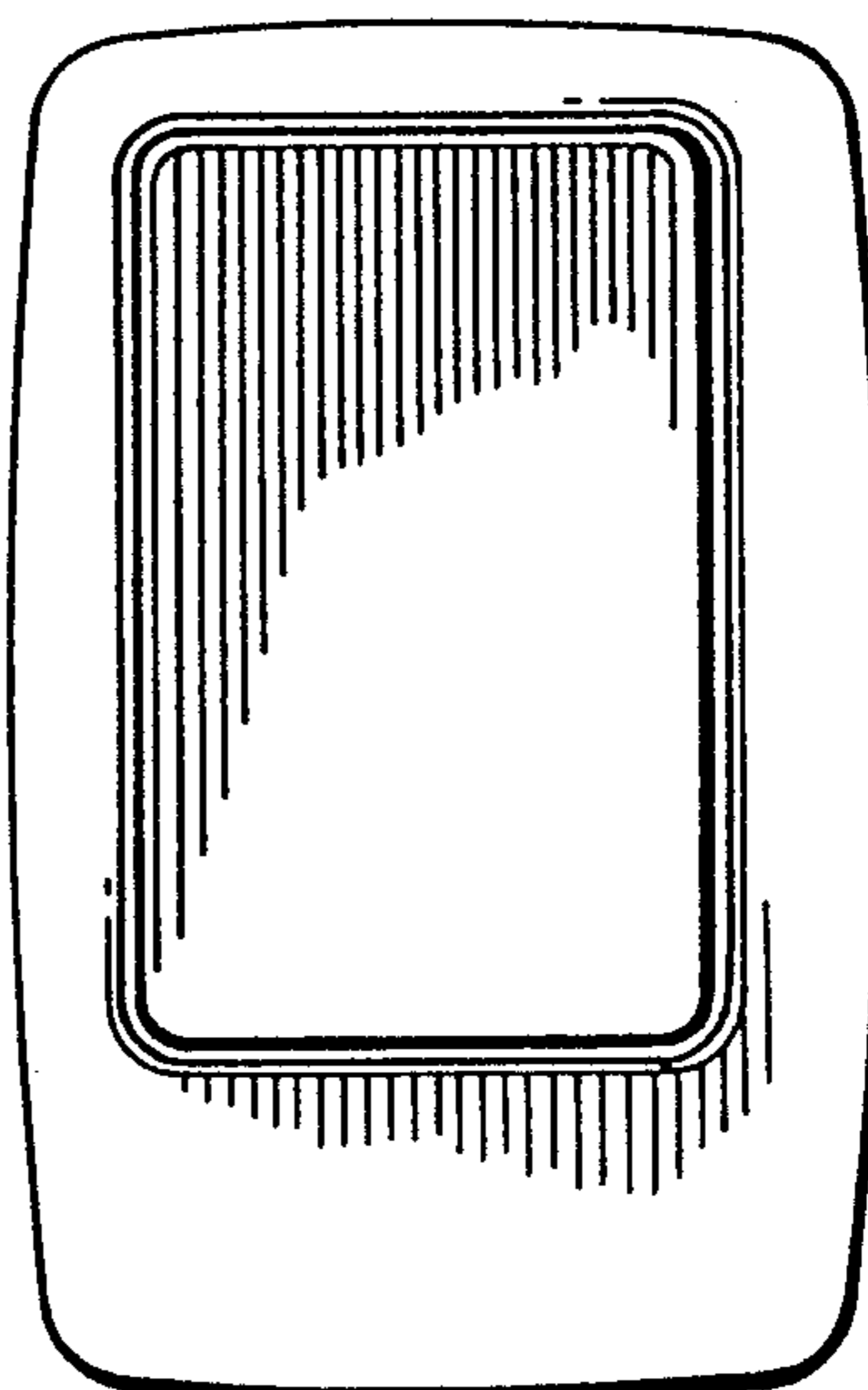

FIG. 3

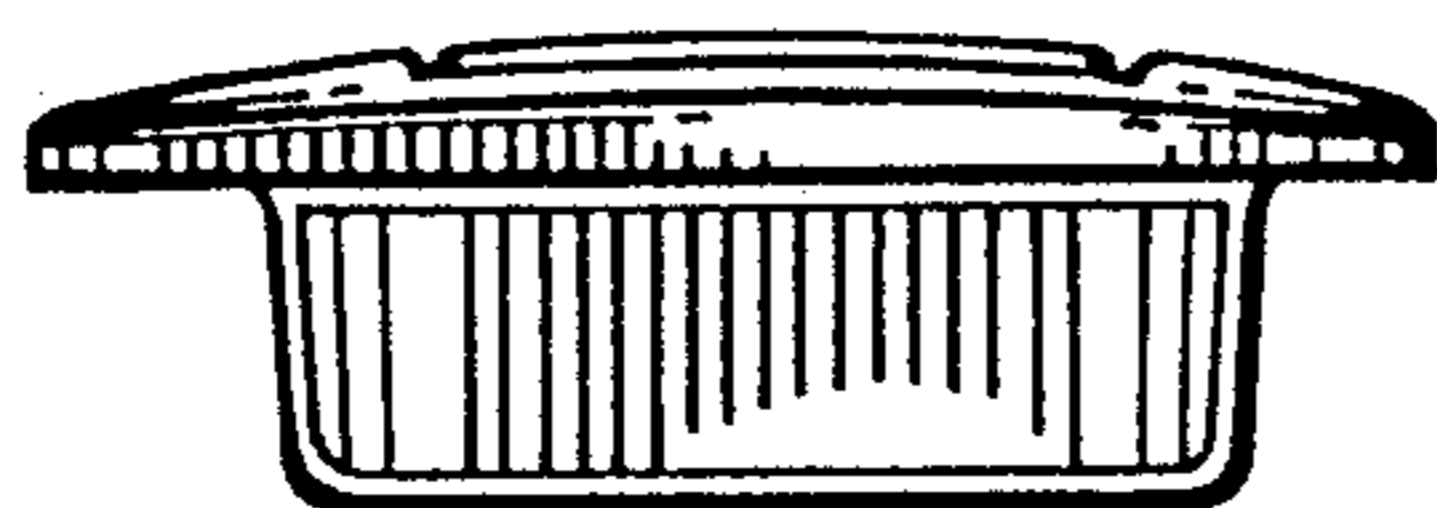

FIG. 4



FIG. 5

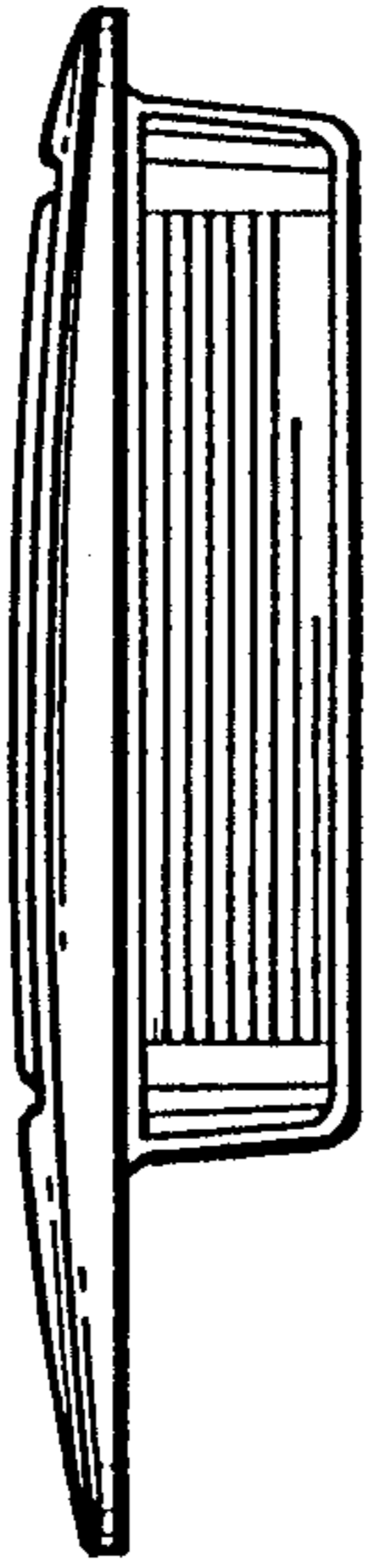

FIG. 6



FIG. 7



FIG. 8

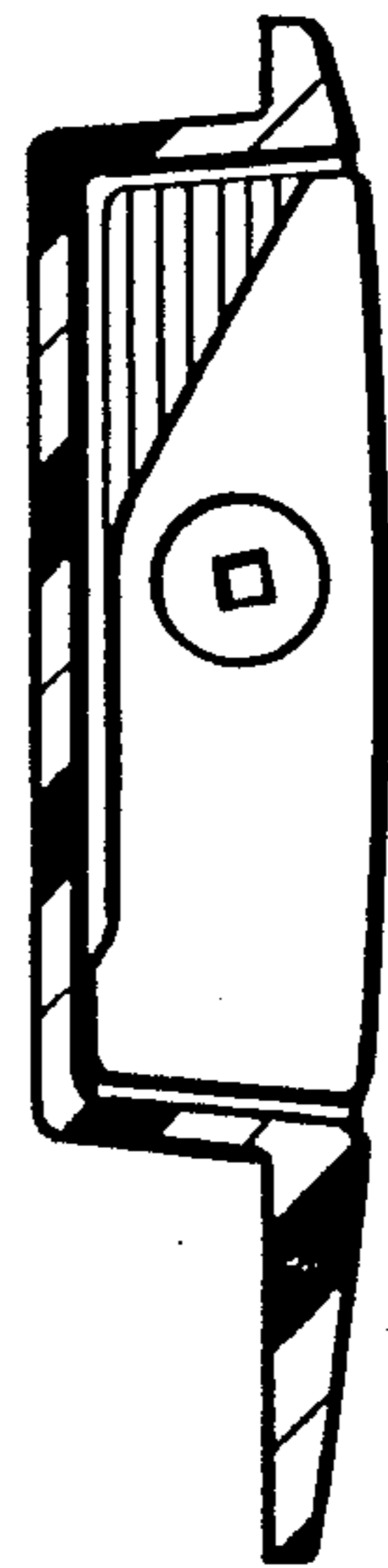

FIG. 9

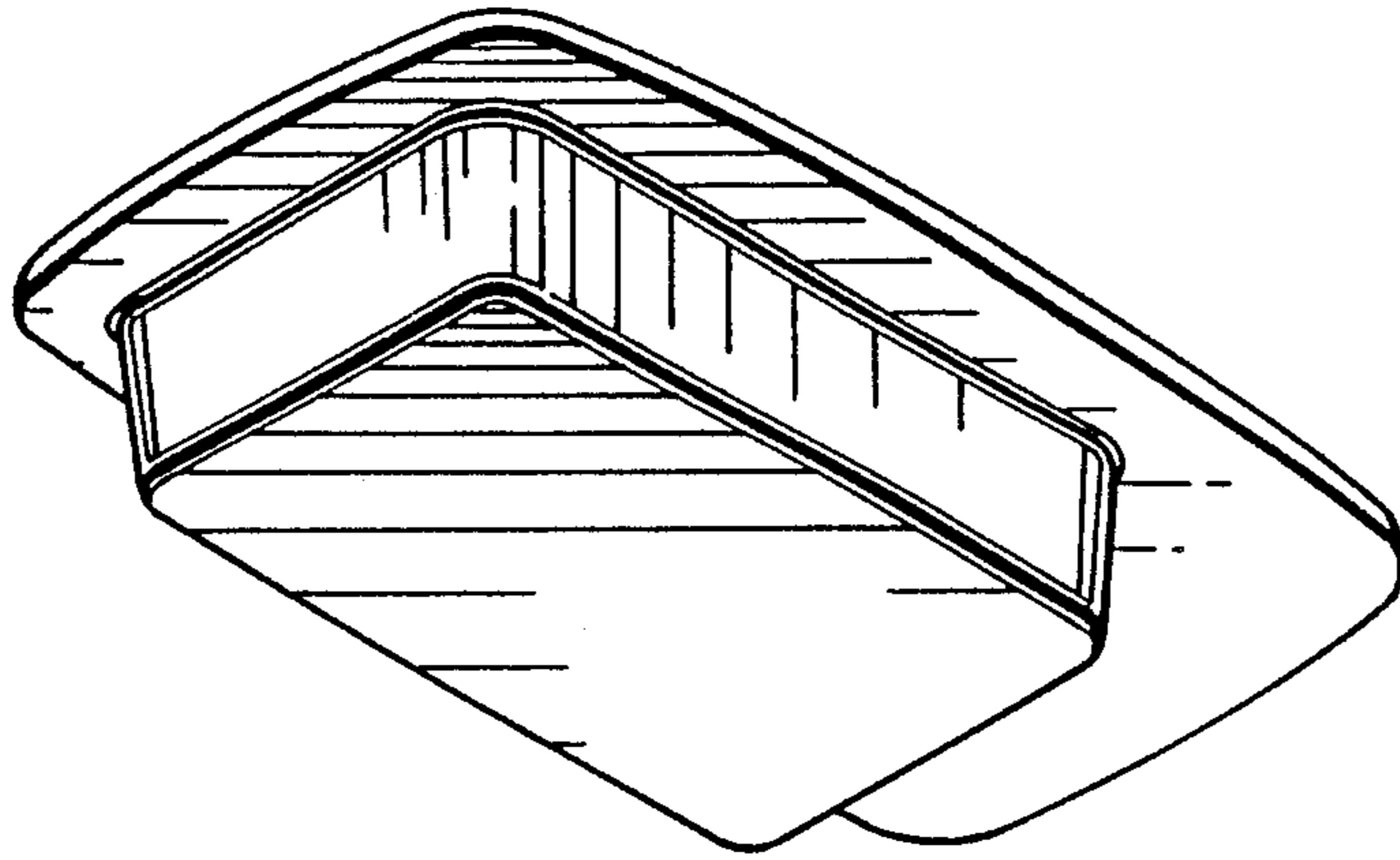

FIG. 10

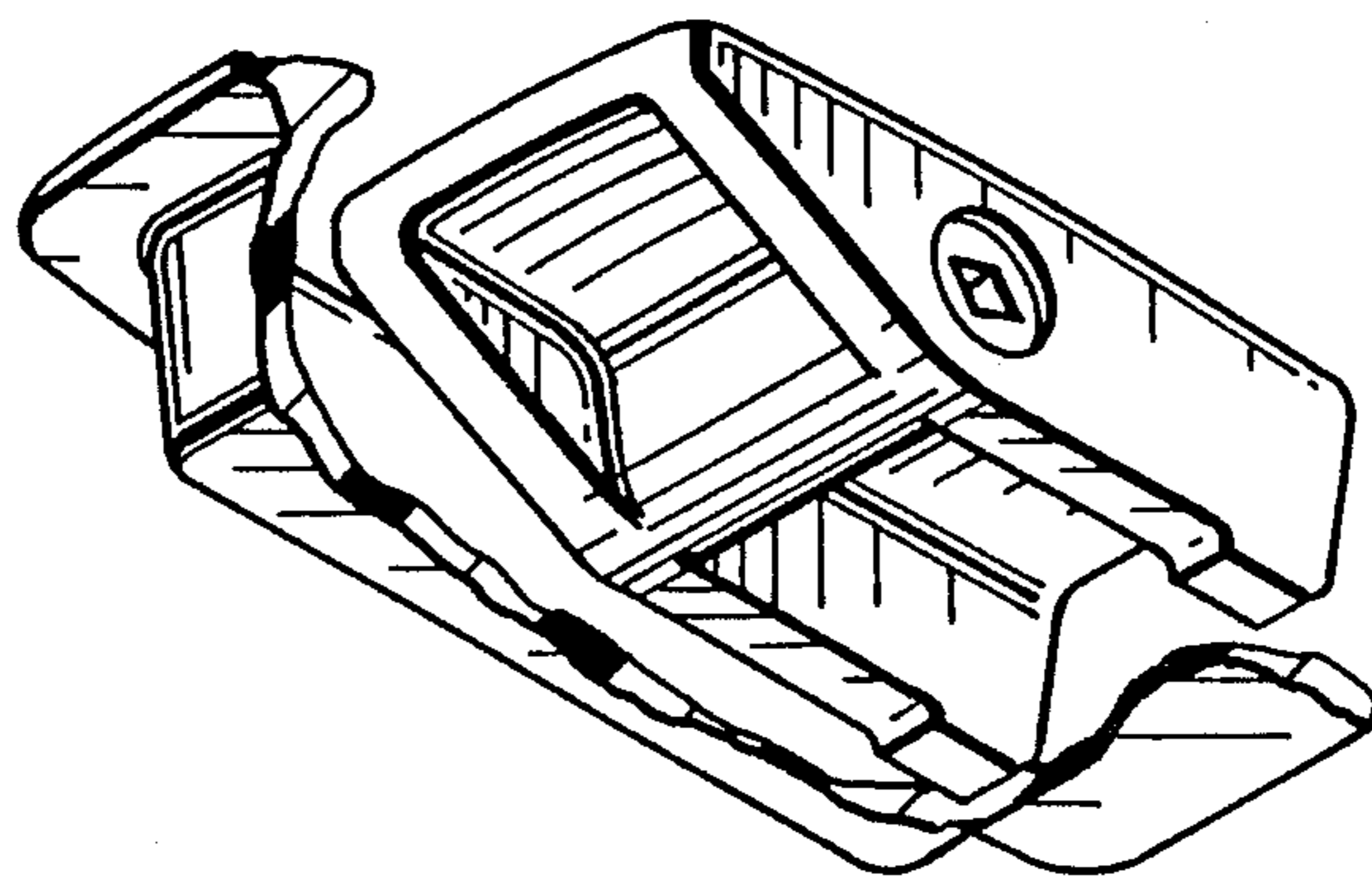

FIG. 11

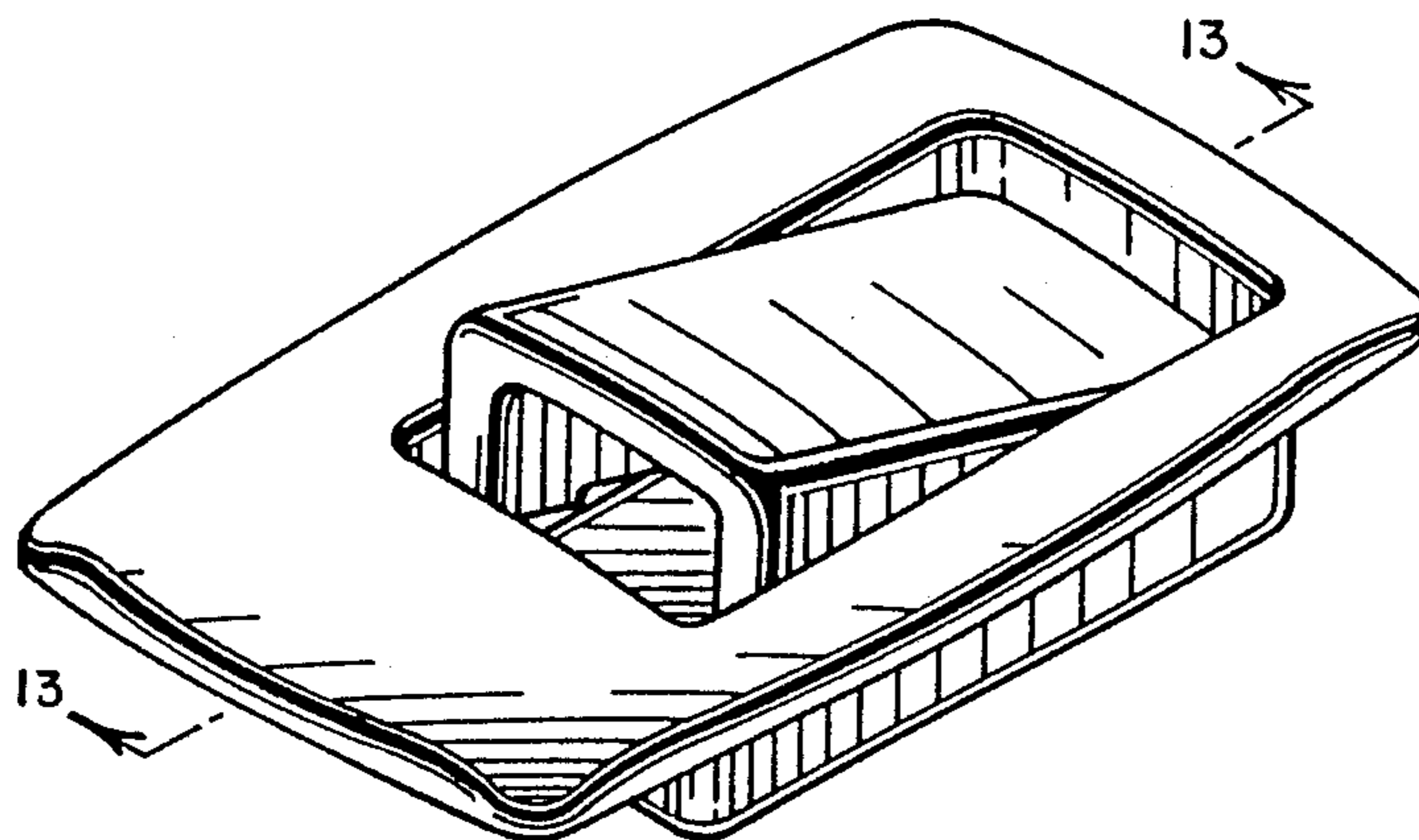

FIG. 12



FIG. 13

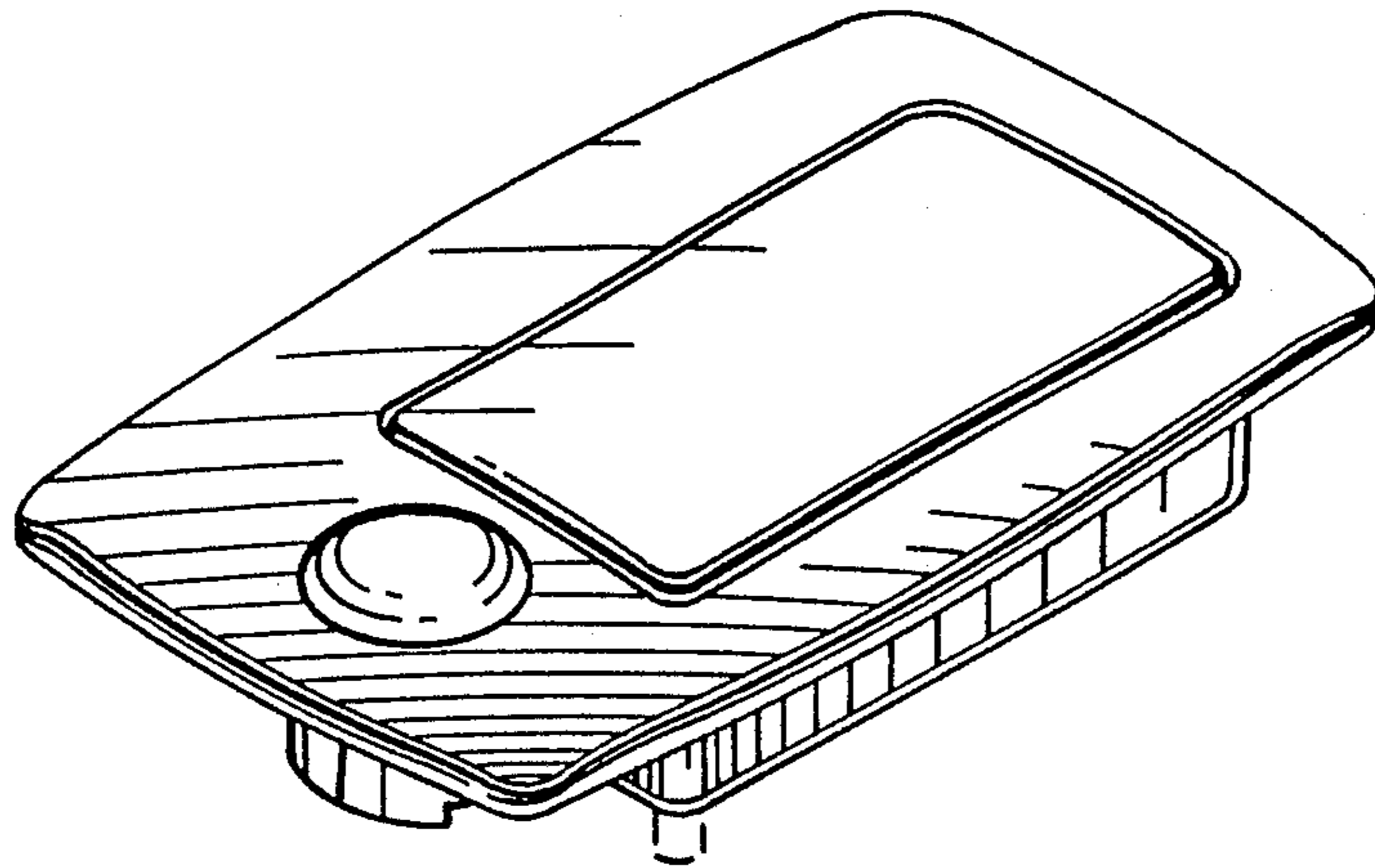

FIG. 14

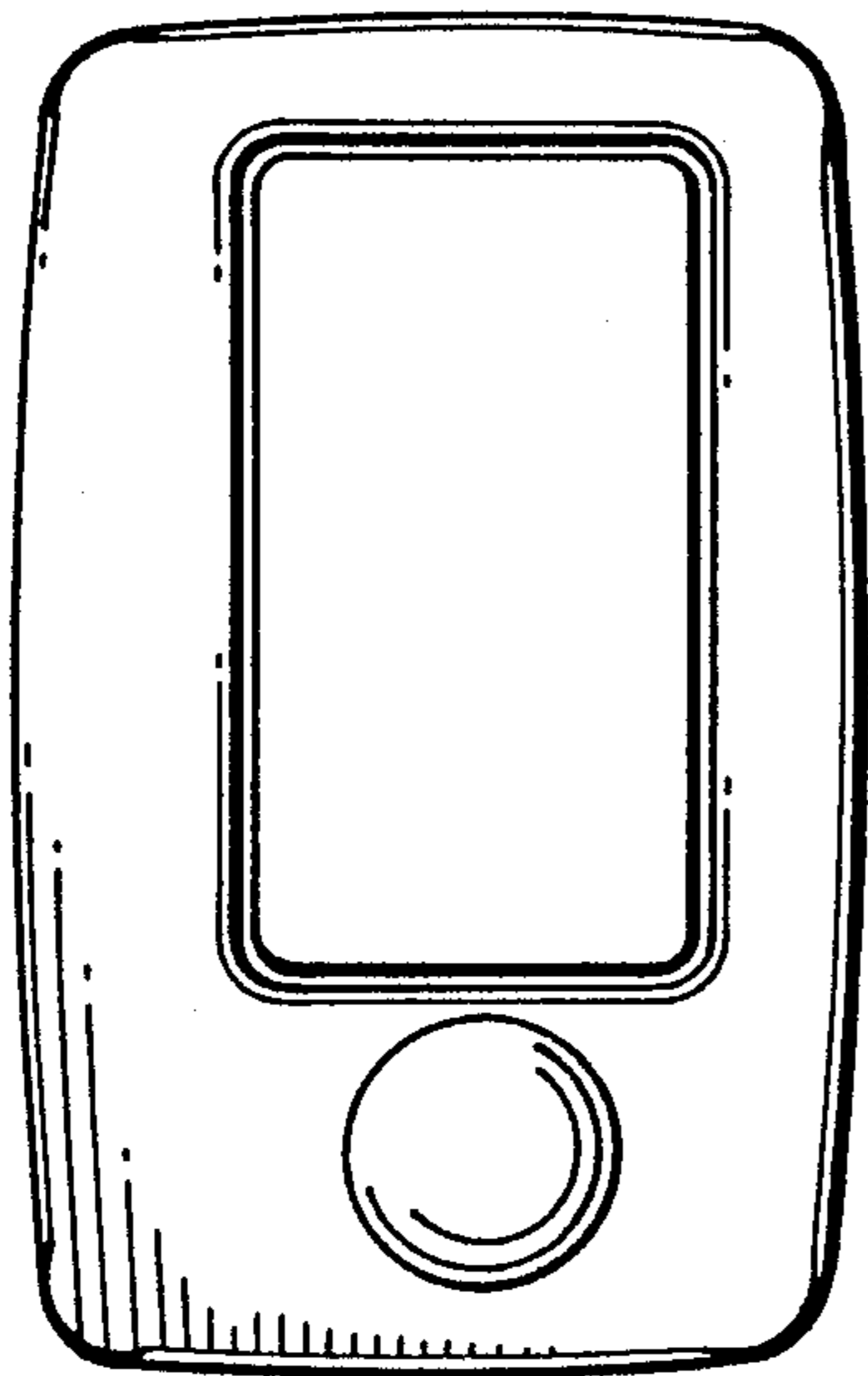

FIG. 15

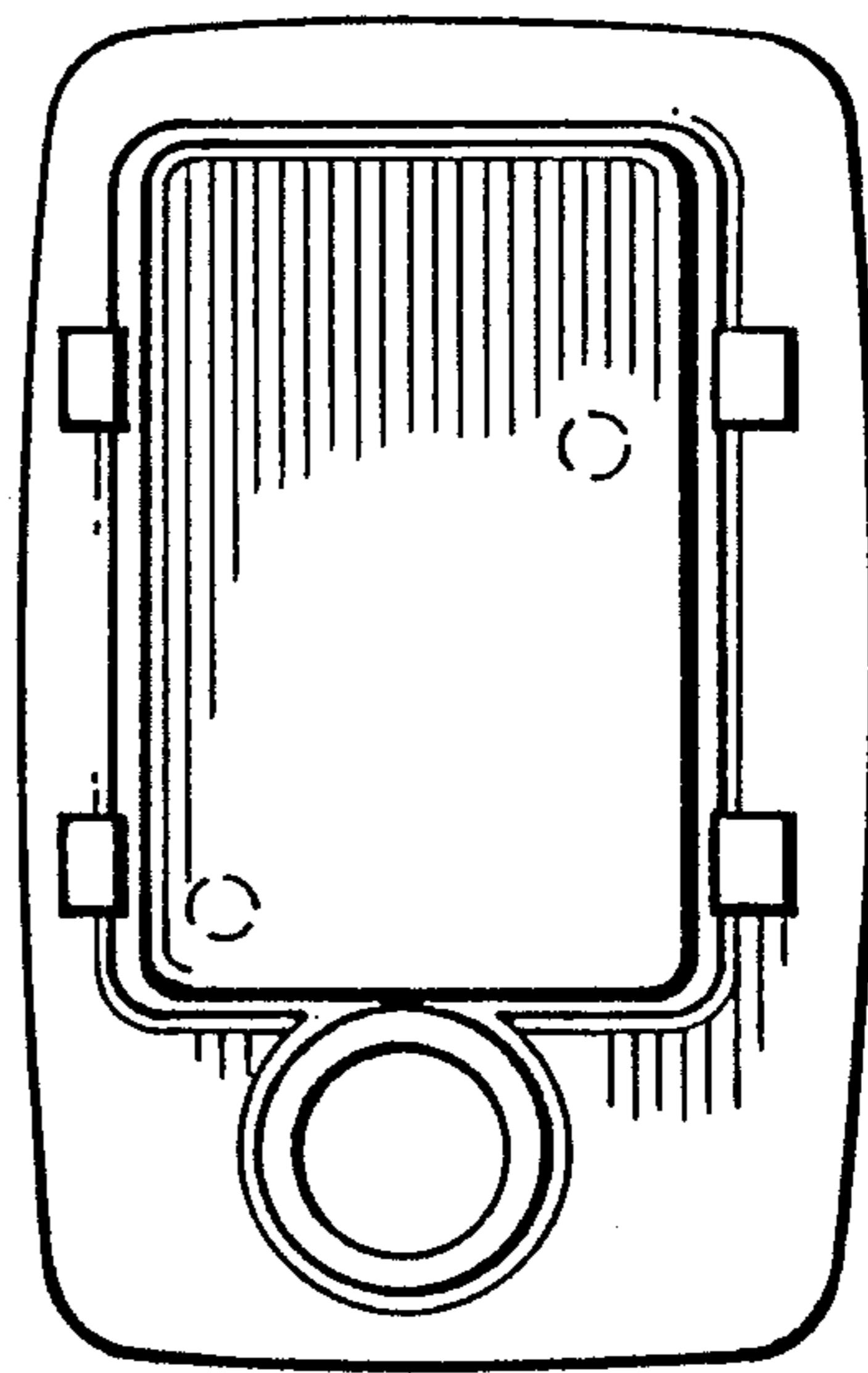

FIG. 16

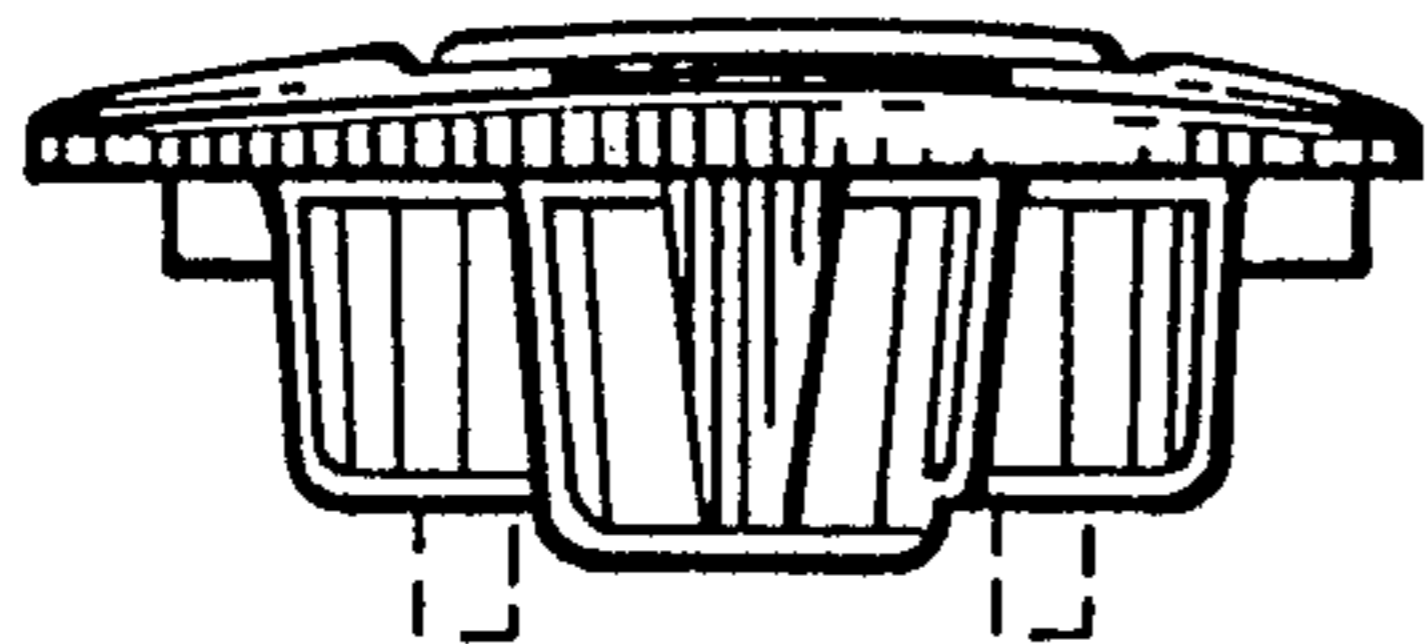

FIG. 17

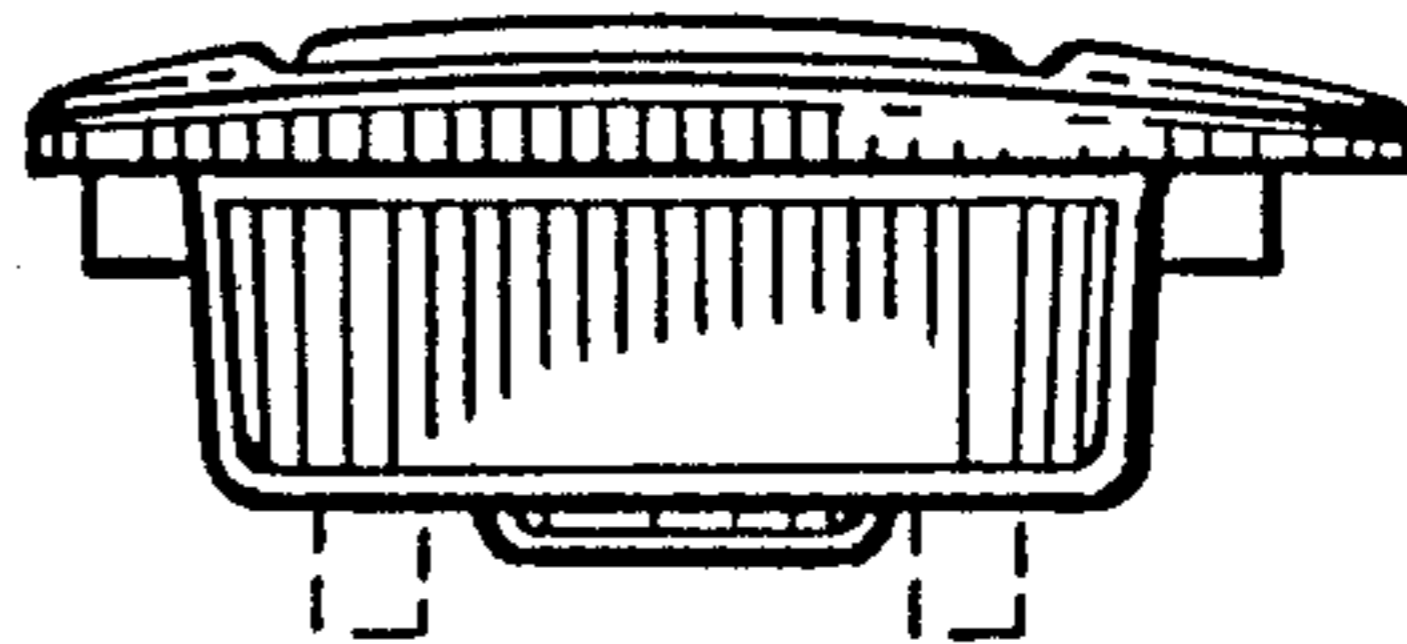

FIG. 18

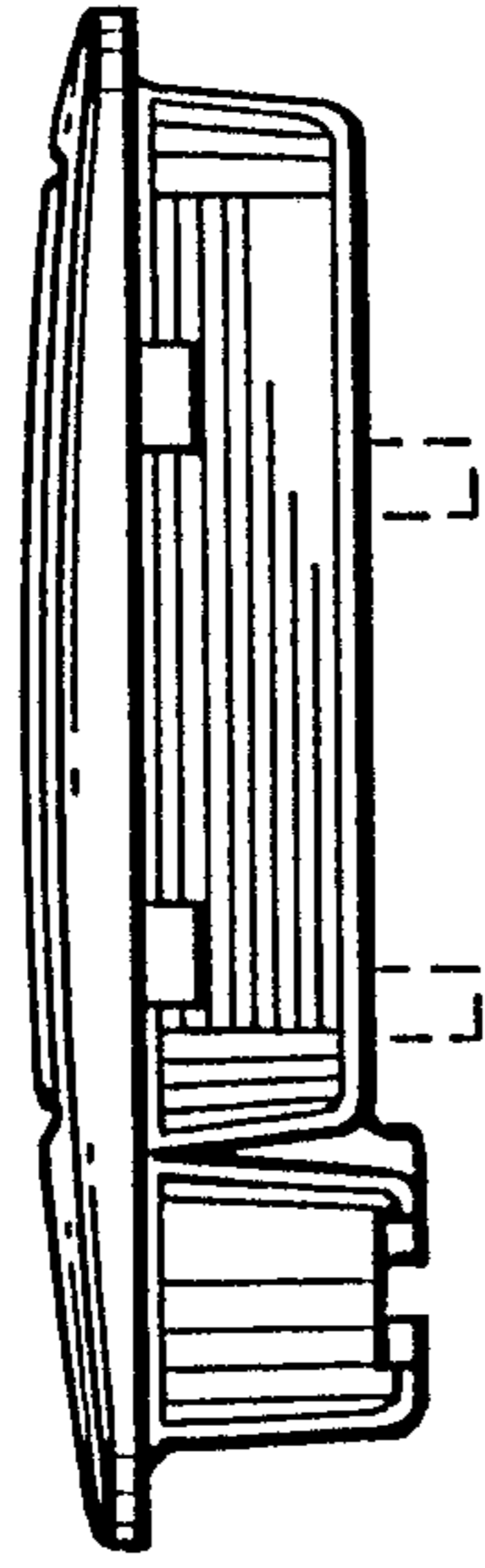

FIG. 19

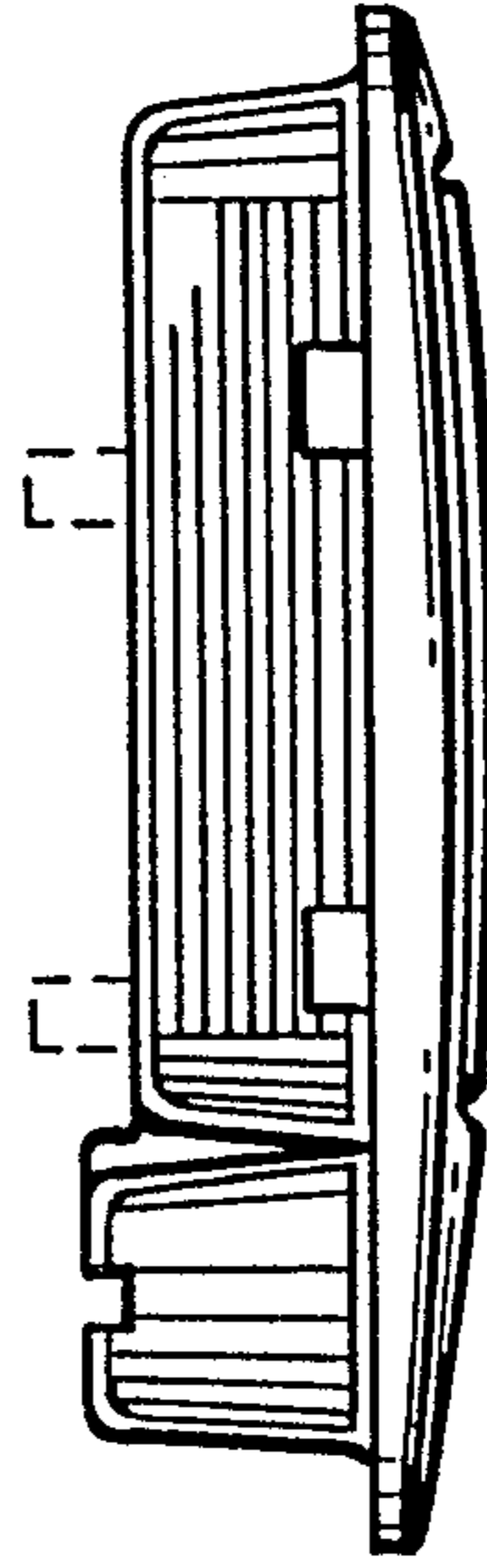

FIG. 20

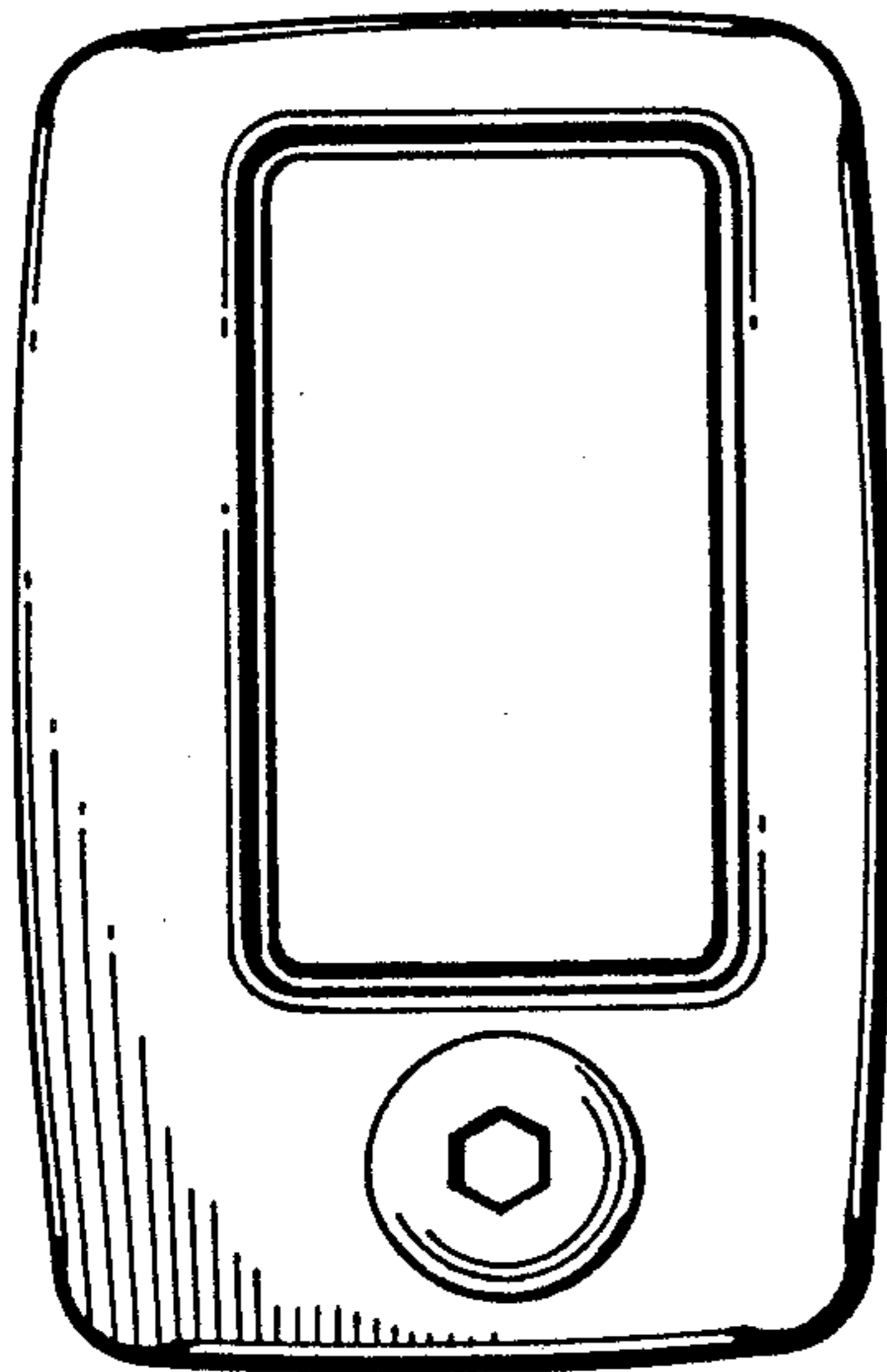

FIG. 21

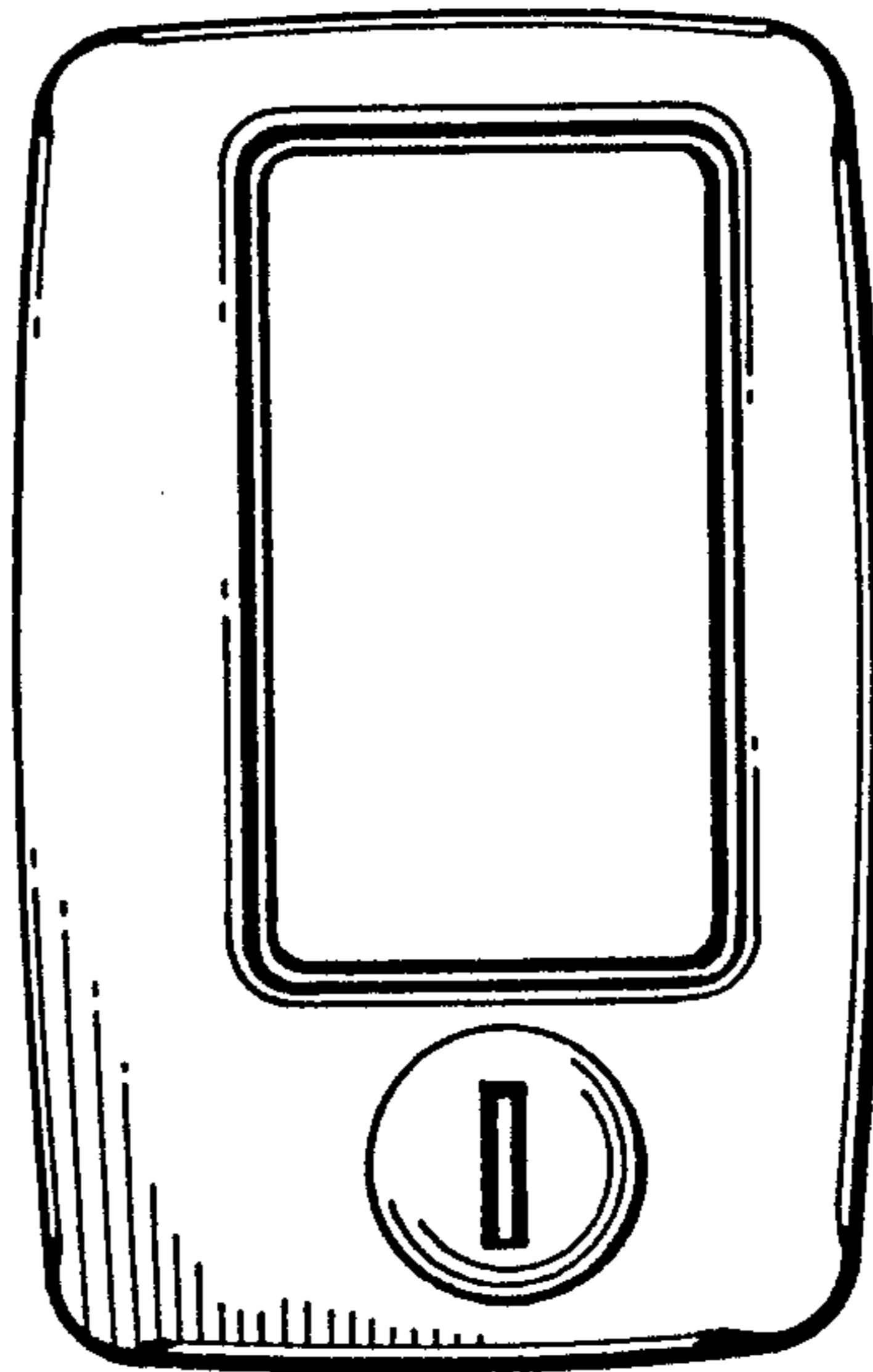

FIG. 22

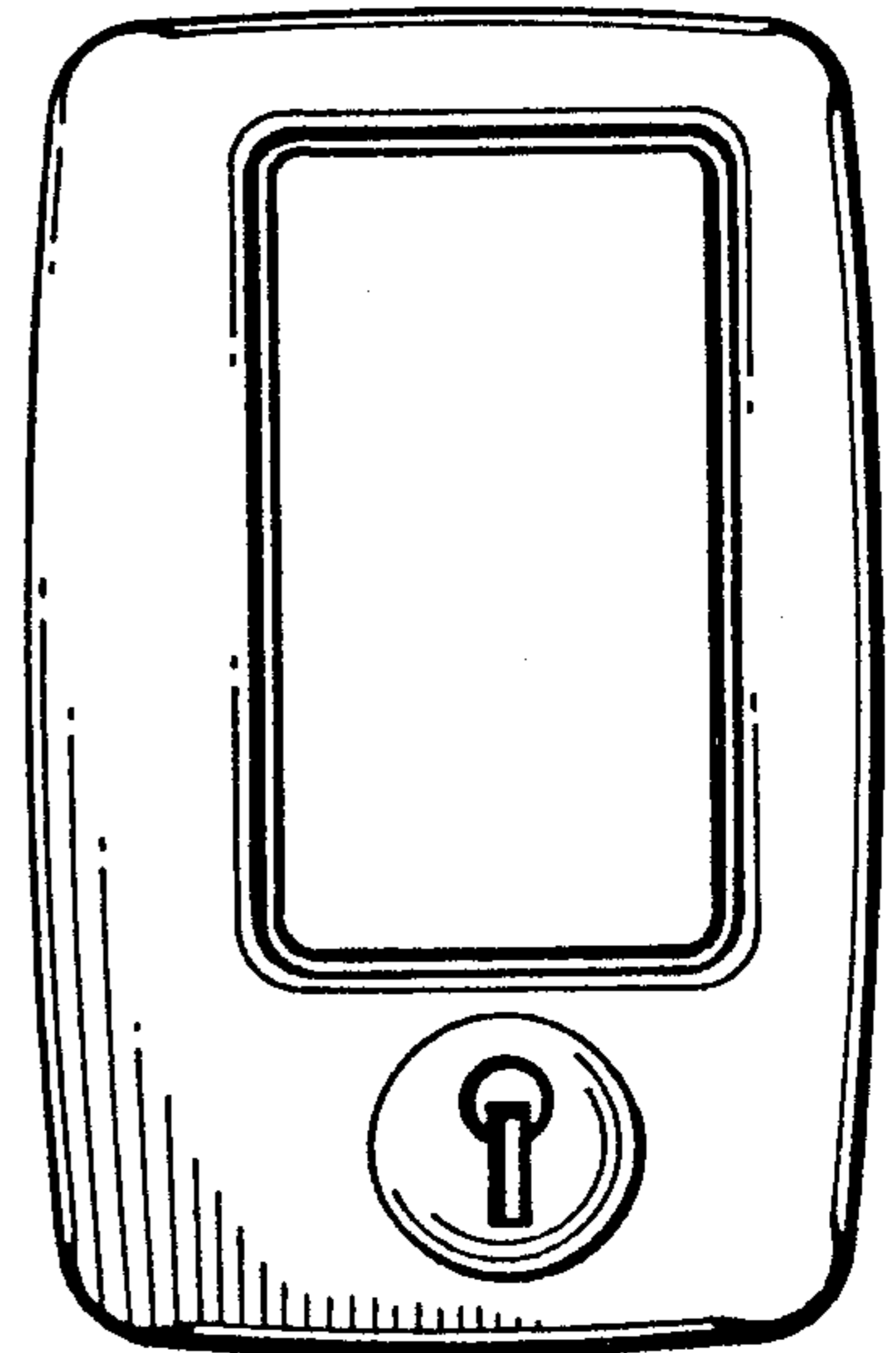

FIG. 23

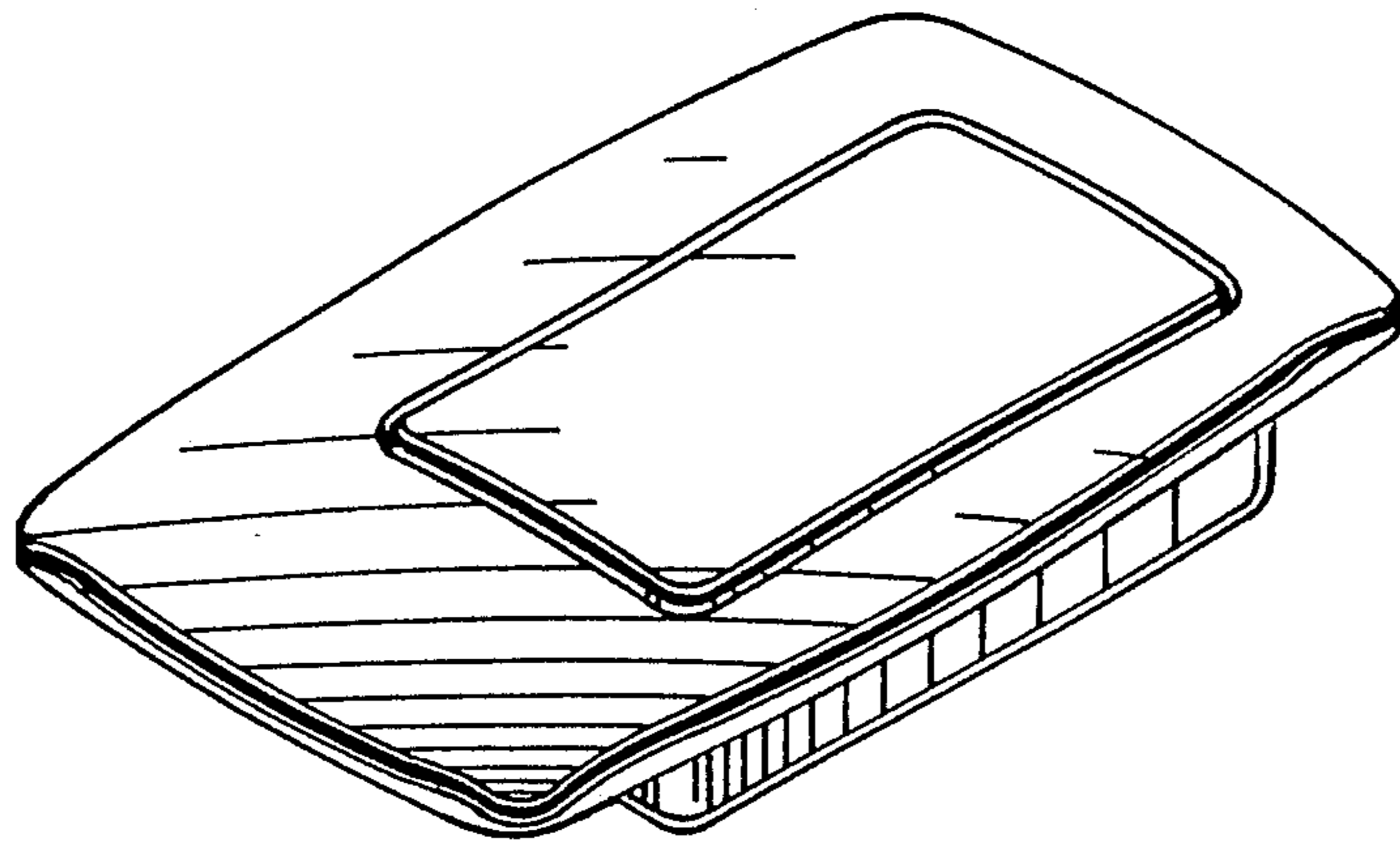

FIG. 24

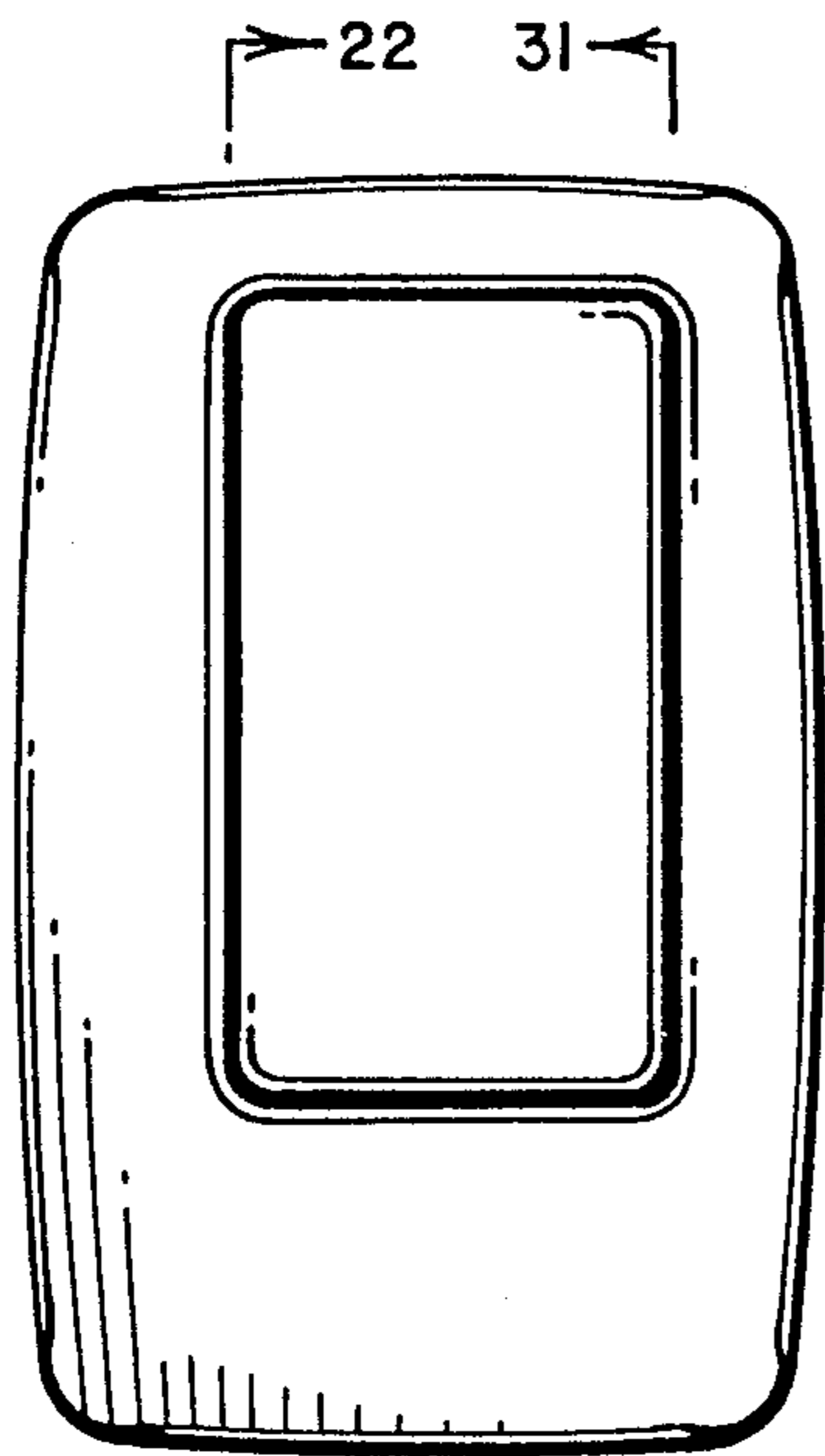

FIG. 25

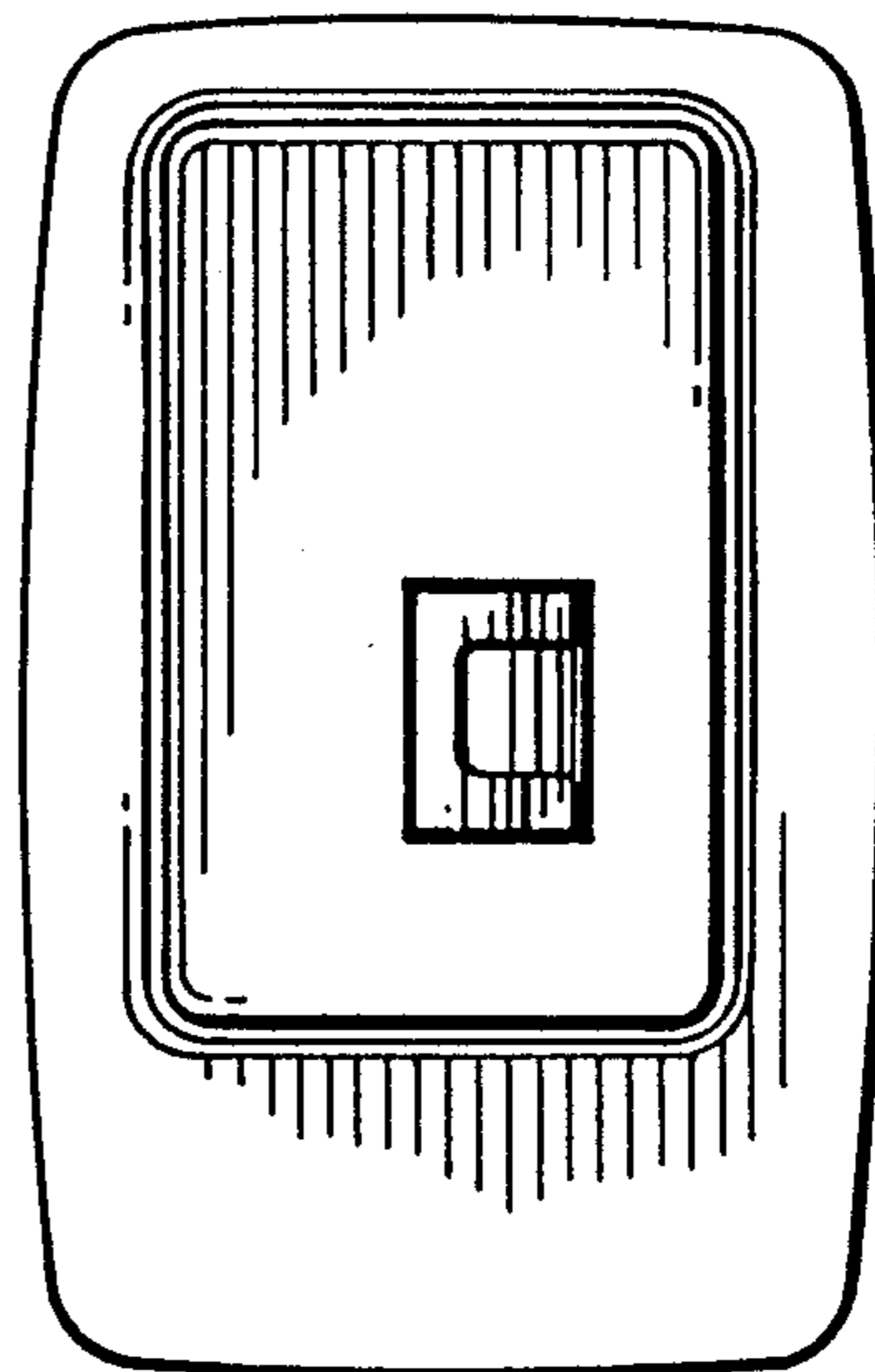

FIG. 26

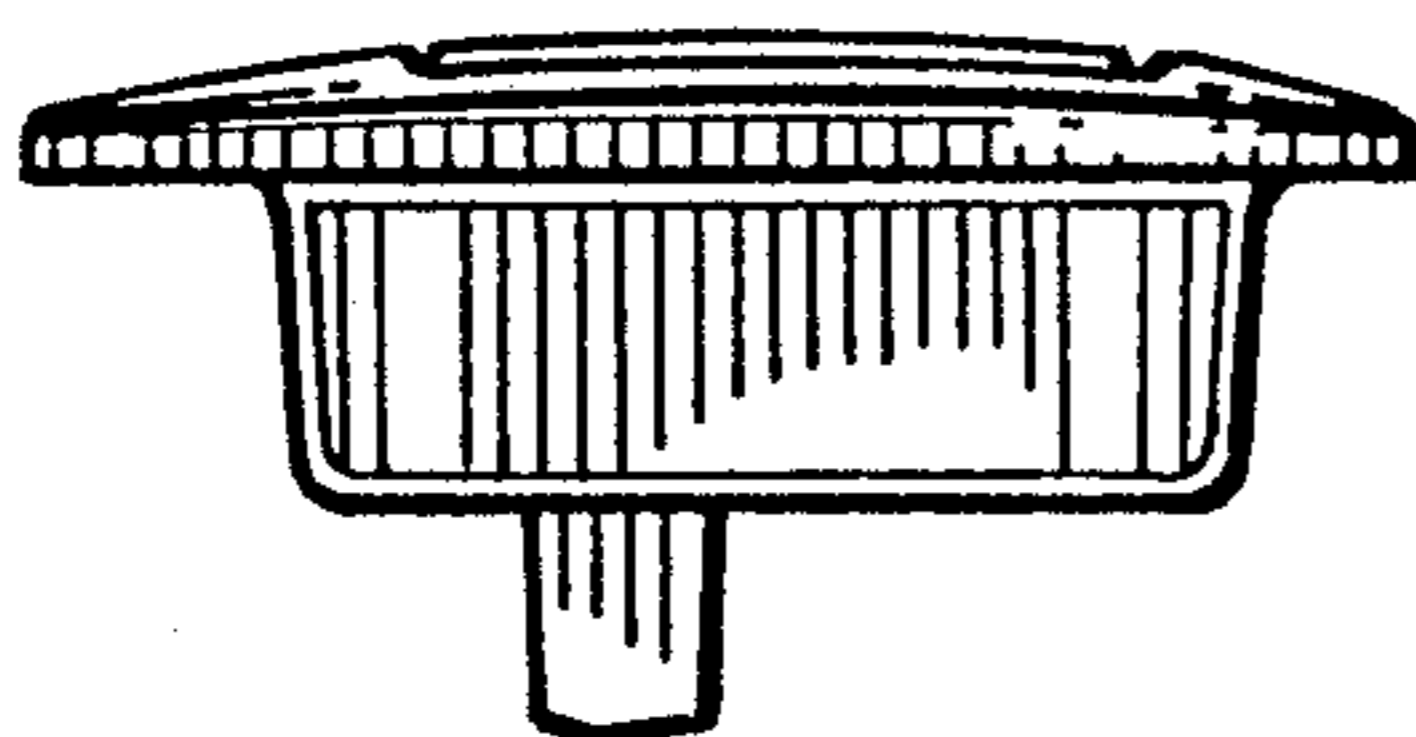

FIG. 27

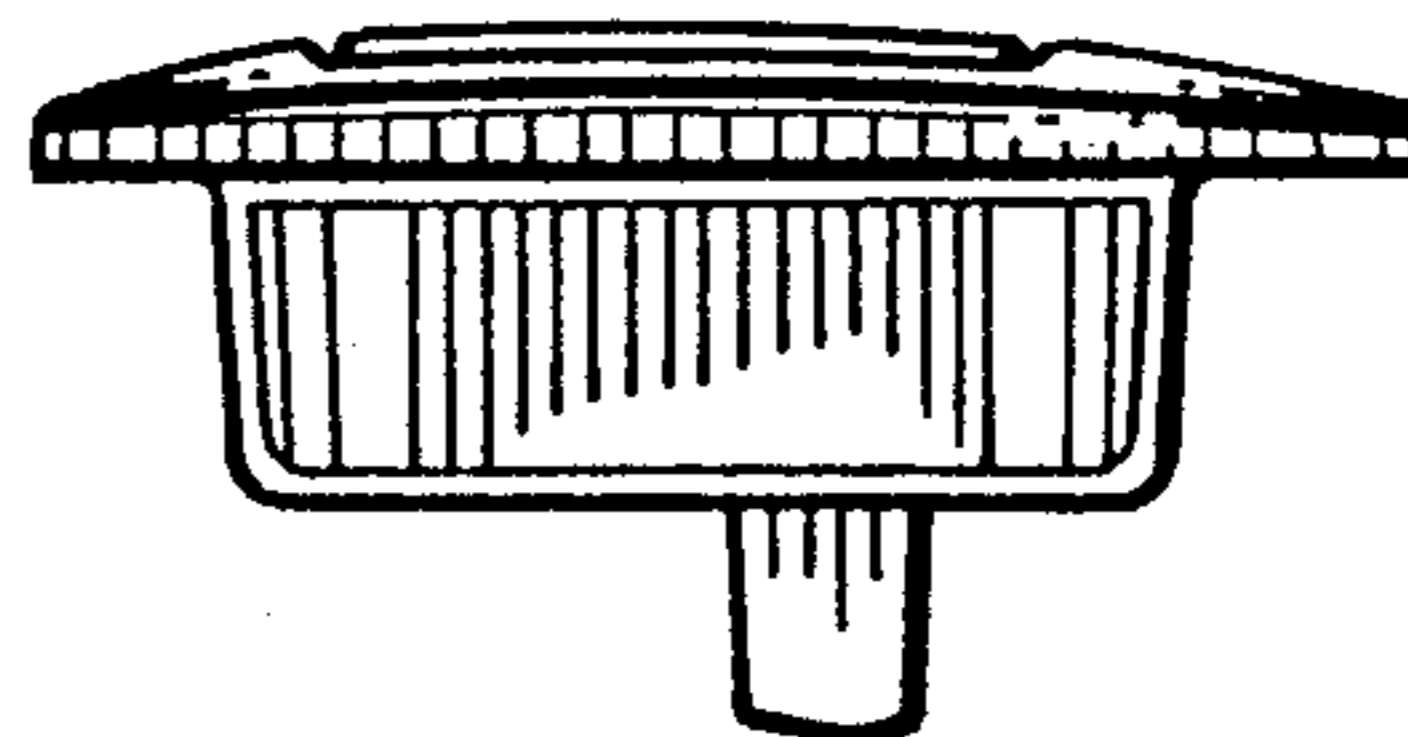

FIG. 28

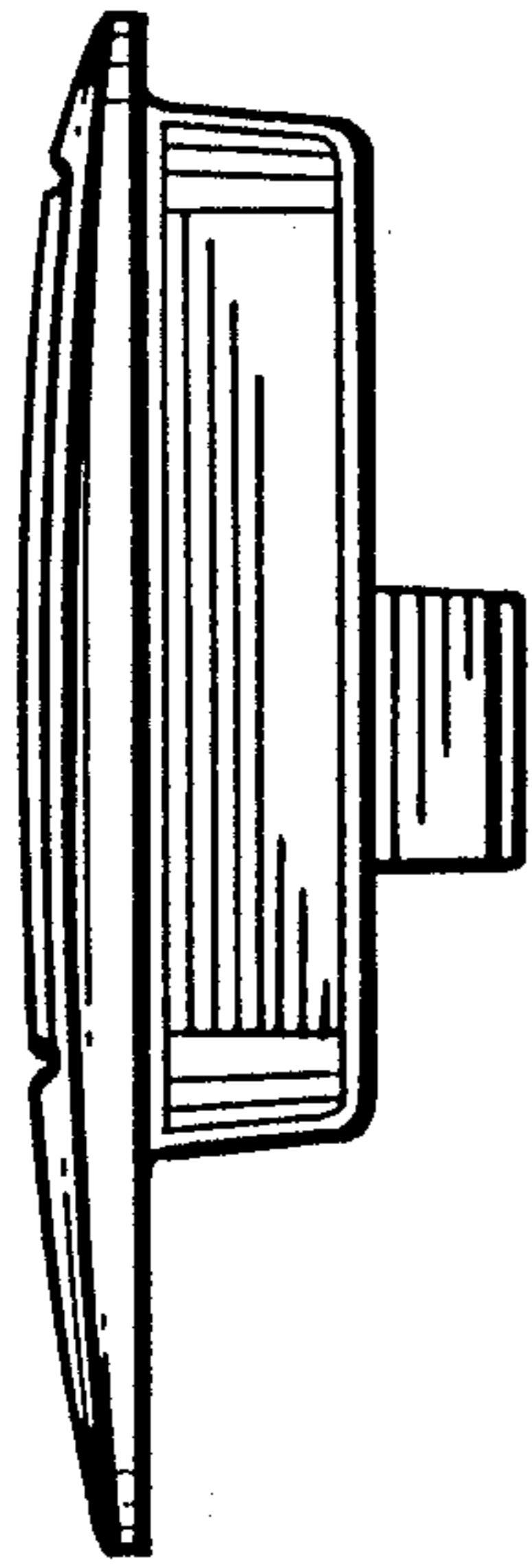

FIG. 29

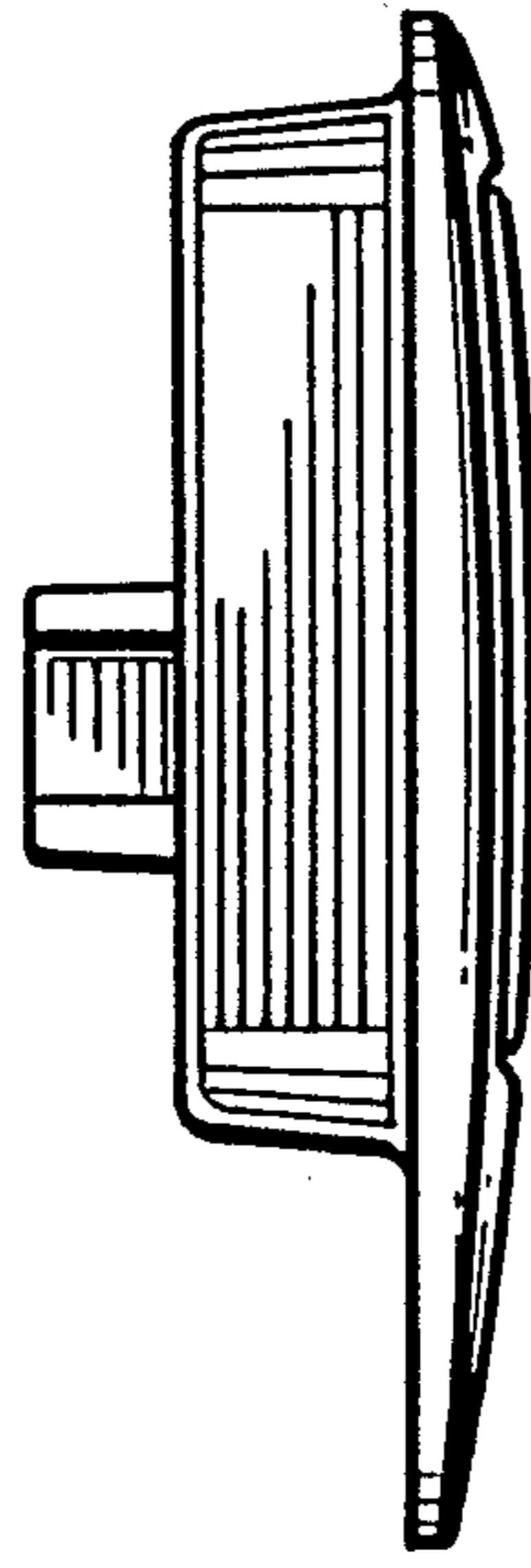

FIG. 30

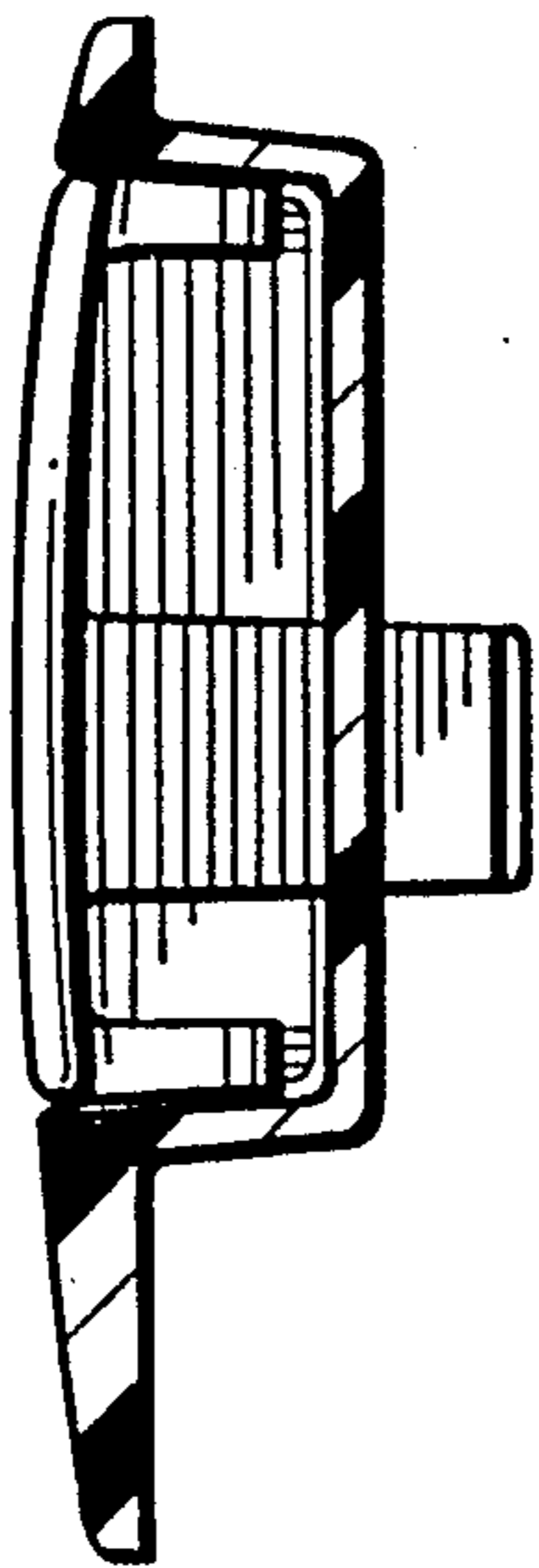

FIG. 31

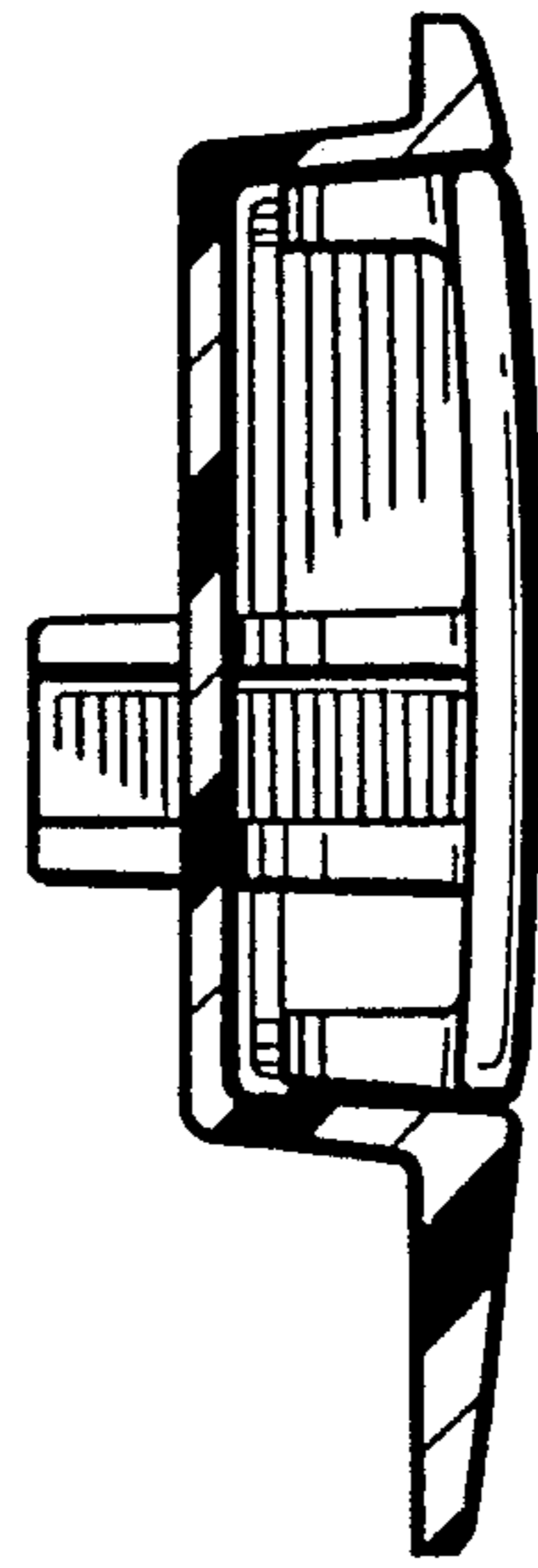

FIG. 32

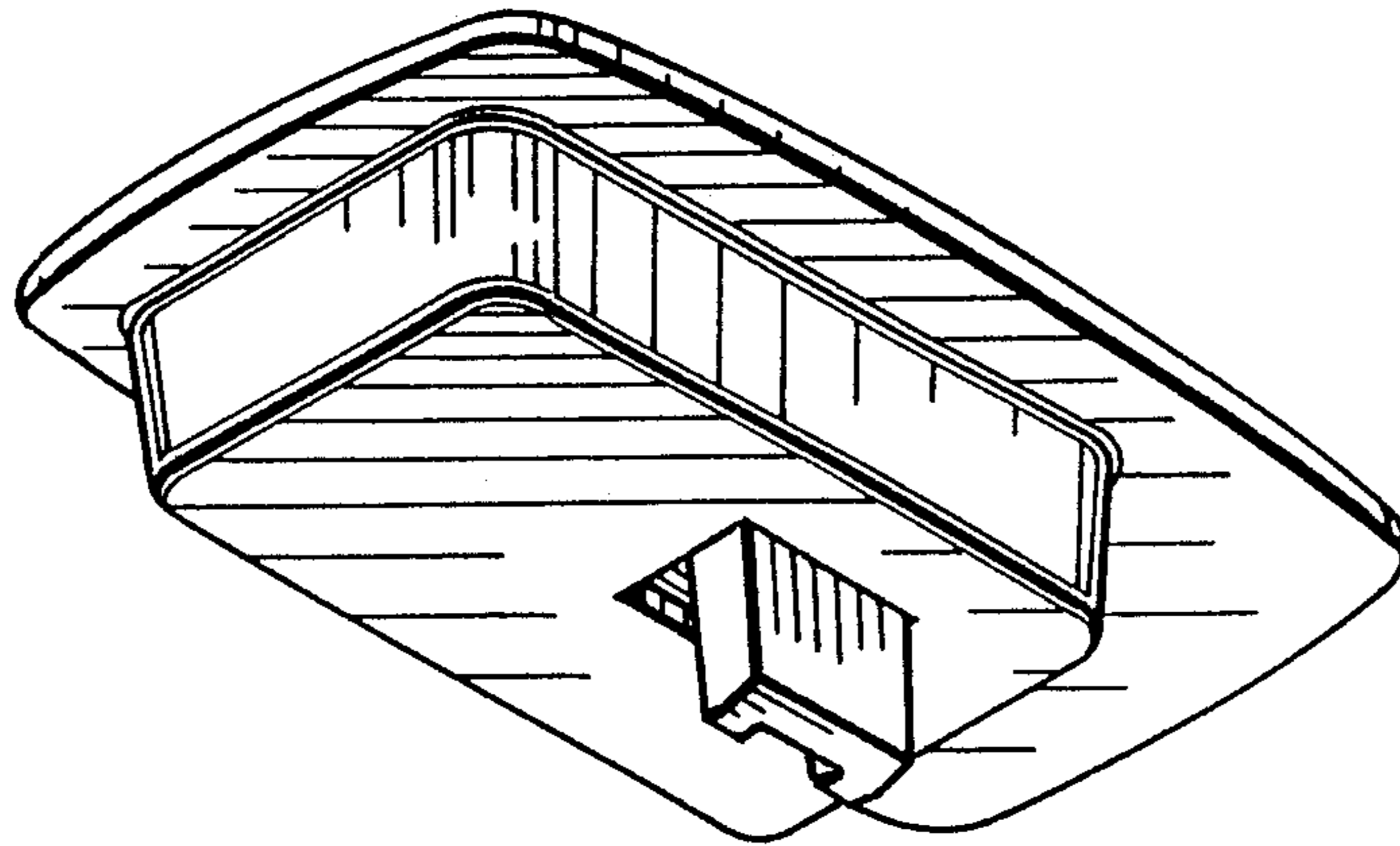

FIG. 33

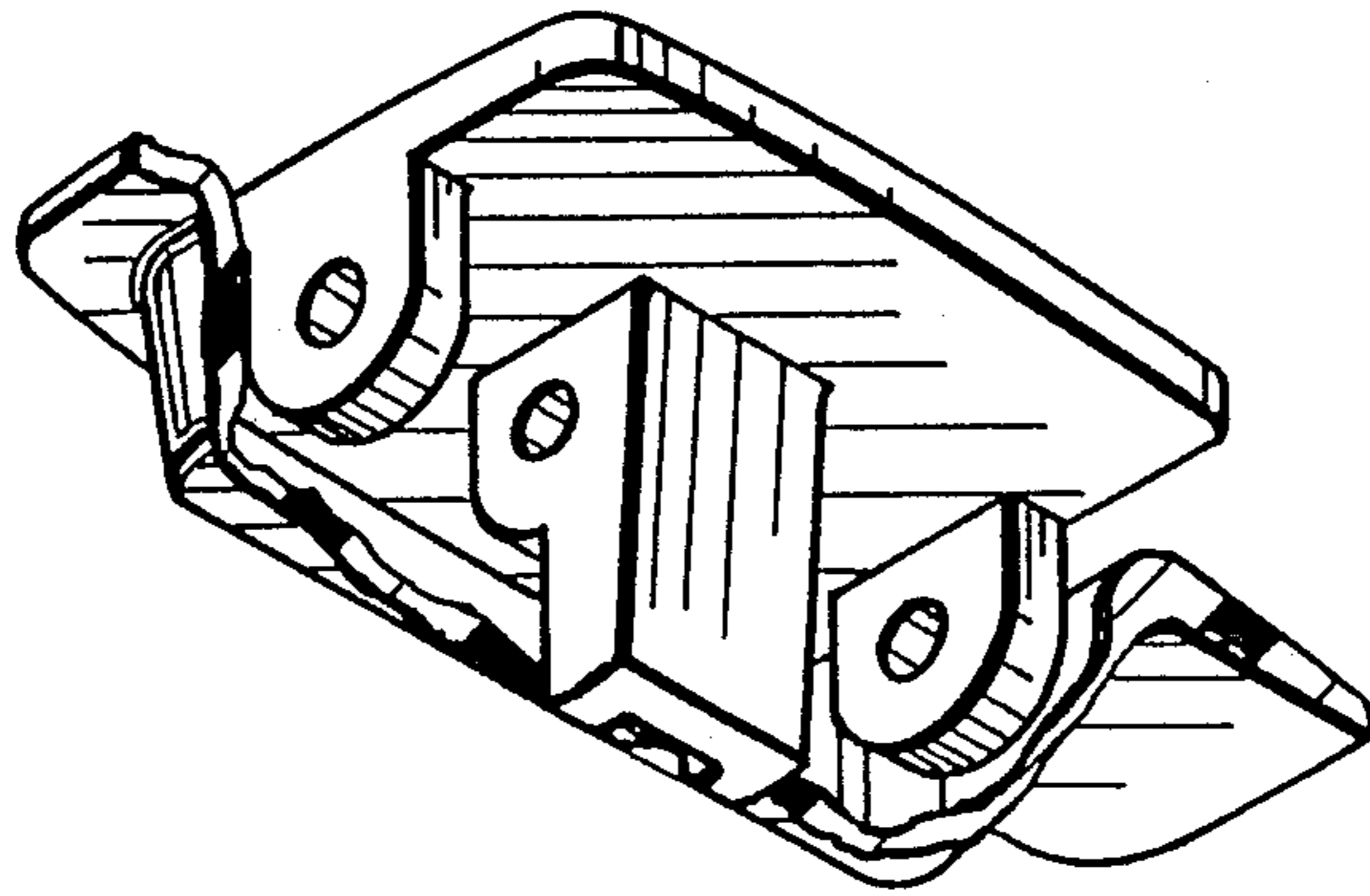

FIG. 34

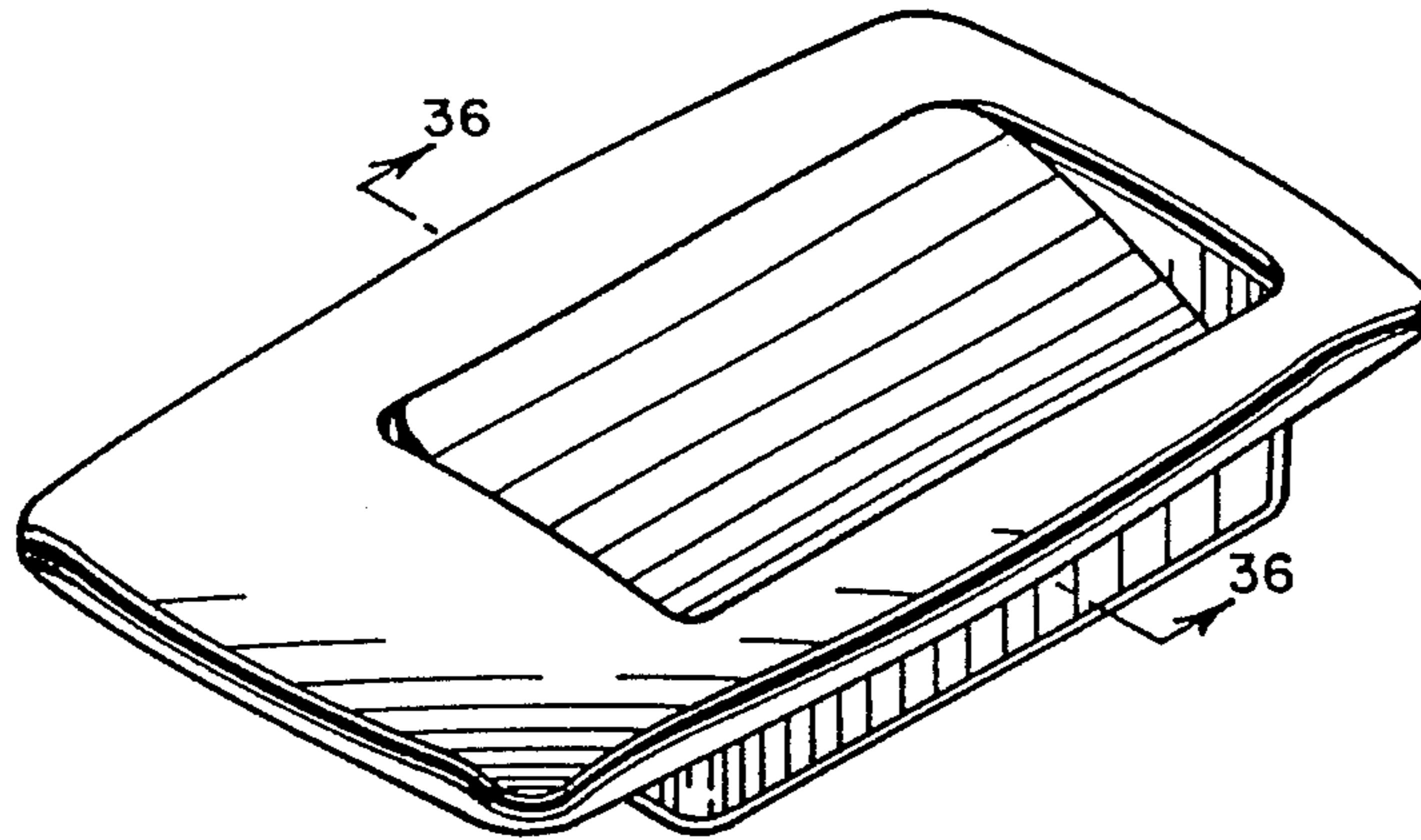

FIG. 35

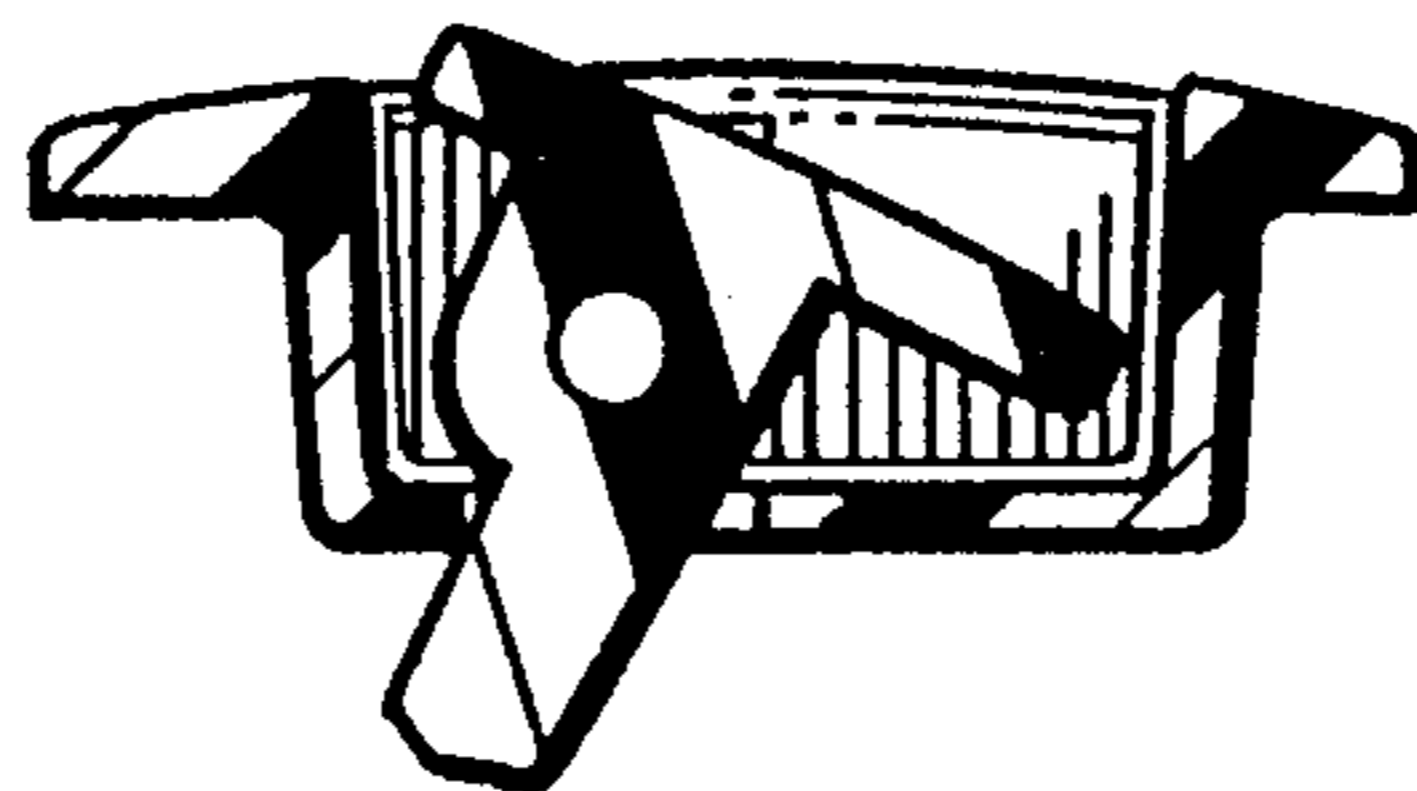

FIG. 36

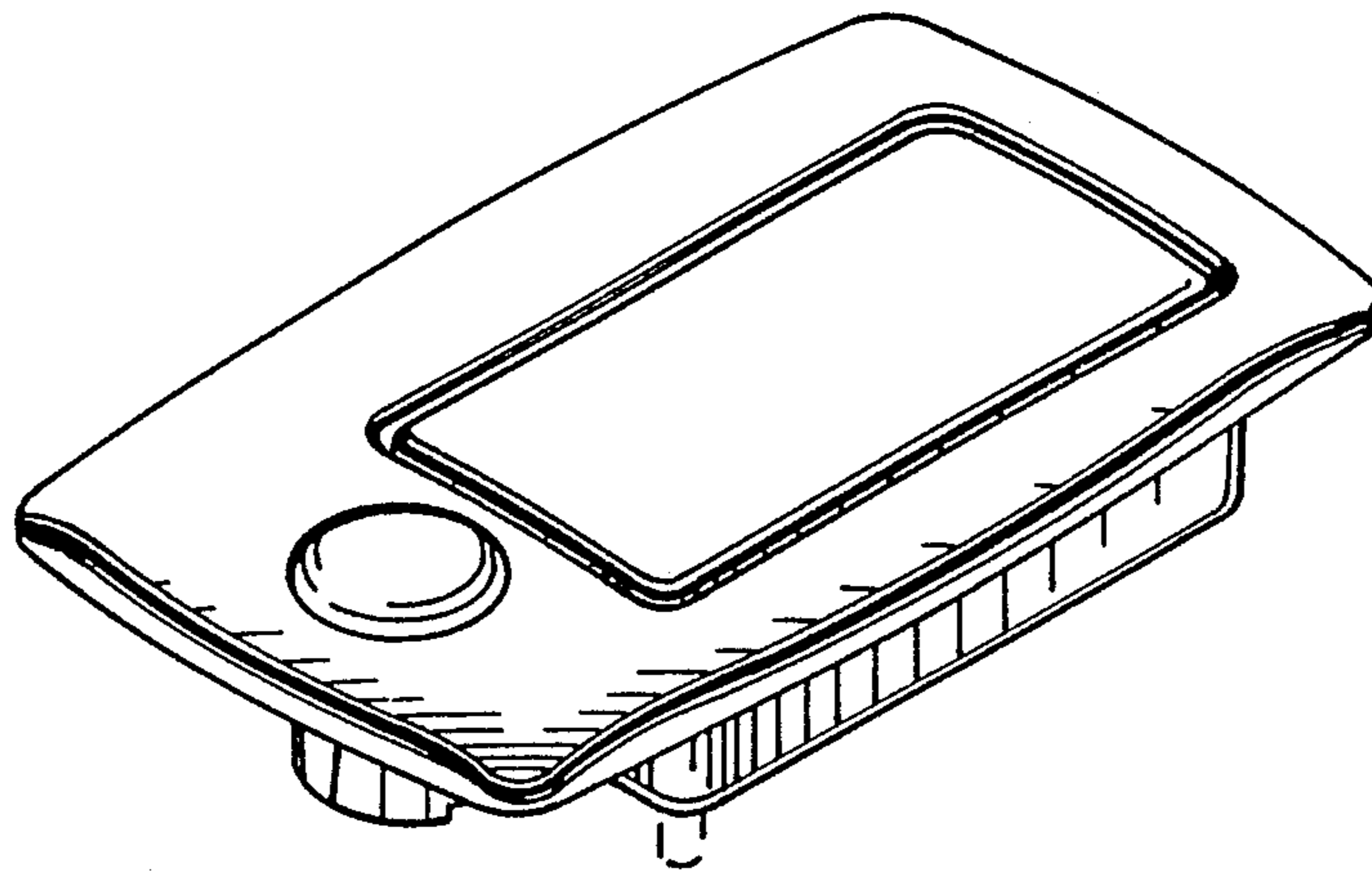

FIG. 37

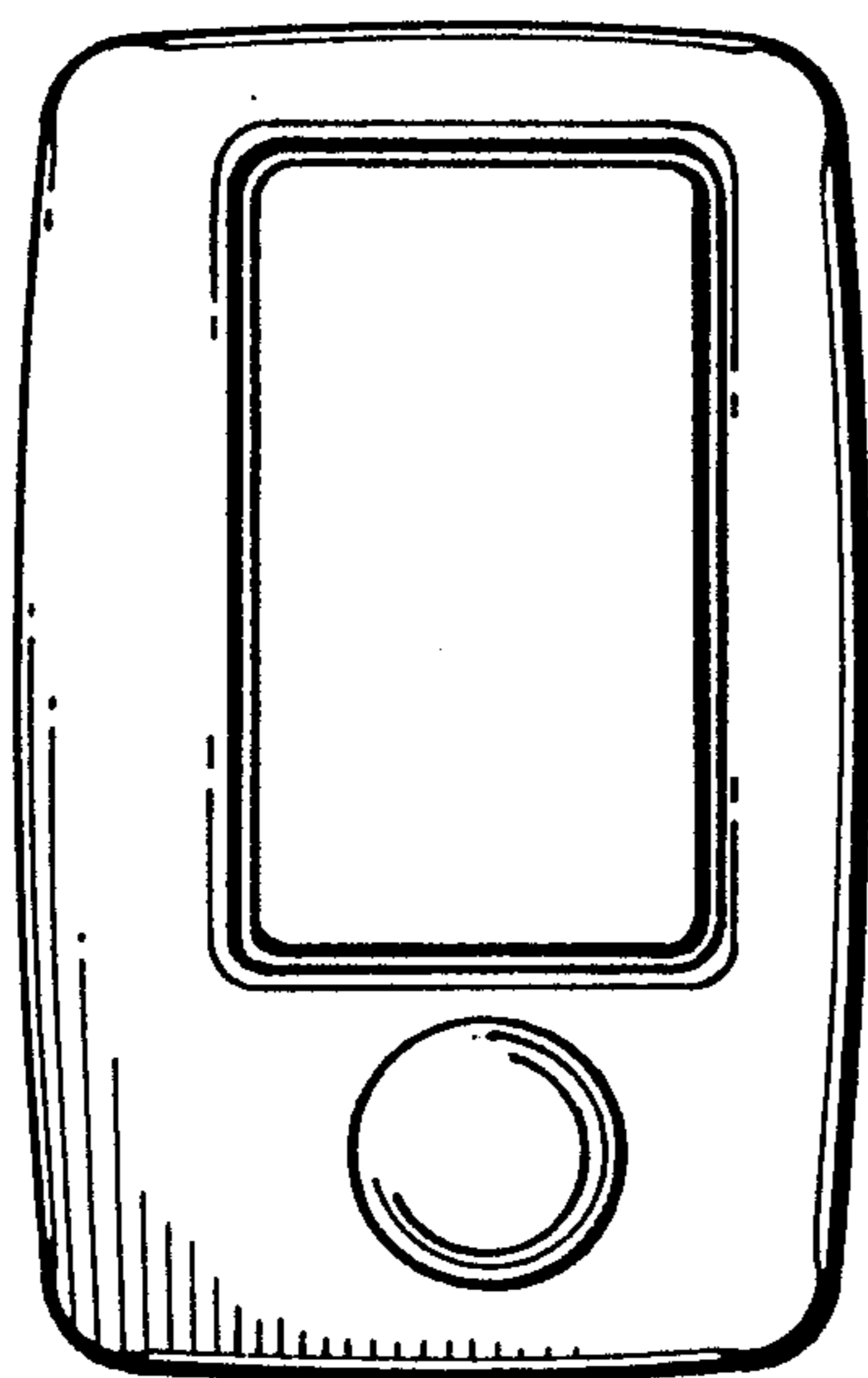

FIG. 38

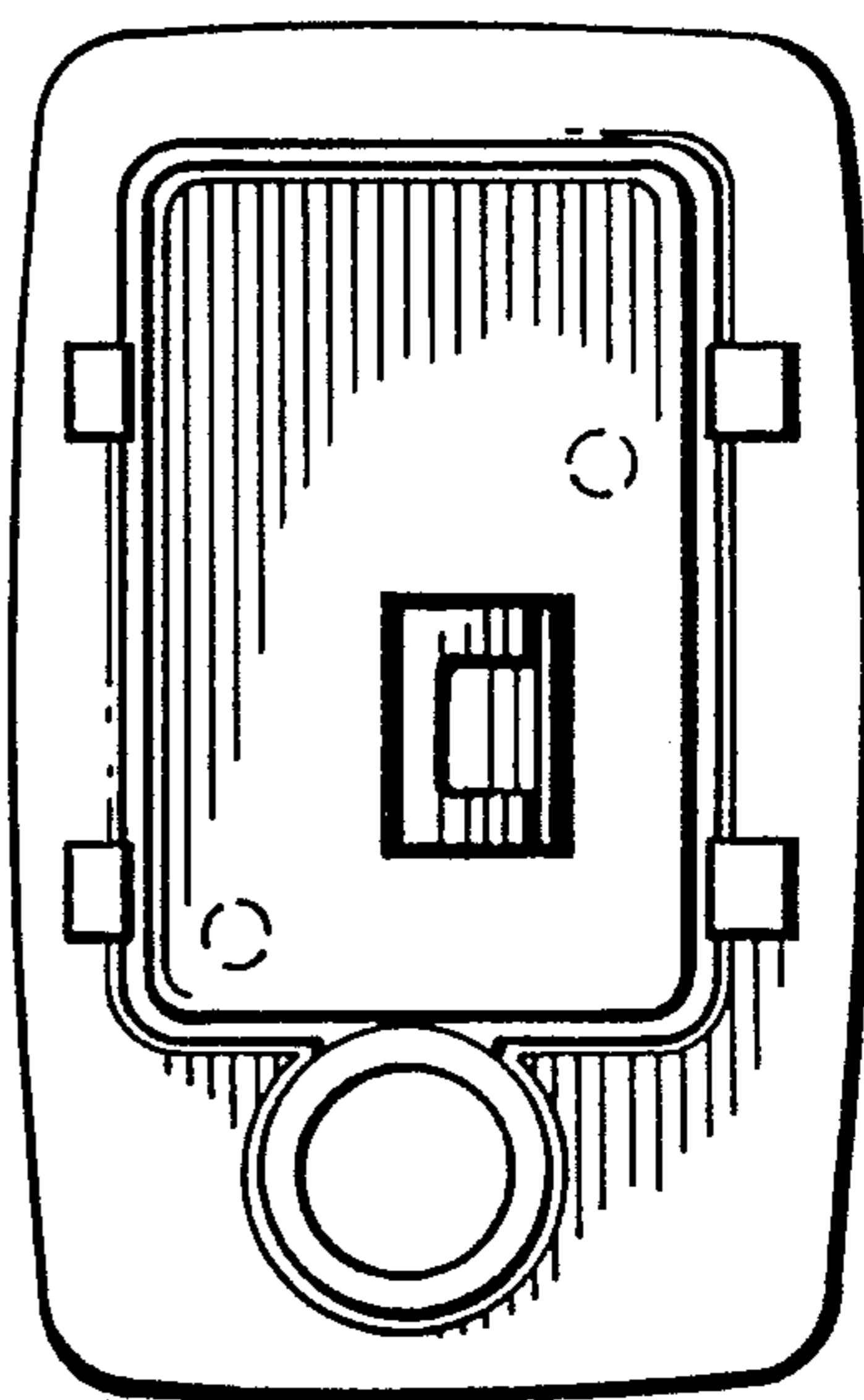

FIG. 39

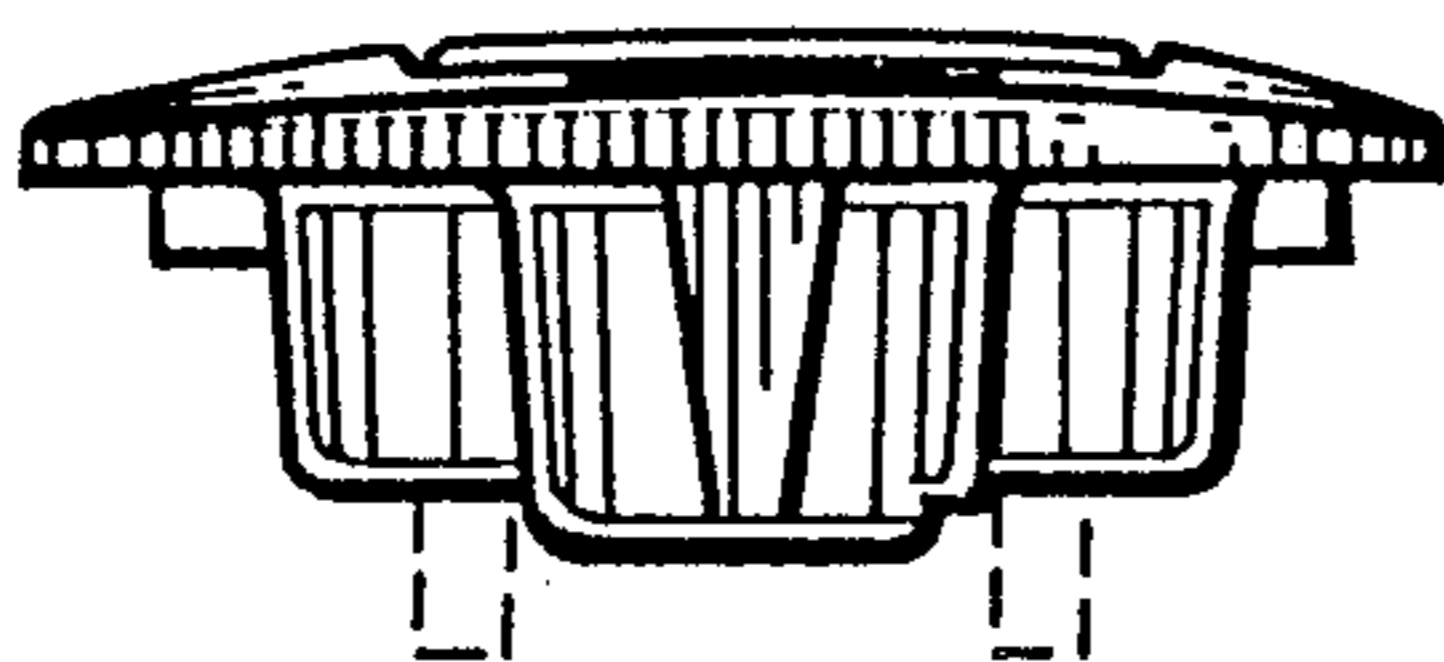

FIG. 40

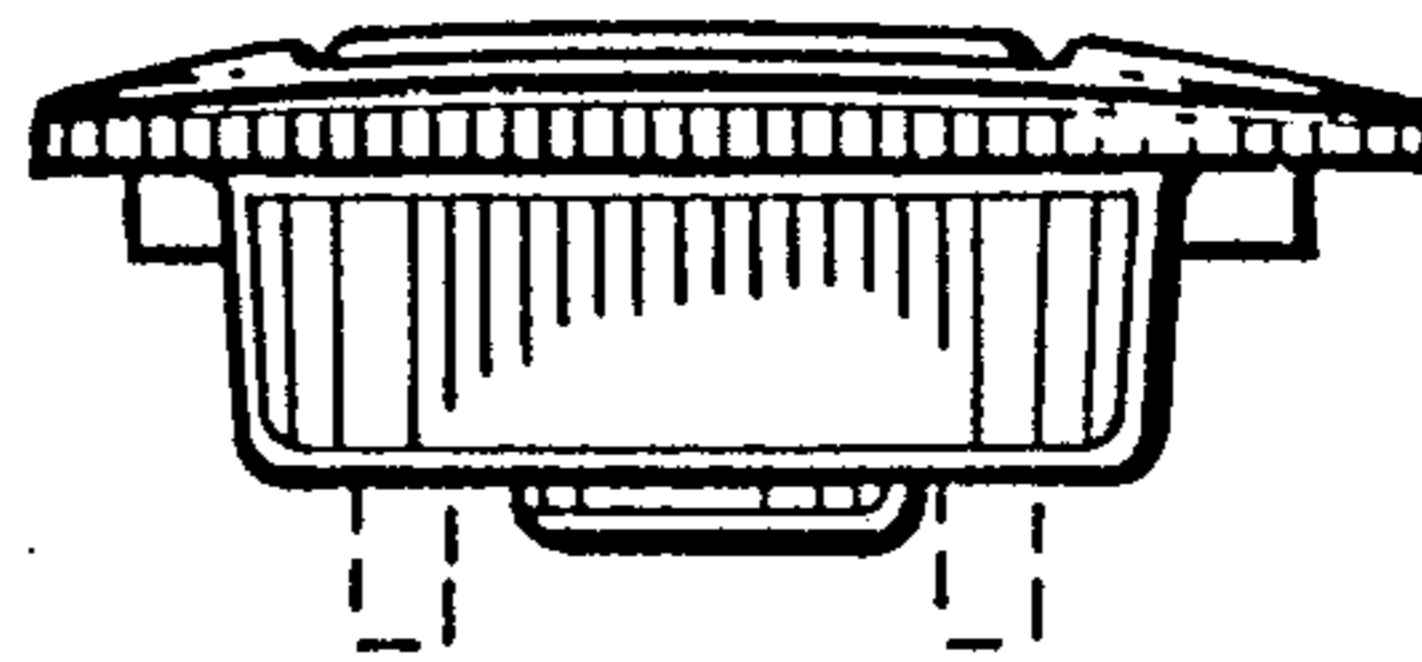

FIG. 41

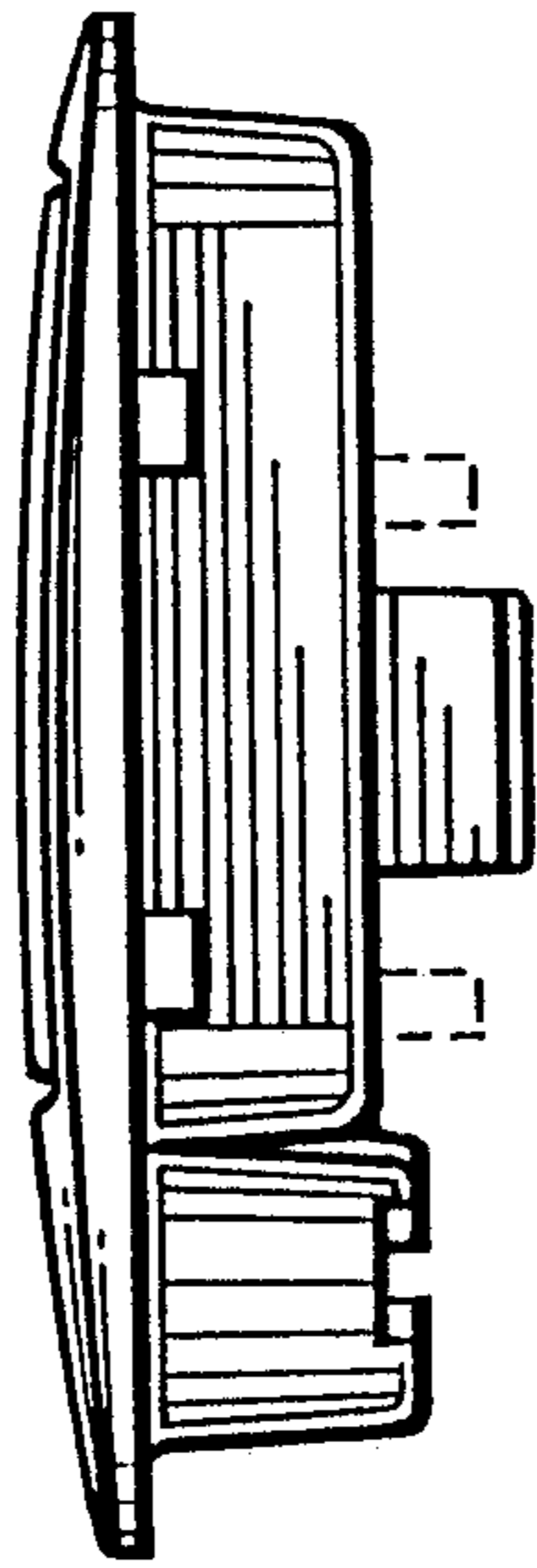

FIG. 42

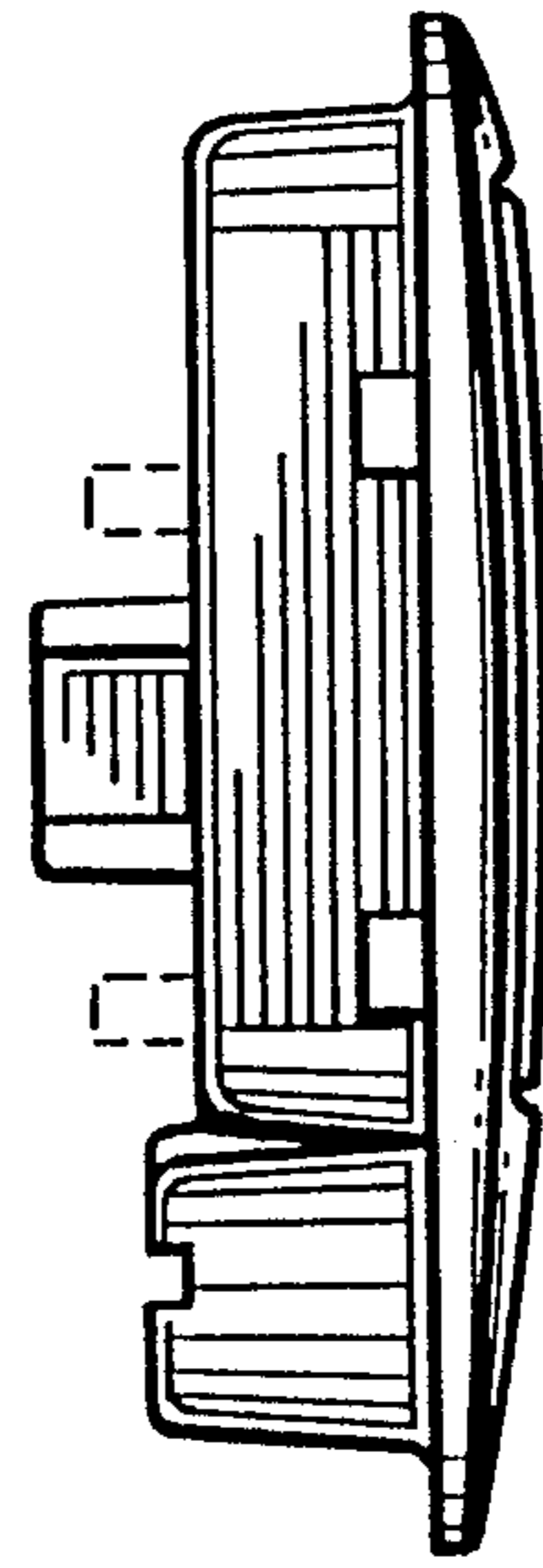

FIG. 43

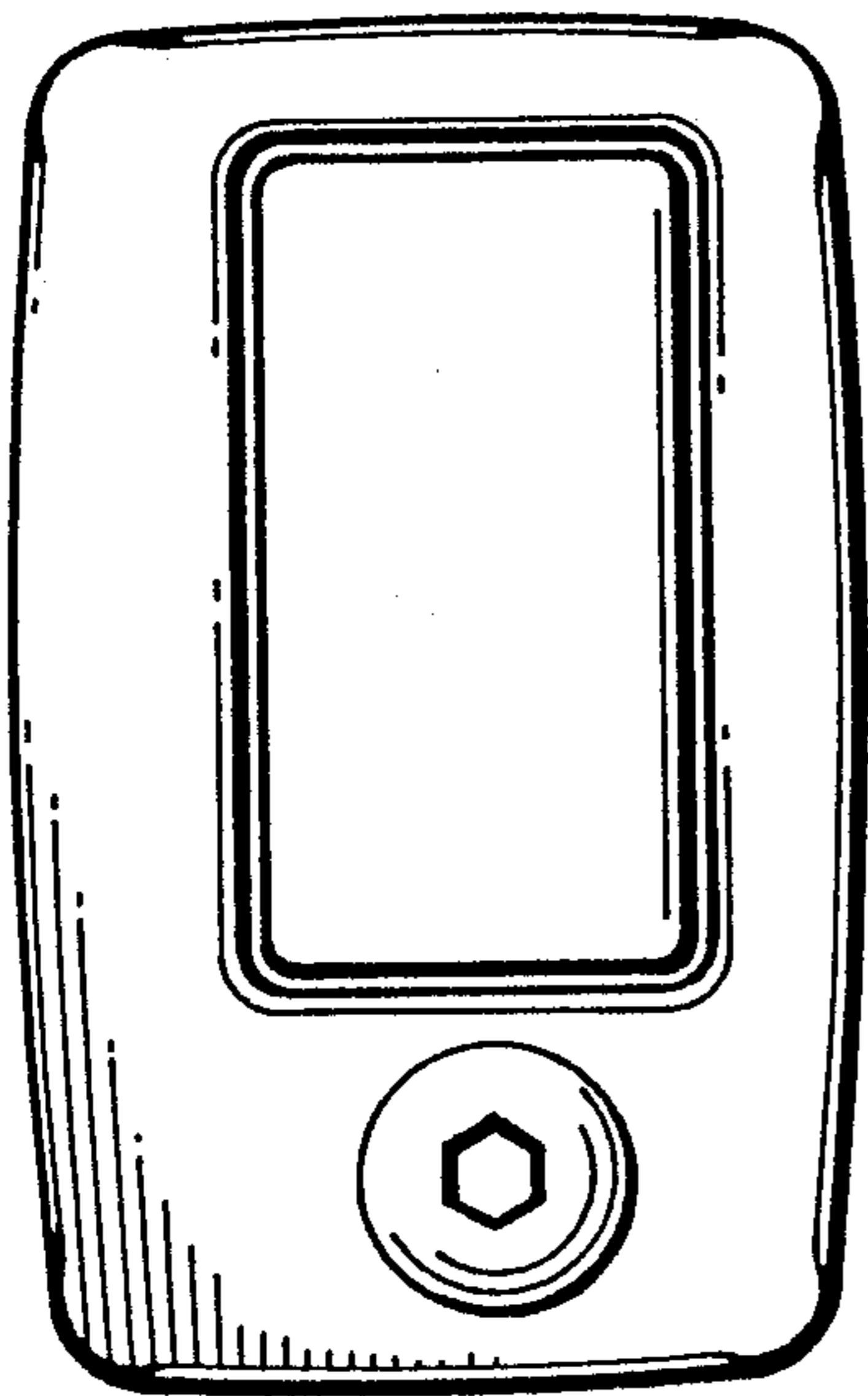

FIG. 44

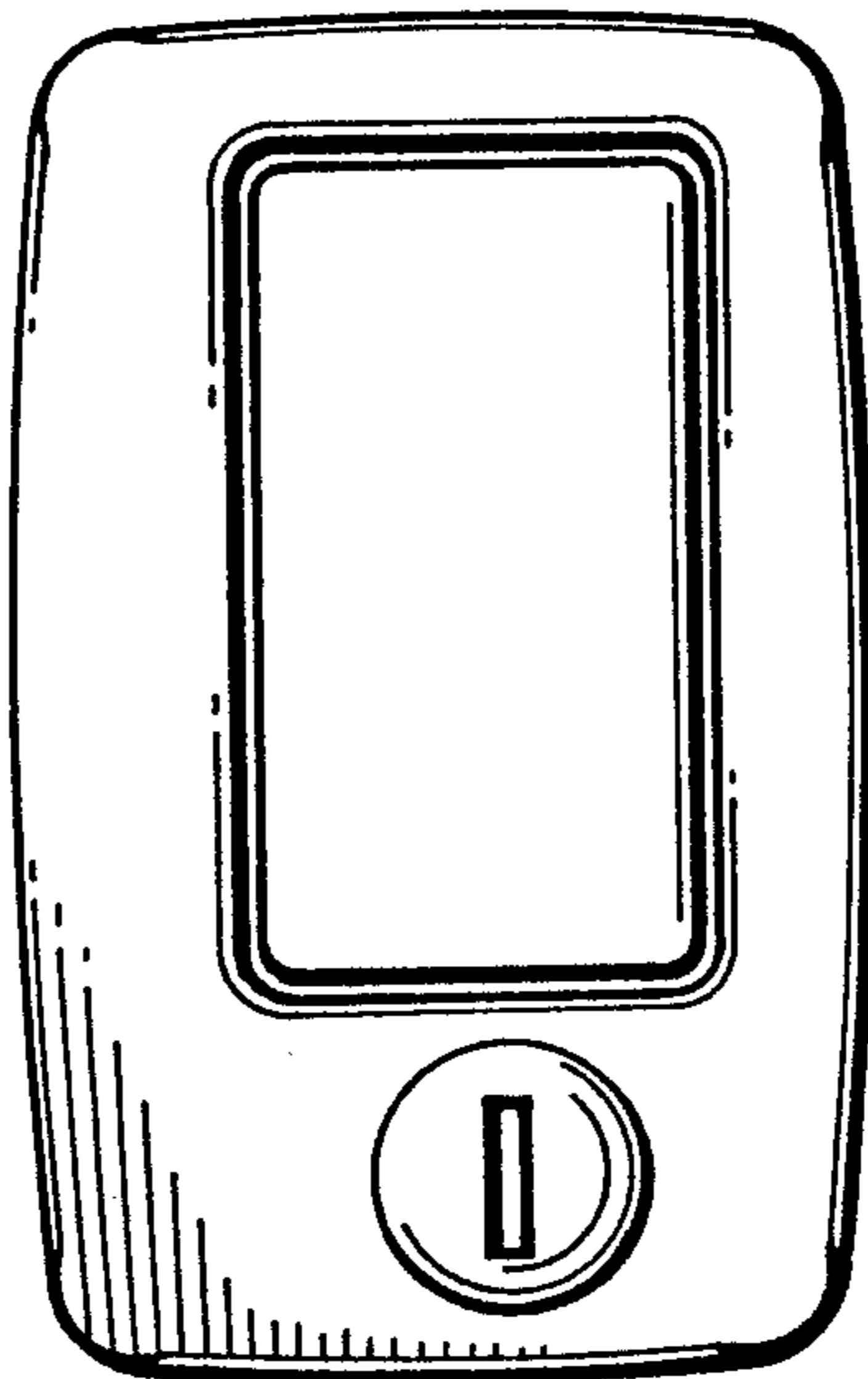

FIG. 45

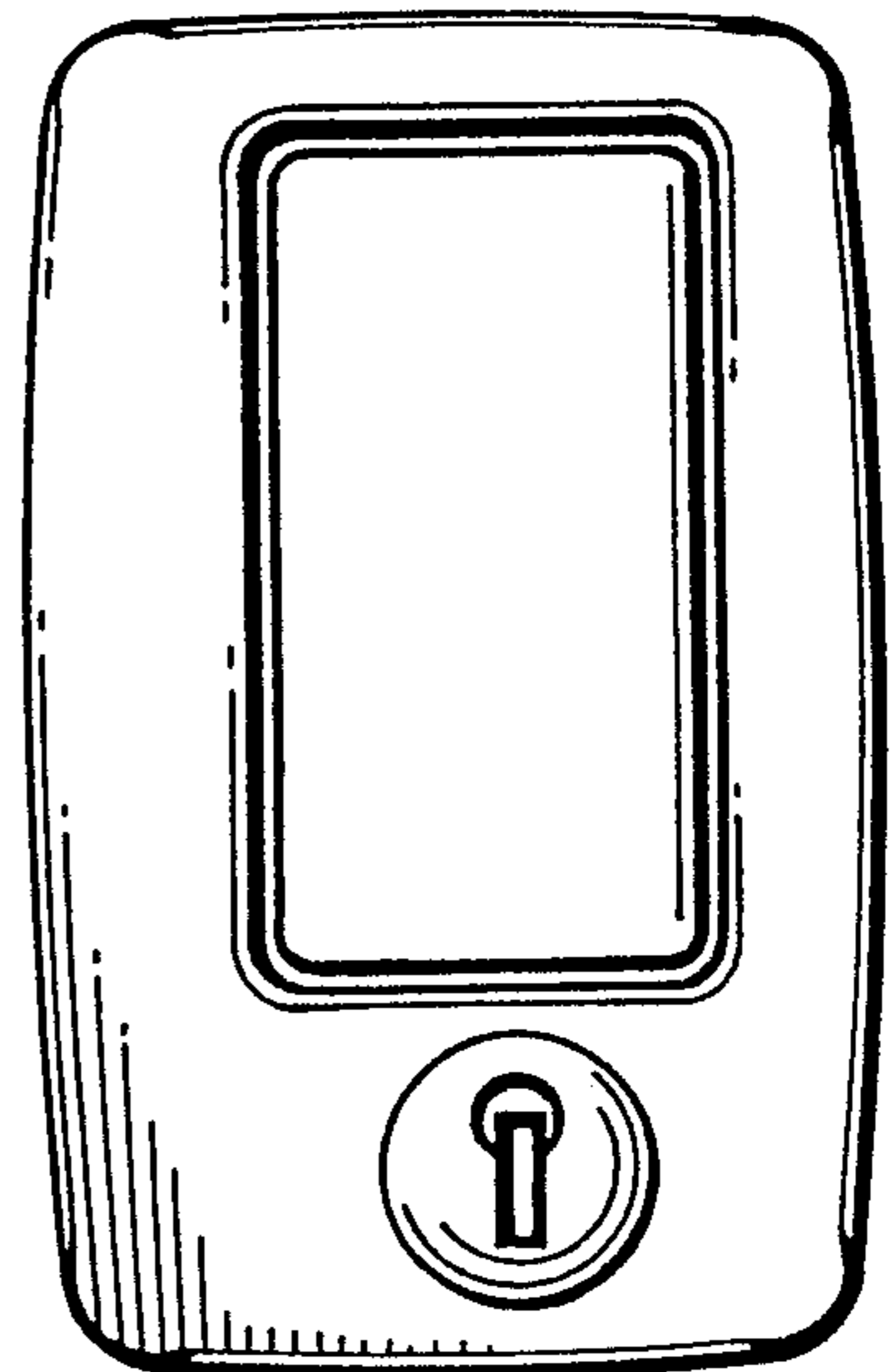

FIG. 46