

[54] COLLAPSIBLE EASEL OR SIMILAR ARTICLE

[76] Inventor: Gregory N. Glebe, 1211 Locust Street, Philadelphia, Pa. 19107

[**] Term: 14 Years

[21] Appl. No.: 940,811

[22] Filed: Dec. 11, 1986

[52] U.S. Cl. D6/310; D6/419

[58] Field of Search D6/300, 310, 313, 419; 248/441.1, 450, 460, 462, 463, 464

[56] References Cited

U.S. PATENT DOCUMENTS

- D. 242,757 12/1976 Stark .
- D. 260,491 9/1981 Maclin .
- D. 265,786 8/1982 Angell .
- D. 271,454 11/1983 Forte .
- 3,799,488 3/1974 Sena .

OTHER PUBLICATIONS

Beckley-Cardy (Mid-Atlantic Region) copyright 1985, three pages.
 Chaselle Arts & Crafts of Columbia, Md., six pages, (prior to 12/11/86).
 Kurtz Bros. of Clearfield, Pa., copyright 1985, three pages.
 "Studio Easels" five pages.
 No. 12, "Woodstock Easel"-three pages.

Primary Examiner—B. J. Bullock
 Attorney, Agent, or Firm—Charles H. Lindrooth

[57] CLAIM

The ornamental design for a collapsible easel or similar article, as shown and described.

DESCRIPTION

FIG. 1 is a perspective view of an easel showing my new design;
 FIG. 2 is an enlarged front elevational view thereof;
 FIG. 3 is an enlarged right side elevational view thereof;
 FIG. 4 is an enlarged rear elevational view thereof;
 FIG. 5 is an enlarged top plan view thereof;
 FIG. 6 is an enlarged bottom plan view thereof.

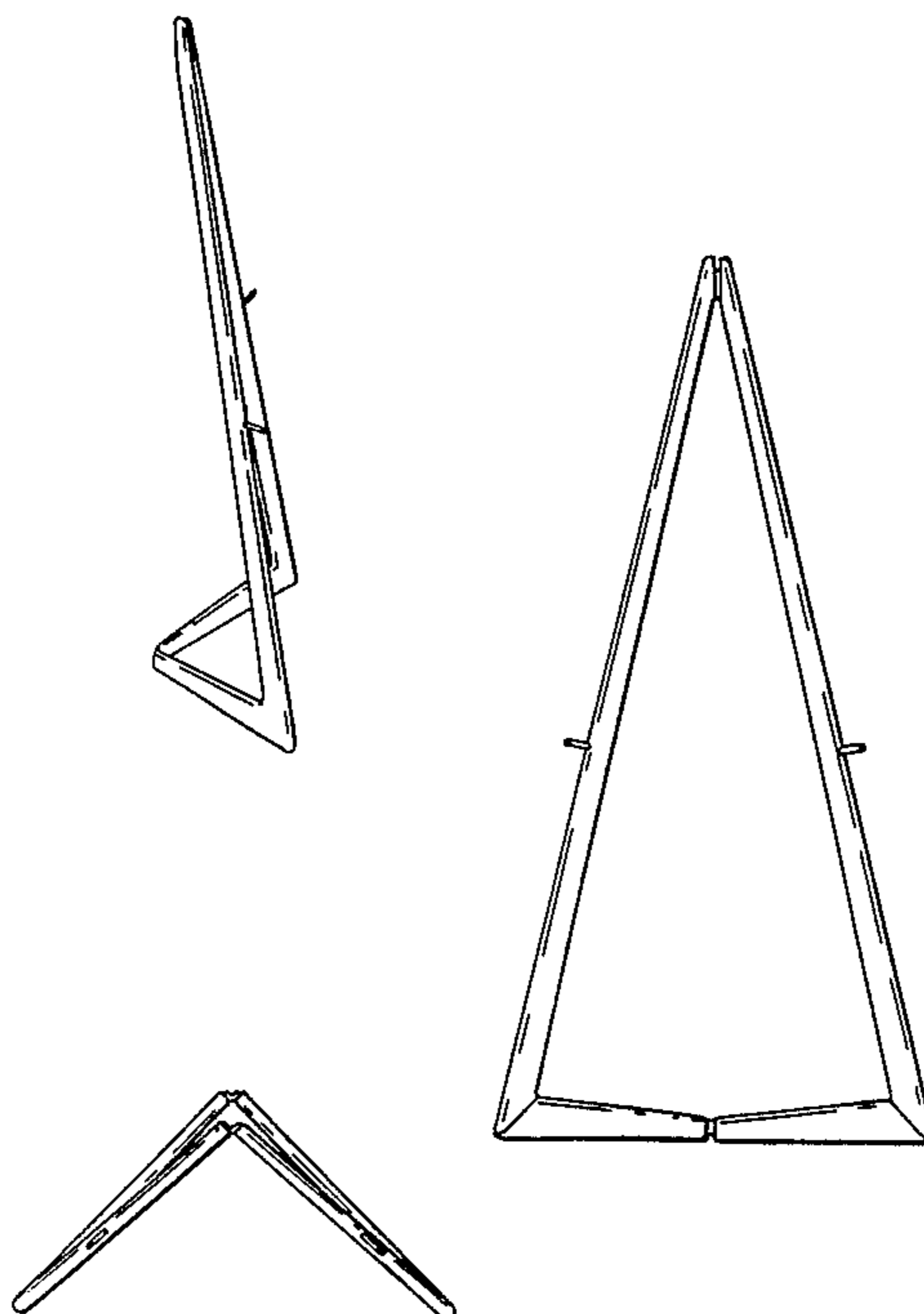

FIG. 1

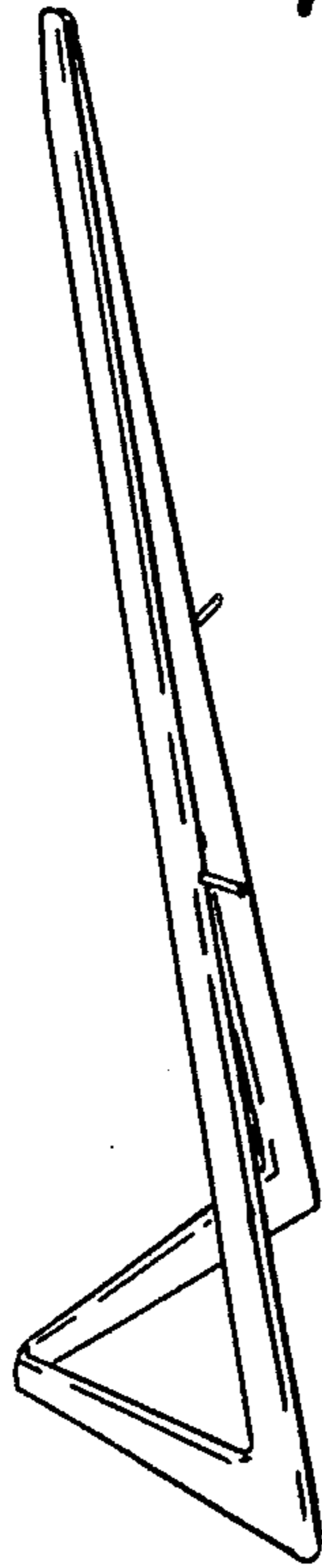

FIG. 2

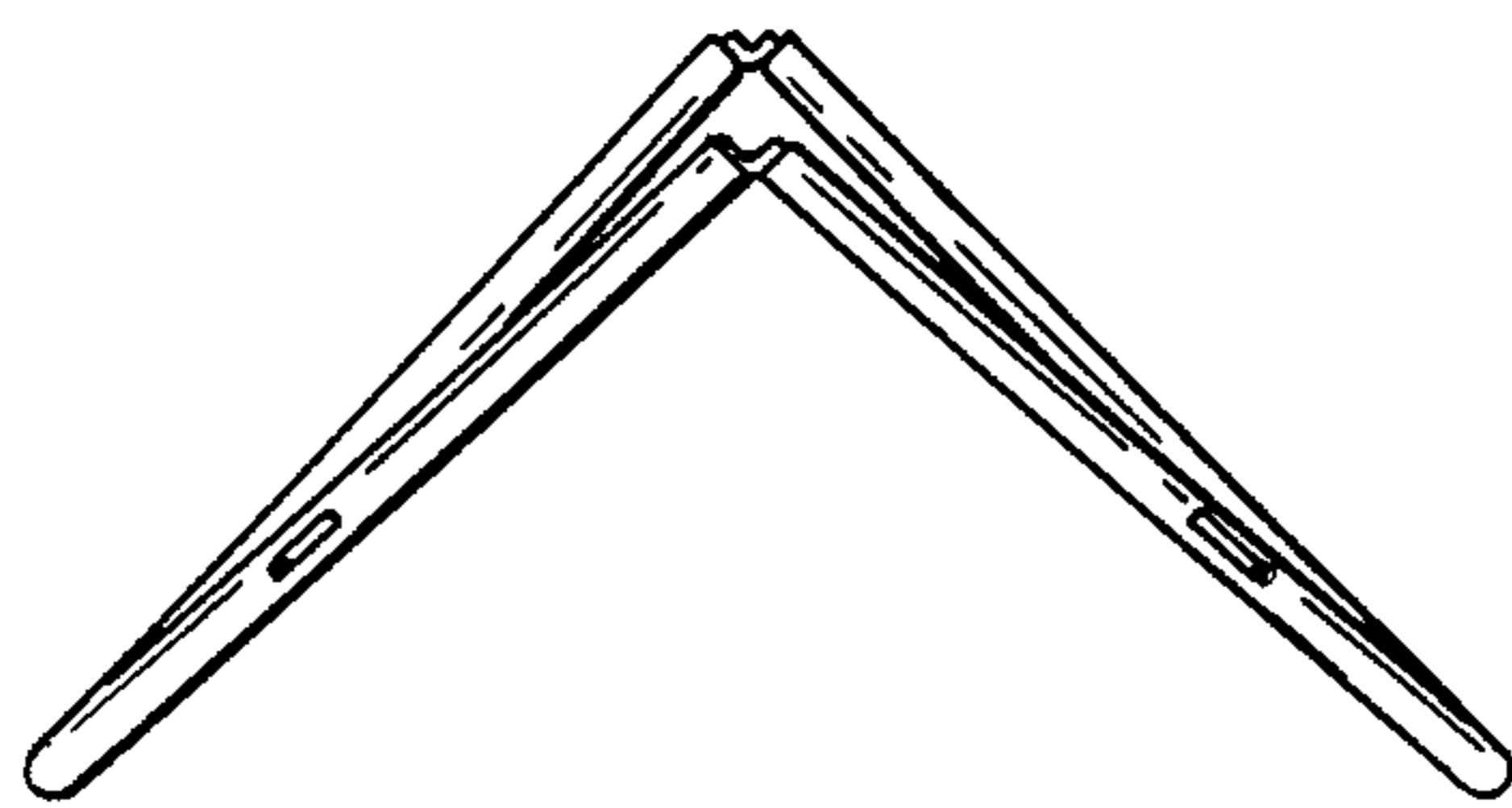
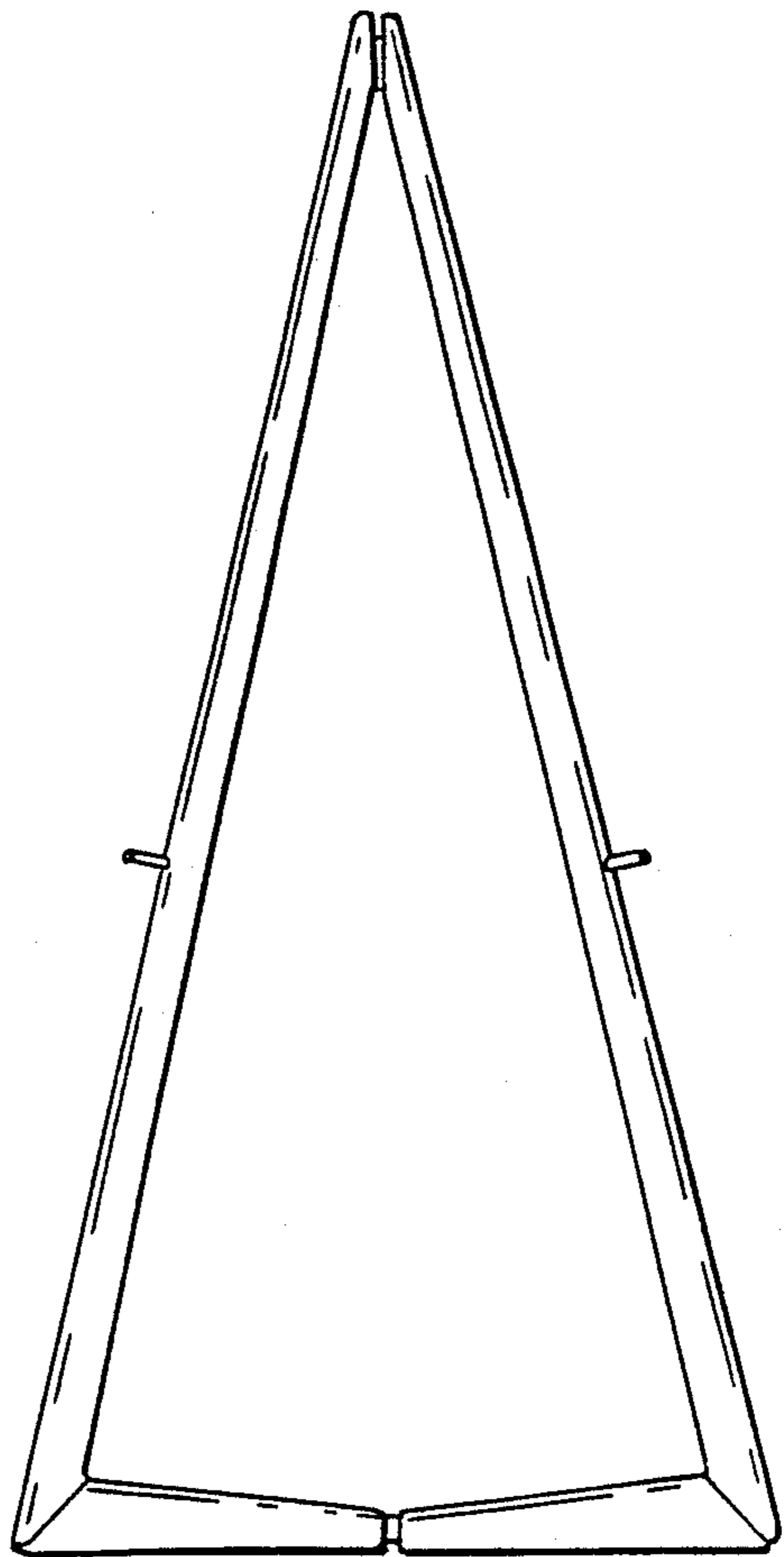

FIG. 5

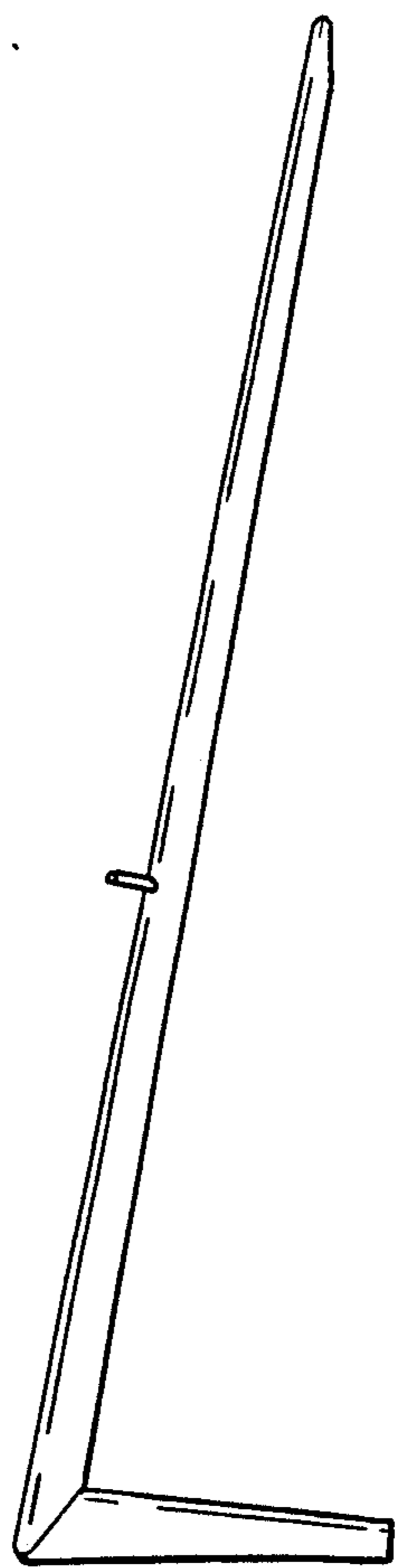

FIG. 3

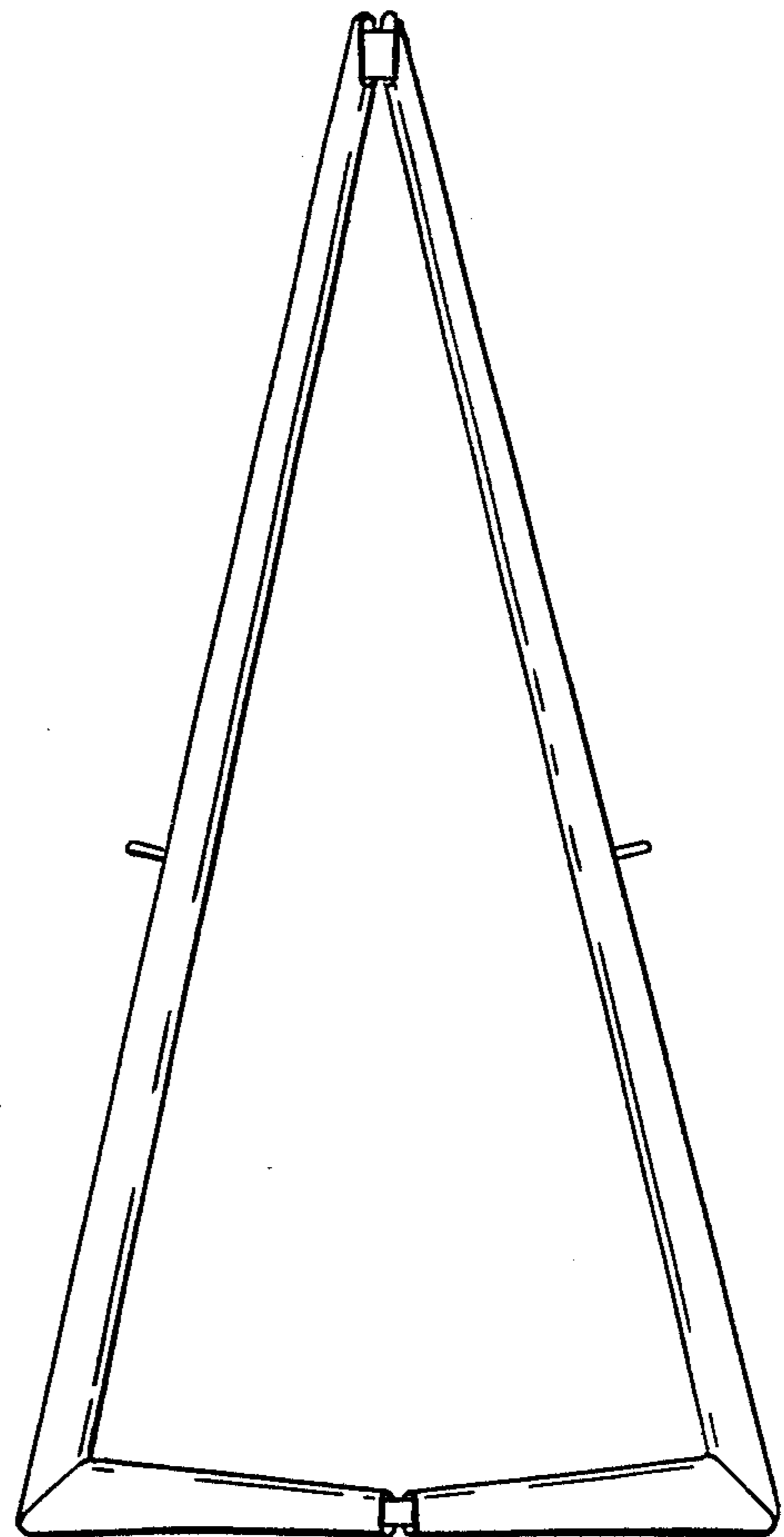

FIG. 4



FIG. 6