

[54] CYLINDER HOUSING

4,632,018 12/1986 Lymburner ..... 92/5

[76] Inventor: Kurt Stoll, Lenzhalde 72, D-7300  
Esslingen, Fed. Rep. of Germany

[\*\*] Term: 14 Years

[21] Appl. No.: 27,291

[22] Filed: Mar. 17, 1987

[30] Foreign Application Priority Data

Oct. 23, 1986 [DE] Fed. Rep. of Germany ..... MR 1523

[52] U.S. Cl. .... D15/7

[58] Field of Search ..... D15/7, 9; 92/5; 91/196;  
417/437, 460

[56] References Cited

U.S. PATENT DOCUMENTS

- D. 264,972 6/1982 McMillan et al. .... D15/7
- D. 295,753 5/1988 LaBair ..... D15/7
- 385,319 6/1888 North ..... D15/7 X

OTHER PUBLICATIONS

Bellows-Valvair brochure (1966)-Air Motor.

Primary Examiner—Wallace R. Burke

Assistant Examiner—Brian N. Vinson

Attorney, Agent, or Firm—Flynn, Thiel, Boutell & Tanis

[57] CLAIM

The ornamental design for a cylinder housing, as shown and described.

DESCRIPTION

FIG. 1 is a top and left end perspective view of a cylinder housing.

FIG. 2 is a bottom and left end perspective view thereof;

FIG. 3 is a top and right end perspective view thereof; and

FIG. 4 is a bottom and right end perspective view thereof.

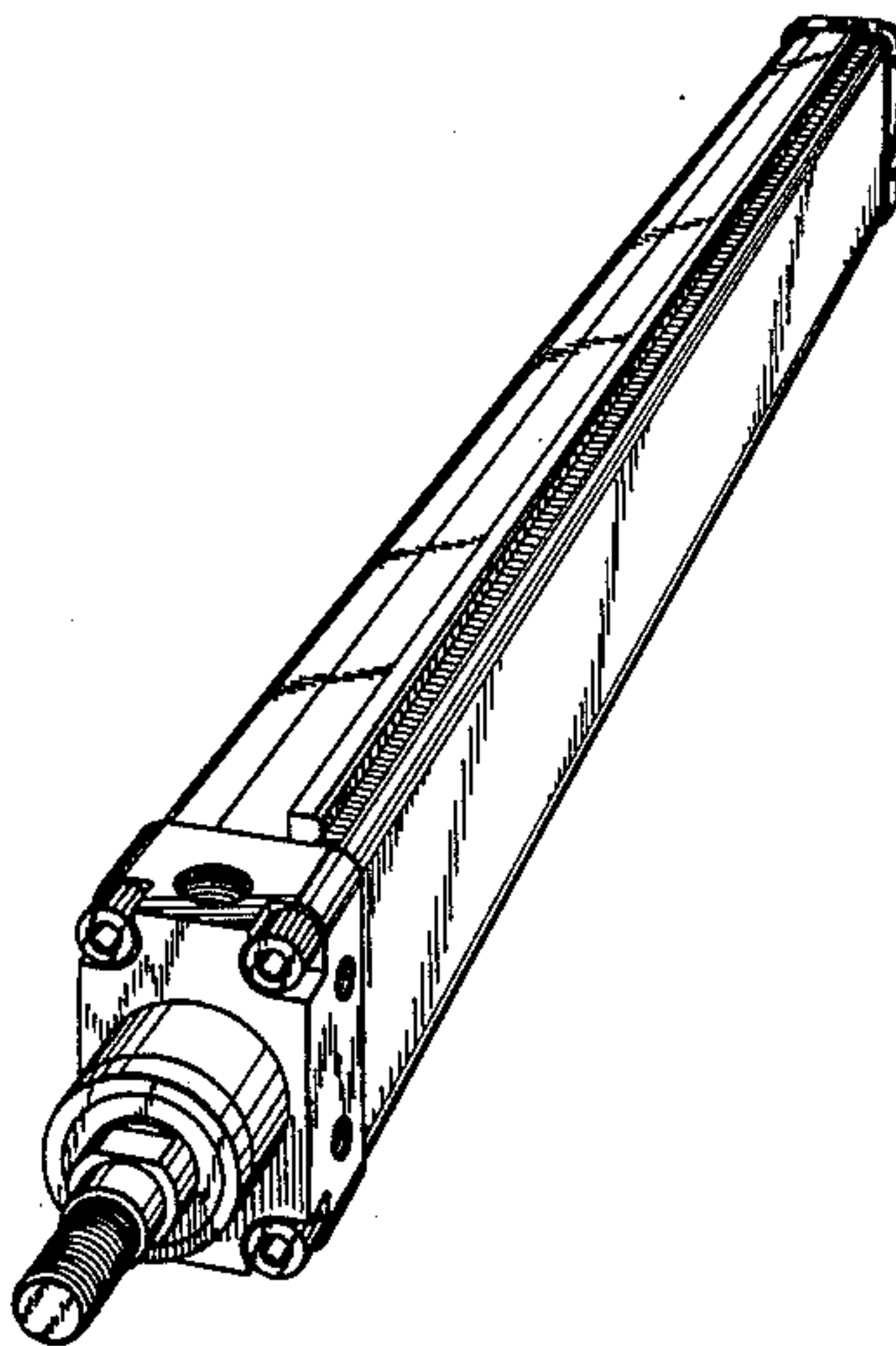

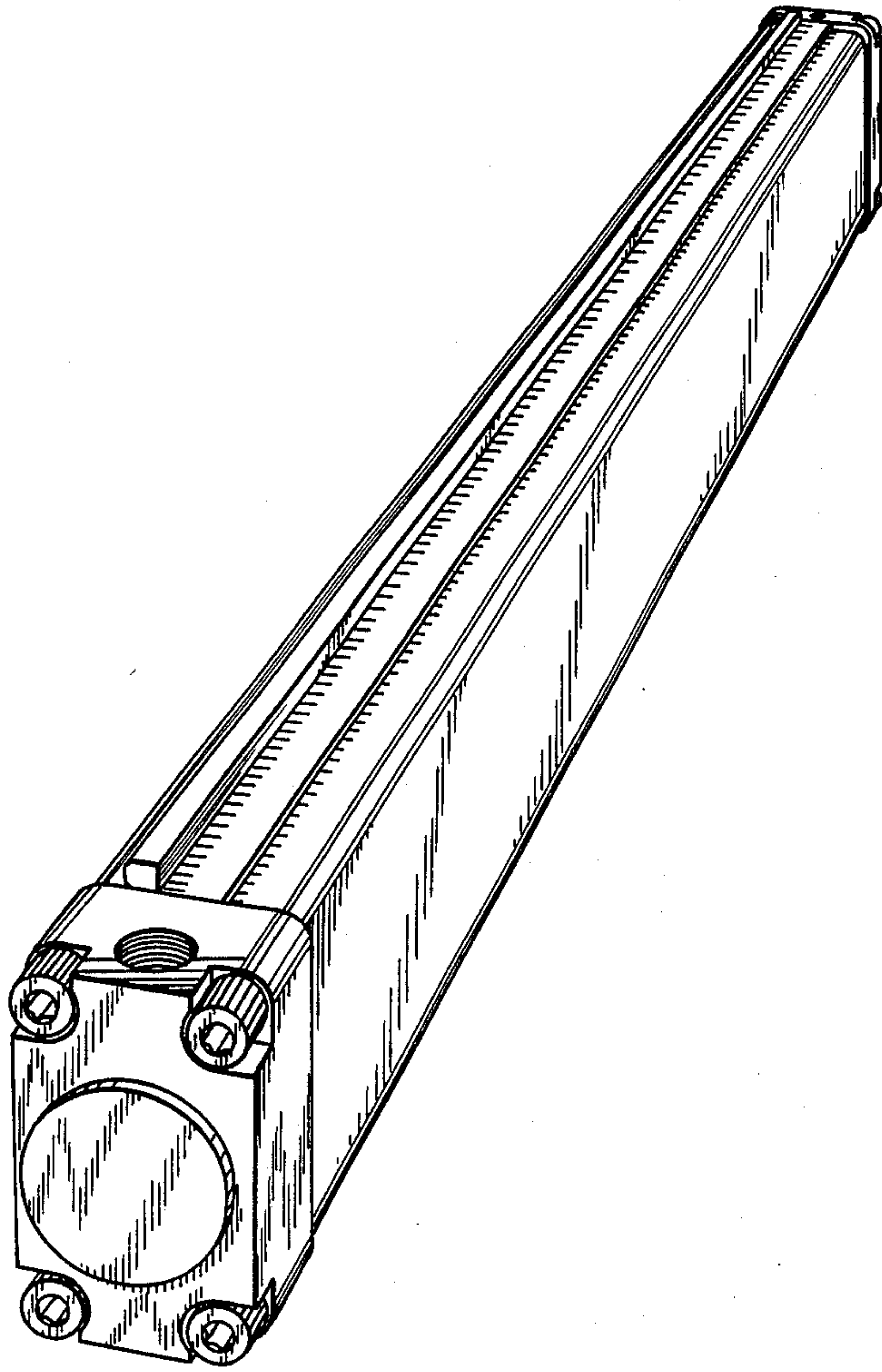

FIG. 1

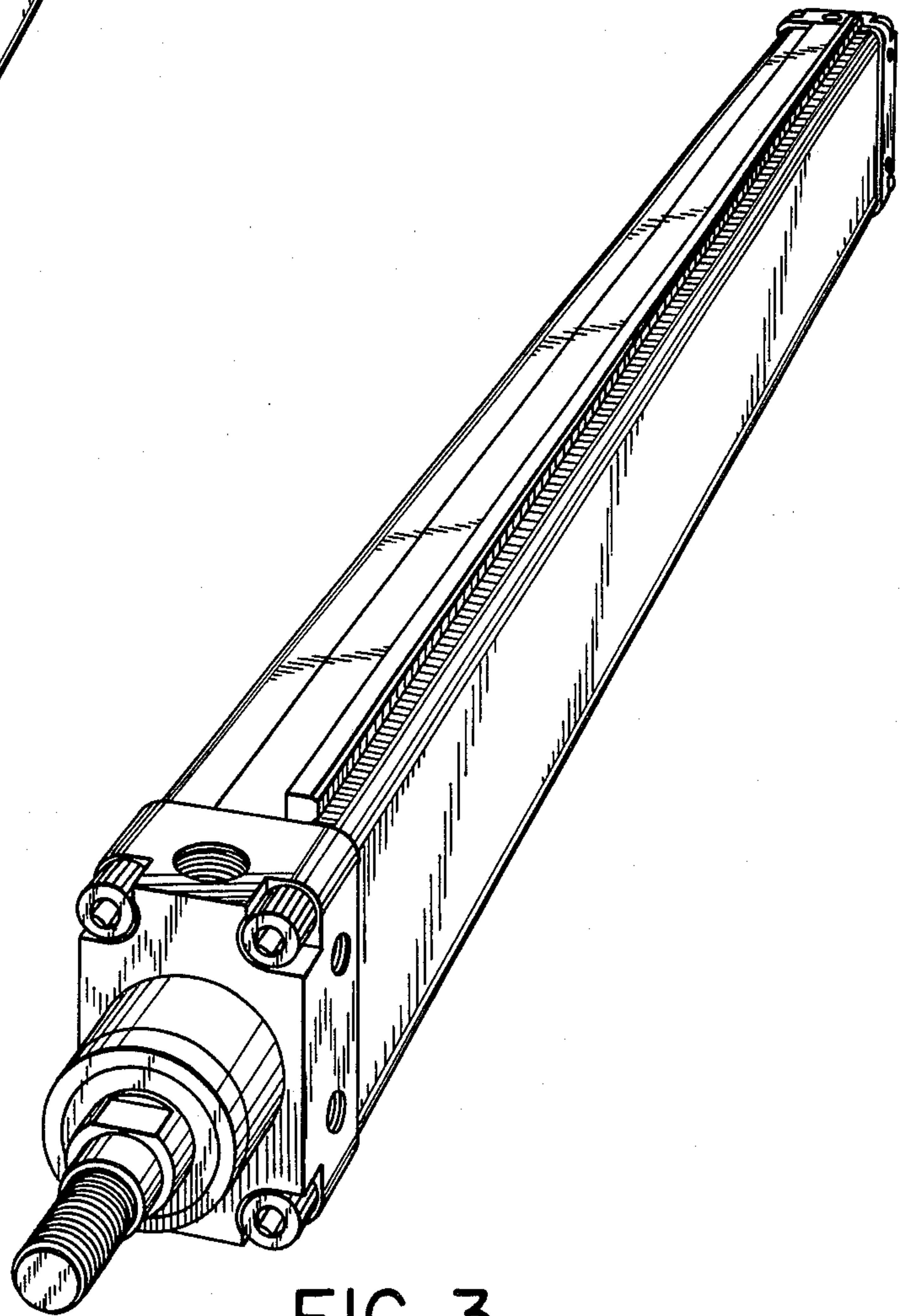

FIG. 3

FIG. 2

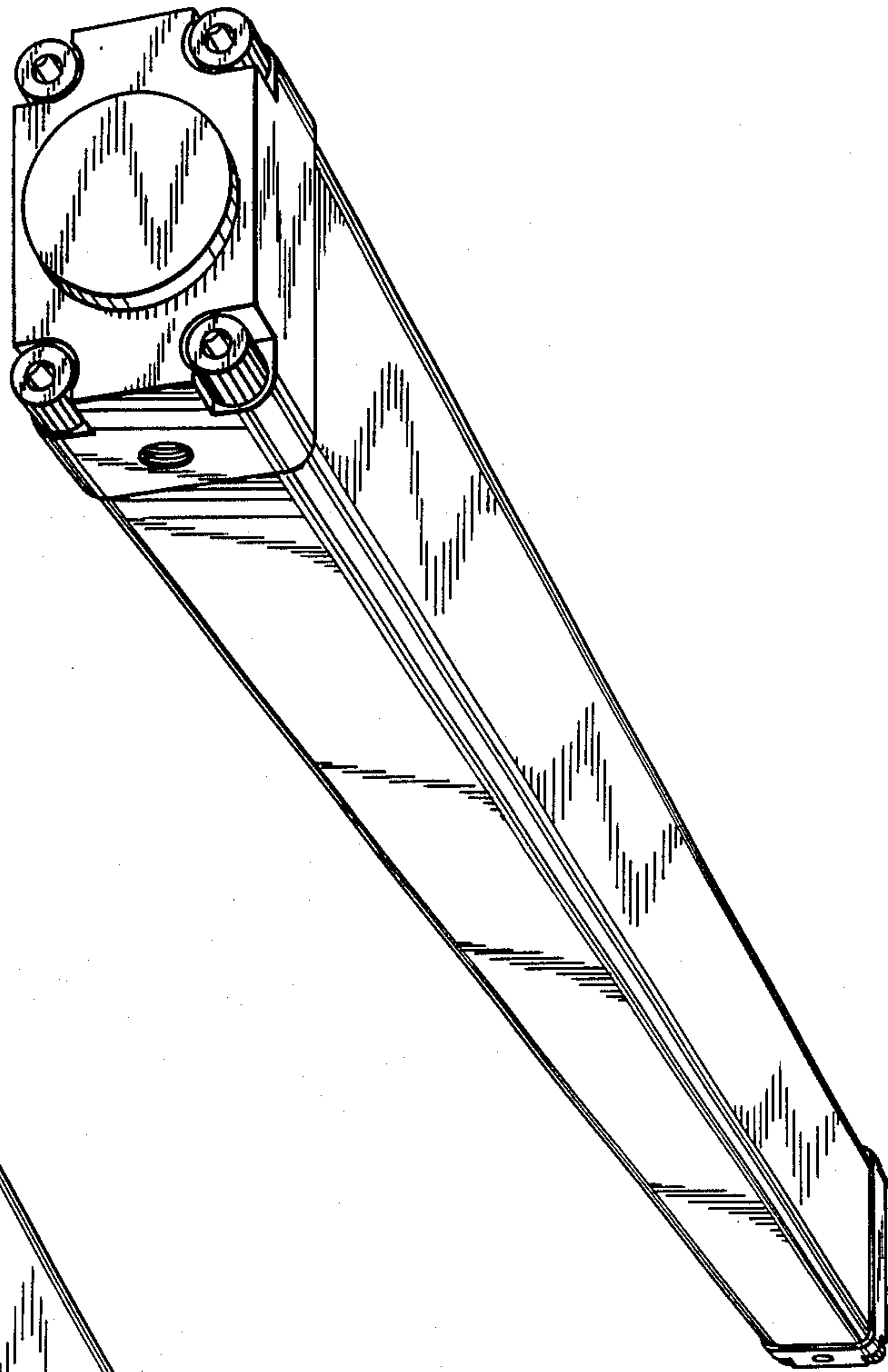

FIG. 4

