

[54] COMBINED CAP AND STEREO

1,148,586 8/1915 Henderson 2/195
2,556,807 6/1951 Goldman 2/197
3,766,565 10/1973 Cozzens 2/195 X

[76] Inventor: Donald L. Pridgen, 816 W. Main St.,
Clinton, N.C. 28328

[**] Term: 14 Years

[21] Appl. No.: 883,136

[22] Filed: Jul. 8, 1986

[52] U.S. Cl. D2/246

[58] Field of Search D2/244, 245, 246, 247,
D2/248, 253; 2/198, 199, 200, 195, 197;
D14/70

OTHER PUBLICATIONS

Helen-Gallagher-Foster House 1966-1967, p. 22; Tran-
sistor Radio Car, far left second from top.

Primary Examiner—Carmen H. Vales-Lado
Attorney, Agent, or Firm—Jerry T. Kearns

[57] CLAIM

The ornamental design for a combined cap and stereo,
as shown and described.

DESCRIPTION

FIG. 1 is a perspective view of a combined cap and
stereo showing my new design;
FIG. 2 is a front elevational view thereof;
FIG. 3 is a left side elevational view thereof;
FIG. 4 is a right side elevational view thereof;
FIG. 5 is a top plan view thereof;
FIG. 6 is a bottom plan view thereof.

[56] References Cited

U.S. PATENT DOCUMENTS

- D. 134,878 1/1943 Grice D2/244
- D. 258,433 3/1981 Bulmash et al. D2/253 X
- D. 262,455 12/1981 Bulmash et al. D2/247 X
- D. 267,752 2/1983 Fairbrother D2/244 X
- D. 280,861 10/1985 Giraud et al. D2/244
- D. 290,422 6/1987 Brouman D2/246

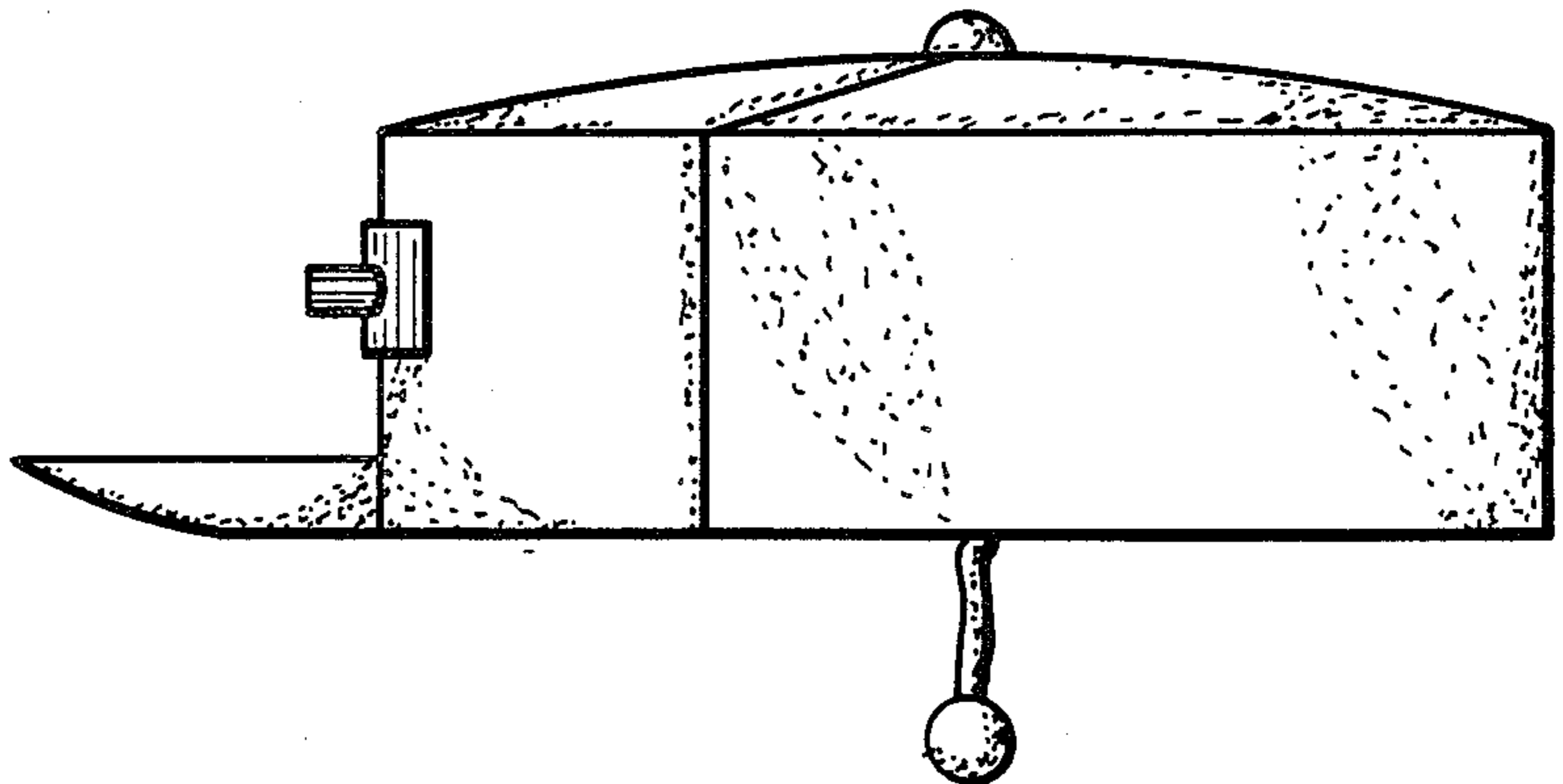
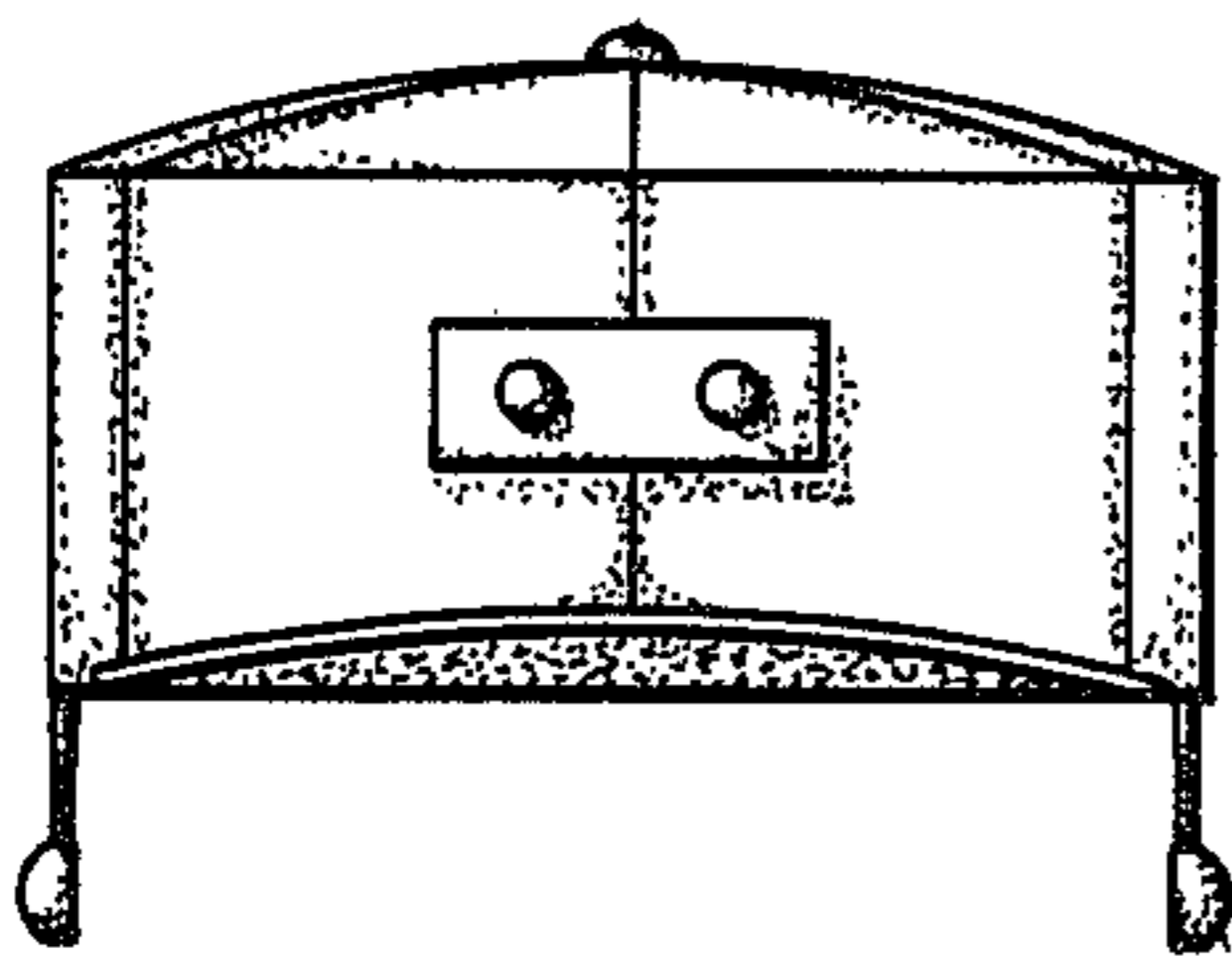
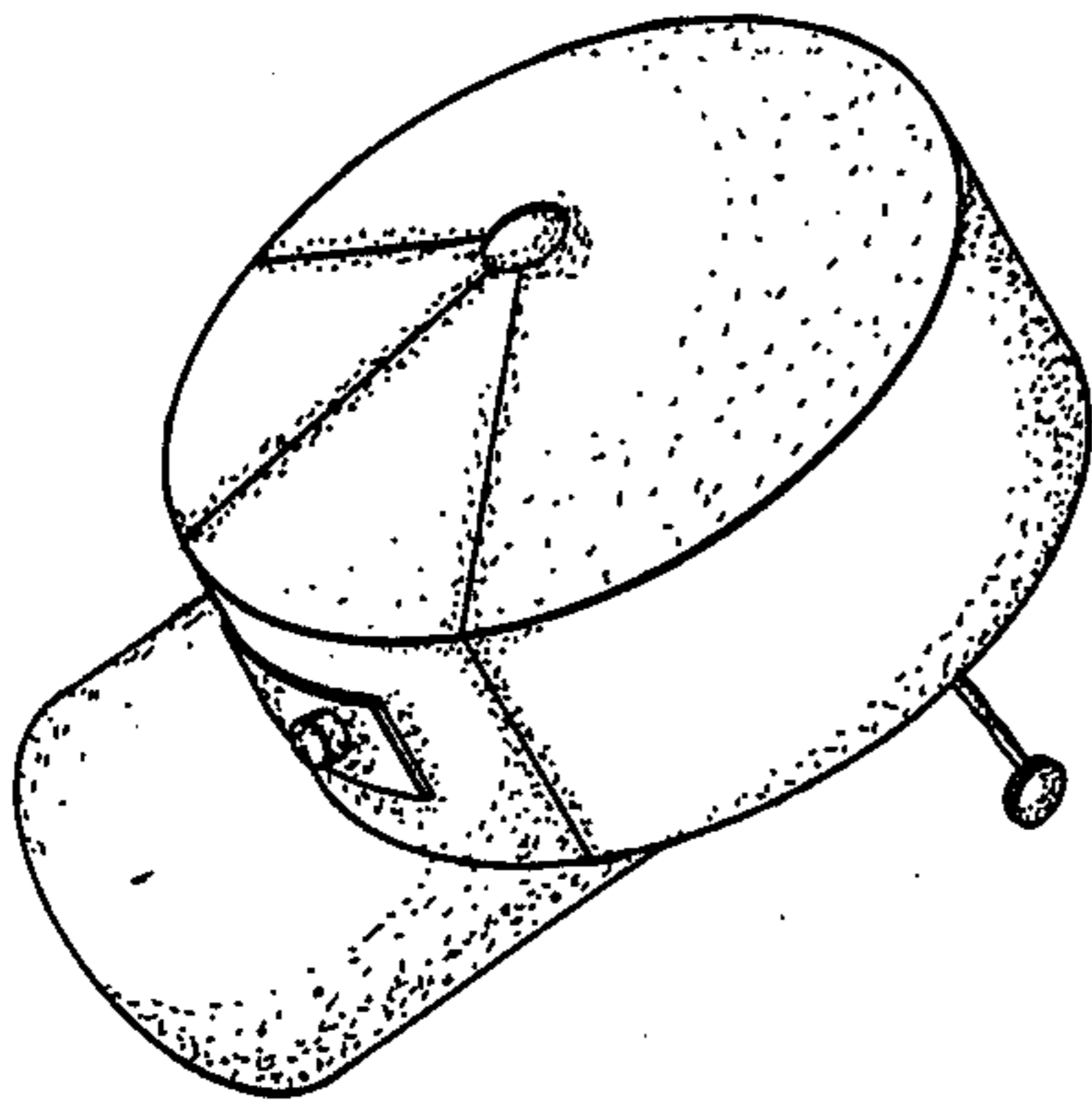

FIG 1

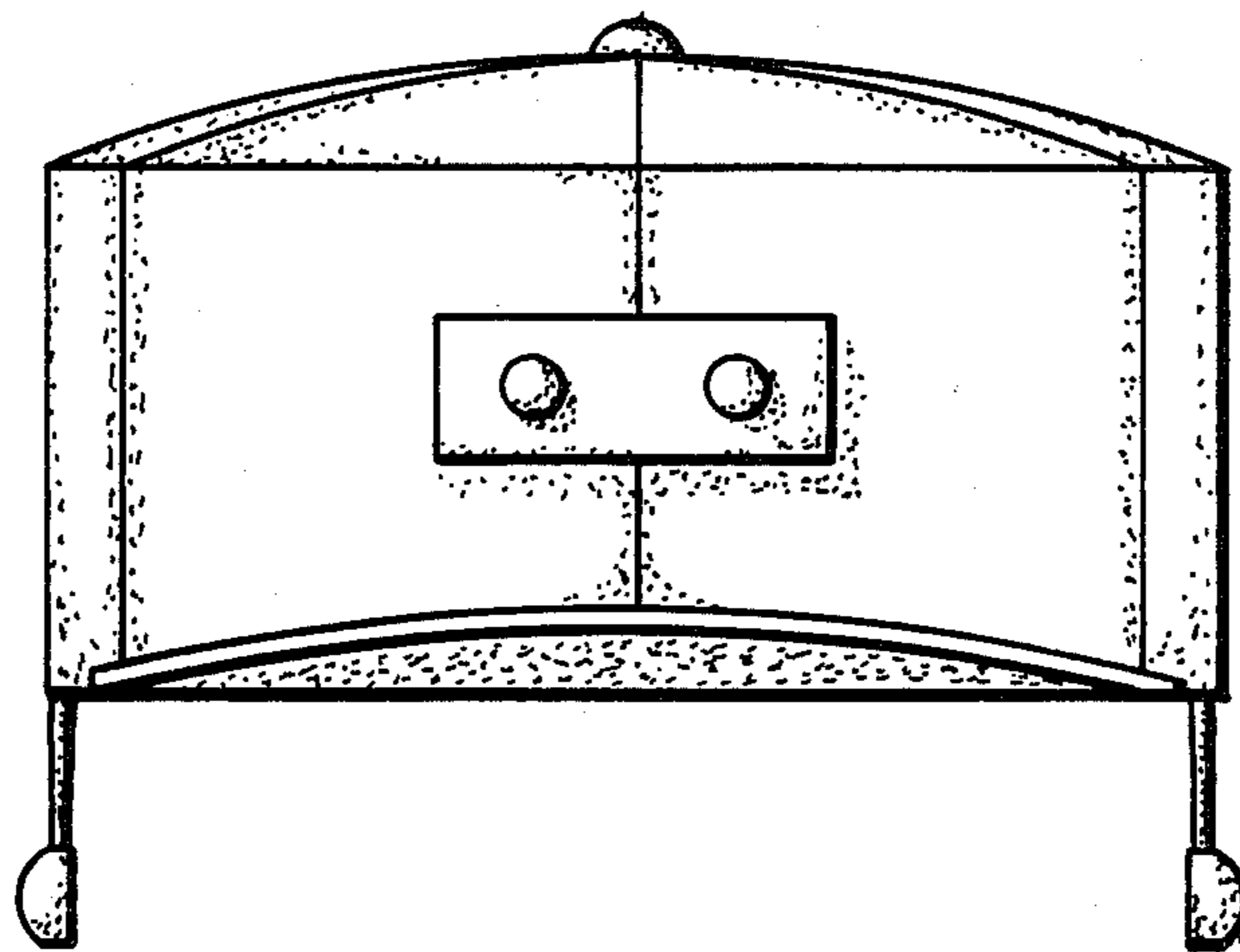
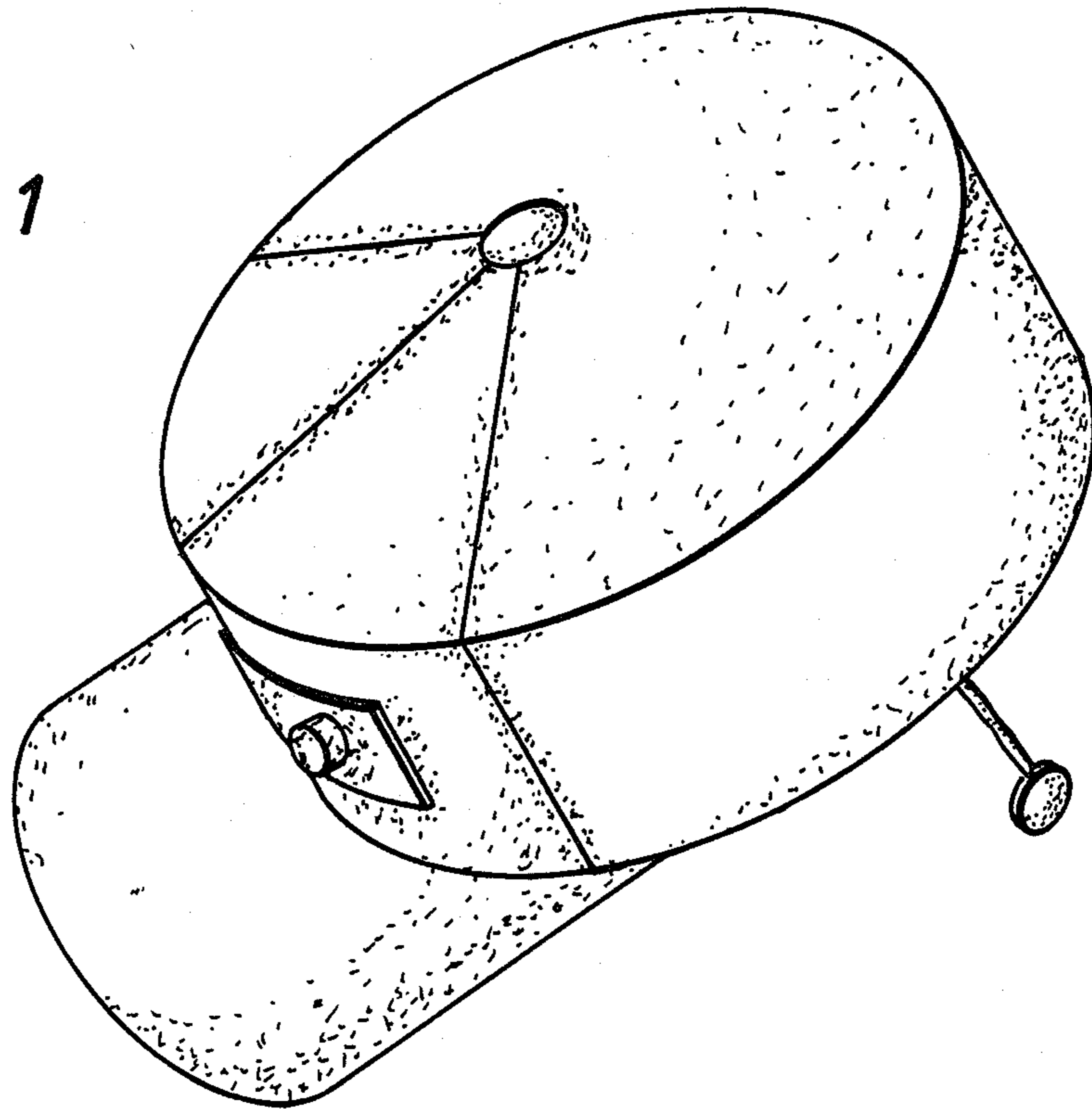

FIG 2

FIG 6

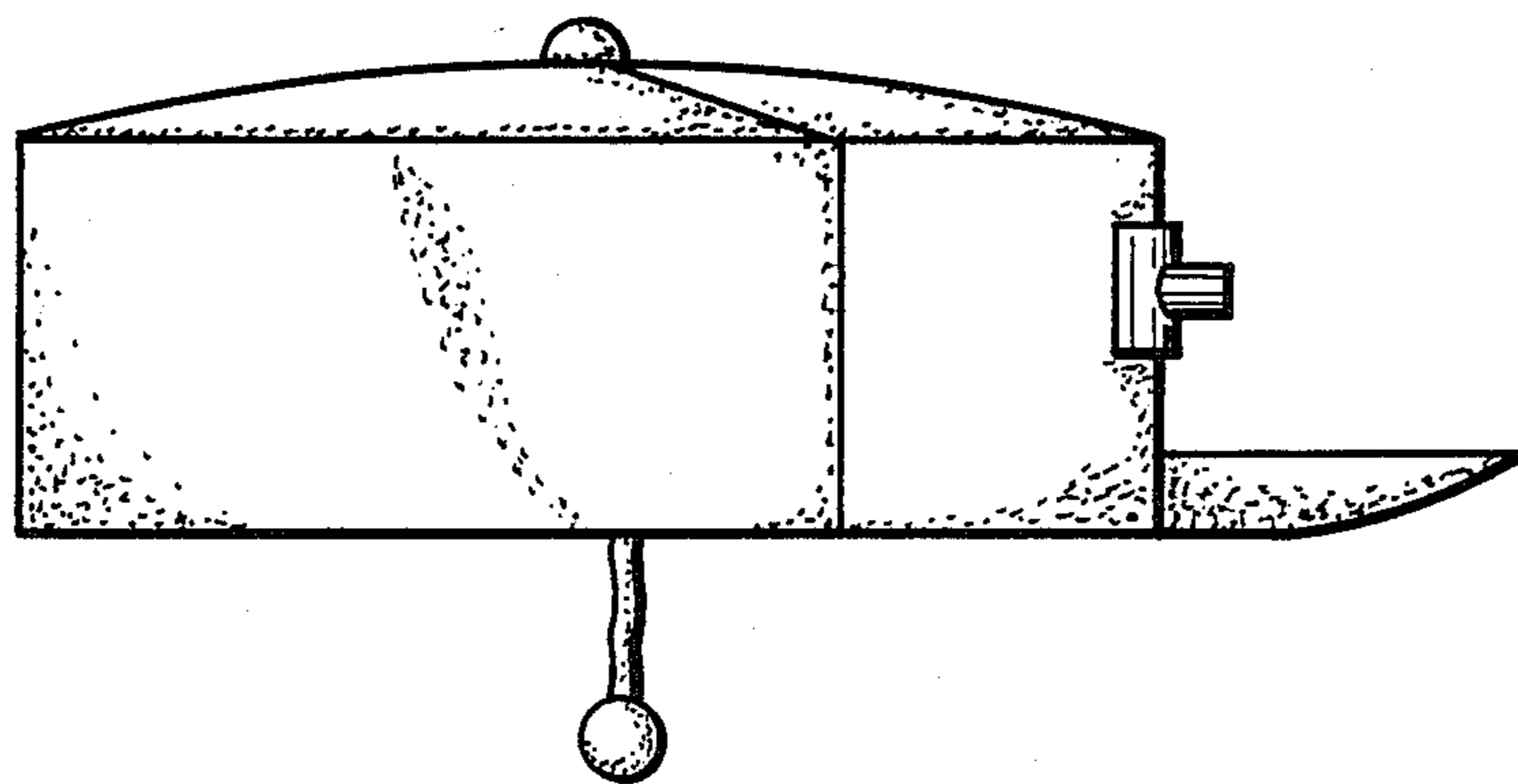
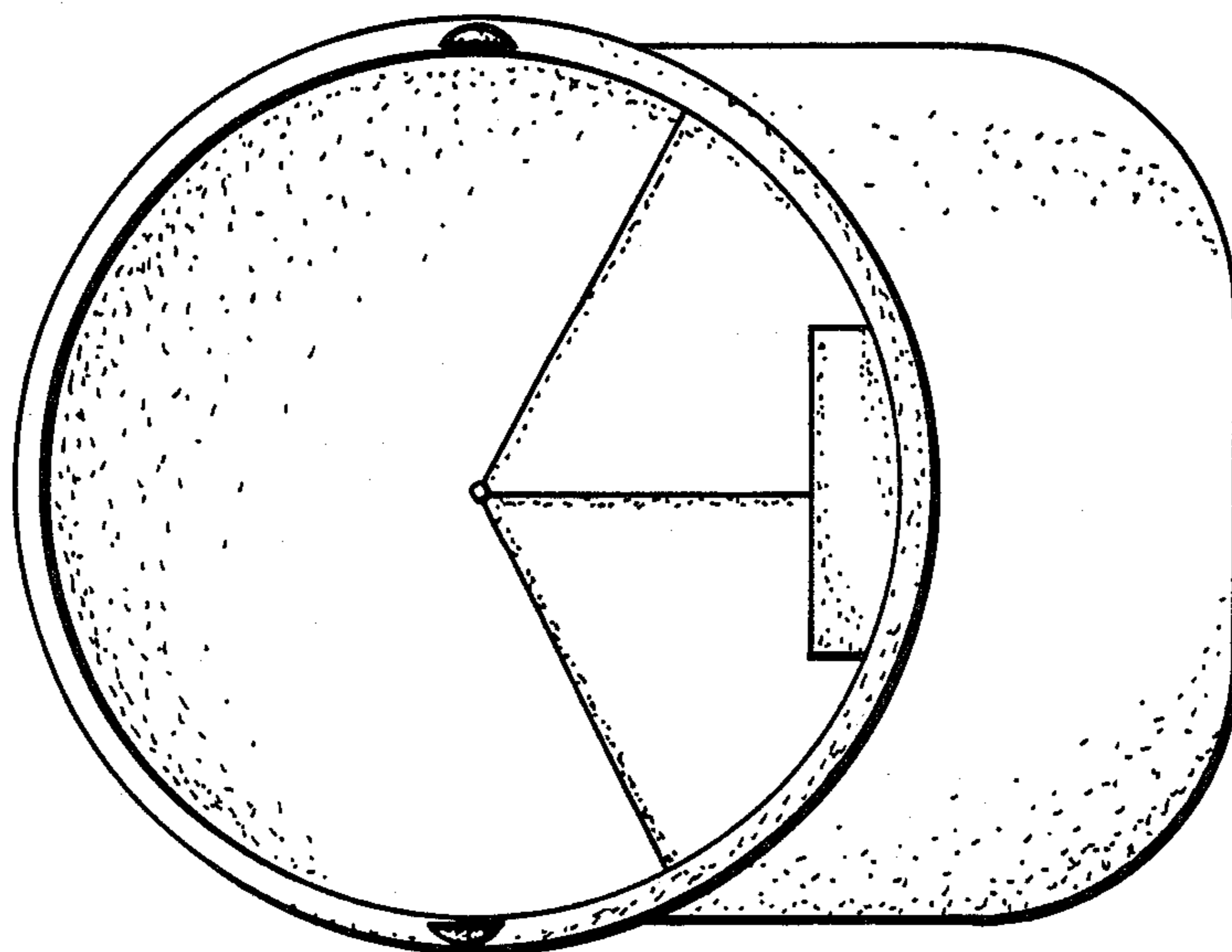

FIG 3

FIG 5

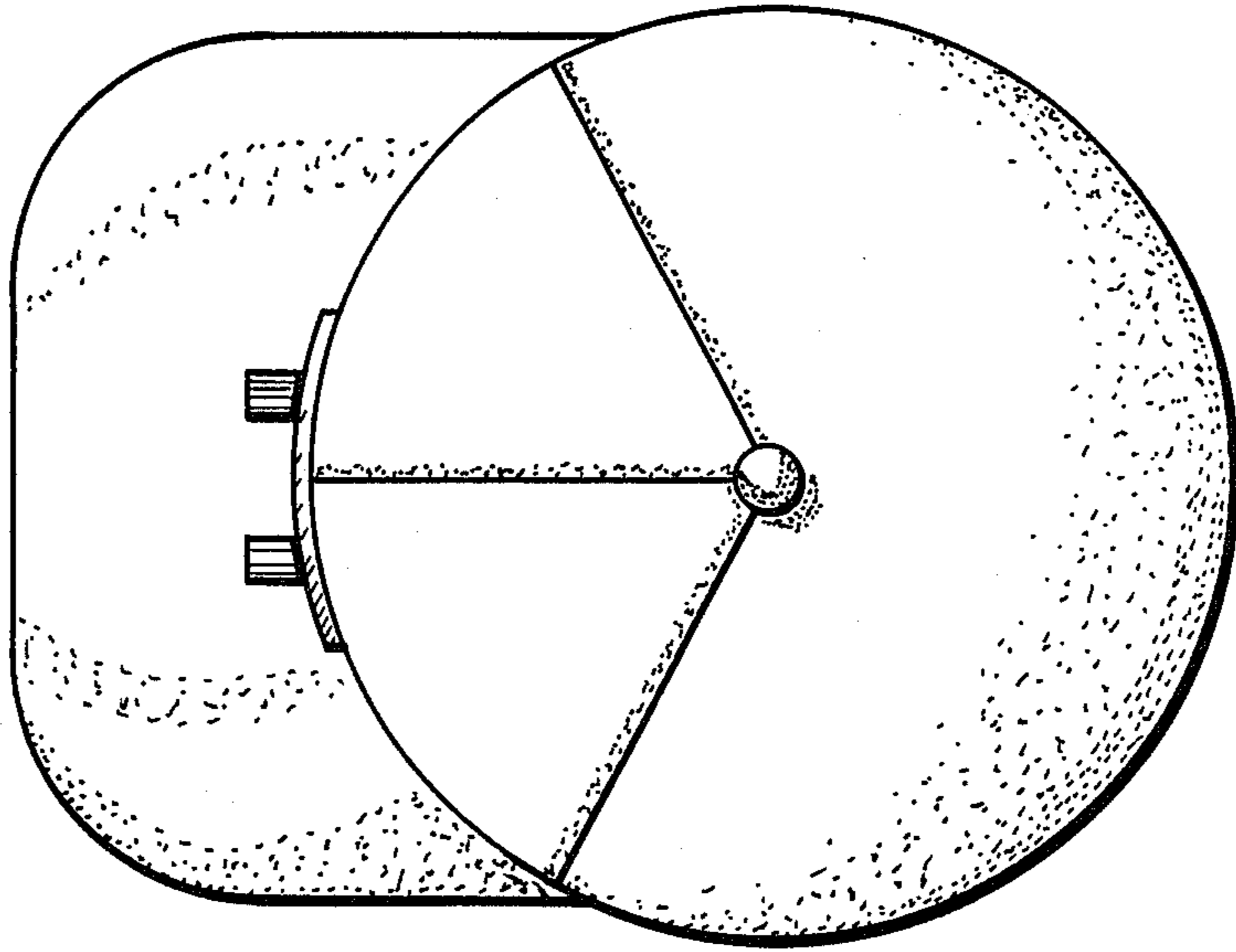

FIG 4

