

[54] ENDLESS TRACK WHEEL GUIDE

[76] Inventor: Edouard M. Comellas, 2146 Chemis Aubin, Bernieres, P.Q., Canada, G0S 1C0

[**] Term: 14 Years

[21] Appl. No.: 819,934

[22] Filed: Jan. 21, 1986

[52] U.S. Cl. D15/28; 16/90; D8/380

[58] Field of Search D15/28, 24; D8/354; 16/90, 91

[56] References Cited

U.S. PATENT DOCUMENTS

- D. 218,158 7/1970 Comellas D15/28
- 444,274 1/1891 Cole et al. 16/90
- 527,792 10/1894 Hill 16/90

- 705,081 7/1902 Hennessey 16/90
- 943,039 12/1909 McGuire 16/90
- 1,560,828 11/1925 Kopp 16/90
- 1,737,227 11/1927 Eklind et al. 16/90
- 3,000,046 9/1961 Foltz 16/90

Primary Examiner—Horace B. Fay, Jr.
Attorney, Agent, or Firm—Pettis & McDonald

[57] CLAIM

The ornamental design for an endless track wheel guide, as shown and described.

DESCRIPTION

- FIG. 1 is a side elevational view of the endless track wheel guide embodying my new design.
- FIG. 2 is a top plan view thereof.
- FIG. 3 is a bottom plan view thereof.
- FIG. 4 is an opposite side elevational view thereof.
- FIG. 5 is a right end elevational view thereof.
- FIG. 6 is a left end elevational view thereof.
- FIG. 7 is a perspective view thereof.

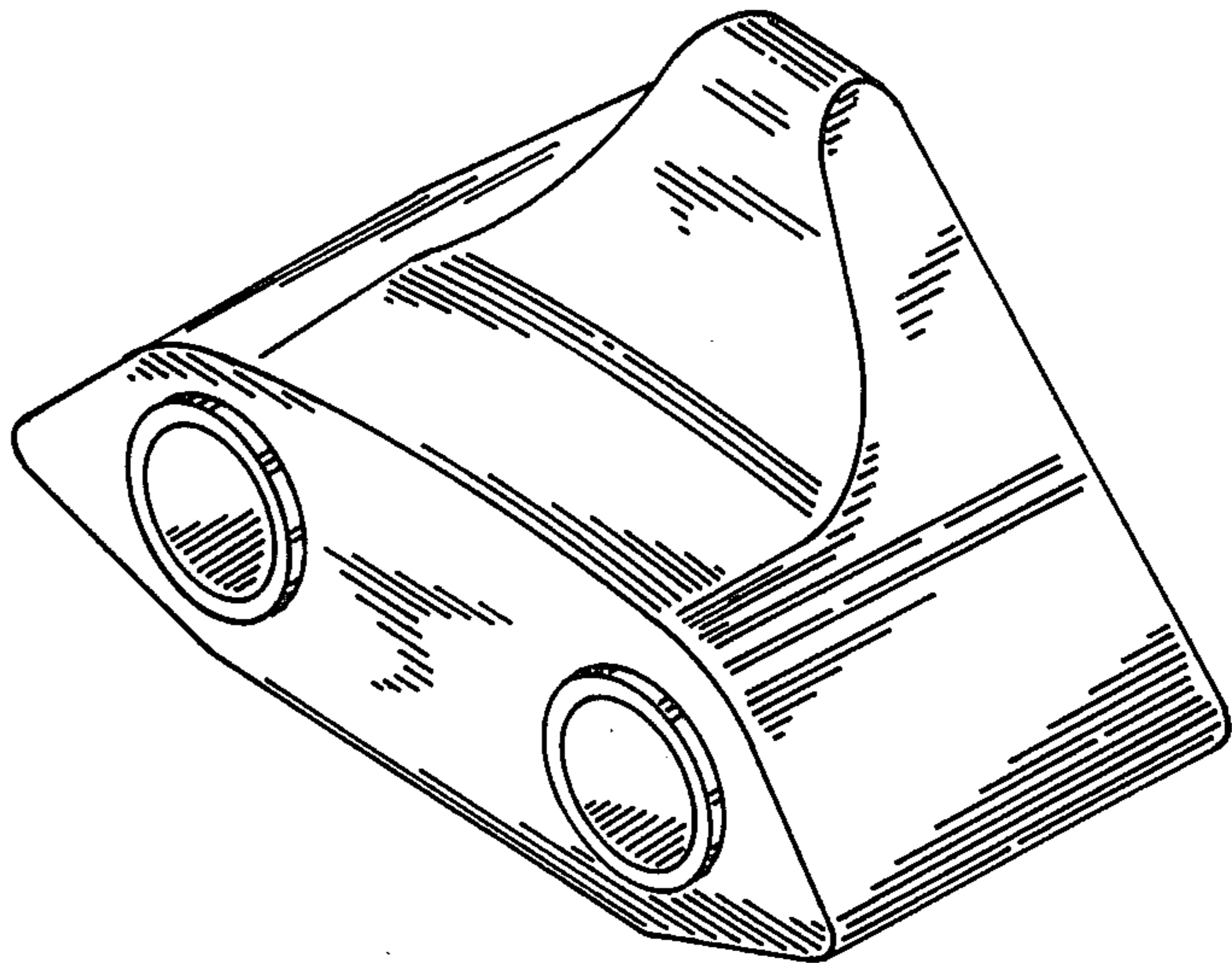
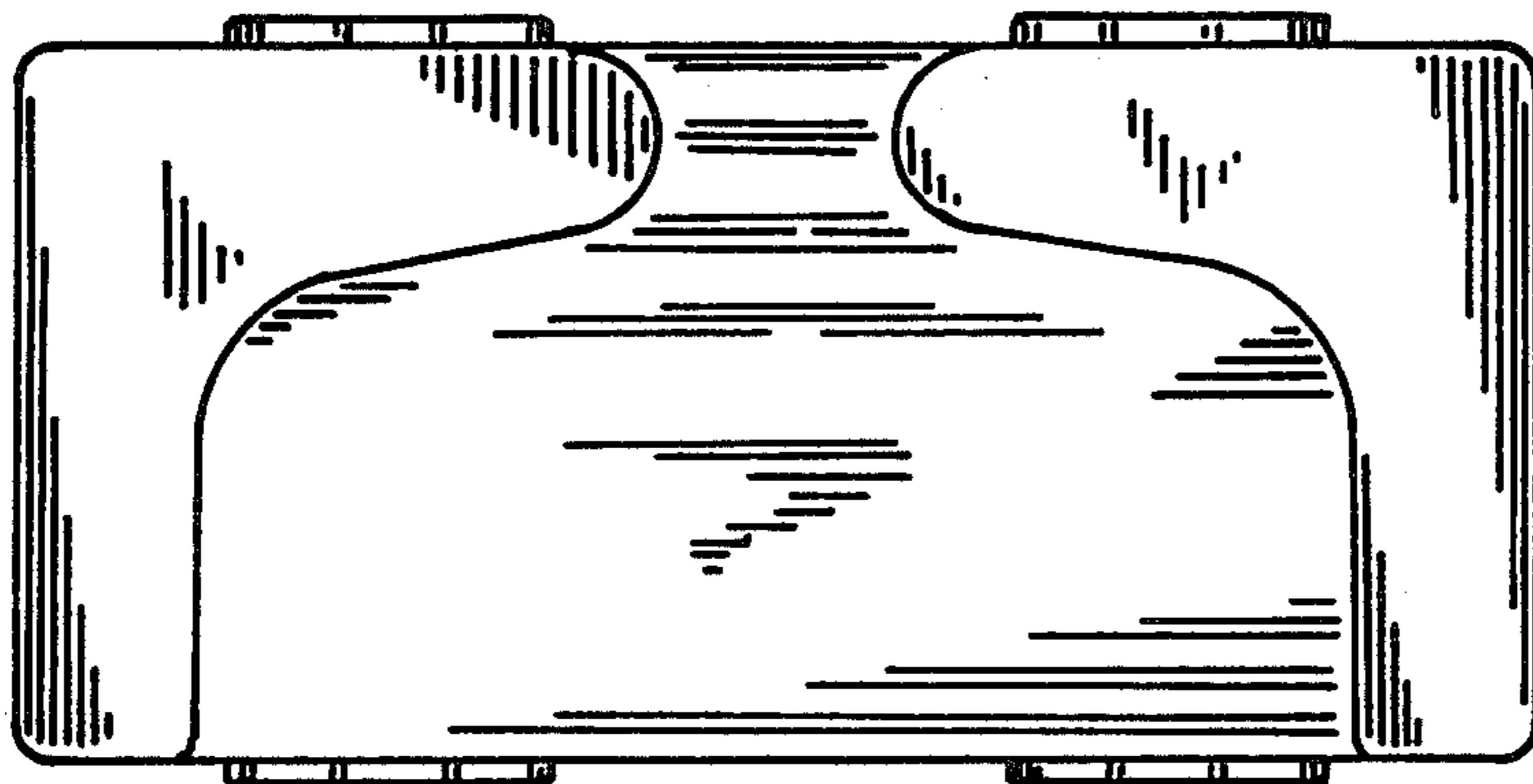

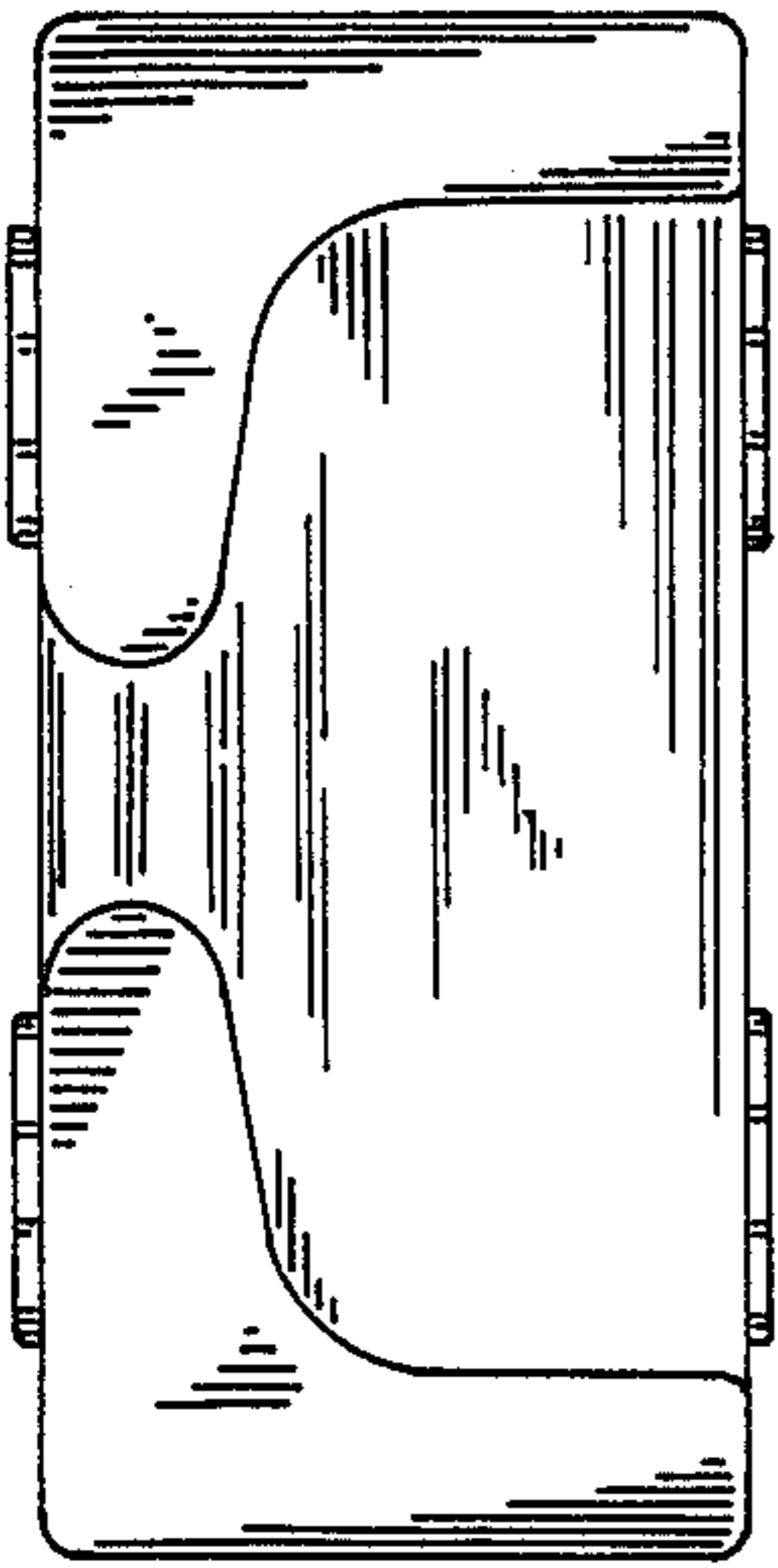

FIG. 2

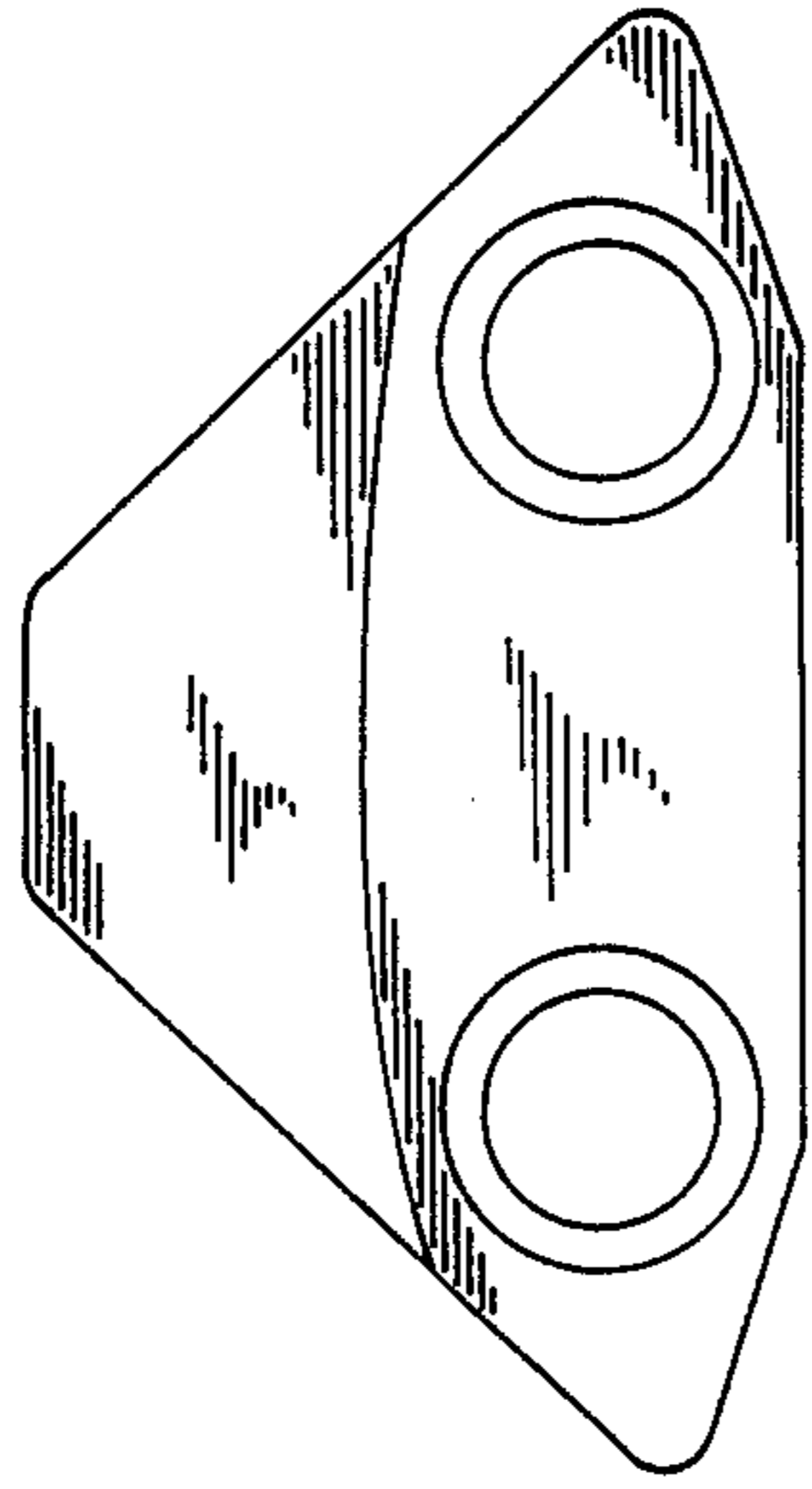

FIG. 1

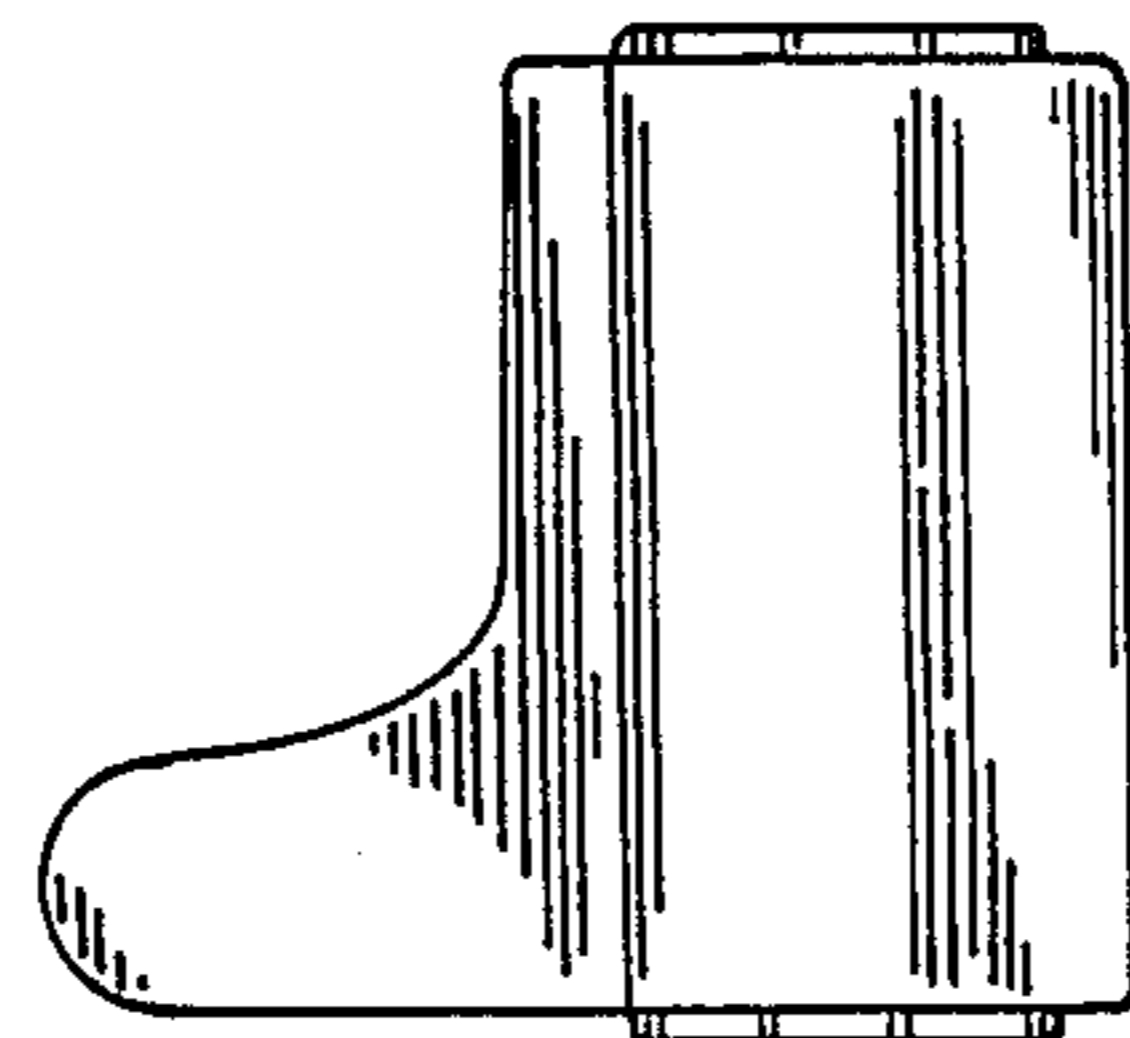

FIG. 6

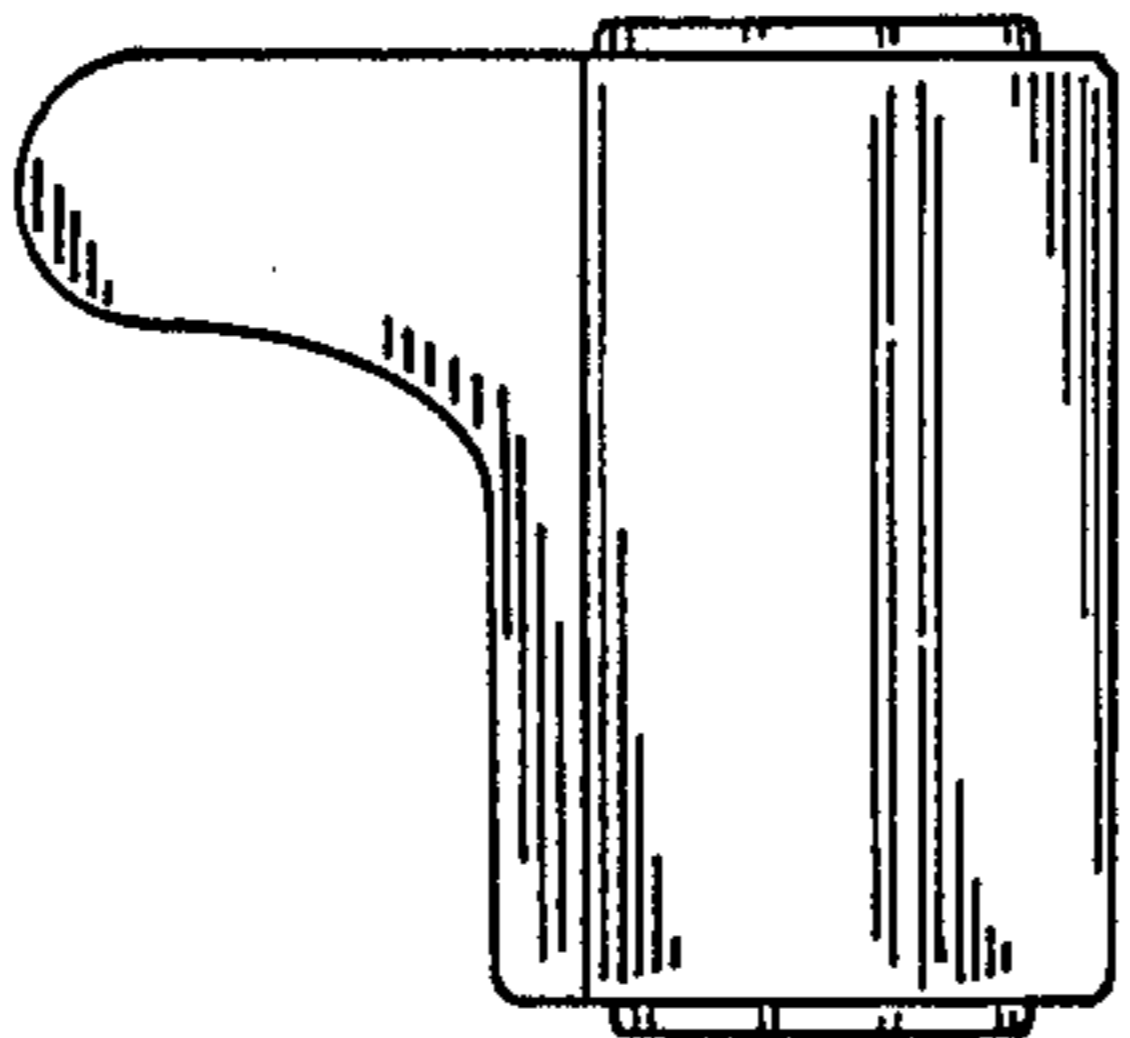

FIG. 5

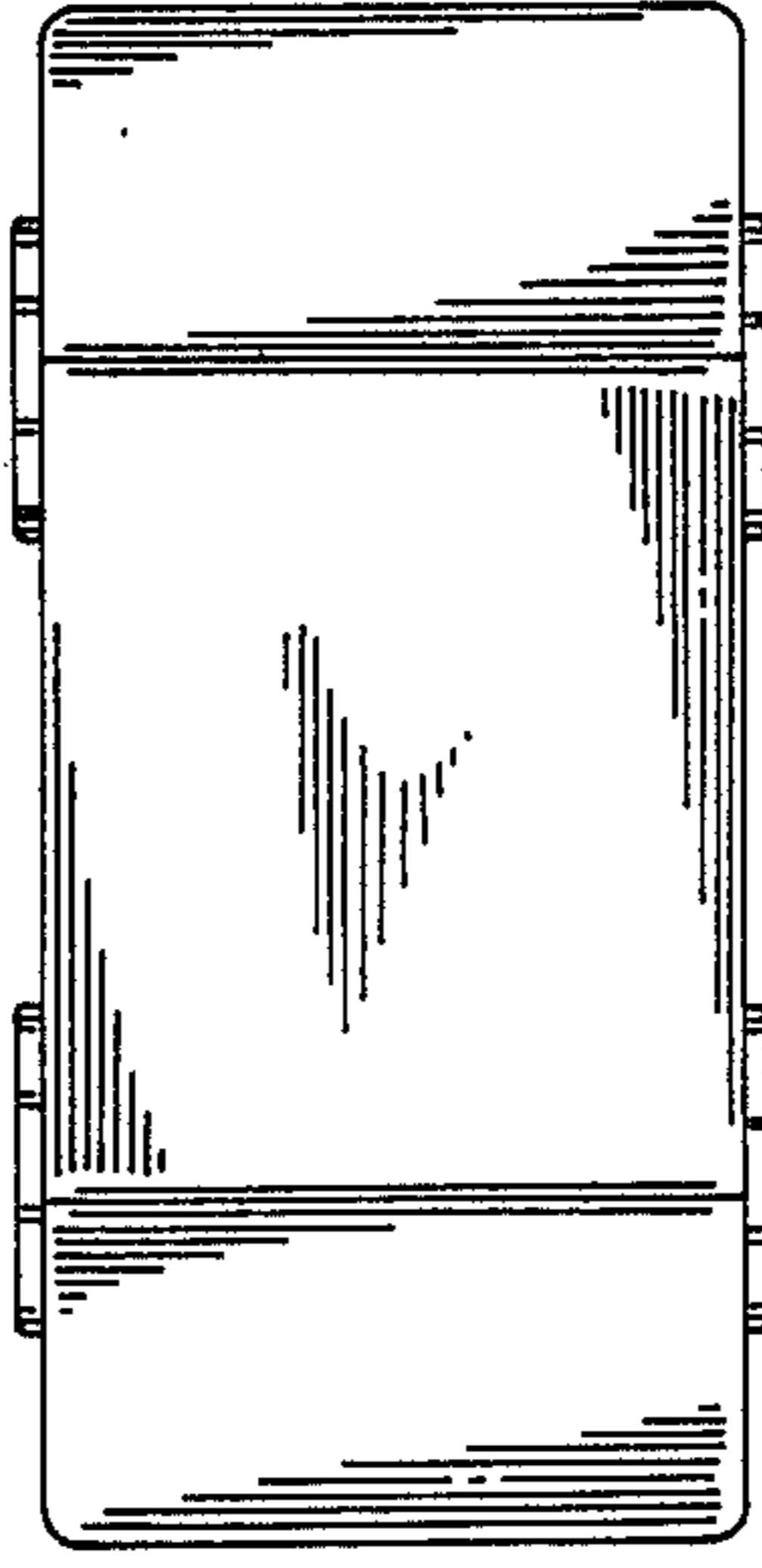

FIG. 3

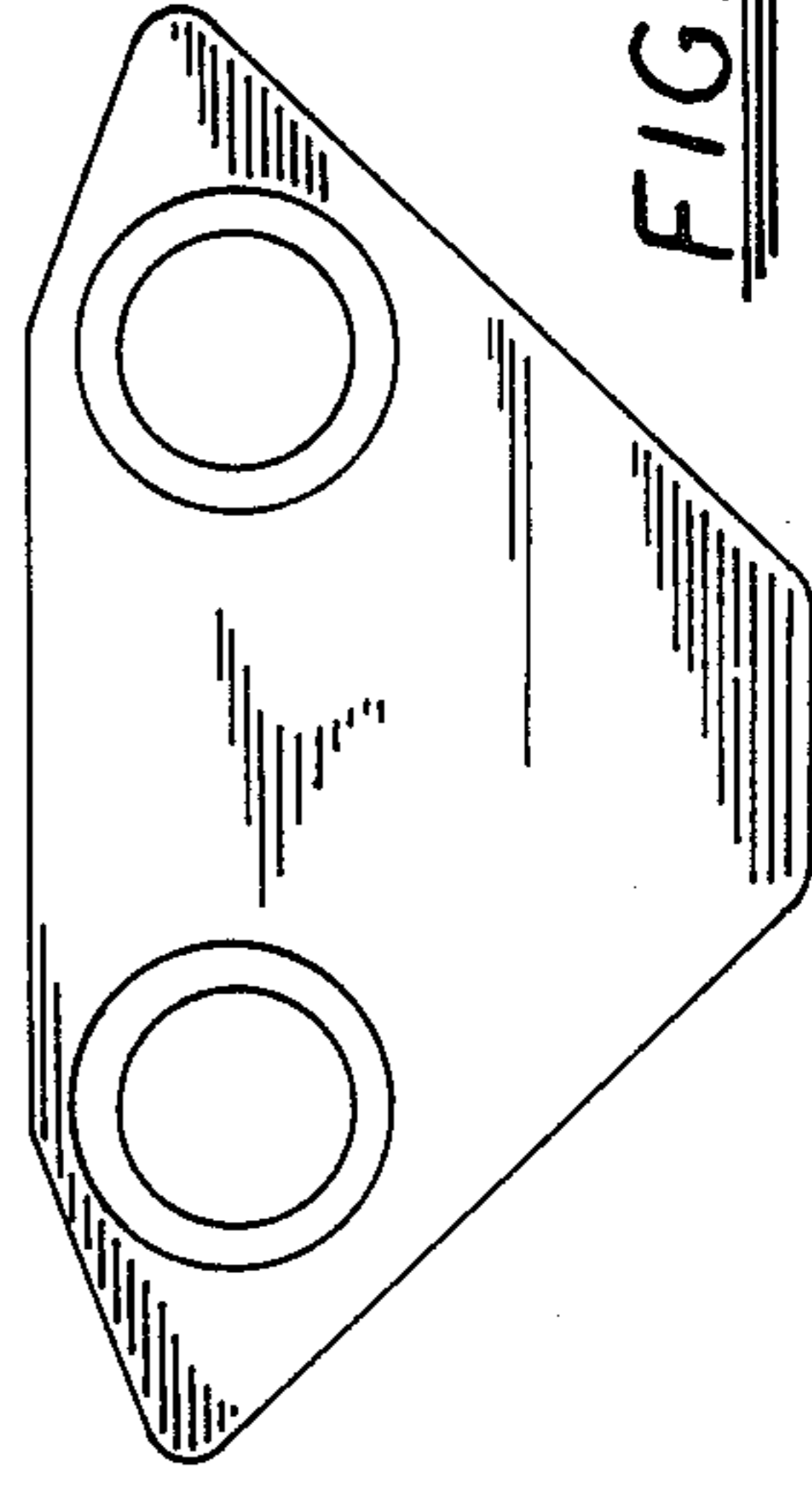

FIG. 4

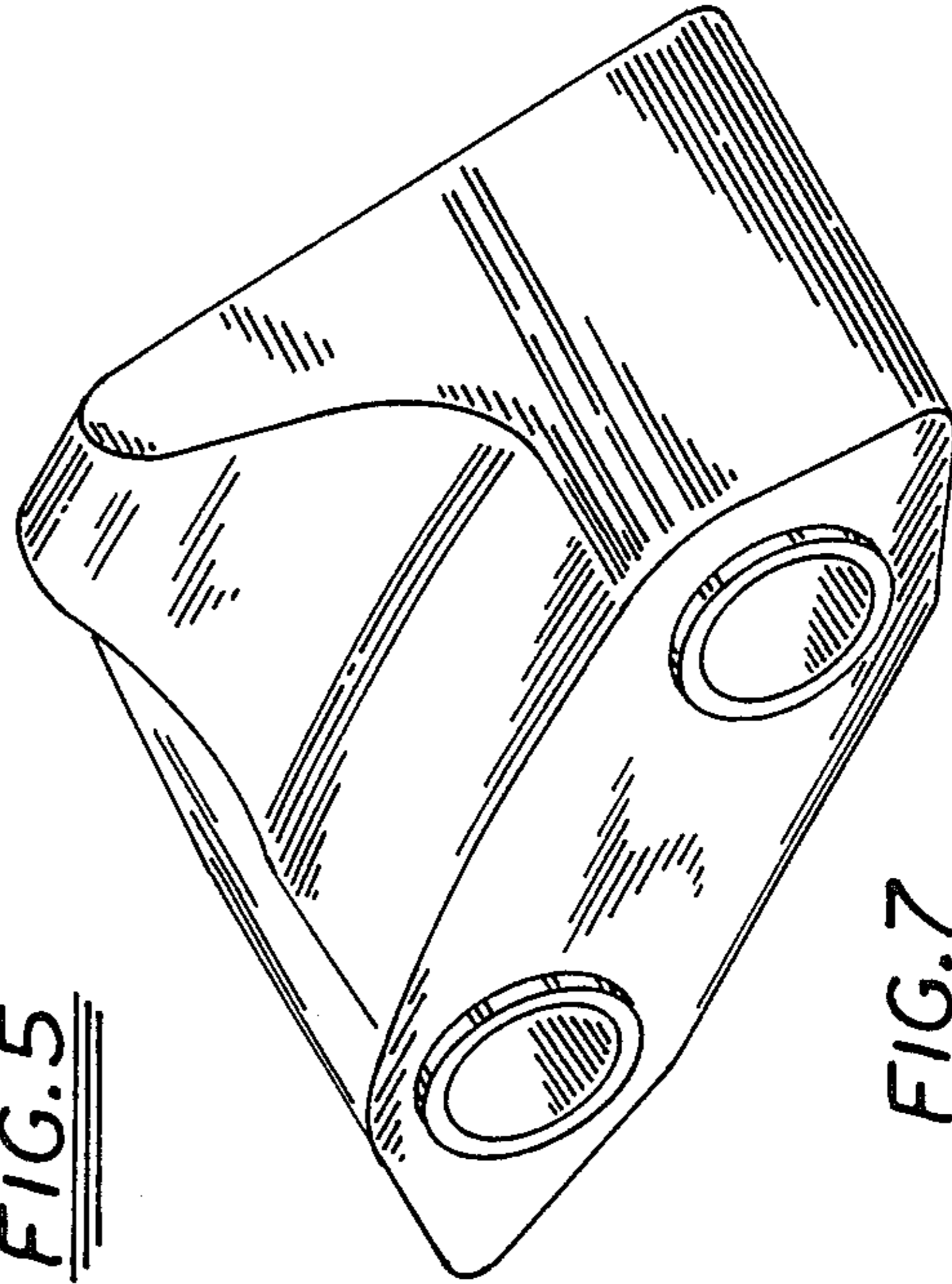

FIG. 7