

[54] VEHICLE QUARTER FENDER

[75] Inventors: Timothy R. Hawes, Muskegon; Steven A. Antekeier, North Shores; Glenn R. Cryderman; David I. Munger, both of Muskegon; Leonard A. Gould, Fruitport; Louis E. Eklund, Jr., Muskegon, all of Mich.

[73] Assignee: Fleet Enginners, Inc., Muskegon, Mich.

[\*\*] Term: 14 Years

[21] Appl. No.: 851,359

[22] Filed: Apr. 9, 1986

[52] U.S. Cl. .... D12/185

[58] Field of Search ..... D12/185; 280/154.5 R, 280/152

[56] References Cited

U.S. PATENT DOCUMENTS

Re. 24,339	7/1957	La Pere	280/152
D. 205,137	6/1966	Weasel, Jr.	D12/185
2,557,147	6/1951	Schatzman	280/153
2,914,341	11/1959	Martt	280/152
2,972,149	2/1961	Bracesco	280/152
3,337,238	8/1967	Weasel, Jr.	280/154.5 R
3,497,237	2/1970	Vis	280/152
3,506,282	4/1970	Miyanaga	280/152
3,922,003	11/1975	Lea	280/154.5 R

4,148,373	4/1979	Cline	280/154.5 R
4,268,053	5/1981	Toppins et al.	280/154
4,377,294	3/1983	Lockwood et al.	280/154.5 R
4,706,980	11/1987	Hawes et al.	280/154.5 R

OTHER PUBLICATIONS

Life-Time Fenders Brochure, 9/83, Vehicle Quarter Fenders.

Fleetline Brochure, ©1983, Vehicle Quarter Fenders.

Primary Examiner—James M. Gandy

Attorney, Agent, or Firm—Varnum, Riddering, Schmidt & Howlett

[57] CLAIM

The ornamental design for a vehicle quarter fender, as shown and described.

DESCRIPTION

FIG. 1 is a perspective view of a vehicle quarter fender showing our new design;

FIG. 2 is an enlarged right side elevation view thereof;

FIG. 3 is an enlarged left side elevation view thereof;

FIG. 4 is an enlarged top plan view thereof;

FIG. 5 is an enlarged bottom plan view thereof; and

FIG. 6 is a perspective view of a vehicle quarter fender showing a second embodiment of our new design the sole difference being in the omission of the top front deflector shield.

The broken lines in the drawing are for illustrative purposes only and form no part of the claimed design.

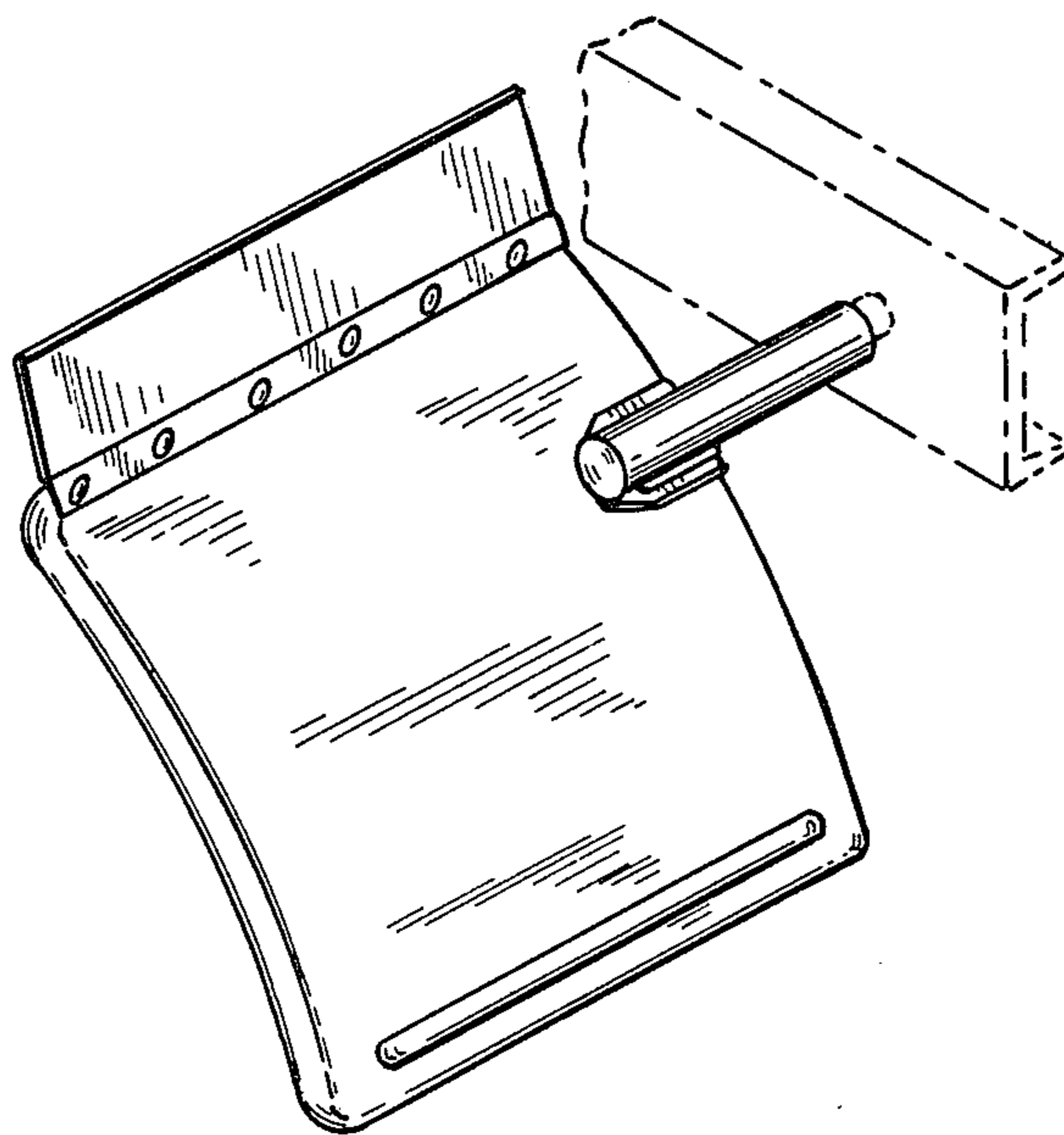

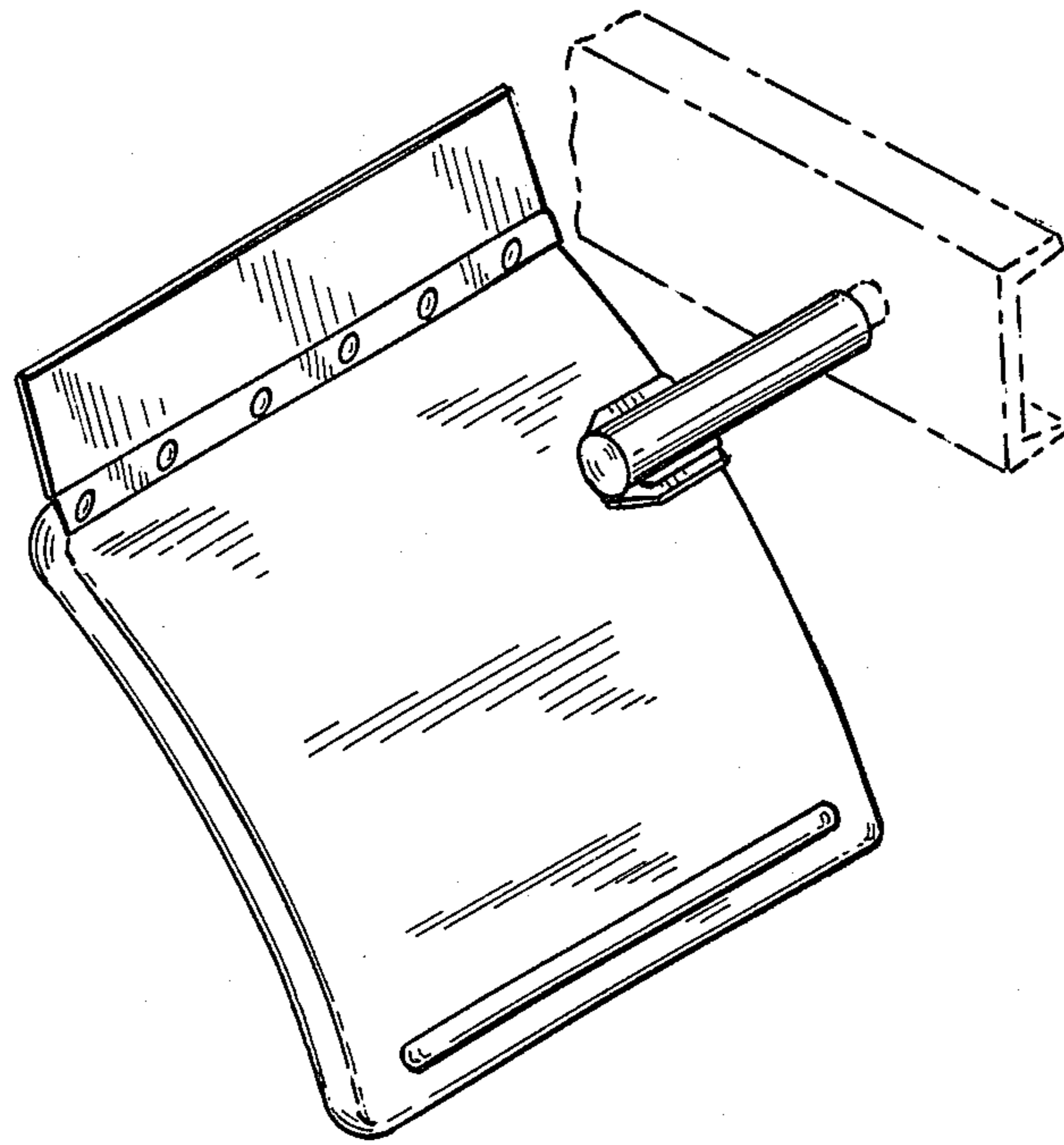

FIG. 1

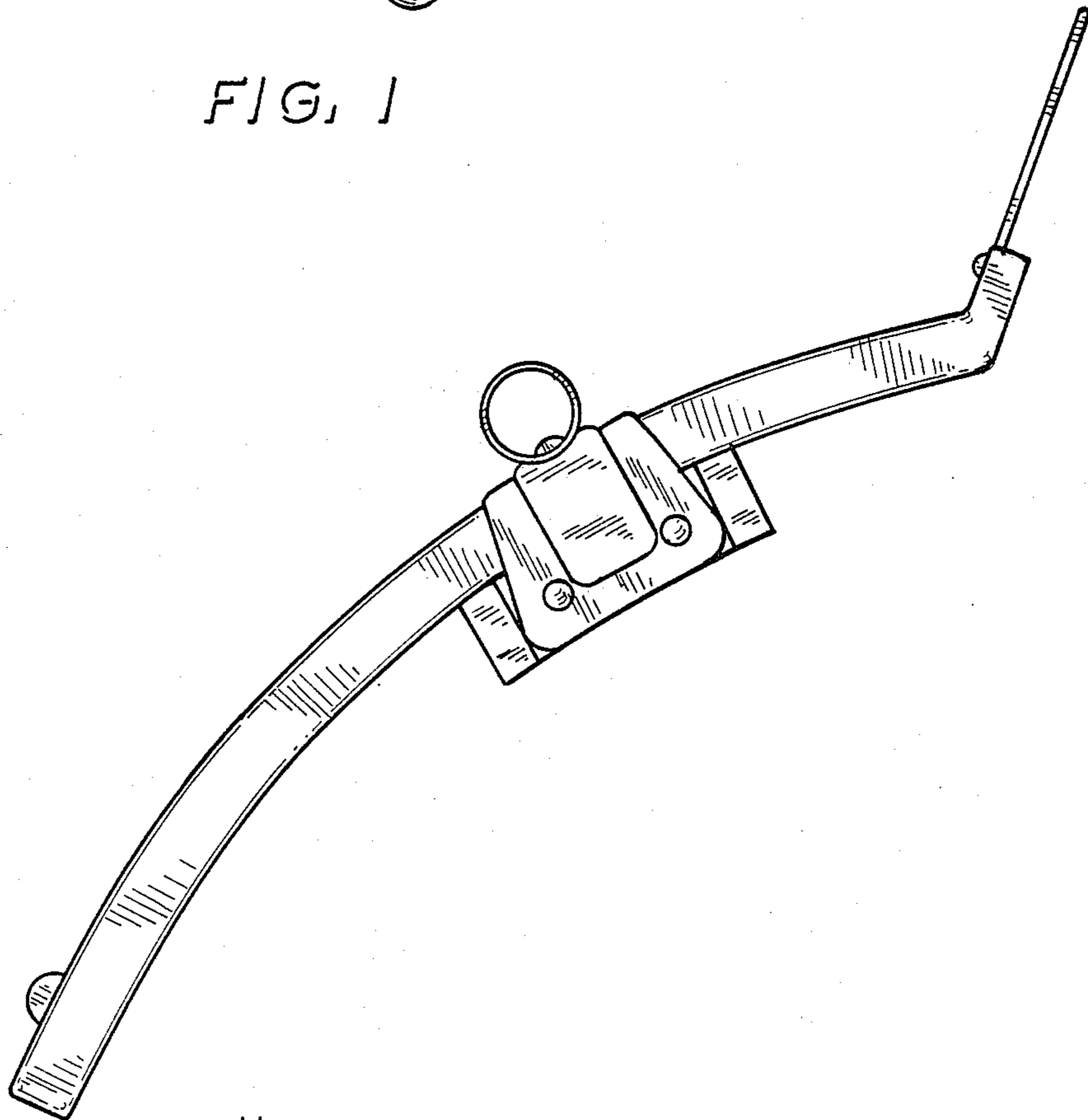

FIG. 2

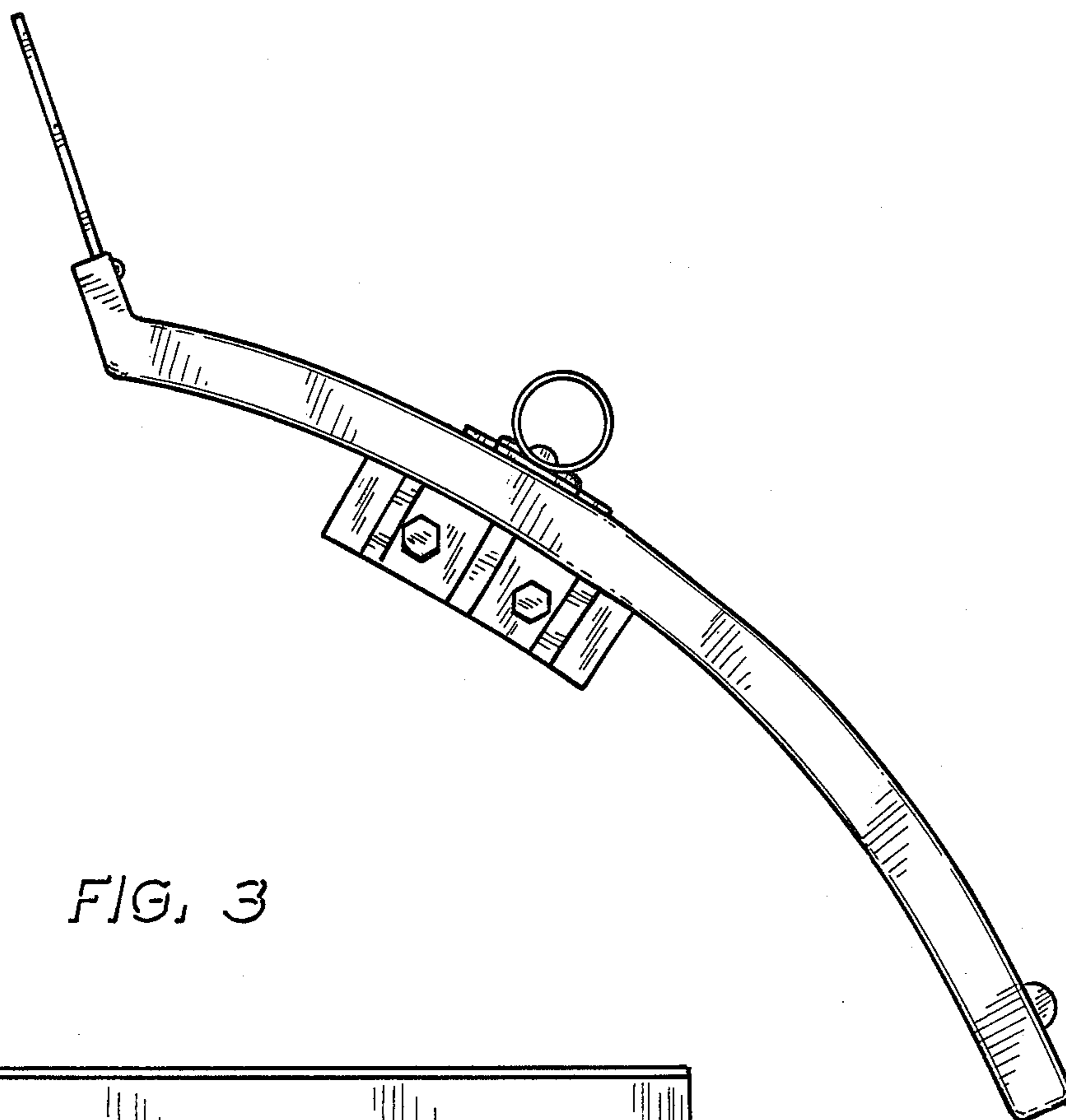

FIG. 3

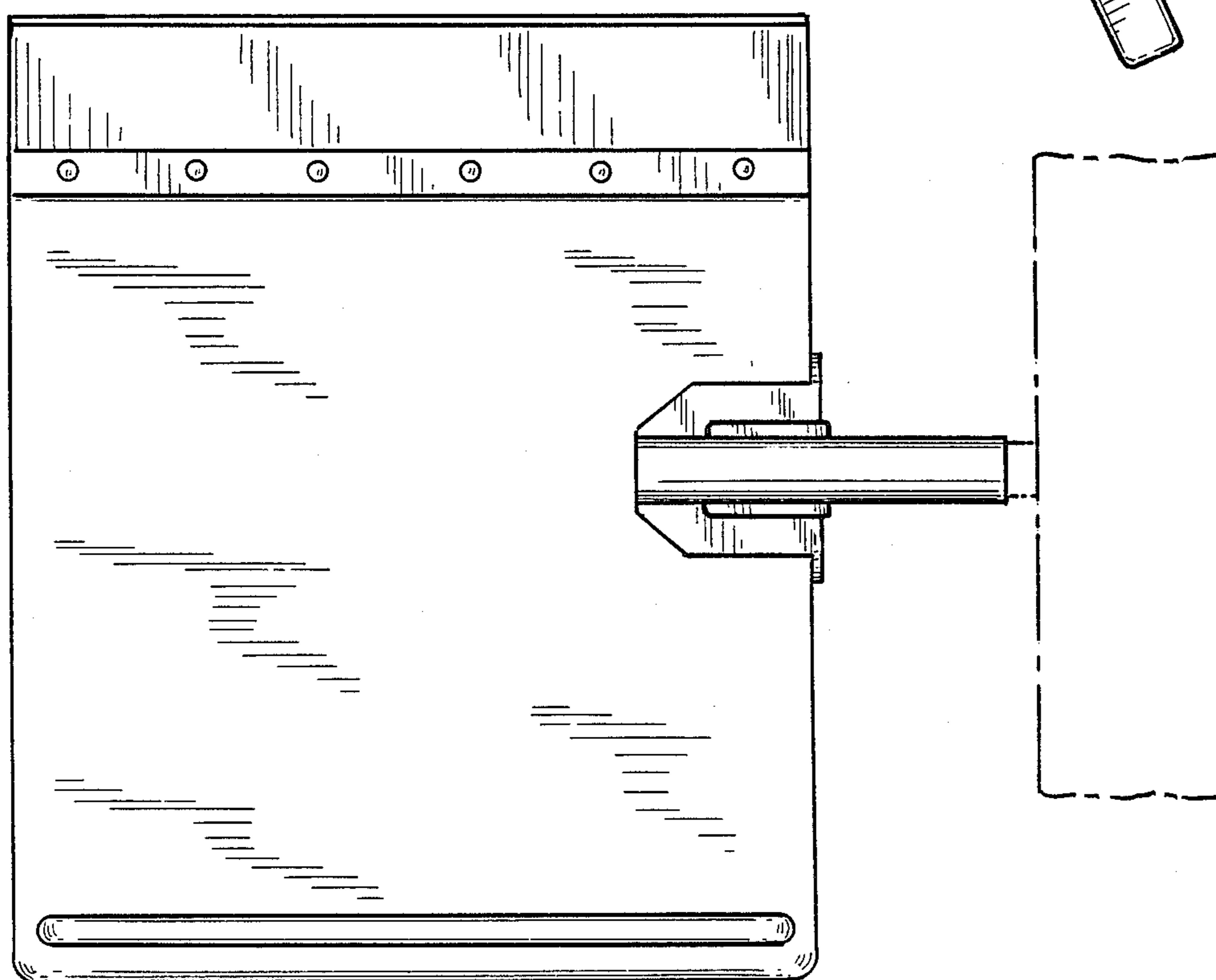

FIG. 4

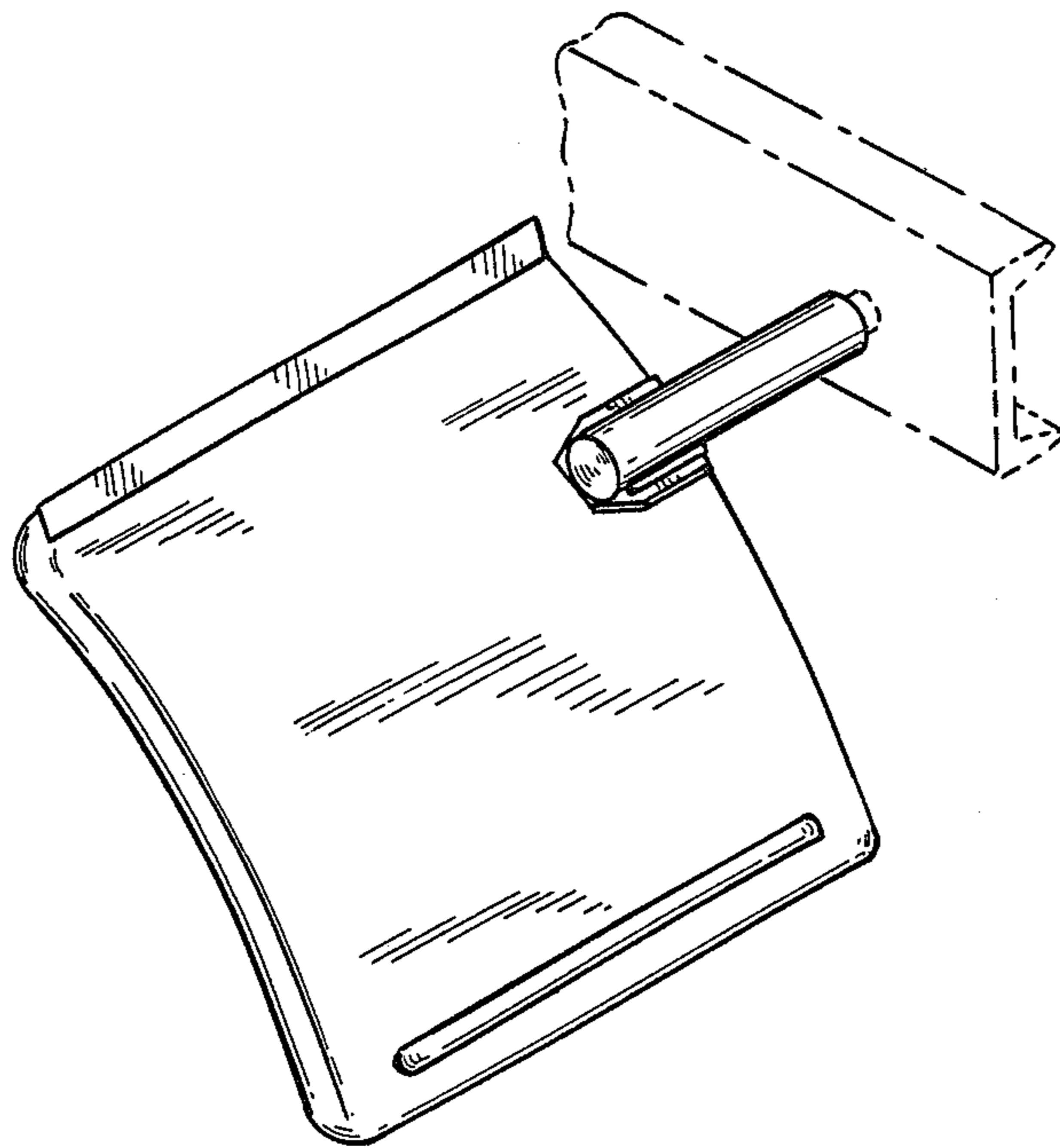

FIG. 6

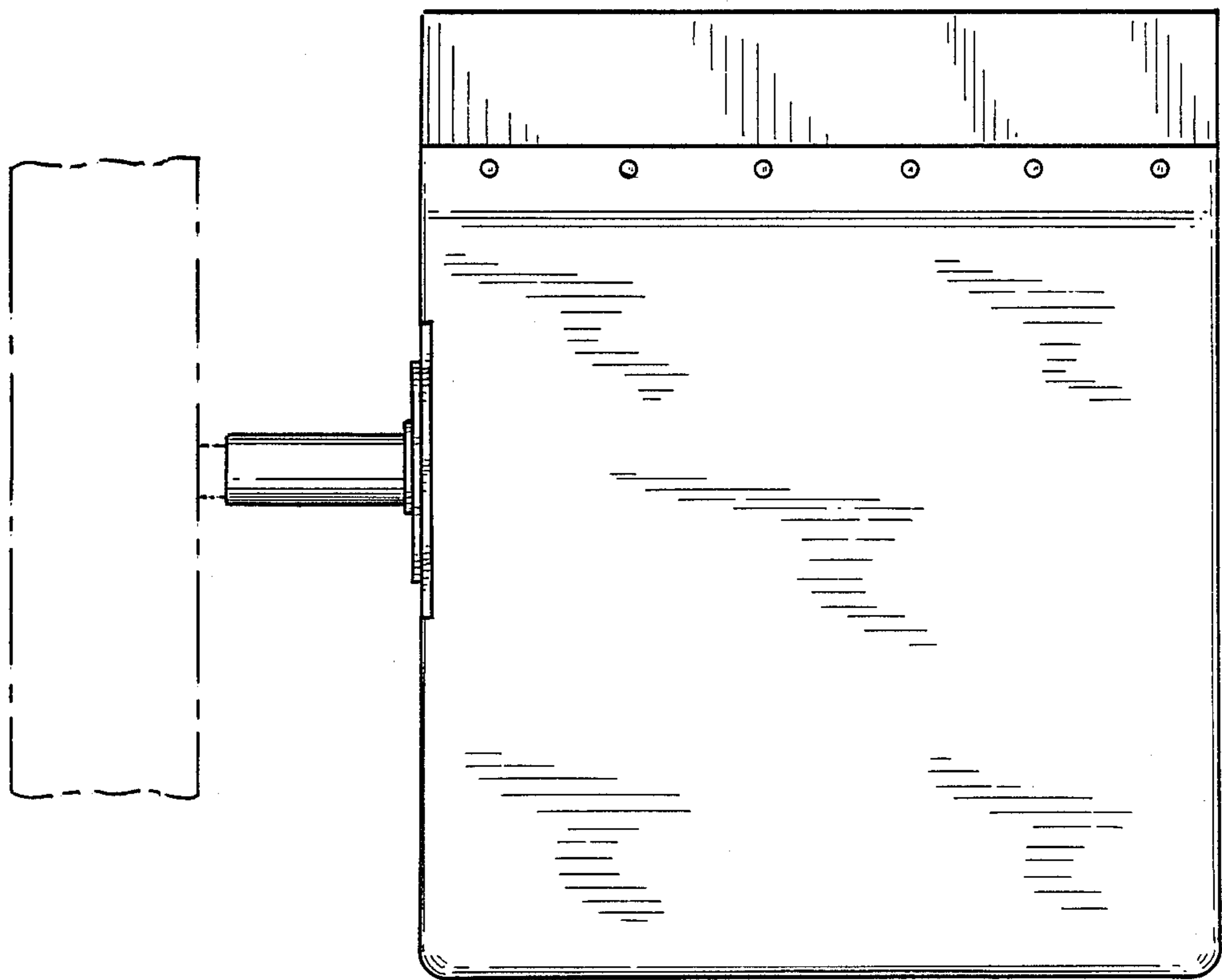

FIG. 5