

[54] AIRCRAFT LANDING WHEEL ROTATOR ATTACHMENT

3,004,738 10/1961 Peterson ..... 244/103 S  
3,178,135 4/1965 Moore ..... 244/103 S

[76] Inventor: Lawrence L. Macaluso, 6632 Baird Ave., Reseda, Calif. 91335

Primary Examiner—Wallace R. Burke  
Assistant Examiner—Kay H. Chin  
Attorney, Agent, or Firm—Cislo & Thomas

[\*\*] Term: 14 Years

[21] Appl. No.: 921,279

[57] CLAIM

[22] Filed: Oct. 21, 1986

The ornamental design for an aircraft landing wheel rotator attachment, as shown and described.

[52] U.S. Cl. .... D12/345

[58] Field of Search ..... D12/345, 319;  
244/103 S

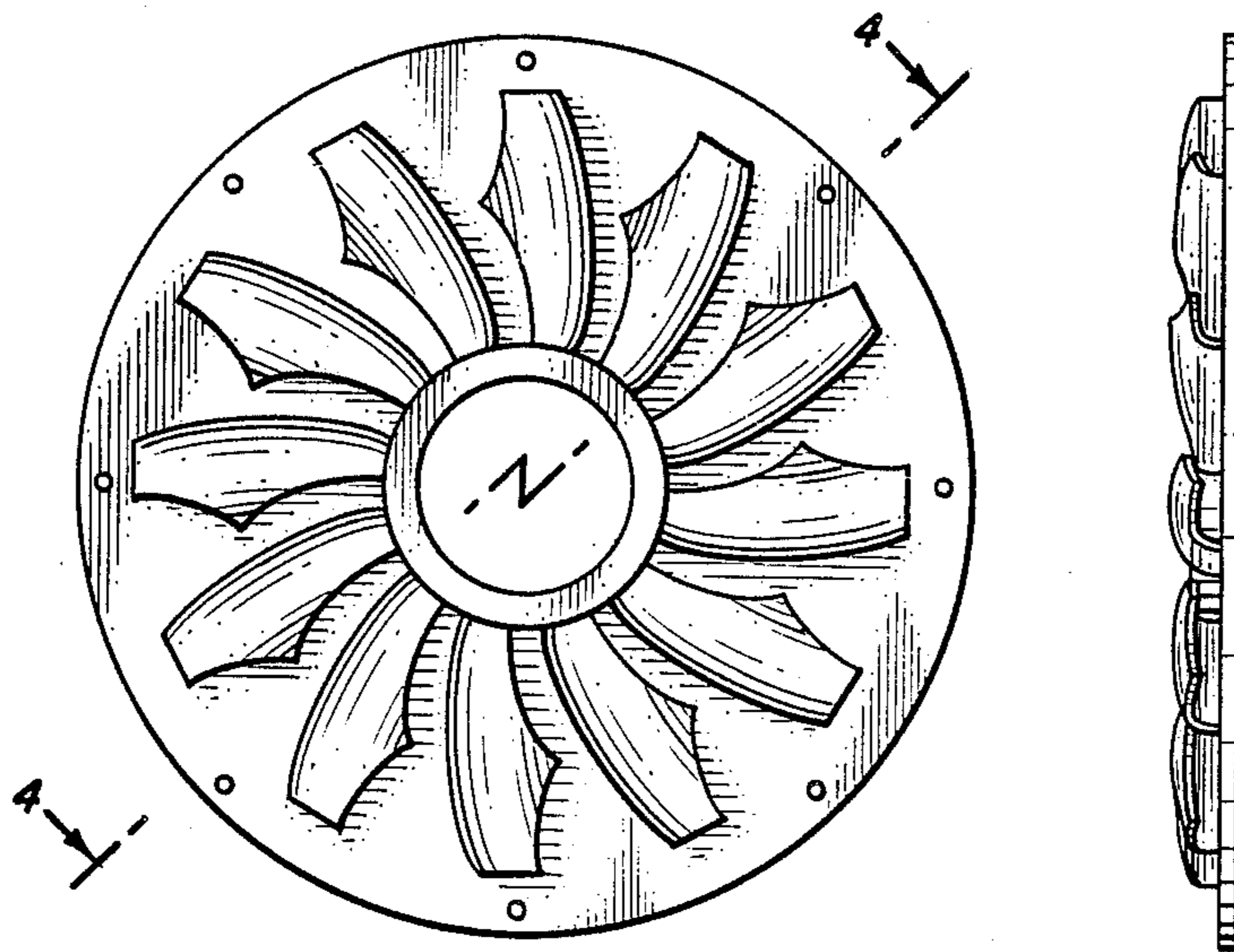
DESCRIPTION

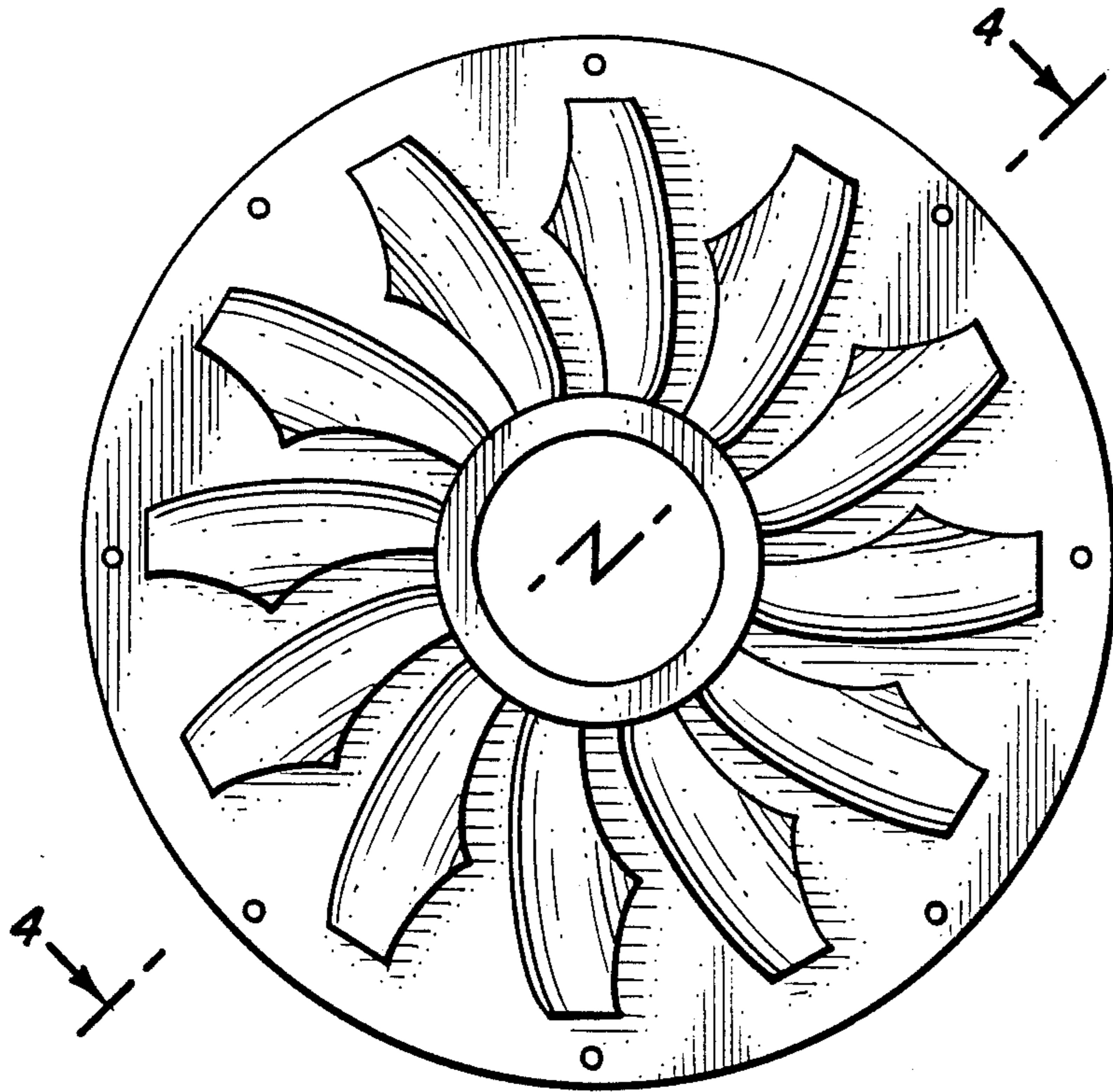
[56] References Cited

U.S. PATENT DOCUMENTS

2,312,159	2/1943	Gulotta	.....	244/103 S
2,410,625	11/1946	Branner	.....	244/103 S
2,464,872	3/1949	Koval	.....	244/103 S
2,777,651	1/1957	Gates	.....	244/103 S

FIG. 1 is a top plan view of an aircraft landing wheel rotator attachment showing my new design;  
FIG. 2 is a right side elevational view thereof, the left side elevational view being a mirror image of that shown;  
FIG. 3 is a bottom plan view thereof; and  
FIG. 4 is a cross sectional view taken along the line 4—4 of FIG. 1.

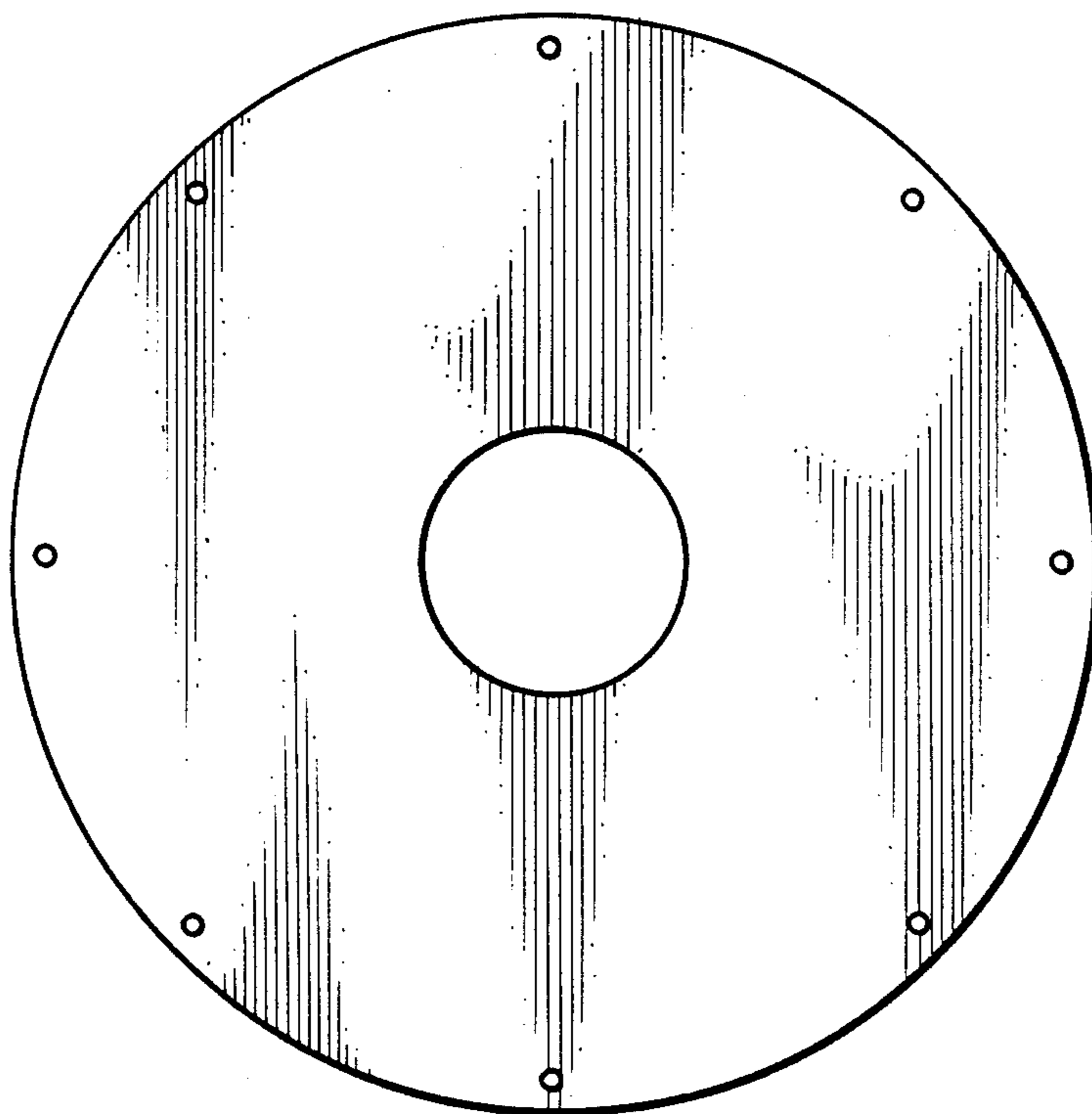




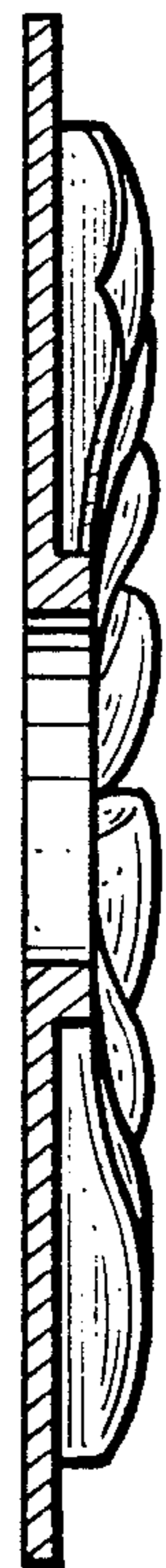
*Fig. 1.*



*Fig. 2.*



*Fig. 3.*



*Fig. 4.*