

[54] ELECTRICALLY POWERED  
THREE-WHEELED VEHICLE FOR THE  
HANDICAPPED AND OTHERS DESIRING  
ASSISTANCE

D. 241,929 10/1976 Cospers ..... D12/131  
D. 285,187 8/1986 Piziks et al. .... D12/131  
D. 285,671 9/1986 Thieme et al. .... D12/85  
4,452,327 6/1984 Mowat et al. .... 180/907

[75] Inventors: Melvin E. Shepard, Bridgeport; Allen  
L. Bussinger, Saginaw, both of Mich.

Primary Examiner—James M. Gandy  
Attorney, Agent, or Firm—Learman & McCulloch

[73] Assignee: Amigo Sales, Inc., Bridgeport, Mich.

[57] CLAIM

[\*\*] Term: 14 Years

The ornamental design for an electrically powered,  
three-wheeled vehicle for the handicapped and others  
desiring assistance, as shown.

[21] Appl. No.: 52,754

DESCRIPTION

[22] Filed: May 21, 1987

[52] U.S. Cl. .... D12/131; D12/85

[58] Field of Search ..... D12/85, 131; 180/215,  
180/216, 211, 907

FIG. 1 is a side elevational view of an electrically pow-  
ered, three-wheeled vehicle for the handicapped, and  
others desiring assistance, showing our new design;  
FIG. 2 is a top plan view;  
FIG. 3 is an bottom plan view;  
FIG. 4 is an opposite side elevational view;  
FIG. 5 is a front elevational view; and  
FIG. 6 is a rear elevational view.

[56] References Cited

U.S. PATENT DOCUMENTS

D. 220,835 6/1971 Thieme ..... D12/85

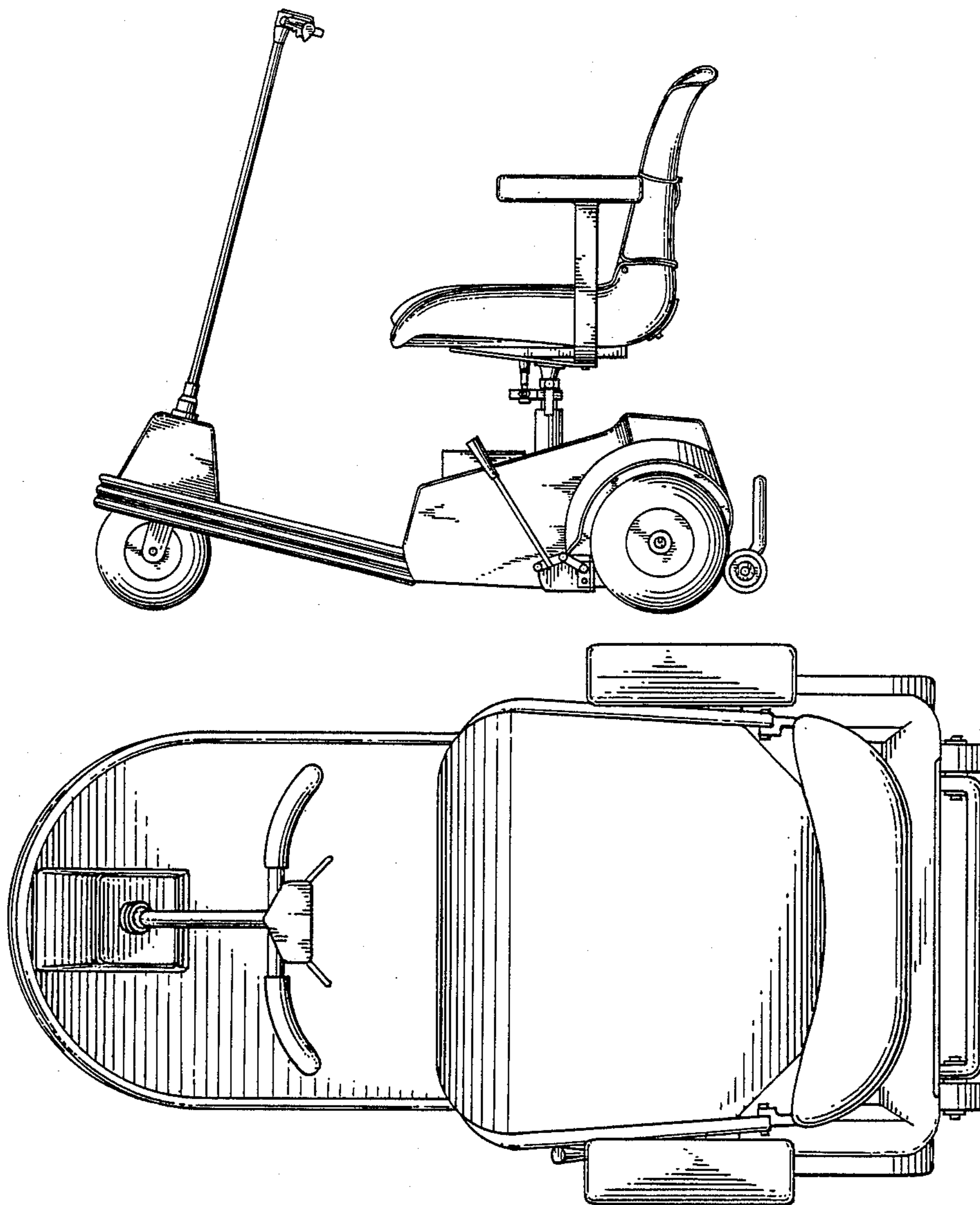

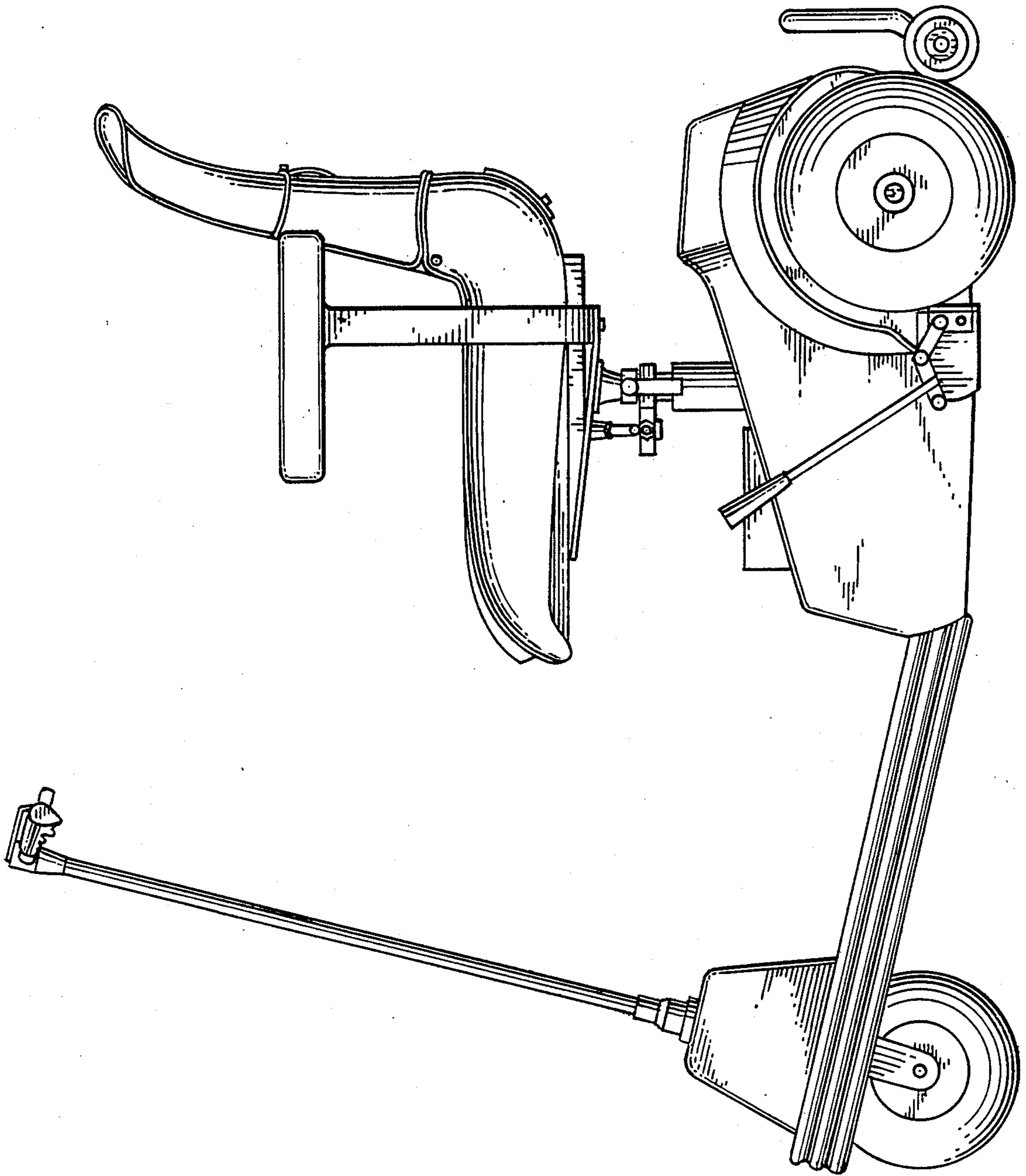

FIG. 1

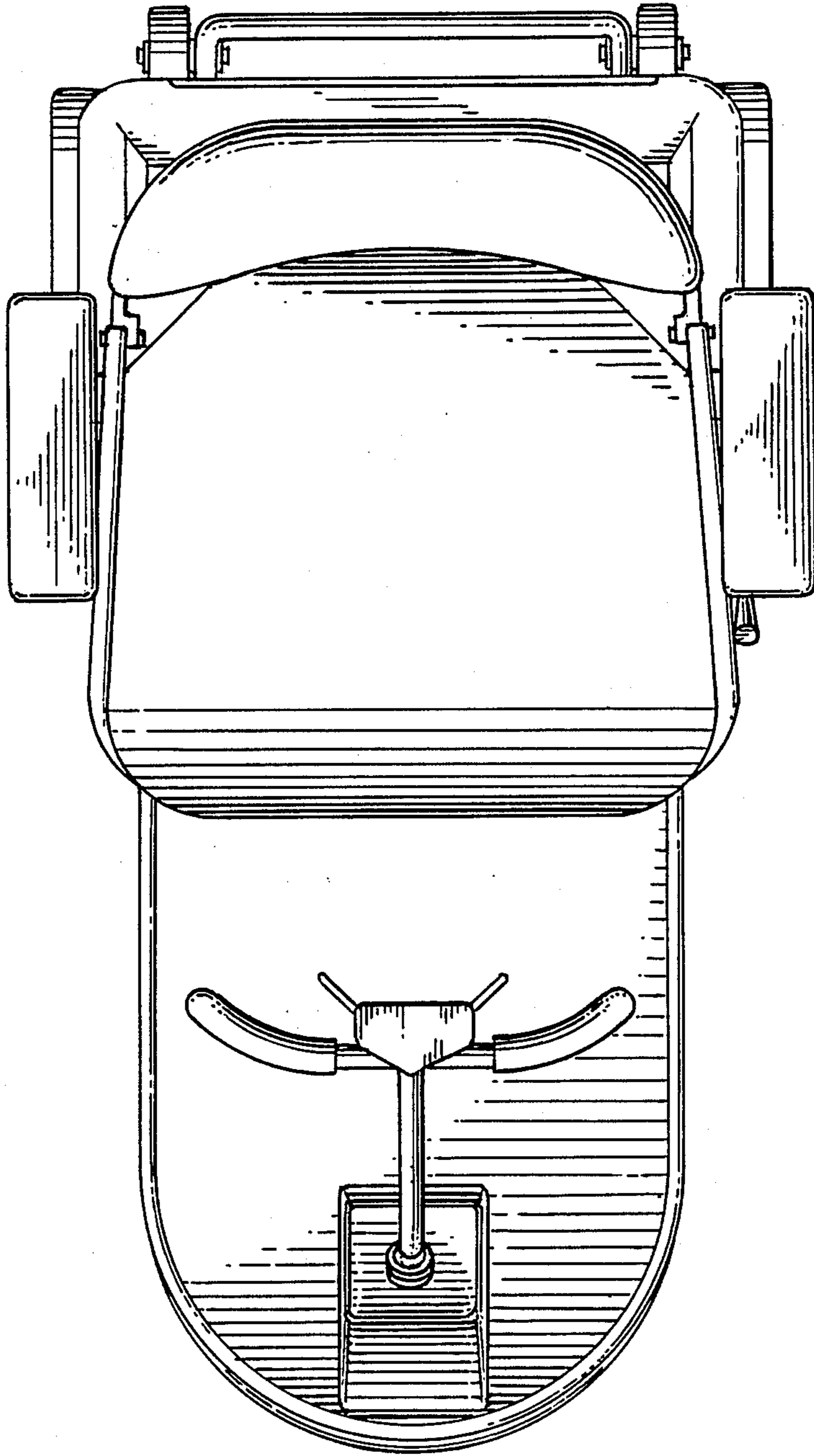

FIG.2

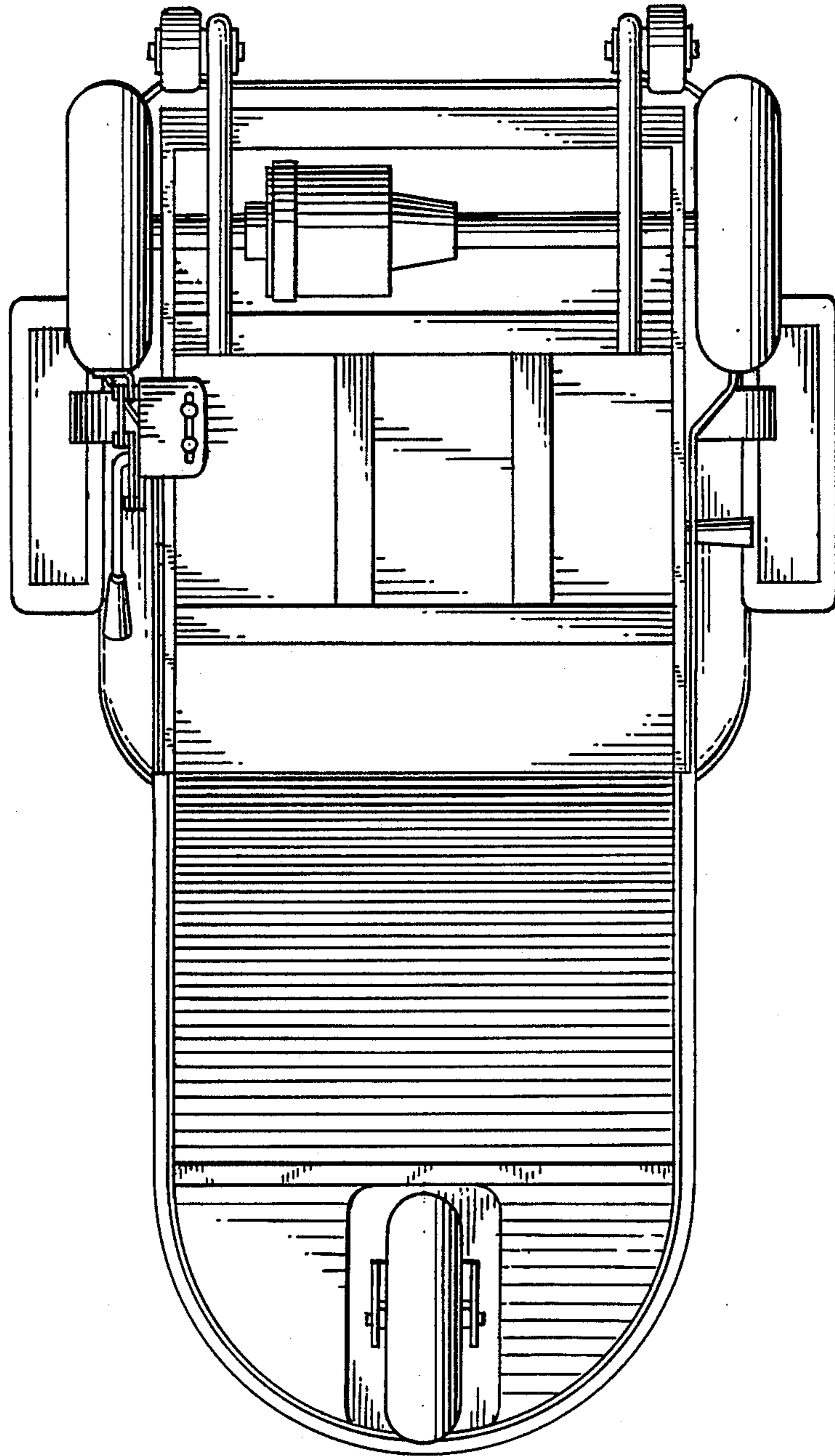

FIG. 3

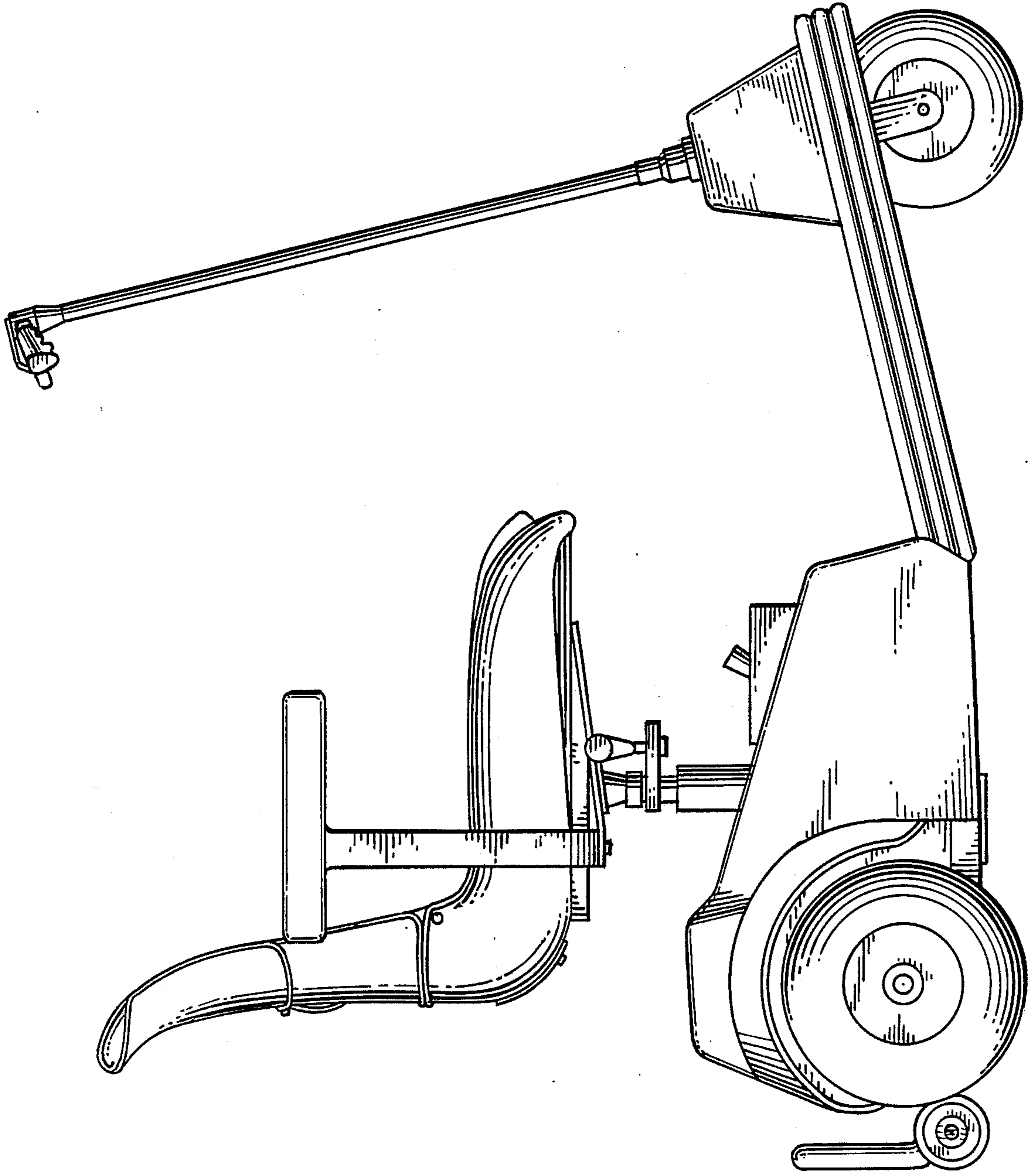

FIG.4

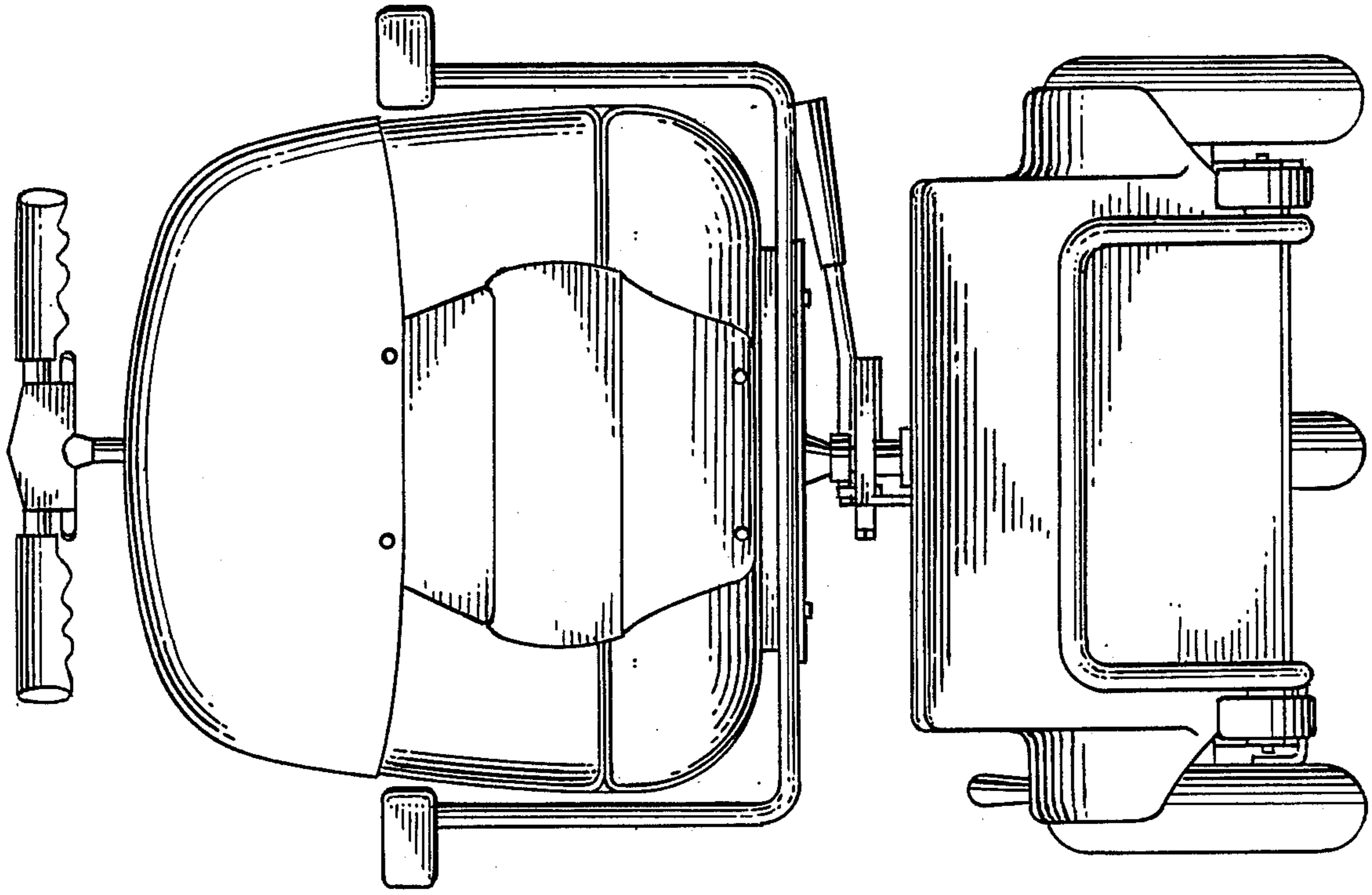

FIG. 6

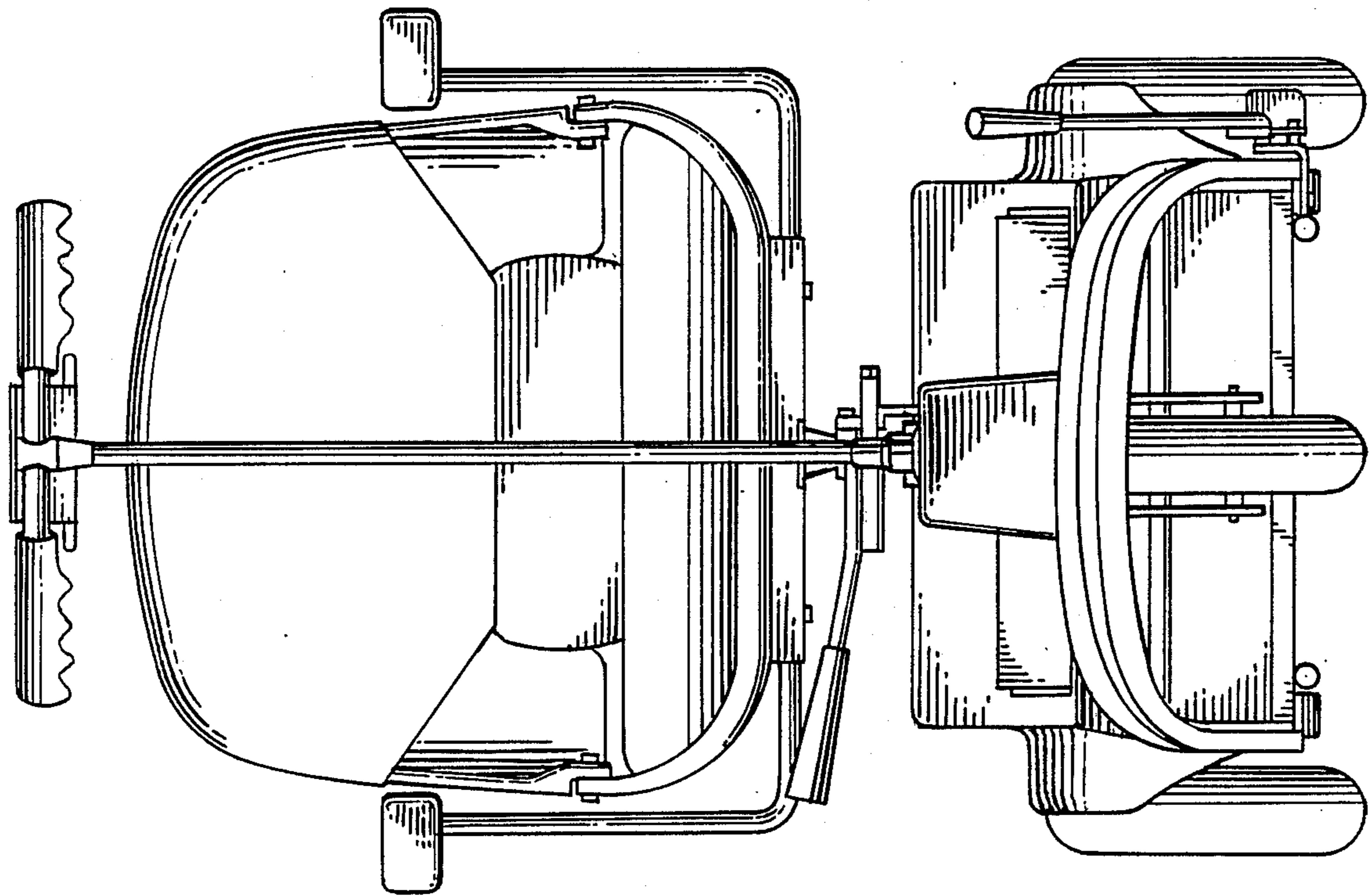

FIG. 5